

May 5, 1931.

L. JONES

1,804,258

MANUSCRIPT HOLDER FOR TYPEWRITERS

Filed April 23, 1930

2 Sheets-Sheet 1

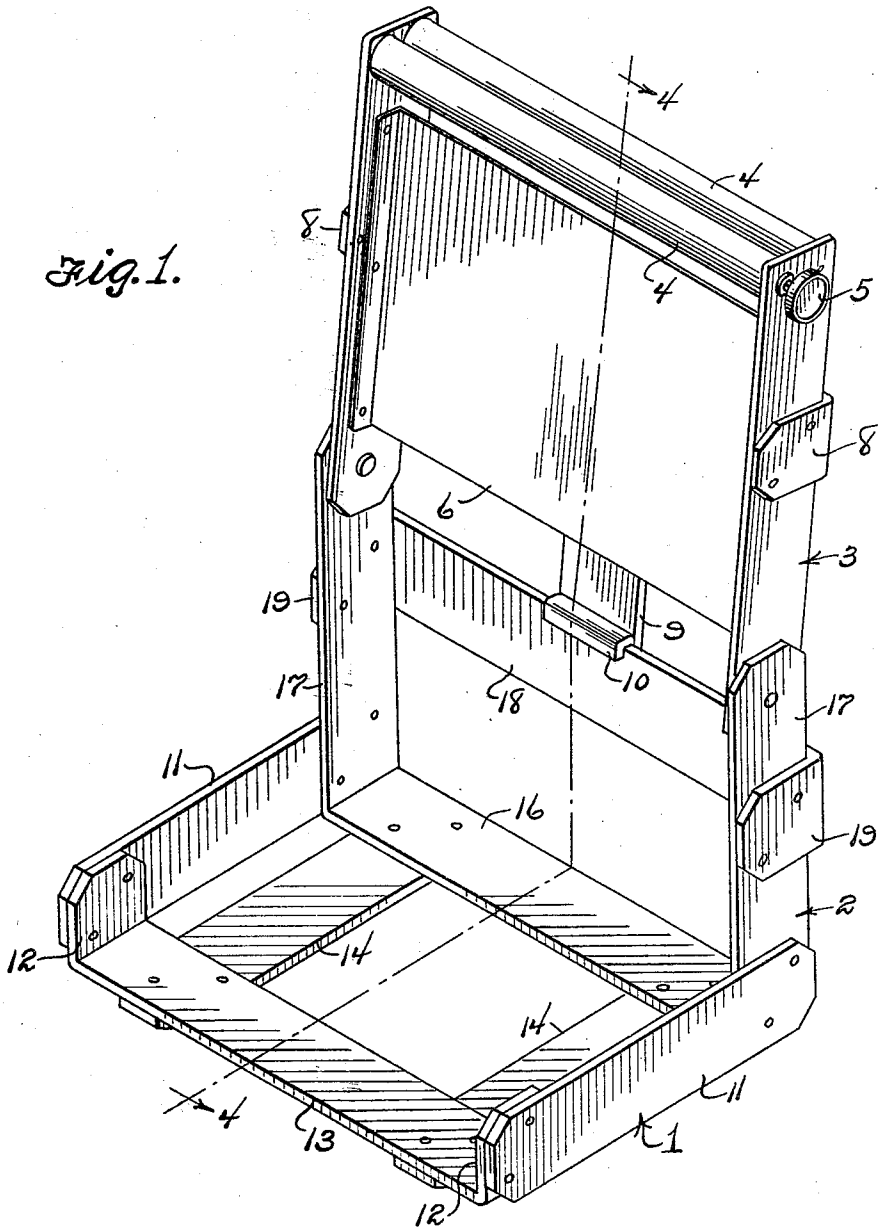

Lawrence Jones
INVENTOR

BY *Victor J. Evans*
ATTORNEY

May 5, 1931.

L. JONES

1,804,258

MANUSCRIPT HOLDER FOR TYPEWRITERS

Filed April 23, 1930

2 Sheets-Sheet 2

Fig. 2.

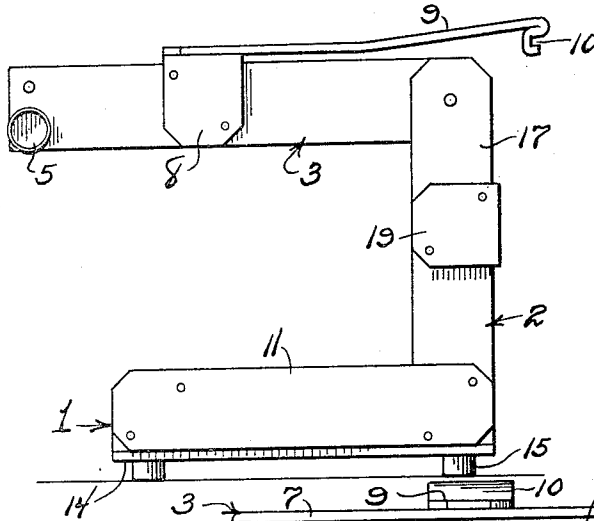

Fig. 3.

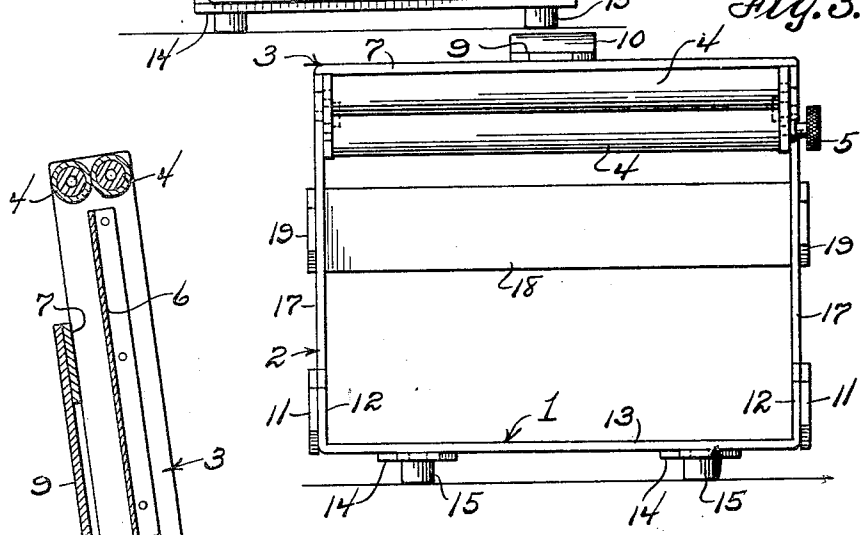
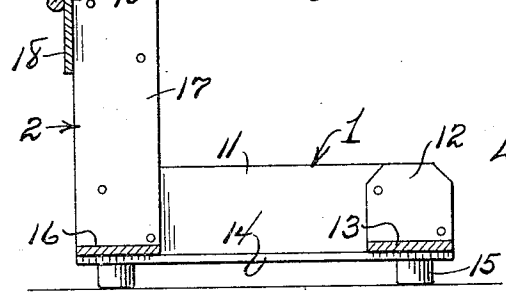

Fig. 4.



Lawrence Jones
INVENTOR
BY Victor J. Evans
ATTORNEY

UNITED STATES PATENT OFFICE

LAWRENCE JONES, OF BEARDS FORK, WEST VIRGINIA

MANUSCRIPT HOLDER FOR TYPEWRITERS

Application filed April 23, 1930. Serial No. 446,729.

This invention relates to new and useful improvements in manuscript or copy holders for typewriters and has for the primary object, the provision of a device of the above stated character which will provide an efficient rest or rack for a typewriter and support the copy of manuscript in clear view of the operator.

Another object of this invention is the provision of means for holding the copy or manuscript and moving the latter at the will of the operator and which means may be folded downwardly and over the typewriter when desiring to cover the typewriter in the customary way.

A further object of this invention is the provision of a manuscript holder for typewriters of the above stated character which will be simple, durable and efficient, and which may be manufactured and sold at a comparatively low cost.

With these and other objects in view as will become more apparent as the description proceeds, the invention consists in certain novel features of construction, combination and arrangement of parts as will be hereinafter more fully described and claimed.

For a complete understanding of my invention, reference is to be had to the following description and accompanying drawings in which:

Figure 1 is a perspective view illustrating a manuscript holder for typewriters constructed in accordance with my invention.

Figure 2 is a side elevation illustrating the same and occupying a folded position.

Figure 3 is a front elevation of the device in the position shown in Figure 2.

Figure 4 is a sectional view taken on the line 4—4 of Figure 1.

Referring in detail to the drawings, the numeral 1 indicates a base having secured to its rear end a vertically disposed support 2 to which is pivotally secured a manuscript or copy holder 3. A typewriter is positioned upon the base 1 with the support 2 located rearwardly of the typewriter, that the copy or manuscript holder 3 will be positioned rearwardly and in a plane above the typewriter and in clear view of the operator. A

pair of feed rollers 4 are journaled to the upper end of the copy holder 3 and have frictional contact with each other and one of said rollers is provided with a finger grip or knob 5 whereby the rollers may be rotated for moving a copy or manuscript upwardly or downwardly according to the will of the operator. The rollers 4 are preferably covered with rubber or other suitable material so that the copy or manuscript may be fed upwardly or downwardly between the rollers by rotating the finger grip or knob 5. The holder 3 includes the side members connected by a backing or plate 6 to support the copy or manuscript in a suspended position from the rollers 4. A brace 7 has its ends 8 angularly related and riveted or otherwise secured to the side members of the holder 3 and a spring catch 9 has the upper end secured to the brace 7 while its free end is bent to form a hook-shaped element 10 adapted to engage the support 2 for holding or retaining the holder 3 in a vertical position and which may be disengaged from the support 2 when desiring to swing the holder 3 horizontally or in a position as shown in Figure 2 over the typewriter thereby permitting the usual cover to be placed over the typewriter and my invention.

The base 1 includes side members 11 riveted or otherwise secured to the angularly related end 12 of a front cross member 13 which has the forward ends of members 14 secured thereto. The members 14 form seats or pad-attaching portions to which the usual pads 15 are secured to prevent the device from marring the support, desk or the like on which the device and typewriter may be positioned. A substantially U-shaped member 16 has the web portions thereof secured to the rear ends of the members 14 and the arm portions 17 disposed vertically and secured to the rear ends of the side members 11. A brace 18 has angularly related ends 19 that are riveted or otherwise secured to the arm portions 17 adjacent their upper ends and the brace 18 is engaged by the spring catch 9 as shown in Figure 1 when the holder 3 is in an operative position. The side members of the holder 3 are pivoted to the free ends of the arm portions of the

substantially U-shaped member as clearly shown in the drawings.

In operation, a typewriter is positioned on the base 1 with the vertical support located in rear of the typewriter. With the holder 3 disposed vertically as shown in Figures 1 and 4, the operator will have the manuscript or copy disposed in front and in alignment with the eyes so that the subject matter of the copy or manuscript may be easily read. When discontinuing the use of the typewriter, the holder 3 may be swung downwardly and over the typewriter into the position shown in Figure 2 whereby the usual typewriter cover may be placed over the entire device including the typewriter.

While I have shown and described the preferred embodiment of my invention, it will be understood that minor changes in construction, combination and arrangement of parts may be made without departing from the spirit and scope of the invention as claimed.

Having thus described the invention, what I claim is:

A device of the character set forth comprising a base, cushion feet carried by said base, a vertical support secured to said base, a brace carried by said support, a manuscript holder pivoted to said support, a resilient member secured to said holder and having its free end bent to form a hook-shaped portion adapted to engage the brace for supporting the holder in a vertical position and to permit the holder to be swung into a horizontal position.

In testimony whereof I affix my signature.

LAWRENCE JONES.

40

45

50

55

60

65