

(19)
(12)

(KR)
(B1)

(51) 。 Int. Cl.7
A47B 47/00

(45)
(11)
(24)

2005 01 13
10-0466260
2005 01 04

(21) 10-2001-0054386
(22) 2001 09 05

(65)
(43)

10-2003-0021331
2003 03 15

(73) 3가 55-1 101 110

(72) 3가 55-1 101 110

(74)

:

(54) 가

가 , 가

; , ; ;

; , ; , 가 .

1

, , 가

1

가 .

; , ;
 ; , ;
 ; , ;
 , 가 가 .
 2.
 3.
 4.
 1 , 가 가 .
 5.

1

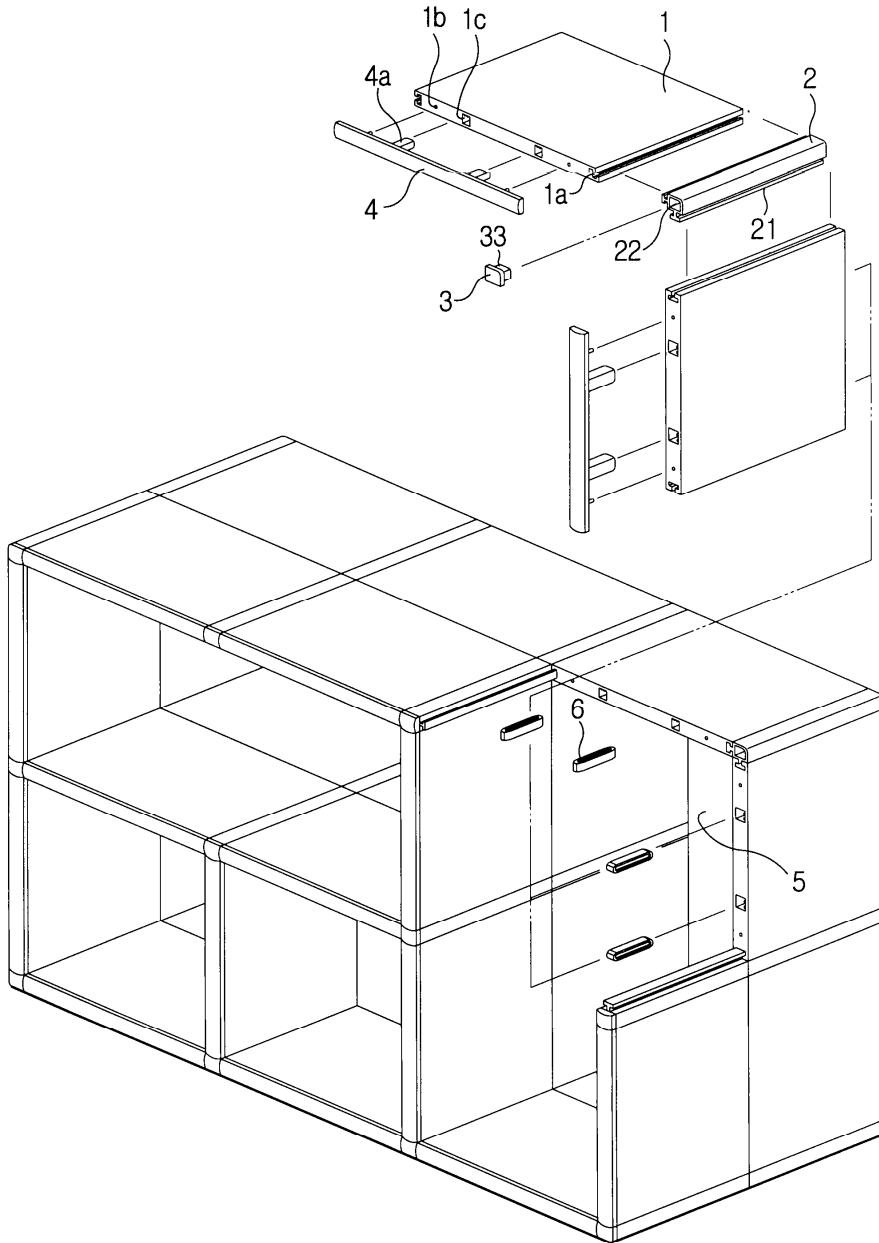

2

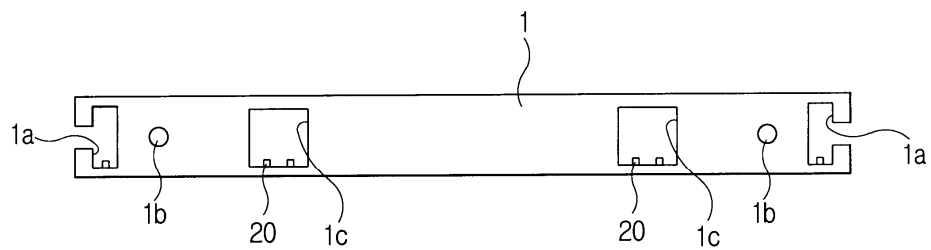

3a

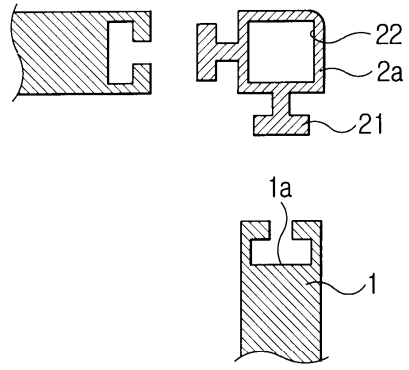

3b

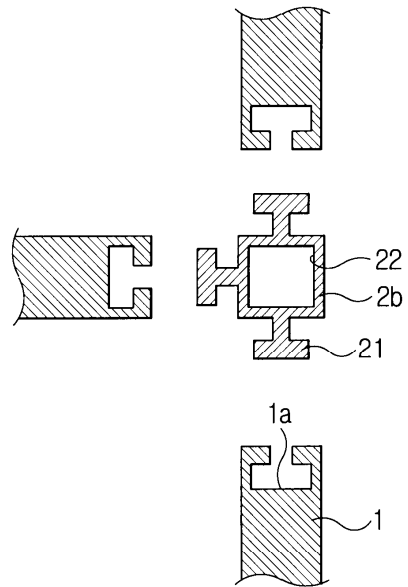

3c

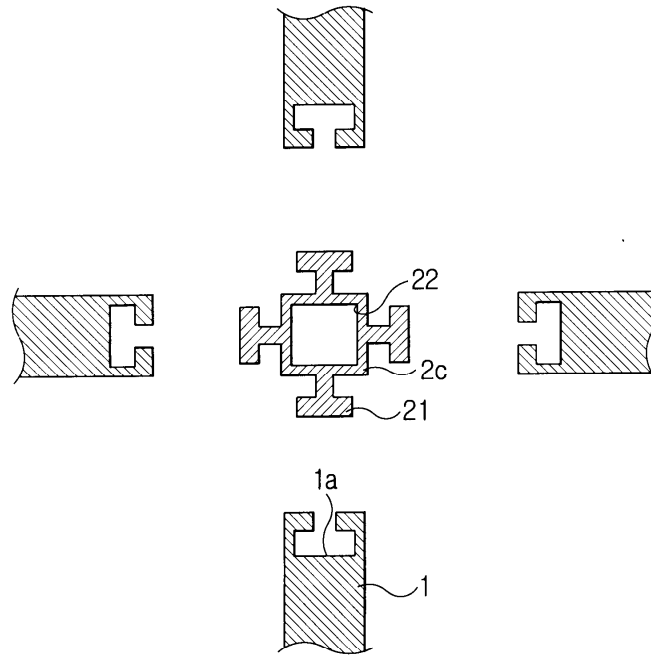

3d

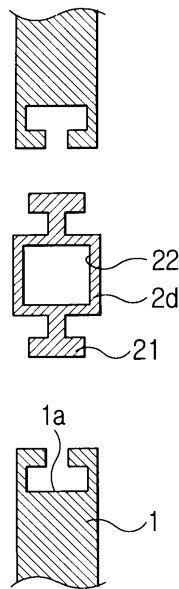

3e

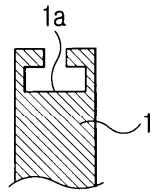
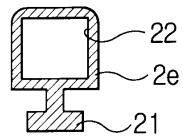

4a

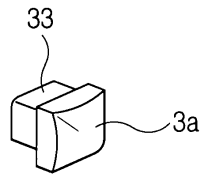

4b

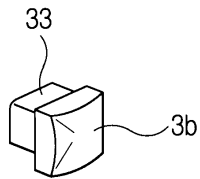

4c

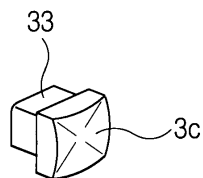

4d

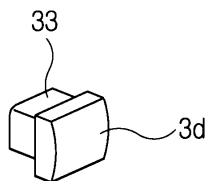

4e

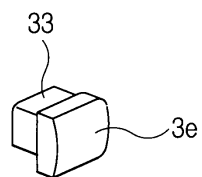

5a

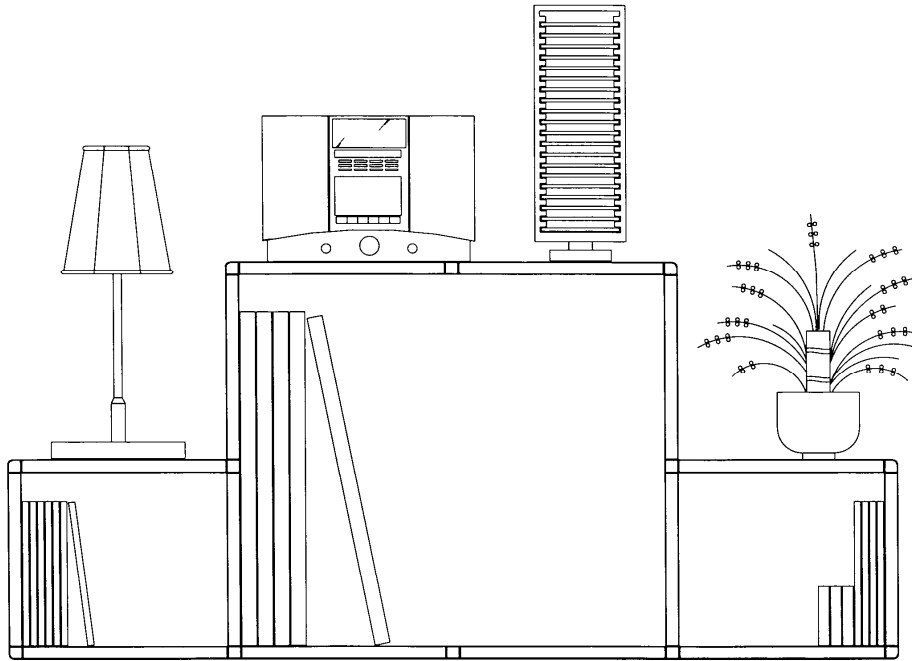

5b

