

(19) World Intellectual Property  
Organization  
International Bureau



(43) International Publication Date  
24 November 2005 (24.11.2005)

PCT

(10) International Publication Number  
**WO 2005/110142 A1**

- (51) International Patent Classification<sup>7</sup>: **A44B 18/00**
- (21) International Application Number:  
PCT/US2005/005674
- (22) International Filing Date: 23 February 2005 (23.02.2005)
- (25) Filing Language: English
- (26) Publication Language: English
- (30) Priority Data:  
10/837,346 30 April 2004 (30.04.2004) US
- (74) Agents: **CHARLIER, Patricia, A.** et al.; **KIMBERLY-CLARK WORLDWIDE, INC.**, 401 N. Lake Street, Neenah, WI 54956 (US).
- (81) Designated States (unless otherwise indicated, for every kind of national protection available): AE, AG, AL, AM, AT, AU, AZ, BA, BB, BG, BR, BW, BY, BZ, CA, CH, CN, CO, CR, CU, CZ, DE, DK, DM, DZ, EC, EE, EG, ES, FI, GB, GD, GE, GH, GM, HR, HU, ID, IL, IN, IS, JP, KE, KG, KP, KR, KZ, LC, LK, LR, LS, LT, LU, LV, MA, MD, MG, MK, MN, MW, MX, MZ, NA, NI, NO, NZ, OM, PG, PH, PL, PT, RO, RU, SC, SD, SE, SG, SK, SL, SM, SY, TJ, TM, TN, TR, TT, TZ, UA, UG, US, UZ, VC, VN, YU, ZA, ZM, ZW.

- (71) Applicant (for all designated States except US): **KIMBERLY-CLARK WORLDWIDE, INC.** [US/US]; 401 N. Lake Street, Neenah, WI 54956 (US).
- (72) Inventors; and
- (75) Inventors/Applicants (for US only): **EFREMOVA, Nadezhda** [RU/US]; 897 Mill Pond Lane, Neenah, WI 54956 (US). **PIERCE, Joseph, Earl** [US/US]; 268 River Drive, Appleton, WI 54915 (US). **YU, Lisha** [CN/US]; 1325 E. Overland Road, Appleton, WI 54911 (US). **VANBENSCHOTEN, Brian** [US/US]; 10 Railroad Street, Newmarket, NH 03857 (US). **KURTZ, Wallace, L., Jr.** [US/US]; 164 Leominster Road, Lunenburg, MA 01462 (US). **TACHAUER, Ernesto, S.** [CA/US]; 62 Grafton Drive, Bedford, NH 03110 (US).
- (84) Designated States (unless otherwise indicated, for every kind of regional protection available): ARIPO (BW, GH, GM, KE, LS, MW, MZ, NA, SD, SL, SZ, TZ, UG, ZM, ZW), Eurasian (AM, AZ, BY, KG, KZ, MD, RU, TJ, TM), European (AT, BE, BG, CH, CY, CZ, DE, DK, EE, ES, FI, FR, GB, GR, HU, IE, IS, IT, LT, LU, MC, NL, PL, PT, RO, SE, SI, SK, TR), OAPI (BF, BJ, CF, CG, CI, CM, GA, GN, GQ, GW, ML, MR, NE, SN, TD, TG).
- Published:  
— with international search report
- For two-letter codes and other abbreviations, refer to the "Guidance Notes on Codes and Abbreviations" appearing at the beginning of each regular issue of the PCT Gazette.

(54) Title: REFASTENABLE GARMENT ATTACHMENT MEANS WITH LOW IMPACT ON THE GARMENT

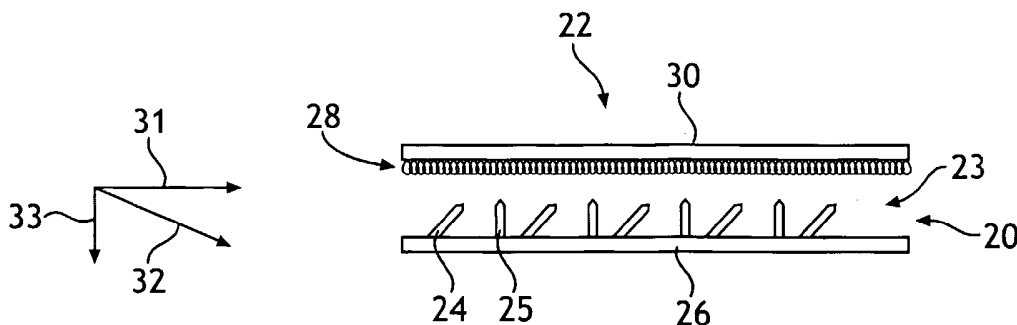

(57) Abstract: A male component of a mechanical fastening system, such as a hook and loop fastener, that can remain fastened to a female component under high levels of shear force. The male component has a backing material with protrusions extending from the backing material at an angle toward the direction of fastener force. The combination of the male component with a female loop component results in a secure fastening system.

WO 2005/110142 A1

## REFASTENABLE GARMENT ATTACHMENT MEANS WITH LOW IMPACT ON THE GARMENT

### Background Of The Invention

The use of fastening systems on disposable absorbent products, such as diapers, training pants, adult incontinent products, feminine care products, and the like, is well known. These fastening systems include pins, ties, buttons, snaps, adhesives, and mechanical fastening systems. Key performance requirements of such fastening systems include a balance of maintaining the position of the absorbent products during use and low/no impact on the garments that the fastening system comes into contact with or utilizes during the use of the absorbent product.

Refastenable mechanical fastening systems such as Velcro®-style hook and loop mechanical fastening systems are well known in the art. Typically, such fastening systems involve two major components, a male component and a female component that when engaged can hold two substrates together. The male component typically includes a backing material with a number of protruding hook elements that are designed to engage with a number of loops on a complimentary female component. These hook elements protruding from the backing material of the male component typically consist of a base, a shank and an engaging means in the form of a hook, a cap, a spherical/hemispherical shape, a flat top, etc. Generally, a loop fastening material comprises fibrous loops protruding from the backing material and is capable of engaging the above-described male component of a mechanical fastener.

When the mechanical fastening system becomes engaged, a hook element penetrates the loop fastening material and either engages or intercepts fibrous loops of the loop fastening material. This results in a mechanical interference and physical obstruction which prevent the removal of hook material from the loop material until the separation forces, usually in the form of either peel or shear forces, exceed a certain threshold. After this, the disengagement of a mechanical fastener occurs resulting in separation of the hook component and the loop component. Furthermore, the separation forces being applied to the loop material during the disengagement stage can result in loop breakage, fiber pull-out and fiber string-out, fuzzy marks on the loop material etc., up to mechanical tear of the loop material.

The common way to avoid these problems is to use a female component of a mechanical fastening system that is specifically designed to engage with a particular male component and thus possesses a necessary mechanical strength, fiber strength, fiber thickness, and/or a particular fiber bonding pattern, in order to prevent the above-mentioned problems. Examples of suitable loop materials include Velcro® brand loop materials sold by Velcro USA of Manchester, N.H., stitchbonded fabric sold by the Milliken & Company of Spartanburg, S.C., or a loop material available from Guilford Mills, Inc., Greensboro, N.C. under the trade designation No. 36549. Another suitable loop material can comprise a pattern un-bonded web as disclosed in U.S. Patent No. 5,858,515 issued on January 12, 1999 to Stokes et. al. The fact that the dual surface (i.e., two separate surfaces) is required to enable hook and loop style mechanical fastener makes it a costly material, decreases flexibility of mechanical fastening system, and therefore creates limitations for its use.

Mechanical fastening systems have been devised which provide for repeated refastening as well as being lightweight and secure. Hook and loop type mechanical fastening systems, such as Velcro-style fasteners, are well known in the art. Such fastening systems involve two major components, a male component and a female component. The male component typically includes a backing material with a number of protruding hooks that are designed to engage with a number of loops on a complimentary female component. The hooks protruding from the backing material of the male component typically project perpendicularly to the direction of fastener shear force. The hooks typically have a base, a shank, and an engaging means in the form of a hook, cap, or spherical or hemi-spherical shape. Generally, loop fastening materials will comprise loops, fibers, or the like with the engaging elements of the hook fastening material can become entangled.

When the mechanical fastening system is fastened and shear force acts upon the fastening system, the hooks pull toward the direction of fastener force. As the hooks are pulled which can result in the hooks releasing the loops, the mechanical fastening system may become unfastened as a final result. Furthermore, the fastener force applied to the loops during disengagement may result in damage to the loops, such as loop breakage, fiber pull-out and string-out. Furthermore, the male component often produce red-marking and irritation if brought into contact with a person's skin, such as an infant's skin in contact with a male component of a diaper mechanical fastening system.

There is a need or desire for a male component of a mechanical fastening system that is capable of remaining fastened to a female component under effective levels of shear force while not damaging or distorting the female component.

5

There is a need or desire for a more universal male component of a mechanical fastening system that is capable of engaging into a wide variety of different potential female components, such as fabrics used in garment manufacturing, e.g. knitted fabrics, woven fabrics, non-woven fabrics, and the like. There also is a need or desire for a male component of a mechanical fastening system that is capable of remaining fastened to an above-specified group of female components under in-use levels of shear force while not damaging or distorting the female component. There is also a need or desire for a male component that is capable to release or disengage from the female component under the effective levels of peel force during disengagement while not damaging or distorting the female component. There is also a need or desire for a male component that can be securely re-attached to the female component after disengagement.

There is also a need or desire for a male component of a mechanical fastening system that reduces or eliminates the occurrence of red-marking and/or irritation if brought into contact with a person's skin.

20

### Summary Of The Invention

The present invention is directed to a male component of a mechanical fastening system such as hook and loop fastener, comprising protrusions wherein at least a portion of the protrusions may be angled toward the direction of fastener shear force acting on the mechanical fastening system in use. The angled protrusions may withstand a higher shear force than conventional perpendicular hooks on the male component without becoming disengaged from the female component, such as loop material, resulting in an advantageously more secure mechanical fastening system. The angled protrusions of the male component may be disengaged from the female component of the mechanical fastening system without causing damage to the above-mentioned female component. The angled protrusions on the male component may reduce skin irritation often caused by perpendicular hooks.

10

The angled protrusions are non-hook type angled protrusions located on the male component. In some embodiments of the present invention, the entire surface of the male component may be covered with angled protrusions, the surface of the male component may have a combination of perpendicular protrusions and angled protrusions, or the surface of the male component may have a combination of zones covered with angled/perpendicular protrusions and zones with no protrusions. The protrusions, angled and/or perpendicular, on the male component may have similar or different heights.

The angled protrusions may be formed from a mold designed to produce such protrusions, or from a mold specially shaped to produce angled protrusions when the male component is removed from the mold. In some situations, the protrusions may be formed from a mold designed to produce perpendicular protrusions, and then angled in the after-treatment. Alternatively, the angled protrusions may be formed by using two or more polymers side-by-side in a mold, such that the protrusions become angled as the polymers cool due to differential shrinkage of the polymers.

With the foregoing in mind, it is a feature and advantage of the present invention to provide a male component of a mechanical fastening system that may remain fastened to a female component under the in-use levels of shear force without causing noticeable damage or distortion of the female component.

It is another feature and advantage of the present invention to provide a male component of a mechanical fastening system that may be released or disengaged from the female component under effective levels of peel force without causing noticeable damage or distortion of the female component.

It is another feature and advantage of the present invention to provide a male component of a mechanical fastening system that may engage a variety of different materials serving as female components, such as knitted, non-woven, and woven materials.

It is yet another feature and advantage of the present invention to produce a mechanical fastening system that includes the above male component.

It is another feature and advantage of the present invention to provide a male component of a mechanical fastening system that reduces or eliminates the occurrence of red-marking and/or irritation if brought into contact with a person's skin.

5

Brief Description Of The Drawings

**Figure 1** is a side view of a male component and a female component of a mechanical fastening system of the present invention prior to engagement with one another;

10

**Figure 2** is a side view of a male component of a mechanical fastening system of the present invention shown in partial engagement with a female component;

15

**Figure 2a** is a side view of a male component of a mechanical fastening systems of the present invention shown in partial disengagement from a female component by the application of a peel force.

**Figure 3** is a perspective view of a male component of a mechanical fastening system of the present invention;

20

**Figure 4** is a side view of an angled protrusion on a male component of a mechanical fastening system of the present invention;

25

**Figure 5** is a side view of an angled protrusion on a male component of a mechanical fastening system of the present invention engaged with a female component;

**Figure 6a-b** is a side view of an angled protrusion on a male component of a mechanical fastening system of the present invention;

30

**Figures 7a – 7d** are side views of angled protrusions on male components of mechanical fastening systems of the present invention;

**Figures 8 a – 8g** are cross-sectional views of protrusions of mechanical fastening systems of the present invention;

35

**Figure 9** is a plan view of a garment-facing side of a disposable absorbent article incorporating a male component of a mechanical fastening system of the present invention;

**Figure 10** is a side view of an angled protrusion comprised of two different materials on a male component of a mechanical fastening system of the present invention.

**Figure 11** is a plan view of a garment-facing side of an absorbent article consisting of multiple groups of protrusions.

**Figures 12a - 12d** are microphotographs of some loop materials at a magnification of 50x.

**Figure 13a** is a microphotograph of loop material before the engagement of a conventional hook material.

15

**Figure 13b** is a microphotograph of loop material after the engagement of a conventional hook material and subsequent disengagement of the conventional hook material.

**Figures 14a - 14b** are top plan views of portions of a male component of mechanical fastener with angled protrusions.

20

**Figures 14c - 14d** are side views of portions of a male component of mechanical fastener with angled protrusions.

25

**Figures 15a - 15c** are bar graphs showing of pore size distributions of loop materials.

**Figures 16a - 16d** are schematic drawings of void patterns of loop materials.

30

#### Definitions

Within the context of this specification, each term or phrase below will include the following meaning or meanings.

35

"Angled Protrusion" refers to a protrusion comprising a base and a shank that extends from the backing of a male component of a mechanical fastening system, and is non-perpendicular to a male component backing.

5 "Comprises", "Comprising" and other derivatives from the root term "comprise" are intended to be open-ended terms that specify the presence of any stated features, elements, integers, steps, or components, but do not preclude the presence or addition of one or more other features, elements, integers, steps, components, or groups thereof. Accordingly, such terms are intended to be synonymous with the words "has", "have",  
10 "having", "includes", "including" and any derivatives of these words.

"Direction of Fastener Force" refers to a force exerted by the male component on the female component while the components are engaged (e.g. while the article embodying the fastener is being worn). The fastener force is a vector force having a  
15 shear force component and a normal force component.

"Engaging Portion" refers to a part of a fastening component that is suitably shaped to enable the fastening component to engage or secure itself to a complementary fastening component. Examples of engaging portions include J-shaped hooks, and flat-  
20 topped hook portions atop protrusions having a diameter narrower than the flat top.

"Extensible Material" refers to a material that can provide a substantially permanent deformation of at least about 10 percent, desirably at least about 15 percent, particularly at least about 17 percent, more desirably at least about 20 percent, even more  
25 desirably at least about 25 percent, and yet even more desirably at least about 30 percent when subjected to a tensile force of 100 gmf per inch (per 2.54 cm) of width according to the Material Elongation and Deformation Tensile Test set forth herein. In general, the Material Elongation and Deformation Tensile Test is conducted similar to ASTM Standard Test Method D882 (Tensile Method for Tensile Properties of Thin Plastic Sheeting) dated  
30 December 1995. The initial separation of the jaws of the tensile tester is 3 inches (76.2 mm) at a tensile force of about 1 gram force per inch of width of the test sample, and the moving jaw is moved at a constant rate of 127 mm/min. The moving jaw is stopped at an extension where the tensile force equals 100 grams force per inch of width of the test  
35 sample, held at that extension for a period of 2 minutes, and then returned back to its initial tensile force of about 1 gram force per inch of width of the test sample at a rate of 127 mm/min.



"Knitted Fabric" refers to a cloth constructed by interlocking a series of loops of one or more yarns by hand or by machine, by a knitting process. Three main classes of knit fabrics are circular knit, flat knit and warp knit. Examples of the last type of knit include  
5 *Tricot, Milanese* and *Raschel* knit.

"Knitting Process" refers to a method of constructing fabric by interlocking series of loops of one or more yarns.

10 "Meltblown Fibers" means fibers formed by extruding a molten thermoplastic material through a plurality of fine, usually circular, die capillaries as molten threads or filaments into converging high velocity heated gas (e.g., air) streams which attenuate the filaments of molten thermoplastic material to reduce their diameter, which may be to  
15 microfiber diameter. Thereafter, the meltblown fibers are carried by the high velocity gas stream and are deposited on a collecting surface to form a web of randomly dispersed meltblown fibers. Such a process is disclosed for example, in U.S. Pat. No. 3,849,241 to Butin et al. Meltblown fibers are microfibers which may be continuous or discontinuous, are generally smaller than 10 microns in diameter, and are generally self bonding when deposited onto a collecting surface. Meltblown fibers used in the present invention are  
20 preferably substantially continuous in length.

As used herein, the term "Non-elastic", what is meant is that the sheet layers are made from polymers that are generally considered to be inelastic. In other words, use of such inelastic polymers to form the sheet layers would result in sheet layers that are not  
25 elastic. As used herein, the term "Elastic" means any material which, upon application of a biasing force, is stretchable, that is, elongatable, at least about 60 percent (i.e., to a stretched, biased length which is at least about 160 percent of its relaxed unbiased length), and which will immediately recover at least 55 percent of its elongation upon release of the stretching, elongating force.

30

As used herein, the term "Non-woven" means a fabric or web having a structure of individual fibers or threads which are interlaid, but not in a regular or identifiable manner as in a knitted textile or woven textile fabric. Non-woven fabrics or webs have been formed from many processes such as, for example, melt-blowing processes, spunbonding  
35 processes, air laying processes, and bonded carded web processes. The basis weight of non-woven fabrics is usually expressed in ounces of material per square yard (osy) or

grams per square meter (gsm) and the fiber diameters useful are usually expressed in microns. (Note that to convert from osy to gsm, multiply osy by 33.91.)

5 "Perpendicular Direction" or "Perpendicular Force Direction" refers to a direction normal (90 degrees) to a backing material or other reference surface. The perpendicular direction is perpendicular to the shear direction, defined below.

10 "Perpendicular Force", or "peel force" refers to forces that tend to produce an opposite pulling motion in a perpendicular direction between two bodies' planes.

"Polymers" include, but are not limited to, homopolymers, copolymers, such as for example, block, graft, random and alternating copolymers, terpolymers, etc. and blends and modifications thereof. Furthermore, unless otherwise specifically limited, the term "polymer" shall include all possible geometrical configurations of the material. These configurations include, but are not limited to isotactic, syndiotactic and atactic symmetries.

15 "Releasably Attached," "Releasably Engaged" and variations thereof refer to two elements being connected or connectable such that the elements tend to remain connected absent a separation force applied to one or both of the elements, and the elements being capable of separation without substantial permanent deformation or rupture. The required separation force is typically beyond that encountered while wearing the garment item.

25 "Resilient" refers to a material that is flexible, compressible and re-formable.

"Shear Force" refers to forces that tend to produce an opposite but parallel sliding motion between two bodies' planes.

30 "Shear Direction" or "Shear Force Direction" refers to a direction parallel to a backing material or other reference surface undergoing shear force.

As used herein, the term "Spunbonded Fibers" refers to small diameter fibers which are formed by extruding molten thermoplastic material as filaments from a plurality of fine capillaries of a spinnerette having a circular or other configuration, with the diameter of the extruded filaments then being rapidly reduced as by, for example, in U.S. Pat. No. 4,340,563 to Appel et al., and U.S. Pat. No. 3,692,618 to Dorschner et al., U.S.

Pat. No. 3,802,817 to Matsuki et al., U.S. Pats. No. 3,338,992 and 3,341,394 to Kinney, U.S. Pat. No. 3,502,763 to Hartmann, U.S. Pat. No. 3,502,538 to Petersen, and U.S. Pat. No. 3,542,615 to Dobo et al., each of which is incorporated herein in its entirety by reference. Spunbond fibers are quenched and generally not tacky when they are  
5 deposited onto a collecting surface. Spunbond fibers are generally continuous and of-ten have average diameters larger than about 7 microns, more particularly, between about 10 and 30 microns.

“Thermoplastic” describes a material that softens when exposed to heat and which  
10 substantially returns to a nonsoftened condition when cooled to room temperature.

“Water-permeable Porous Films” refers to films rendered porous by puncturing or aperturing, and to films rendered porous by mixing polymer with filler, forming a film from the mixture, and stretching the film.

15 “Woven Fabric” refers to fabric that is formed by a weaving process of interlacing of at least two sets of yarns. Woven fabric may be composed of two sets of yarns, warp and filling. Woven fabrics may be composed of three sets of yarn to provide a triaxial weave. Two dimensional woven fabrics may be composed of two or more warps and  
20 fillings in a fabric, depending on the complexity of the construction of the fabric. The manner in which the two sets of yarn are interlaced determines the weave. The weaving process may include one or more basic weaves, such as plain, twill, and satin.

“Yarn” refers to a continuous strand of textile fibers, filaments, or material in a form  
25 suitable for knitting, weaving, or otherwise intertwining to form a textile fabric. Yarn may be provided in the following forms: (1) a number of fibers twisted together (spun yarn); (2) a number of filaments laid together without twisting (a zero-twist yarn); (3) a number of filaments laid together with a degree of twist; (4) a single filament with or without twist (a monofilament); or, (5) a narrow strip of material, including but not limited to, paper, plastic  
30 film, or metal foil, or metal foil, with or without twist, intended for use in a textile construction.

These terms may be defined with additional language in the remaining portions of the specification.

35

Detailed Description Of The  
Presently Preferred Embodiments

The present invention is directed to a mechanical fastening system that includes a  
5 male component and a female component. In the present invention, a male component of  
a mechanical fastening system, such as hook and loop fastener system, may be fastened  
to a variety of different materials serving as a female component and may remain securely  
fastened to the female component under effective levels of shear force. The materials  
may include fabrics, such as: (i) woven textile fabrics; (2) knitted textile fabrics; and, (3)  
10 non-woven materials. For the purposes of the present invention, the term "fabrics" is used  
to refer to woven, knitted, and non-woven webs.

The present invention may also be directed to a male component of a mechanical  
fastening system that may be easily released or disengaged from the female component  
15 under the effective levels of peel force without causing noticeable damage or distortion to  
the loop material, and may be securely re-attached if needed after several engagement –  
disengagement cycles. The male component includes protrusions wherein at least a  
portion of the protrusions may extend from a backing material at an angle toward the  
direction of fastener shear force. The geometry of the male component can also reduce or  
20 eliminate the occurrence of red-marking and/or irritation if brought into contact with a  
person's skin during use of the disposable absorbent article.

The male component of mechanical fastening system of the present invention may  
be utilized when a material comprising the male component would be attached in a  
25 refastenable manner to a garment or an undergarment material. Examples of applications  
of this particular type of mechanical fastener include, but are not limited to using a male  
component of the present invention to:

(1) refastenably attach a shoulder strap or another part of an undergarment, e.g.  
30 brassiere, to the undersurface of an overlying garment or used to attach any piece of one  
garment, e.g. an undergarment such as panties or breast caps, to overlying garments,  
thereby preventing shifting during use;

(2) secure a disposable absorbent article, such as an adult incontinence pad or a  
35 feminine care pad, to the wearer's undergarment;

(3) adjust the waistline of a garment or an undergarment by either tightening or un-tightening waistline band or waistline flaps, and re-attaching them to the garment and/or to themselves at a desirable waistline width or used to close and/or adjust width of collars, sleeve cuffs, or leg cuffs of garments;

5

(4) attach various functional and fashionable additions to a garment article, e.g. additional pockets, re-attachable sleeves, re-attachable hoods, or seasonal decorative appliqués, such as pumpkin or autumn leaf shapes for Thanksgiving, or used to create a wide variety of fashionable, decorative designs from the same basic piece of garment;

10

(5) make creativity toys for kids, e.g. animal and alphabet shapes that can be attached to a fabric covered board;

(6) refastenably attach name tags and visitors badges to the garments;

15

It should be appreciated by those skilled in the art that these examples are given for purposes of illustration and are not to be construed as limiting the scope of the application of the present invention.

20

This male component is particularly suitable for use in mechanical fastening systems on disposable absorbent articles in which the fastener force has a significant shear force component during use. The term "disposable absorbent garments" is intended to refer to any disposable garment intended to absorb discharged body fluids. Examples of disposable absorbent garments include diapers, adult incontinence products, training pants, feminine napkins, wound dressings, and the like. For ease of understanding, much of the following description will be made in terms of the use of the mechanical fastening systems of the present invention on disposable absorbent products, such as, feminine care products and disposable diapers. Nonetheless, it is to be understood that the mechanical fastening systems of the present invention are equally suited for use on any other disposable absorbent products or durable products.

30

As shown in **Figure 1**, a male component **20** and a female component **22** may be brought together to be releasably attached, or releasably engaged, to one another. The male component **20** may have a number of individual stems or protrusions **23** extending from a resilient backing material **26**. Similarly, the female component **22** may have a number of individual loops **28** protruding generally perpendicularly from a resilient loop

35

backing material **30**. It is understood, as used herein, the female component **22** may comprise a part or a component of a garment article; alternatively, the female component **22** may comprise a part or a component of the disposable absorbent article **10** or a knitted textile fabric, woven textile fabric, and/or non-woven web that the disposable absorbent article **10** comes in contact with during use. The individual protrusions **23** of the male component **20** and the loops **28**, such as individual fibers or bangles of fibers, of the female component **22**, when brought into contact with one another, engage or interlock with one another, with the protrusions **23** of the male component **20** latching onto the loops **28** of the female component **22**, until forcibly separated, thereby pulling the protrusions **23** of the male component **20** out of the loops **28** of the female component **22**. The male and/or female components **20** and **22**, respectively, may be attached to the disposable absorbent article **10** or to a peripheral portion thereof, such as wing structures.

In some embodiments of the present invention, the individual loops **28** of the female component **22** may be needled, stitched or otherwise projected through the loop backing material **30**. The loop backing material **30**, or alternatively, the female component **22** may suitably be made from a non-woven material. In another embodiment of the present invention, the female component **22** may suitably be made from a fibrous non-woven web such as a spunbond non-woven web, or a staple fiber carded web. An example of a suitable non-woven web is disclosed in U.S. Patent No. 5,858,515 to Stokes, et. al, and is hereby incorporated by reference. Alternatively, the individual loops **28** may be made of yarn or tow. Once the loops **28** have been formed, fibers forming the loops **28** may be anchored in place by bonding the fibers to the loop backing material **30** with heat and/or adhesives or any other suitable means. Such suitable female components **22** are available from Velcro, USA, of Manchester, New Hampshire. Alternatively, the female component **22** may be a woven or knitted textile fabric, such as one of the fabrics conventionally used for garment or underwear manufacturing. It is to be understood that the individual loops **28** may not protrude from the surface of the female component **22** but may be an integral part of a fabric, as in typical knitted textile fabric, woven textile fabric, or non-woven webs.

At least some of the individual angled protrusions **24** of the male component **20** of the present invention may be angled, at least in part, toward the direction of fastener shear force. As used herein, the term "direction of fastener shear force" refers to a shear component of a direction, i.e., the direction of fastener force, which a male component **20** applies to a mating female component **22** when the male and female components **20** and

22, respectively, are engaged and under tension. **Figure 2** shows the male component **20** and the female component **22** of **Figure 1** in an engaged position under tension, wherein part of the male and female components **20** and **22** are undergoing disengagement. The direction of fastener force is indicated by arrow **32** in **Figures 1** and **2**. The direction of fastener shear force is indicated by arrow **31** in **Figures 1** and **2**. The direction of a perpendicular peel force component of the fastener force is indicated by arrow **33** in **Figures 1** and **2**. As shown in **Figure 1** and **2**, as typically observed during use, the shear component of the force acting on the mechanical fastening system may be much higher than the peel component of the force acting on the mechanical fastening system. The fastener shear force is in direct opposition to shear force exerted by the female component **22** against the male component **20**. If the angled protrusions **24** of the male components **20** are relatively flexible, the loops **28** of the female component **22** may bend the angled protrusions **24** in a direction opposite the direction of their original tilt, as shown in **Figure 2**. Alternatively, the angled protrusions **24** may be relatively stiff, thereby latching the loop **28** between the protrusion **24** and the backing material **26**, as shown in **Figure 5**, and providing for a very secure attachment.

When it is necessary to disengage or unfasten a mechanical fastening system, an unfastening force having a higher perpendicular peel force component than parallel shear force component may be applied to the mechanical fastening system (see **Figure 2a**). The geometry of the angled protrusions **24** and properties of the materials making up the angled protrusions **24** may ensure that the loop **28** are not pulled out from or otherwise damaged during the release stage. The angled protrusions **24** may require only slight deformation, such as bending, to be released, which can be achieved by application of the low-to-moderate levels of perpendicular peel force. Thus, much lower values of forces may be applied to the female component **22** during the separation stage in case of angled protrusions **24** than in case of a conventional hook material-based male component. In order to further reduce or prevent damage to the female component **22** during the release stage, only the materials with the appropriate flexibility characteristics may be chosen for manufacturing of angled protrusions **24**, i.e. materials with Flexural Modulus of between about 331 MPa to about 2,758 MPa (see more detailed discussion of the flexibility of protrusions below), alternatively, about 344.7 MPa to about 2,413 MPa, or alternatively about 413.7 MPa to about 2,344 MPa. The lower limit of the Flexural Modulus may be independently about 331MPa, about 344.7 MPa, about 379.2 MPa, or about 413.7 MPa. The upper limit of the Flexural Modulus may be independently about 2,344 MPa, about 2,413 MPa, or about 2,758 MPa.

For some embodiments of the present invention, the materials may have a Flexural Modulus of between about 331 MPa to about 586 MPa, alternatively, about 338 MPa to about 572 MPa, or alternatively, about 345 MPa to about 552 MPa. The lower limits of the Flexural Modulus may be independently about 331 MPa, about 338 MPa, or about 345 MPa. The upper limit of the Flexural Modulus may be independently about 552 MPa, about 572 MPa, or about 586 MPa.

In some embodiments of the present invention, the materials may have a Flexural Modulus of between about 965 MPa to about 1,379 MPa, alternatively, about 1,034 MPa to about 1,310 MPa, or alternatively, about 1,103 MPa to about 1,241 MPa. The lower limits of the Flexural Modulus may be independently about 965 MPa, about 1,034 MPa, or about 1,103 MPa. The upper limit of the Flexural Modulus may be independently about 1,241 MPa, about 1,310 MPa, or about 1,379 MPa.

In other embodiments of the present invention, the materials may have a Flexural Modulus of between about 1,724 MPa to about 2,344 MPa, alternatively, about 1,793 MPa to about 2,275 MPa, or alternatively, about 1,862 MPa to about 2,206 MPa. The lower limits of the Flexural Modulus may be independently about 1,724 MPa, about 1,793 MPa, or about 1,862 MPa. The upper limit of the Flexural Modulus may be independently about 2,206 MPa, about 2,275 MPa, or about 2,344 MPa.

The angled projections **24** may be able to handle a greater amount of fastener shear force **31** exerted by the female component **22** than typical perpendicular projections **25** because the female component **22** must overcome a greater amount of fastener shear force **31** when the angled projections **24** are angled toward the direction of fastener shear force **31**. Male components **20** having angled projections **24** thereby may result in a more secure fastening system. To address opposite directions of fastener shear force **31** that may be subjected to the mechanical fastening system during use and separation, depending on the directions in which the female component **22** moves during use and during separation from the male component **20**, angled projections **24** are suitably located in opposite directions, as illustrated in **Figure 3**. Furthermore, the angled projections **24** and perpendicular projections **25** reduce the number of sharp ends poking a wearer by pointing sharp ends away from the wearer, and may thus reduce skin irritation often caused by conventional hook structures.



All of the individual protrusions **23** of the male component **20** may be angled protrusions **24** which are angled toward the direction of fastener shear force **32** or, alternatively, some of the individual protrusions **23** may be angled protrusions **24**, angled toward the direction of fastener force **32** and some of the individual protrusions **23** may be perpendicular protrusions **25**, roughly perpendicular to the backing material **26** (and roughly perpendicular to the direction of fastener shear force **31**). A combination of angled protrusions **24** and perpendicular protrusions **25** is shown in **Figure 1** and **Figures 9** and **11**. Individual angled protrusions **24** that are angled non-perpendicular to the backing material **26** are suitably at an angle ( $\alpha$ ) of about 5 degrees to about 85 degrees with respect to the backing material **26** (and the direction of fastener shear force **31**), more suitably at an angle ( $\alpha$ ) of about 15 degrees to about 80 degrees, more suitably at an angle ( $\alpha$ ) of about 15 degrees to about 75 degrees, more suitably at an angle ( $\alpha$ ) of about 20 degrees to about 75 degrees, more suitably at an angle ( $\alpha$ ) of about 30 degrees to about 75 degrees, most suitably at an angle ( $\alpha$ ) of about 35 degrees to about 70 degrees (See **Figures 7a - 7d**). The lower limit of the angle ( $\alpha$ ) of the individual protrusions **23** may be independently about 5 degrees, about 15 degrees, about 20 degrees, about 30 degrees, or about 35 degrees. The upper limit of the angle ( $\alpha$ ) of the individual protrusions **23** may be independently about 85 degrees, about 80 degrees, about 75 degrees, or about 70 degrees.

20

Individual protrusions **25** that are roughly perpendicular to the backing material **26** and direction of fastener shear force **31**, are suitably at an angle ( $\alpha$ ) of about 70 degrees to about 110 degrees with respect to the backing material **26**, more suitably at an angle ( $\alpha$ ) of about 80 degrees to about 100 degrees, and most suitably at an angle ( $\alpha$ ) of about 85 degrees to about 95 degrees. The lower limit of the angle ( $\alpha$ ) of the individual protrusions **25** may be independently about 70 degrees, about 80 degrees, or about 85 degrees. The upper limit of the angle ( $\alpha$ ) of the individual protrusions **25** may be independently about 110 degrees, about 100 degrees, or about 95 degrees.

30

The protrusions **23** of the male component **20** penetrate the surface of or otherwise interact with the female component **22**. The protrusions **23** of the male component **20** may comprise a variety of sizes and shapes. **Figures 7a to 7d** show four side views of different shapes that the protrusions **23** may assume. The protrusions **23** may terminate in tapered ends (see **Figure 7b**) or may comprise conical or pyramidal shapes (see **Figure 7c**). In other embodiments, the protrusions **23** may comprise the shape of a

35

truncated cone or a truncated pyramid (see **Figure 7d**). **Figures 8a to 8g** show seven additional cross-sectional views of shapes that the protrusions **23** may also assume.

It may be desirable that the cross-sectional dimensions of the protrusions **23** of the male components **20** of the present invention are comparable or smaller than the size of the void spaces between the fibers in the female component **22**. The cross-sectional dimensions of the protrusions **23** may range from about 90 to about 500  $\mu\text{m}$ , more specifically from about 130 to about 440  $\mu\text{m}$ , and most specifically from about 160 to about 400  $\mu\text{m}$ . The lower limit of the cross-sectional dimension of the protrusions **23** may be independently about 90  $\mu\text{m}$ , about 130  $\mu\text{m}$ , or about 160  $\mu\text{m}$ . The upper limit of the cross-sectional dimension of the protrusions **23** may be independently about 500  $\mu\text{m}$ , about 440  $\mu\text{m}$ , or about 400  $\mu\text{m}$ . The cross-sectional dimensions of the protrusions **23** may be variable along the length of protrusion as shown in **Figures 6b**, and **7b to 7d**. Such variability in the cross-sectional dimensions of the protrusions **23** may allow the protrusions **23** to penetrate and engage a variety of female components **22** having void spaces of different sizes or variable sizes. In an alternative embodiment, male component **20** may include two or more groups of protrusions **23**, each group of protrusions **23** being characterized by specific cross-sectional dimensions (see **Figures 9** and **11**), thereby enabling the male component **20** to attach to a variety of female components **22**.

20

The angled projections **24** may be more angled along a small portion, such as at one end **27**, as shown in **Figure 6**, or along a substantial length of the angled projection **24**, as shown in **Figures 4** and **5**. The term "substantial length," as used herein, refers to the full length of the angled projection **24**.

25

In accordance with some embodiments, the male components **20** of the present invention may generally have between about 16 and about 930 protrusions **23** per square centimeter, more specifically between about 124 and about 470 protrusions **23** per square centimeter, and most specifically between about 155 and about 310 protrusions **23** per square centimeter. In other embodiments of the present invention, the male components **20** may generally have between about 250 to about 800 protrusions **23** per square centimeter, more specifically between about 350 to about 700 protrusions **23** per square centimeter, and most specifically between about 400 to about 600 protrusions **23** per square centimeter. In other embodiments of the present invention, the protrusions **23** of the male components **20** may form a discontinuous pattern, such as stripes and isolated

35

islands, wherein the number of protrusions **23** may range from about 5 protrusions **23** per square centimeter or greater.

The heights *h* of the protrusions **23** of the male components **20** of the present invention may range from about  $3 \times 10^{-3}$  cm to about 0.9 cm, more specifically from about  $2.4 \times 10^{-2}$  cm to about  $5.5 \times 10^{-2}$  cm, and most specifically from about  $2.8 \times 10^{-2}$  cm to about  $5 \times 10^{-2}$  cm. The lower limit of the height of the protrusions **23** may be independently about  $3 \times 10^{-3}$  cm, about  $2.4 \times 10^{-2}$  cm, or about  $2.8 \times 10^{-2}$  cm. The upper limit of the height of the protrusions **23** may be independently about 0.9 cm, about  $5.5 \times 10^{-2}$  cm, or about  $5 \times 10^{-2}$  cm. (See **Figures 7a to 7d**). The height of the protrusions **23** should provide effective engagement of the protrusions **23** of the male component **20** and the female component **22**.

The protrusions **23** may be formed by injection molding, cavity molding, profile extrusion, or any other fabricating process known in the art. For example, the protrusions **23** may be suitably molded or extruded using a continuous molding process, in which a plastic resin strip base is molded with integral fastener elements in the form of protrusions extending from one surface. Such molding may be performed in a high pressure nip, such as between two counter-rotating rollers or against a single roller that defines miniature cavities in its peripheral surface, the cavities may be shaped in such a way that the cavities would be suited for molding any shape of the protrusions **23**, including the shapes shown in **Figures 6 and 7a - d**. One process is described in the U.S. Patent No. 4,794,028, issued on December 27, 1988 to Fisher, and incorporated herein by reference to the extent it is consistent herewith. Alternatively, a method of in situ lamination of protrusions **23** to the backing material **26** may be used, as disclosed in U.S. Patent No. 5,260,015, issued on November 9, 1993 to Kennedy et. al., and incorporated herein by reference to the extent it is consistent herewith. The materials for making the protrusions **23** may be selected from a group of thermoplastic polymers such as polyamides, polyesters, poly(vinyl acetate), PVC, polyolefins (e.g. polyethylene, polypropylene, polybutene, ethylene copolymers, propylene copolymers, or butene copolymers), a thermoplastic elastomer, or another suitable material and mixtures thereof.

The Flexural Modulus of the material from which the protrusions **23** may be suitably molded or extruded should be in the range from about 331 MPa to about 2,758 MPa. As used herein, the term "Flexural Modulus" is used as an equivalent of a term "Modulus of Elasticity in Bending" and refers to a characteristic of the flexural properties of

plastics determined according to ASTM D 790-99 "Standard Test Methods for Flexural Properties of Unreinforced and Reinforced Plastics and Electrical Insulating Materials". Protrusions **23** having such flexural modulus provides for acceptable engagement with the female component **22** while maintaining flexibility to allow disengagement from the female component **22** without causing significant damage. Other parameters of the protrusions **23** that may affect the flexibility, engagement and disengagement characteristics of the protrusions **23** include, but are not limited to: (a) the length/height of a protrusion **23**; (b) the angle  $\alpha$  between the protrusion **23** and the backing material **26**; and, (c) the cross-sectional area (or shape) of the protrusions **23**. As the cross-sectional area of protrusions **23** is increased (e.g., thicker stems), the flexibility of the protrusions **23** may decrease. To compensate for reduced flexibility of the protrusions **23**, selection of materials having lower Flexural Modulus may be made. Likewise, when the angle  $\alpha$  between the protrusions **23** and the backing material **26** is decreased, or when the length of protrusions **23** is increased, the selection of materials having an appropriate Flexural Modulus may be needed to provide protrusions **23** of desired flexibility. For example, materials having a lower Flexural Modulus to increase the flexibility of the protrusions **23**, thereby and thus avoid significant separation forces acting on the female component **22** during disengagement.

The protrusions **23** may be comprised of more than one material. In some embodiments of the present invention, the protrusions **23** may be made of one polymer or material that may provide a desired trait or characteristic and be coated with another polymer or material that may provide an additional trait or characteristic. For example, the protrusion **23** may be comprised of polypropylene which may provide a mechanical strength. Such a protrusion **23** may then be coated with a pliable or elastomeric material, such as a silicone rubber, ethyl-vinyl-acetate (EVA), homo- and co- polymers of isoprene, homo- and co- polymers of butadiene, and the like, to provide a softer, more skin-friendly surface and a surface with a higher coefficient of friction, such as materials with a coefficient of friction higher than 1.

Alternatively, the method of manufacture may be modified by using at least two different polymers **38** and **40** aligned side-by-side along a length of the protrusion mold. When the polymers **38** and **40** are heated, all of the polymers **38** and **40** should be heat softened. In some embodiments of the present invention, the polymers **38** and **40** may be chosen such that one polymer **38** shrinks more than the other polymer **40** or other polymers during the cooling process. Thus, when the polymers **38** and **40** cool, the

polymer **38** that shrinks more lowers the protrusion **24** toward the backing material **26** while the polymer **40** that shrinks less forms a surface away from the backing material **26**, as shown in **Figure 10**.

5           The backing material **26** may be made of any of the materials that comprise the protrusions **23** or any other suitable materials. The backing material **26** may be made of the same or a different material than the protrusions **23** of the male component **20**. The backing material **26** may generally have a thickness in a range of between about 0.1 millimeter (mm) and about 5 mm, suitably in a range of between about 0.6 mm and 2 mm,  
10           resulting in a total basis weight of the male component **20** in a range of from about 20 grams per square meter to about 200 grams per square meter. In various embodiments of the present invention, the backing material **26** may comprise a film, a paper, a knit fabric, woven, needle punched non-woven, spunbond, point-unbonded non-woven material (PUB), neck bonded laminate (NBL), spunbond/meltblown/spunbond multi-layer laminate,  
15           air laid non-woven, air-formed non-woven, and the like.

          The protrusions **23** of the male component **20** of the present invention may be spatially arranged in rows with spacers **29** between the rows, as shown in **Figure 3**. These spacers **29** may be in the form of bumps, ridges, depressions, or any other suitable  
20           distortion made in or added to the backing material **26**. These spacers **29** may improve the overall flexibility of the backing material **26** by providing areas of lower density among the individual protrusions **23** where the backing material **26** may easily bend to conform to a wearer's body as the body moves. Furthermore, the spacers **29** may also improve the flexibility of individual protrusions **23** by providing room for the individual protrusions **23** to  
25           bend in response to applied pressure. Alternatively, the rows of protrusions **23** may be separated by a flat surface. Also, as mentioned, the protrusions **23** may be suitably arranged such that a plurality of the protrusions **23** face one direction and a plurality of the protrusions **23** may face an opposite direction or a different direction in order to  
30           compensate for directions of fastener forces in opposite/different directions. See **Figures 9 to 10** and **Figures 14a to 14b** for examples of possible orientations of angled protrusions. In other embodiments of the present invention, the angled protrusions **24** of the male component **20** may be randomly oriented in different directions. The orientations may be in the machine direction (MD) and/or cross-machine direction (CD) and any orientation therebetween.

35

Examples**Example 1**

5           It may be desirable that the spatial parameters of the protrusions **23** of the male component **20** of the present invention, such as their cross-sectional dimensions, length, height and surface density be designed taking in the account properties of the targeted female component **22** or a group of targeted female components **22**.

10       The samples of materials taken from feminine undergarments analyzed were:

1. Samples of black knitted nylon material, commercially available under the trade designation of "non-cling Tricot 40 denier Antron III sanitized", purchased from Kieffer's Company, located at P.O. Box 719, Jersey City, New Jersey, 07307.
- 15       2. Samples of 100% black cotton jersey, commercially available under the style/color number 0808-6175 and weight of 6.85 ounce per sq. yard, purchased from Dyersburg Fabric Inc., located at Dyersburg, Tennessee, 38024.
3. Samples of beige satin material taken from various regions of the high-cut Satin ladies briefs sold under Vanity Fair® of the Vanity Fair Corporation located at 105  
20       Corporate Center Blvd., Greensboro, North Carolina, 27408. Briefs were purchased through the J.C. Penney Company.
4. Samples of blue microfiber material taken from various regions of the high-cut microfiber ladies briefs sold under Vanity Fair® of the Vanity Fair Corporation  
25       located at 105 Corporate Center Blvd., Greensboro, North Carolina, 27408. Briefs were purchased through the J.C. Penney Company.

The samples of the materials represent typical types of materials used in feminine undergarments. The samples of the materials represent different types of fibers (synthetic and natural) and different types of weaves (less dense, such as the cotton jersey sample  
30       of material and more dense, such as the satin sample of material).

The following undergarment material parameters were obtained as discussed below:

1. Average pore sizes
- 35       2. Pore size distribution
3. Pore density

4. Weave pattern
5. Average material thickness

5 These parameters were used to establish suitable dimensions for protrusions **23** of a male component **20** capable of engaging materials typically used in feminine undergarments.

Determination of the pore dimensions, pore density, and weave pattern were made by analysis of micro-images of undergarment samples of the materials. The micro-images were obtained using the high-resolution Keyence® Digital Microscope VH-6300  
10 commercially available from Keyence Corporation located at 1-3-14, Higashi-Nakajima, Higashi-Yodogawa-ku, Osaka, 533, Japan. The micro-images were obtained using a magnification of 50X for the pore density determination, and a magnification of 175X for the pore size determination. All measurements were taken while the samples of material were experiencing no stress or elongation forces.

15

The pore size determination of each sample of material was accomplished using the "Measure" option on the controller unit of the microscope. Before each measurement, a calibration of distance was performed for measurement accuracy. To measure the size of a pore, a Keyence® VH-6300 Camera unit (complimentary to the Keyence® Digital  
20 Microscope) was focused on the sample of material being analyzed so that the image of the sample was displayed clearly on the monitor screen. A pore region was then secluded by a polygon shape outlining the shape of the pore region being measured. Measurement of the polygon area was performed by using "Area" option on the controller menu of the microscope. The measurement was repeated at least 50 times. At least three pieces of  
25 each sample of material were used for measurement, from different regions of the sample of material. An average value of the measurements was calculated. For simplification of the calculations, different polygon shapes representing different pore shapes were approximated by circles of equal area, and the circle diameter was used as a parameter characterizing pore size of any particular pore. FREQUENCY function in Excel® software  
30 (a part of the standard Microsoft Office Software Package) was used to analyze pore sizes distribution.

The determinations of pore density and weave pattern of each sample of material was accomplished using micro-images of 50x magnification. The micro-images were  
35 made using the high-resolution Keyence® Digital Microscope VH-6300. The "X-Y distance" option on a controller menu was used to determine the distances between the

adjacent pores in X and Y directions of each sample of material. The measurement was repeated at least 15 times. At least three pieces of each sample of material were used for measurement, from up to 5 different regions of the sample of material. An average value of the measurements was calculated. Standard deviations were calculated using Excel®.

5

The thickness of each sample of material was measured using digital thickness tester from SONY at 1.38 kPa. The measurement was repeated at least 15 times. At least three pieces of each sample of material were used for measurement, from up to 5 different regions of the sample of material. An average value of the measurements was calculated.

10

**Figures 15a - 15c** show the pore size distributions for the different types of materials, cotton, nylon, microfiber and satin. The cotton, nylon, and microfiber materials were all showing broad bi-modal distributions of pore sizes, reflecting the fact that these materials, with a complex weave pattern, had two types of pores, large and small (as shown in **Figures 16a - 16d**). The satin material showed a more uniform unimodal pore size distribution consistent with its more uniform weave pattern (see **Figure 12** and **Figure 16d**). The average pore sizes for all four materials are summarized in **Table 1**.

15

20

Differences in weave patterns of different materials are more easily observed in the microphotographs of the materials presented in **Figures 12a - 12d**. **Figure 12a** is a microphotograph of the nylon sample of material. **Figure 12b** is a microphotograph of the cotton sample of material. **Figure 12c** is a microphotograph of the microfiber sample of material. **Figure 12d** is a microphotograph of the satin sample of material. The weave patterns of the four samples of material were different. The weave pattern of the cotton sample of material was the least dense and the weave pattern of the satin sample of material was the most dense. The cotton sample of material also exhibited a higher degree of 'fuzziness' due to single fibers projecting from the yarns. Schematic drawings of void patterns for the four samples of the materials are shown in **Figures 16a - 16d**. To quantify densities of the weave patterns of the four samples of materials, the number of pores per square inch was determined for each sample. The determination was accomplished by measuring average distances between the adjacent pores in both the MD and CD directions. The average pore densities are provided in **Table 1**. Densities of the samples of materials as determined are: Cotton < Microfiber ≤ Nylon < Satin.

25

30



The cotton sample of material was about 2.5 times less dense than the microfiber sample of material, while the satin sample of material was about 2.7 times more dense than the nylon sample of material.

- 5 The results of the thickness determination of the samples of the materials are also provided in **Table 1**.

**Table 1.**

	Nylon	Cotton	Microfiber	Satin
<u>Pore Sizes</u>				
Ave. Dia., $\mu\text{m}$	150	380	158	196
Min. Dia., $\mu\text{m}$	93	280	107	151
Max. Dia., $\mu\text{m}$	228	462	226	239
Std dev., $\mu\text{m}$	31	48	38	21
<u>AVE. Distance Between Pores:</u>				
in CD, $\mu\text{m}$	545	1,022	407	240
Std dev., $\mu\text{m}$	20	37	1	2
in MD, $\mu\text{m}$	485	702	706	392
Std dev., $\mu\text{m}$	33	15	3	5
<u>Pore Surface Density</u>				
Ave. density, voids/cm <sup>2</sup>	757	279	696	2,129
Std dev., voids/cm <sup>2</sup>	52	6	3	24
Ave. density, voids/inch <sup>2</sup>	4,882	1,800	4,490	13,136
Std dev., voids/inch <sup>2</sup>	332	38	19	144
<u>Thickness</u>				
Ave. thickness, $\mu\text{m}$	280	680	300	300
Std dev., $\mu\text{m}$	20	20	30	30

10

- Suitable designs and dimensions of the male component **20** capable of engaging with various female components **22** having different pore sizes, pore densities, weave patterns, and thicknesses are described below. Suitable cross-sectional dimensions of protrusions **23** and **25** of the male component **20** may have comparable cross-sectional dimensions of material voids within the female component **22**. If the cross-sectional dimensions of the protrusions **23** and/or **25** of the male component **20** differ significantly from the cross-sectional dimensions of the material voids within the female component **22** (greater or less than), the engagement may fail. If the cross-sectional dimension of the

protrusions **23** and/or **25** of the male component is significantly greater than the material voids within the female component **22**, the protrusions **23** and/or **25** may not be able to penetrate the female component **22**. If the cross-sectional dimension of the protrusions **23** and/or **25** of the male component **20** is significantly less than the material voids within the female component **22**, the engagement of the male component **20** and female component **22** may not be able to be maintained during use. The cross-sectional dimensions of protrusions **23** and/or **25** of the male component **20** may be within the range between about 90  $\mu\text{m}$  to about 470  $\mu\text{m}$ , alternatively about 100  $\mu\text{m}$  to about 460  $\mu\text{m}$ , or alternatively about 110  $\mu\text{m}$  to about 450  $\mu\text{m}$ . The lower limit of the cross-sectional dimension of the protrusions **23** and/or **25** of the male component **20** may be independently about 90  $\mu\text{m}$ , about 100  $\mu\text{m}$ , about 110  $\mu\text{m}$ , or about 120  $\mu\text{m}$ . The upper limit of the cross-sectional dimension of the protrusions **23** and/or **25** of the male component **20** may be independently about 440  $\mu\text{m}$ , about 450  $\mu\text{m}$ , about 460  $\mu\text{m}$ , or about 470  $\mu\text{m}$ .

The protrusions **23** and/or **25** of the male component **20** may include a variety of cross-sectional shapes, such as cones, pyramids, tapered cones, tapered pyramids, truncated cones, and the like. Wherein the protrusions **23** and/ **25** have a tapered shape, such protrusions **23** and/or **25** may more easily penetrate or otherwise engage a wider variety of different female components **22** characterized by different pore sizes and other characteristics affecting penetration and engagement by protrusions **23** and/or **25**. This may be explained by the varying cross-sectional dimension through the length of the protrusion **23** and/or **25**.

In other embodiments of the present invention, the male component **20** may include more than one type of protrusions **23** and/or **25**. Each type of protrusions **23** and/or **25** may have cross-sectional dimensions and/or cross-sectional shapes that may be corresponding to a particular range of material voids within a female component **22**. As such, the male component **20** may demonstrate improved engagement with a variety of different female components **22**. In some embodiments of the present invention, similar protrusions **23** and/or **25** may be positioned within islands, stripes, or other configurations on the surface of the male component **20**.

In some embodiments of the present invention, the height of protrusions **23** and/or **25** of the male component **20**, as measured from the base to the tip of the protrusions **23** and/or **25** may be less than the thickness of female component **22**. Such a configuration of the protrusions **23** and/or **25** may avoid direct skin contact, and thus, skin irritation, with

the protrusions **23** and/or **25** of the male component **20**. In some embodiments of the present invention, the heights of the protrusions **23** and/or **25** of the male component **20** may be about 250  $\mu\text{m}$  to about 700  $\mu\text{m}$ , alternatively about 280  $\mu\text{m}$  to about 680  $\mu\text{m}$ , or alternatively about 300  $\mu\text{m}$  to about 670  $\mu\text{m}$ . The lower limit of the height of the protrusions **23** and/or **25** of the male component **20** may be independently about 200  $\mu\text{m}$ , about 250  $\mu\text{m}$ , about 275  $\mu\text{m}$ , or about 300  $\mu\text{m}$ . The upper limit of the cross-sectional dimension of the protrusions **23** and/or **25** of the male component **20** may be independently about 700  $\mu\text{m}$ , about 690  $\mu\text{m}$ , about 680  $\mu\text{m}$ , or about 670  $\mu\text{m}$ .

The surface density, the number of protrusions **23** and/or **25** per square centimeter of the male component **20**, may range from about 270 prot./cm<sup>2</sup> to about 2,200 prot./cm<sup>2</sup>, alternatively about 290 prot./cm<sup>2</sup> to about 2,000 prot./cm<sup>2</sup>, alternatively about 300 prot./cm<sup>2</sup> to about 1,800 prot./cm<sup>2</sup>, or alternatively about 320 prot./cm<sup>2</sup> to about 1,600 prot./cm<sup>2</sup>. The lower limit of the surface density of the male component **20** may be independently about 250 prot./cm<sup>2</sup>, about 270 prot./cm<sup>2</sup>, about 290 prot./cm<sup>2</sup>, about 300 prot./cm<sup>2</sup>, or about 320 prot./cm<sup>2</sup>. The upper limit of the surface density of the male component **20** may be independently about 2,200 prot./cm<sup>2</sup>, about 2,000 prot./cm<sup>2</sup>, about 1,800 prot./cm<sup>2</sup>, or about 1,600 prot./cm<sup>2</sup>.

20

### Example 2

To illustrate the correlation between the separation forces acting on a mechanical fastener during disengagement and the level of damage to the female component, a testing of the forces experienced by the mechanical fastening system during the disengagement in peel and shear mode was conducted. Tests were conducted using a standard tensile frame Model Number Sintech I/S, serial No. 7190, equipped with TestWorks for Windows software from MTS Systems Corporation located at P.O. Box 24012, Minneapolis, Minnesota, 55424, in accordance with the manufacturer's manual. The 50 N transducer was used together with the tensile frame to measure forces, and the instrument was calibrated for this transducer before each test. The loop material was in the form of knitted nylon material, commercially available under the trade designation "non-cling Tricot 40 denier Antron III sanitized", manufacturer part number 4500 T "Antron" III, purchased from Kieffer's Co. located at P.O. Box 719, Jersey City, New Jersey, 07307. The material was cut in 2" X 8" (51 mm X 203 mm) samples for the peel test. For the purpose of repeatability of the force measurements, male component was always

engaged to the loop material by rolling the sample with a mechanical roll-down unit providing a pressure of 2 kg twice at a speed of 4.9 mm/s. The material was peeled from the male component of a mechanical fastener at a 180-degree angle and at a peel speed of 20 inches/minute (8.47 mm/s) and the resulting peel force was recorded. In a separate series of tests, the material was separated from the male component in shear mode at a speed of 20 inch/minute (8.47 mm/s) and the resulting shear force was recorded.

**Table 2.** Average peel forces measured during disengagement of the male component 20 from the female component 23 by peel forces and resulting levels of loop damage.

No.	Code name	Average force during disengagement by peel, N/m	Level of damage to the loop material
1	100-7003	2.3	No
2	102-7004	3.9	No
3	102-7003	4.6	No
4	100-7005	5.2	No
5	102-1002	7.4	No
6	61-1036	7.7	No
7	102-7006	9.4	no
8	100-1001	12.3	no
9	61-1035	12.7	no
10	102-7005	19.0	no
11	103-7005	22.8	slight
12	103-1001	24.7	slight
13	102-1001	47.8	moderate
14	38-1002	235.4	severe

	Code	Protrusion Shape	Angle $\alpha$	Protrusion Density (prot./cm <sup>2</sup> )	Flexural Modulus (MPa)
5	38-1002	see Figure 6b	37°	182	
	61-1035	see Figure 6a	90°	455	2,034±310
	61-1036	see Figure 6a	90°	455	
	100-1001	see Figure 6b	60°	672	2,034±310
	100-7003	see Figure 6b	60°	672	448±138
10	100-7005	see Figure 6b	60°	672	1,172±207
	102-1001	see Figure 6b	60°	336	2,034±310
	102-1002	see Figure 6b	75°	336	2,034±310
	102-7003	see Figure 6b	60°	336	448±138
	102-7004	see Figure 6b	75°	336	448±138
15	102-7005	see Figure 6b	60°	336	1,172±207
	102-7006	see Figure 6b	75°	336	1,172±207
	103-1001	see Figure 6a	60°	336	2,034±310
	103-7005	see Figure 6a	60°	336	1,172±207

20

As shown in Table 2, the loop material 30 did not experience any damage if the average peel force during disengagement was lower than about 22.8 N/m. It was further demonstrated that when the average peel force was above about 22.8 N/m but below about 47.8 N/m only a slight impact on the loop material 30 was observed resulting in a slight increase of fuzziness of the surface of the loop material 30. However when the average peel force during disengagement was about 47.8 N/m or higher, a moderate amount of damage to the loop material 30 was observed resulting in a noticeable string-out and fiber pull-out, and a significant increase of fuzziness of the surface of the loop material 30, so that the area where a male component 20 was attached became clearly noticeable and different in appearance from the rest of the female component 22. It was further demonstrated that when the average peel force reached the level of about 235.4 N/m or higher, a severe damage to the female component 22 was observed. The level of damage was comparable to the damage caused to the loop material 30 by the conventional hook material as demonstrated in Figures 13a - 13b.

35

It is to be understood that the present invention is aimed at the male component 20 of the mechanical fastener that can only cause no impact or slight impact on the female component 22. Thus, the male component 20 of the present invention may exert a peel force on a nylon female component 22 that ranges from about 0.2 N/m to about 47.8 N/m, alternatively about 0.4 N/m to about 47.5 N/m, alternatively about 0.8 N/m to about 47.1 N/m, or alternatively about 2.3 N/m to about 46.3 N/m. The lower limit of the peel force may be independently about 0.2 N/m, about 0.4 N/m, about 0.8 N/m, or about 2.3 N/m.

The upper limit of the peel force may be independently about 46.3 N/m, about 47.1 N/m, about 47.5 N/m, or about 47.8 N/m.

**Table 3** provides data of the shear forces measured during the separation of the male component **20** from the female component **22** in the shear mode. The female component **22** was the sample of material of nylon. No significant damage, as discussed above, was recorded during the separation of the male component **20** from the female component **22** under the application of peel force. In some embodiments of the present invention, the shear force during the separation of the male component **20** from the female component **22** in the shear mode may be in the range from about  $6.08 \times 10^3$  N/m<sup>2</sup> to about  $2.43 \times 10^4$  N/m<sup>2</sup>, alternatively about  $6.38 \times 10^3$  N/m<sup>2</sup> to about  $2.42 \times 10^4$  N/m<sup>2</sup>, alternatively about  $6.68 \times 10^3$  N/m<sup>2</sup> to about  $2.40 \times 10^4$  N/m<sup>2</sup>, or alternatively about  $7.00 \times 10^3$  N/m<sup>2</sup> to about  $2.34 \times 10^4$  N/m<sup>2</sup>. The lower limit of the peel force may be independently about  $6.08 \times 10^3$  N/m<sup>2</sup>, about  $6.38 \times 10^3$  N/m<sup>2</sup>, about  $6.68 \times 10^3$  N/m<sup>2</sup>, or about  $7.00 \times 10^3$  N/m<sup>2</sup>. The upper limit of the peel force may be independently about  $2.43 \times 10^4$  N/m<sup>2</sup>, about  $2.42 \times 10^4$  N/m<sup>2</sup>, about  $2.40 \times 10^4$  N/m<sup>2</sup>, or about  $2.34 \times 10^4$  N/m<sup>2</sup>.

**Table 3.** Average Shear Forces Measured during Disengagement of the Male Component **20** from the Female Component **23** Shear Mode.

20

No.	Code name	Average force during disengagement by shear, N/m <sup>2</sup>
1	100-7003	$6.38 \times 10^3$
2	102-7004	$4.56 \times 10^3$
3	102-7003	$6.99 \times 10^3$
4	100-7005	$2.28 \times 10^4$
5	102-1002	$1.28 \times 10^4$
6	61-1036	$7.29 \times 10^3$
7	102-7006	$1.73 \times 10^4$
8	100-1001	$1.73 \times 10^4$
9	61-1035	$1.99 \times 10^4$
10	102-7005	$2.37 \times 10^4$
11	103-7005	$2.64 \times 10^4$
12	103-1001	$2.34 \times 10^4$

It will be appreciated that details of the foregoing embodiments, given for purposes of illustration, are not to be construed as limiting the scope of this invention. Although only a few exemplary embodiments of this invention have been described in detail above, those skilled in the art will readily appreciate that many modifications are possible in the exemplary embodiments without materially departing from the novel teachings and advantages of this invention. Accordingly, all such modifications are intended to be included within the scope of this invention, which is defined in the following claims and all equivalents thereto. Further, it is recognized that many embodiments may be conceived that do not achieve all of the advantages of some embodiments, particularly of the preferred embodiments, yet the absence of a particular advantage shall not be construed to necessarily mean that such an embodiment is outside the scope of the present invention.

**WE CLAIM:**

1. A mechanical fastening system comprising:  
a male component including a backing material and at least a plurality of  
5 first protrusions extending from the backing material; and,  
a female component capable of engaging the male component,  
wherein at least a portion of the plurality of first protrusions extend from the backing  
material of the male component form an angle  $\alpha$  from about 5 degrees to about 85  
degrees relative to the backing material of the male component and at least a portion of  
10 the first plurality of protrusions have a Flexural Modulus from about 331 MPa to about  
2,758 MPa.
2. The mechanical fastening system of Claim 1, further comprising at least a  
plurality of second protrusions extending from the backing material wherein at least a  
15 portion of the plurality of second protrusions extend from the backing material of the male  
component at an angle  $\alpha$  of about 95 degrees to about 175 degrees relative to the backing  
material of the male component.
3. The mechanical fastening system of Claim 1 or Claim 2, wherein the female  
20 component further comprises material selected from the group of fabrics consisting  
essentially of: woven textile fabric; knitted textile fabric; non-woven web; and,  
combinations thereof.
4. The mechanical fastening system of any of Claim 1 to Claim 3, wherein the  
25 female component further comprises a loop backing material and a plurality of loops or  
fibers extending from the loop backing material.
5. The mechanical fastening system of any of Claim 1 to Claim 4, wherein at  
least a portion of the plurality of the first protrusions have a height from about  $3 \times 10^{-3}$  cm to  
30 about 0.9 cm.



- 6.** The mechanical fastening system of any of Claim 2 to Claim 5, wherein at least a portion of the plurality of the first protrusions are shorter than at least a portion of the plurality of the second protrusions.
- 5       **7.** The mechanical fastening system of Claim 6, wherein the shorter first protrusions are from about 5% to 95% shorter than at least a portion of the plurality of the second protrusions.
- 8.** The mechanical fastening system of any of Claim 1 to Claim 7, wherein at  
10 least a portion of the plurality of the first protrusions extend from the backing material of the male component at an angle substantially perpendicular to the backing material of the male component.
- 9.** The mechanical fastening system of any of Claim 2 to Claim 8, wherein at  
15 least a portion of the plurality of the second protrusions extend from the backing material of the male component at an angle substantially perpendicular to the backing material of the male component.
- 10.** The mechanical fastening system of any of Claim 1 to Claim 9, wherein at  
20 least a portion of the plurality of first protrusions extend from the backing material of the male component at an angle  $\alpha$  of about 15 degrees to about 85 degrees relative to the backing material of the male component.
- 11.** The mechanical fastening system of any of Claim 1 to Claim 10, wherein  
25 the mechanical fastening system is incorporated into an absorbent article.
- 12.** The mechanical fastening system of Claim 11, wherein the absorbent  
article is selected from the group consisting essentially of: a diaper; a training pant; a  
feminine hygiene product; an incontinence product; a wound care product; and, medical  
30 garment.

**13.** The mechanical fastening system of any of Claim 1 to Claim 12, wherein the mechanical fastening system has a peel force during disengagement from about 0.2 N/m to about 50 N/m.

5       **14.** The mechanical fastening system of any of Claim 1 to Claim 13, wherein the mechanical system exhibits a shear force during disengagement from about  $6.08 \times 10^3$  N/m<sup>2</sup> to about  $2.43 \times 10^4$  N/m<sup>2</sup>.

**15.** The mechanical fastening system of any of Claim 2 to Claim 14, wherein at  
10 least a portion of the plurality of the second protrusions have a Flexural Modulus from about 331 MPa to about 2,758 MPa.

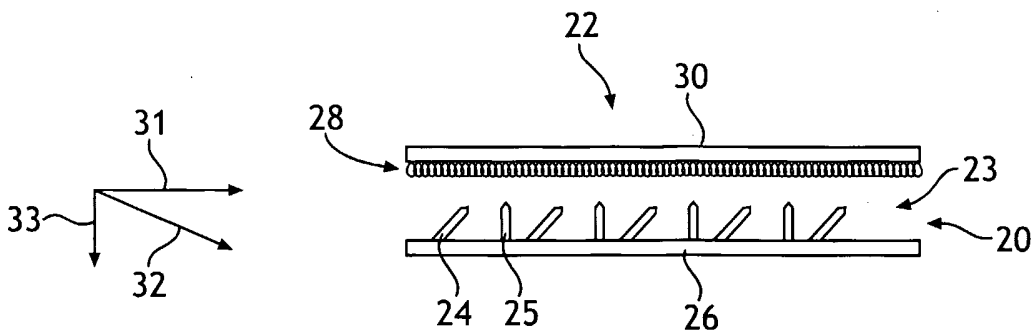

FIG. 1

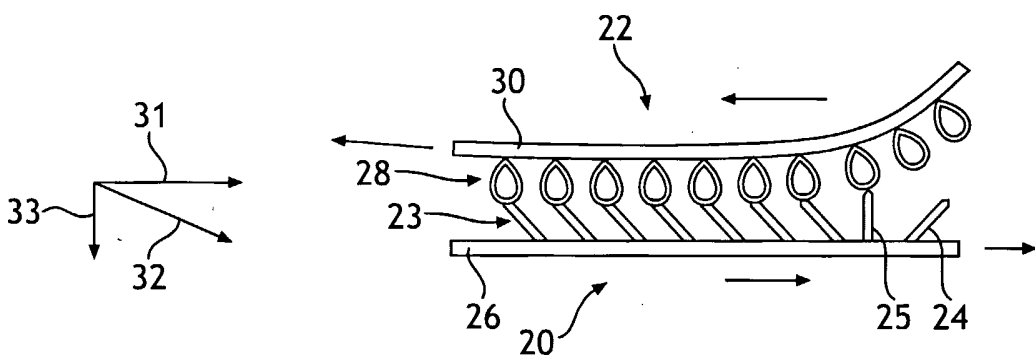

FIG. 2

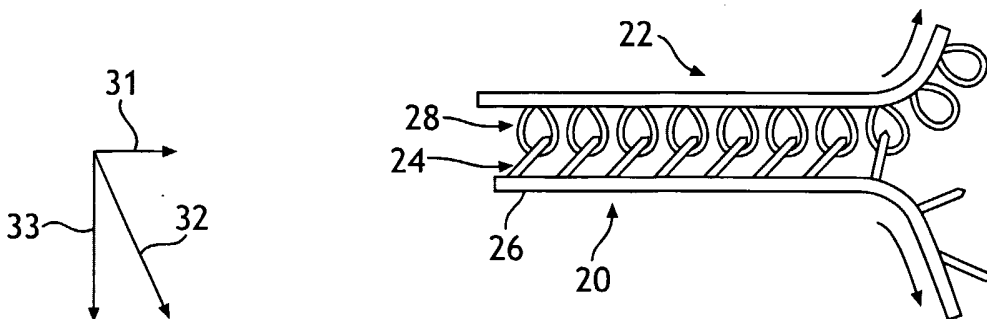

FIG. 2a

2/12

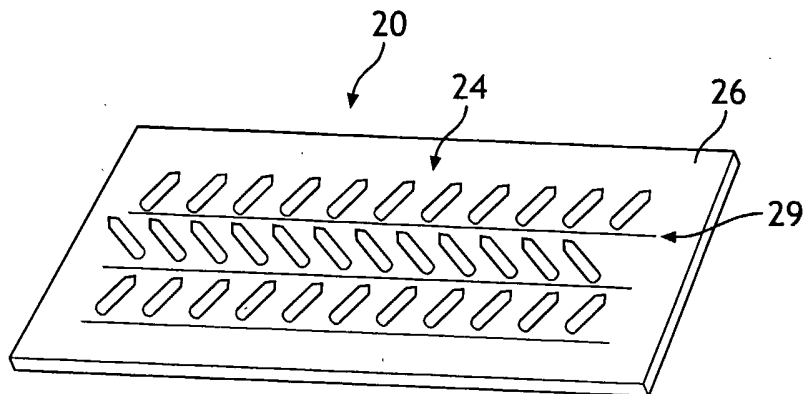

FIG. 3

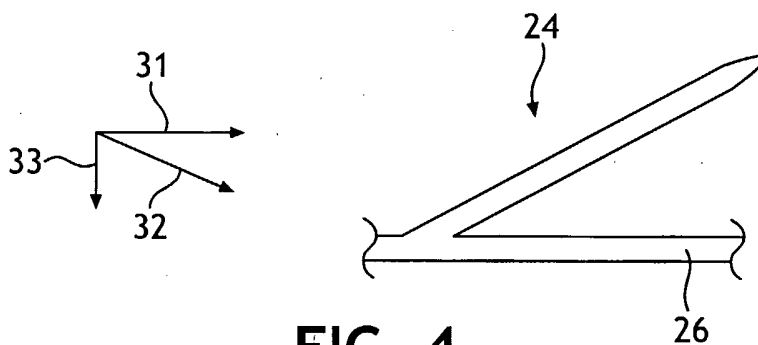

FIG. 4

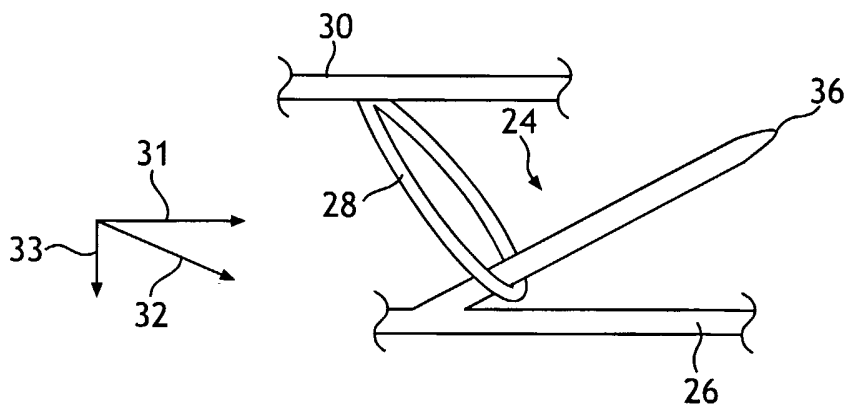
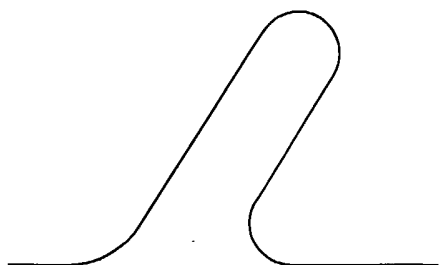
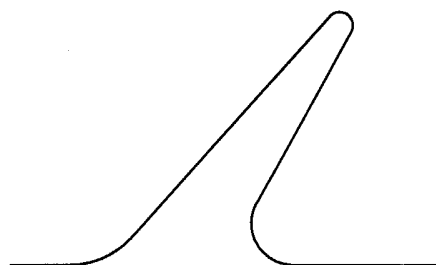

FIG. 5



**FIG. 6a**



**FIG. 6b**

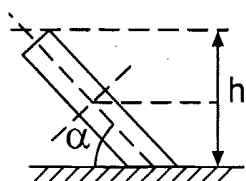

**FIG. 7a**

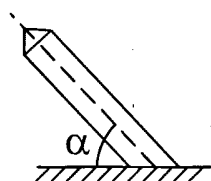

**FIG. 7b**

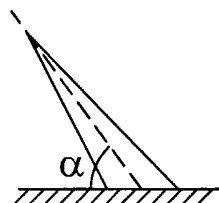

**FIG. 7c**

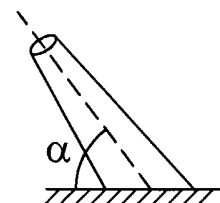

**FIG. 7d**



**FIG. 8a**

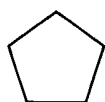

**FIG. 8b**



**FIG. 8c**

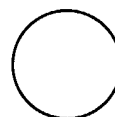

**FIG. 8d**

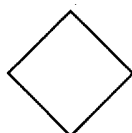

**FIG. 8e**



**FIG. 8f**

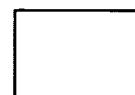

**FIG. 8g**

4/12

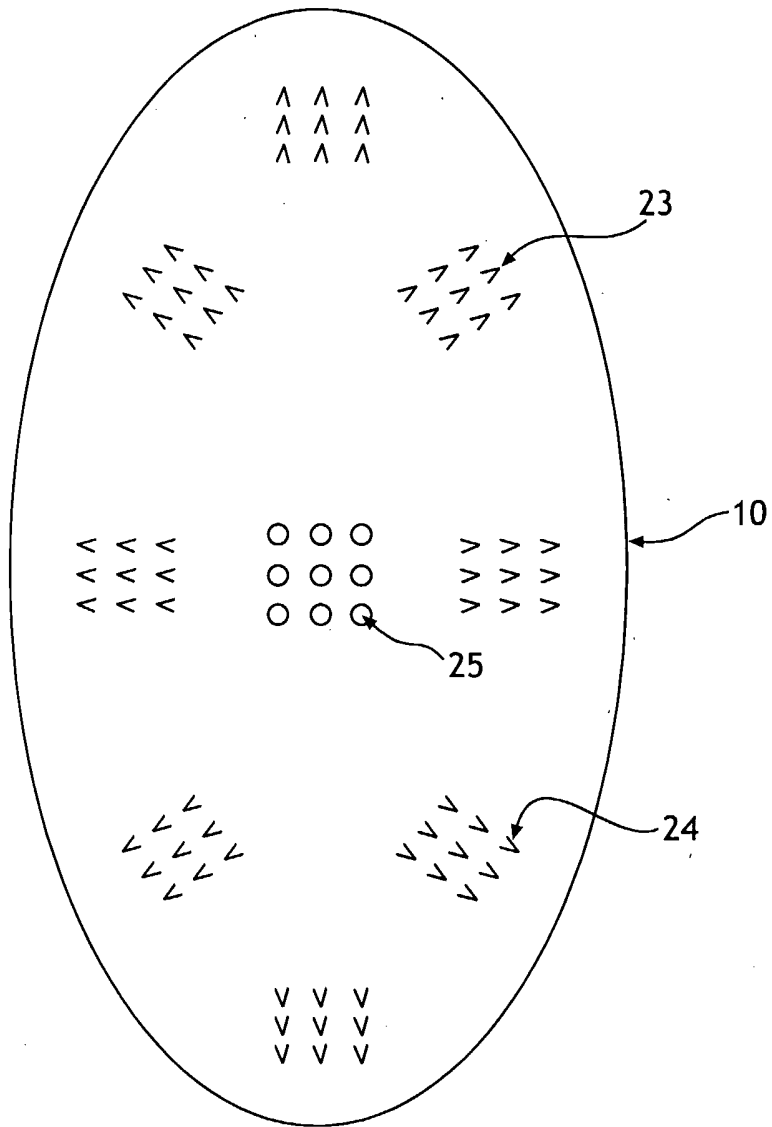

FIG. 9

5/12

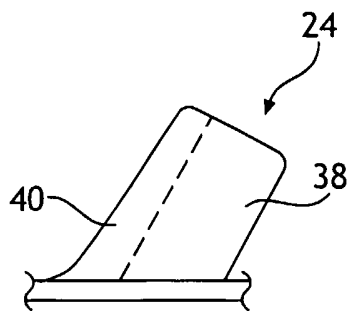

FIG. 10

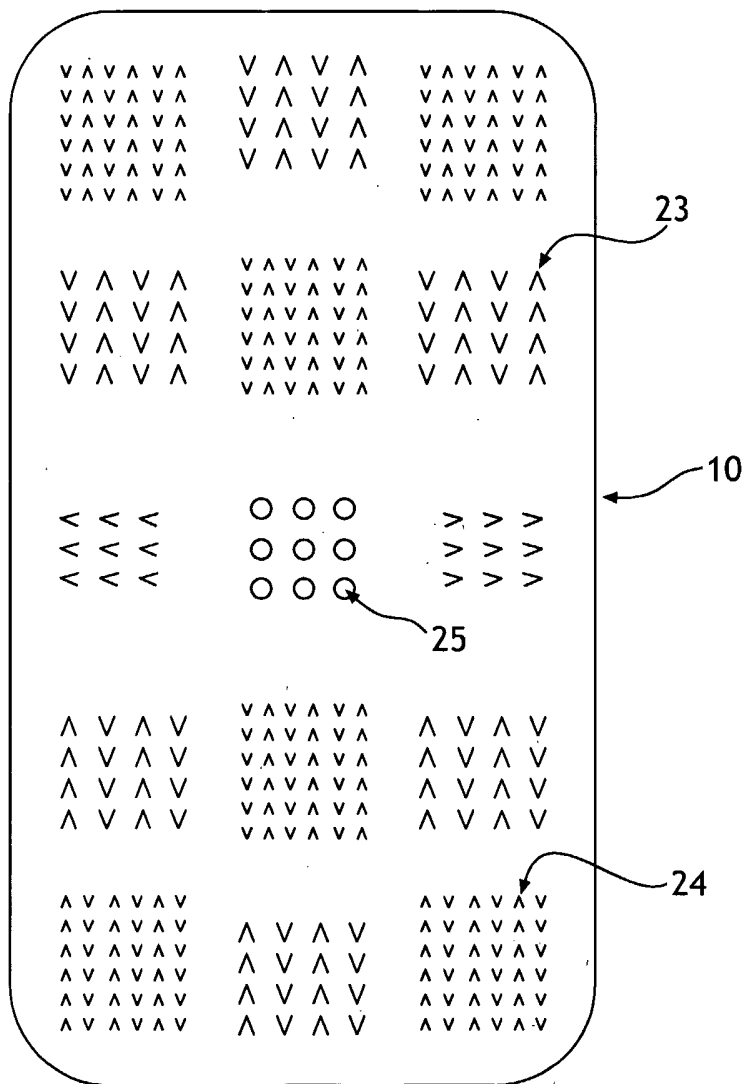

FIG. 11

6/12 )

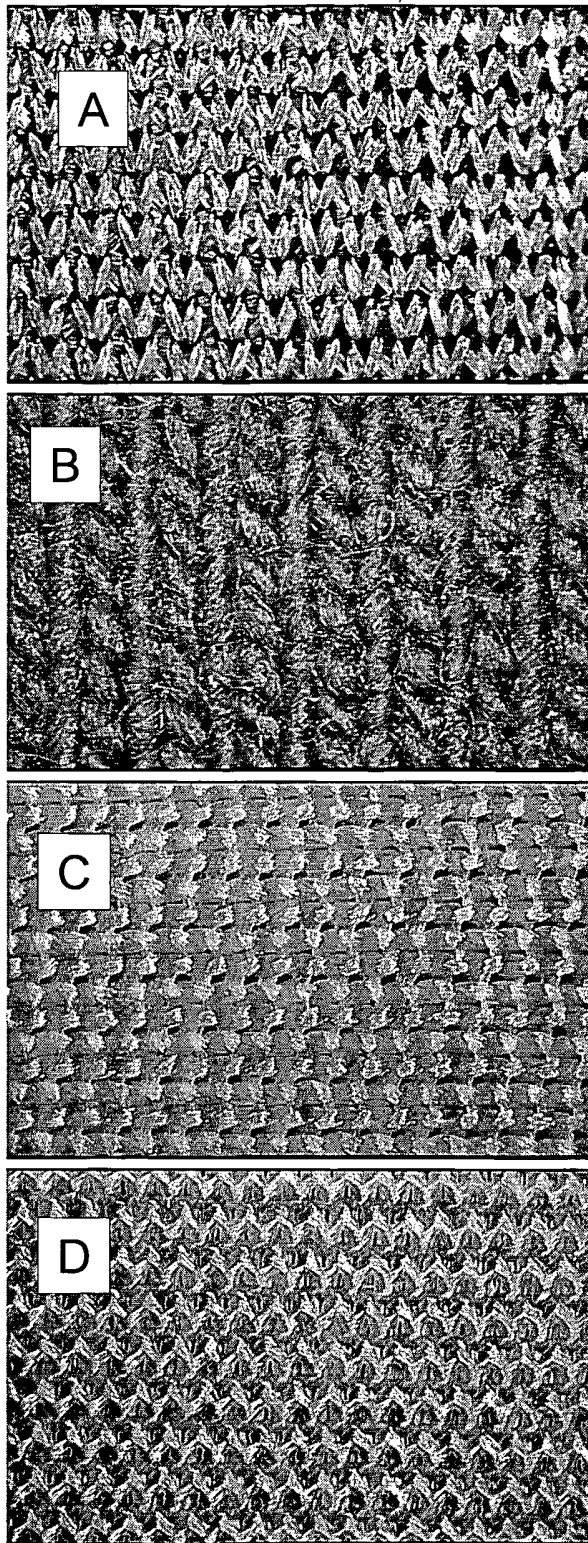
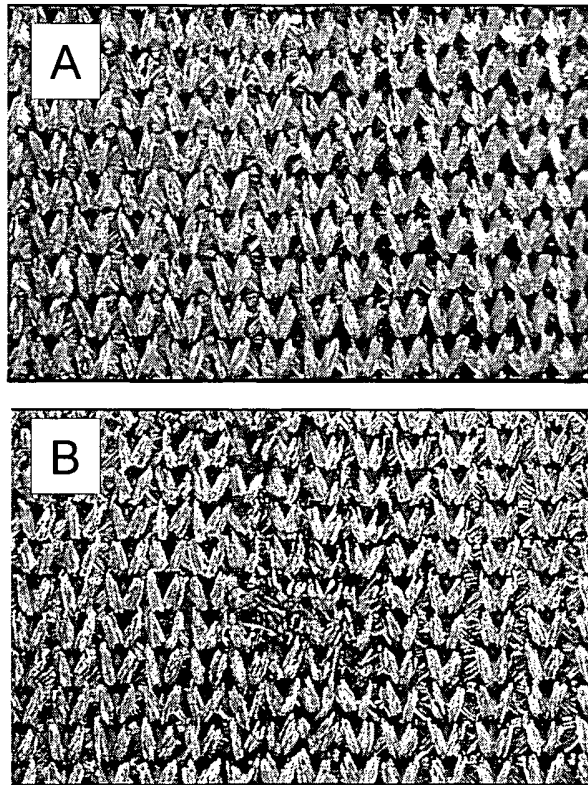

FIG. 12



7/12 )



**FIG. 13**

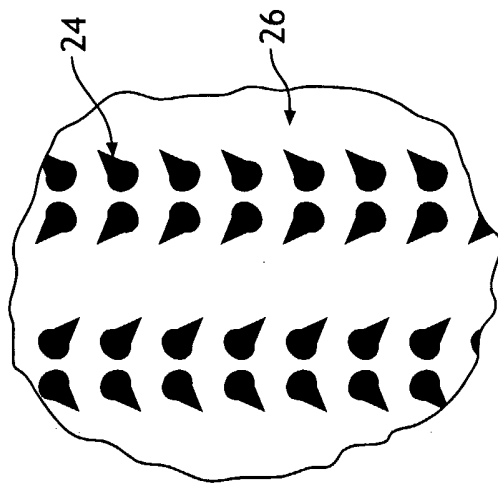

FIG. 14a

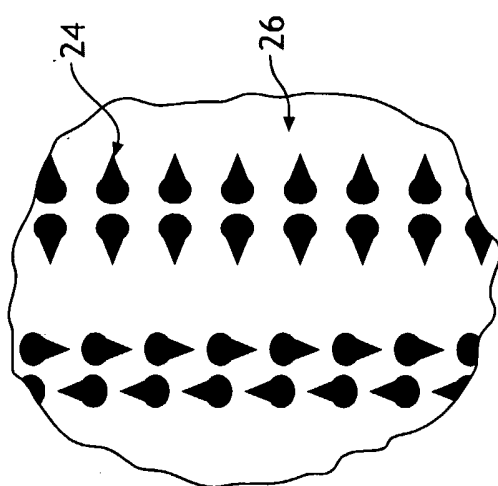

FIG. 14b

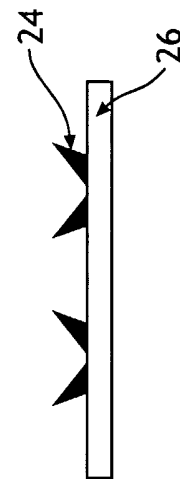

FIG. 14c

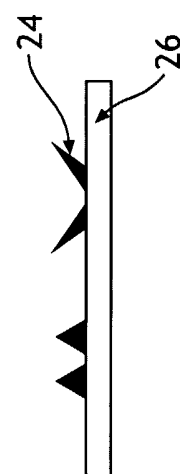

FIG. 14d

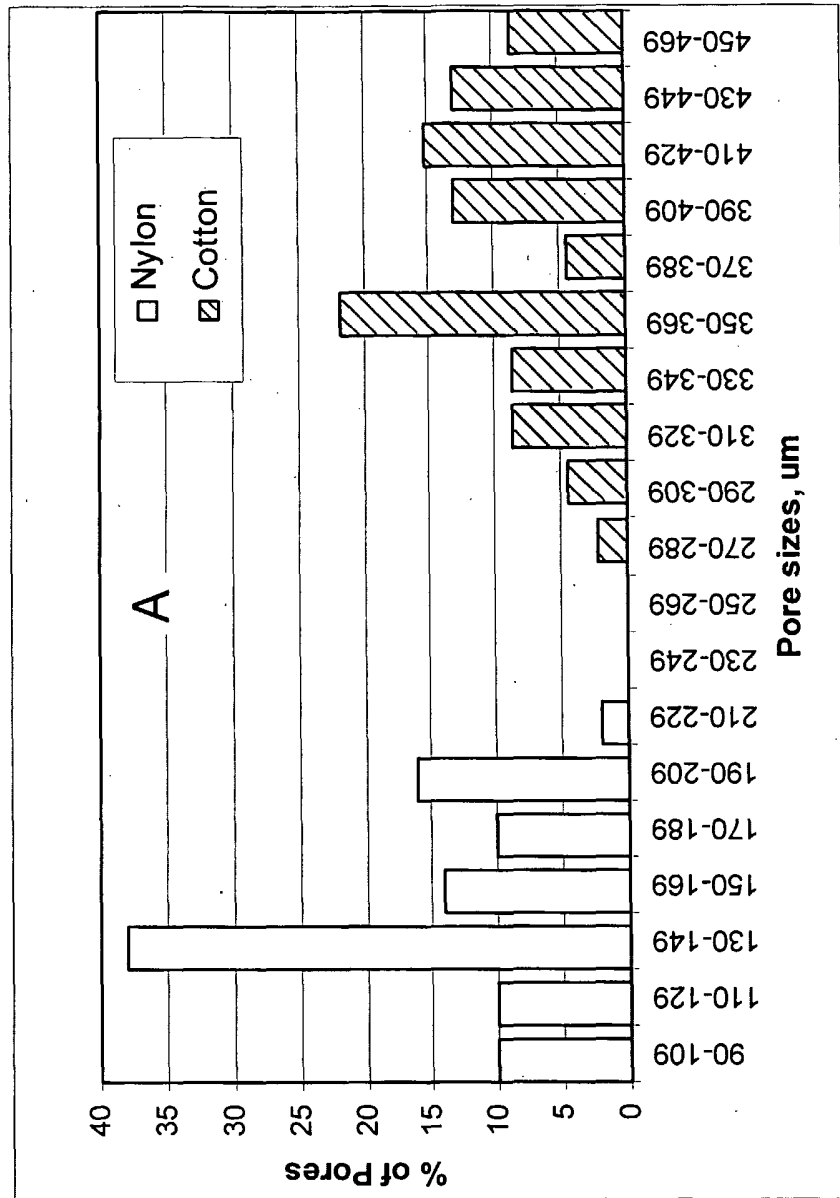
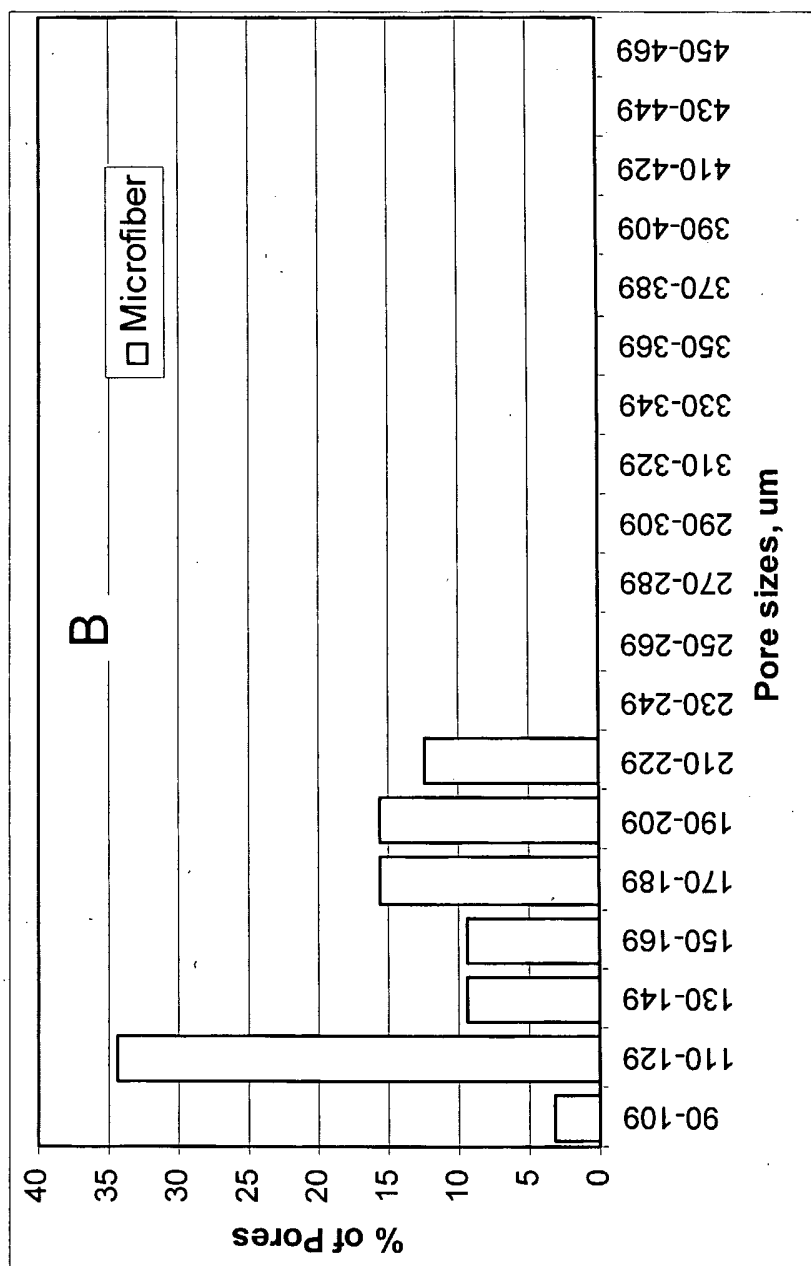

FIG. 15A

10/12



**FIG. 15B**

11/12

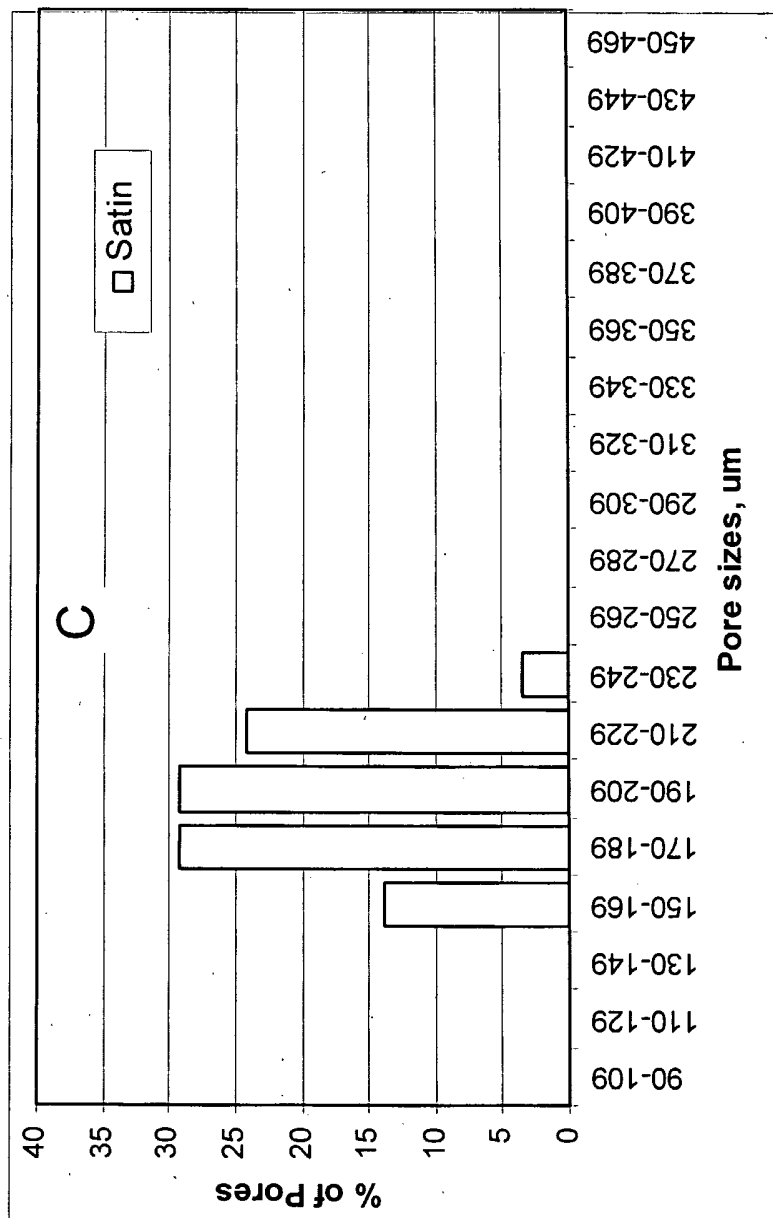
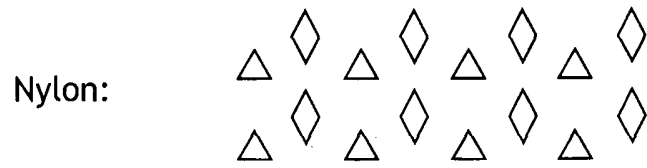
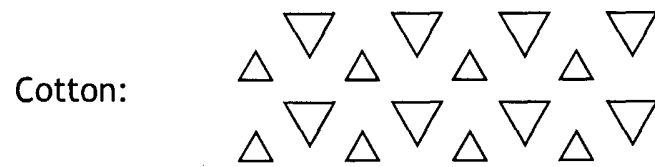

FIG. 15C

12/12 }



**FIG. 16A**



**FIG. 16B**

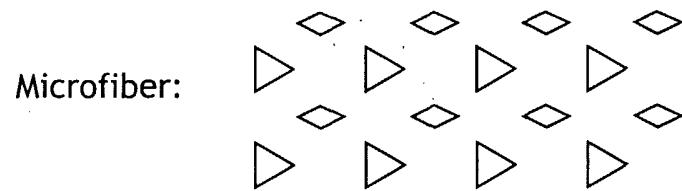

**FIG. 16C**

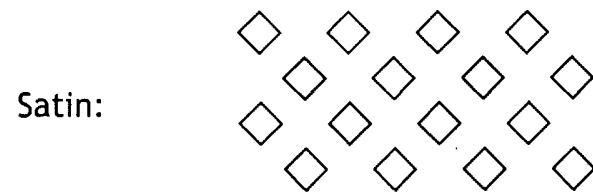

**FIG. 16D**

# INTERNATIONAL SEARCH REPORT

International Application No  
PCT/US2005/005674

**A. CLASSIFICATION OF SUBJECT MATTER**  
IPC 7 A44B18/00

According to International Patent Classification (IPC) or to both national classification and IPC

**B. FIELDS SEARCHED**

Minimum documentation searched (classification system followed by classification symbols)  
IPC 7 A44B

Documentation searched other than minimum documentation to the extent that such documents are included in the fields searched

Electronic data base consulted during the international search (name of data base and, where practical, search terms used)

EPO-Internal, WPI Data, PAJ

**C. DOCUMENTS CONSIDERED TO BE RELEVANT**

Category *	Citation of document, with indication, where appropriate, of the relevant passages	Relevant to claim No.
Y	US 6 588 073 B1 (ZOROMSKI PAULA KAY ET AL) 8 July 2003 (2003-07-08) column 4, line 62 - column 5, line 5; figure 1	1-12
Y	----- US 3 921 259 A (BRUMLIK ET AL) 25 November 1975 (1975-11-25) claim 1	1-12
A	----- US 3 261 069 A (MATHISON ROBERT V) 19 July 1966 (1966-07-19) column 4, line 52 - line 60; figure 9 -----	1-15

Further documents are listed in the continuation of box C.

Patent family members are listed in annex.

\* Special categories of cited documents :

- \*A\* document defining the general state of the art which is not considered to be of particular relevance
- \*E\* earlier document but published on or after the international filing date
- \*L\* document which may throw doubts on priority claim(s) or which is cited to establish the publication date of another citation or other special reason (as specified)
- \*O\* document referring to an oral disclosure, use, exhibition or other means
- \*P\* document published prior to the international filing date but later than the priority date claimed

- \*T\* later document published after the international filing date or priority date and not in conflict with the application but cited to understand the principle or theory underlying the invention
- \*X\* document of particular relevance: the claimed invention cannot be considered novel or cannot be considered to involve an inventive step when the document is taken alone
- \*Y\* document of particular relevance: the claimed invention cannot be considered to involve an inventive step when the document is combined with one or more other such documents, such combination being obvious to a person skilled in the art.
- \*Z\* document member of the same patent family

Date of the actual completion of the international search

6 July 2005

Date of mailing of the international search report

26/07/2005

Name and mailing address of the ISA

European Patent Office, P.B. 5818 Patentlaan 2  
NL - 2280 HV Rijswijk  
Tel. (+31-70) 340-2040, Tx. 31 651 epo nl,  
Fax: (+31-70) 340-3016

Authorized officer

Westermayer, W

# INTERNATIONAL SEARCH REPORT

Information on patent family members

International Application No PCT/US2005/005674
---

Patent document cited in search report	Publication date	Publication date	Patent family member(s)	Publication date
US 6588073	B1	08-07-2003	AU 7353101 A	25-02-2002
			DE 10196503 T0	07-08-2003
			GB 2382103 A ,B	21-05-2003
			GB 2397620 A ,B	28-07-2004
			MX PA03000610 A	14-05-2003
			WO 0214701 A2	21-02-2002
			US 2003192152 A1	16-10-2003
US 3921259	A	25-11-1975	NONE	
US 3261069	A	19-07-1966	FR 1402182 A	11-06-1965
			GB 1061076 A	08-03-1967
			US 3434577 A	25-03-1969