



US 20140110202A1

(19) **United States**  
(12) **Patent Application Publication**  
Vesterby

(10) **Pub. No.: US 2014/0110202 A1**  
(43) **Pub. Date: Apr. 24, 2014**

(54) **APPARATUS FOR CARRYING DRINKS AND ARTICLES ON MOVING LUGGAGE**

(52) **U.S. Cl.**  
CPC ..... *A45C 13/001* (2013.01)  
USPC ..... **190/103**

(71) Applicant: **Mark Vesterby**, Post Falls, ID (US)

(72) Inventor: **Mark Vesterby**, Post Falls, ID (US)

(21) Appl. No.: **14/142,678**

(22) Filed: **Dec. 27, 2013**

**Related U.S. Application Data**

(63) Continuation-in-part of application No. 13/684,426, filed on Nov. 23, 2012, now abandoned.

(60) Provisional application No. 61/563,420, filed on Nov. 23, 2011.

**Publication Classification**

(51) **Int. Cl.**  
*A45C 13/00* (2006.01)

(57) **ABSTRACT**

An apparatus for carrying drinks and articles on moving luggage is provided. In an implementation, a carrying device has an elastic body expandable to fit luggage handles of various widths, and to remain at a selected height on the handle when carrying heavy drinks. Expandable pockets on the elastic body secure cups, bottles, and articles of various sizes. A closed bottom on each expandable pocket secures large and small articles, and for stacking, an expanding taper surface on each closed bottom accommodates the tops of cups, bottles, and articles being held by another instance of the apparatus situated below, to provide a stackable plurality of the carrying devices that are stackable on a single luggage handle for many cups, bottles, and articles of multiple travelers, such as a family.

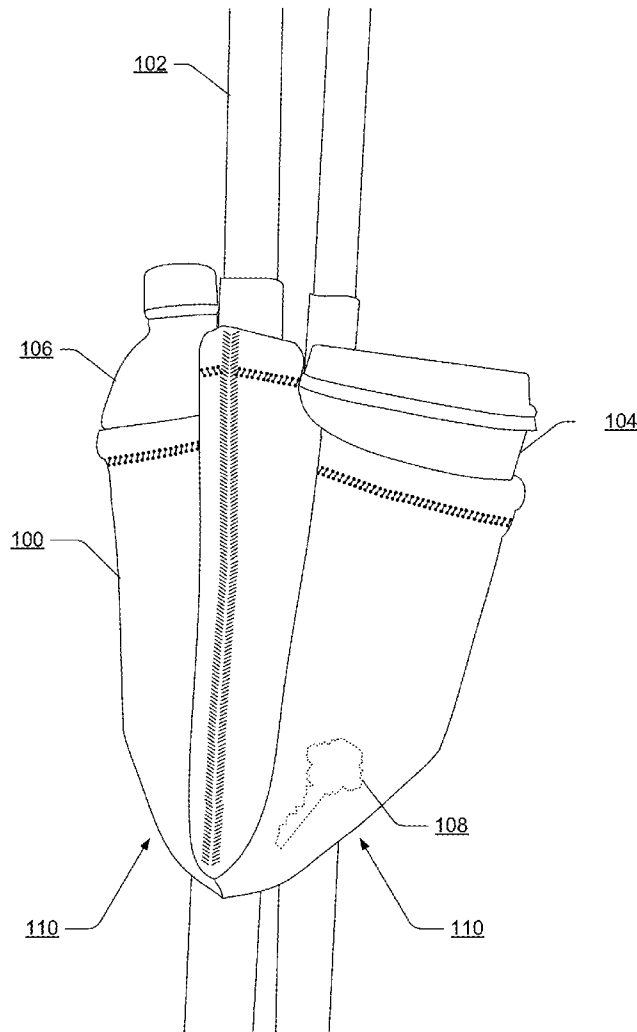

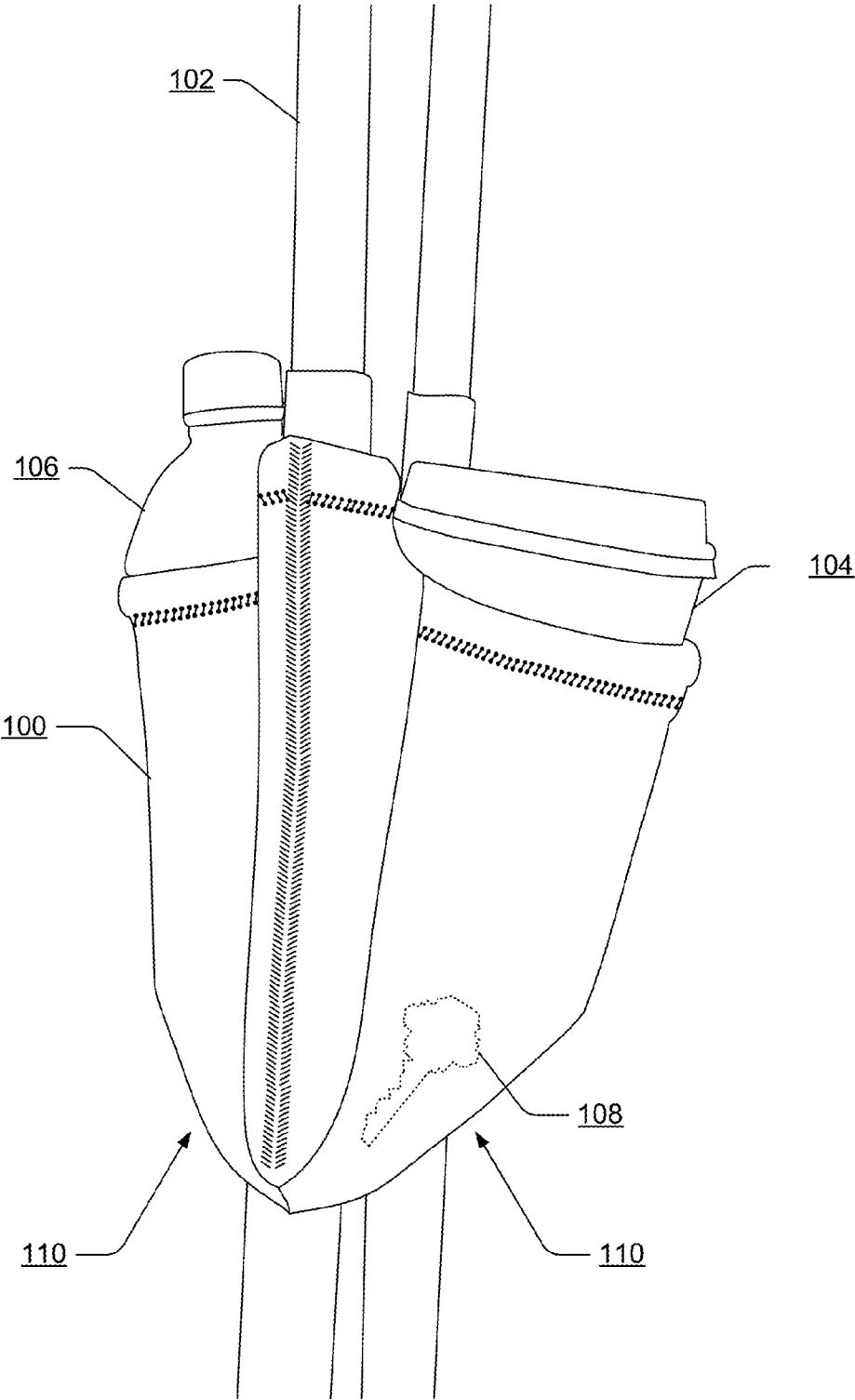

FIG. 1

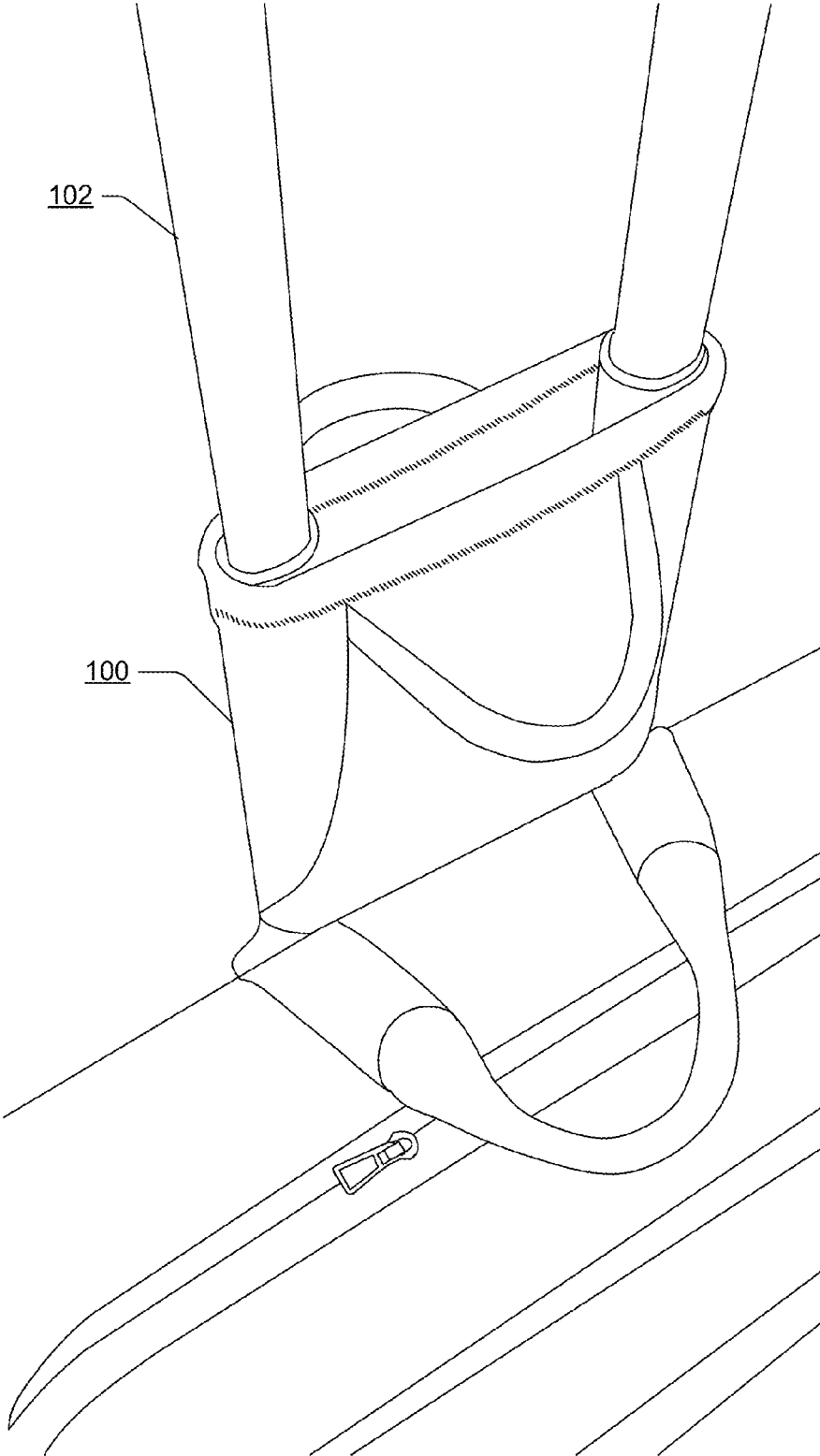

FIG. 2

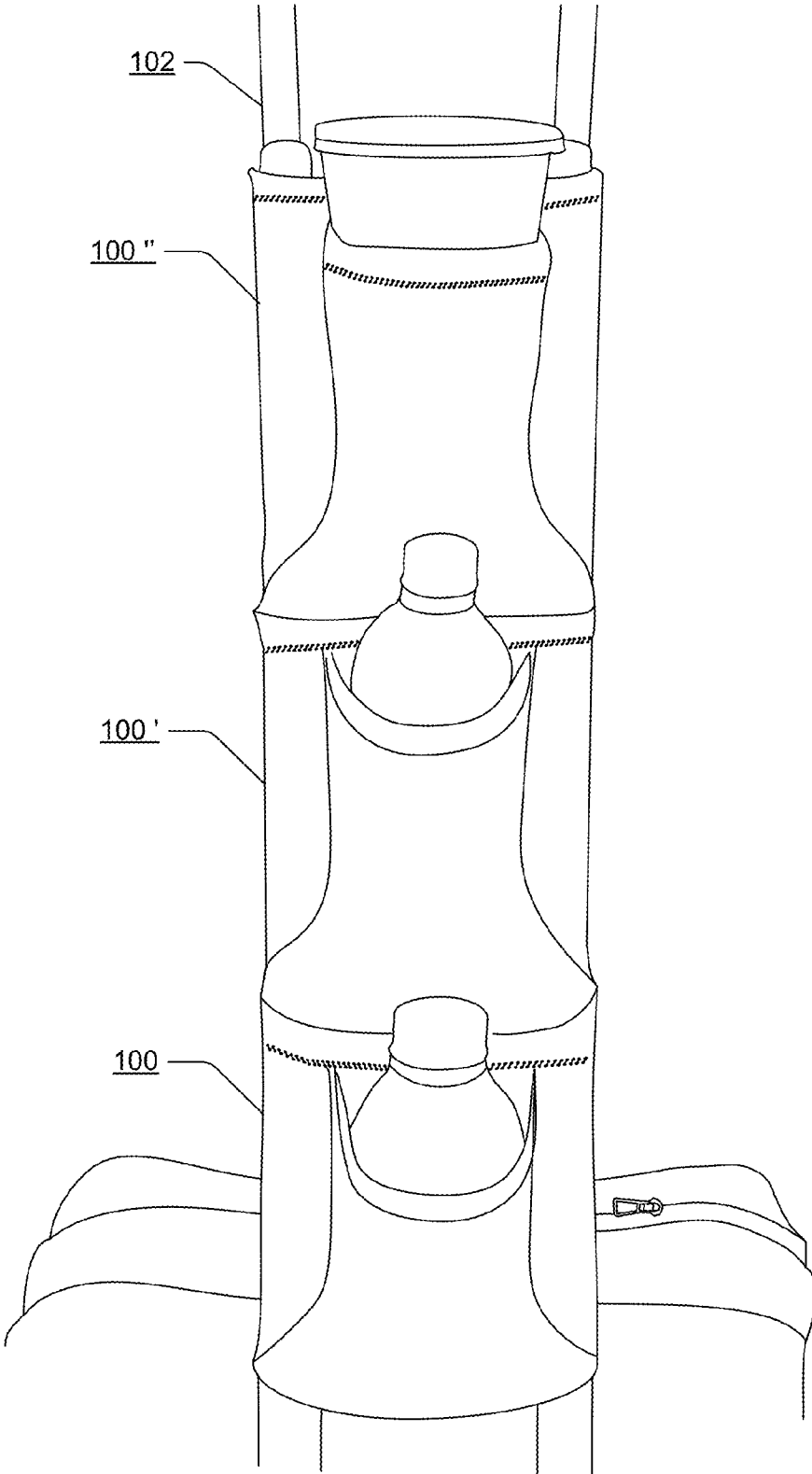

FIG. 3

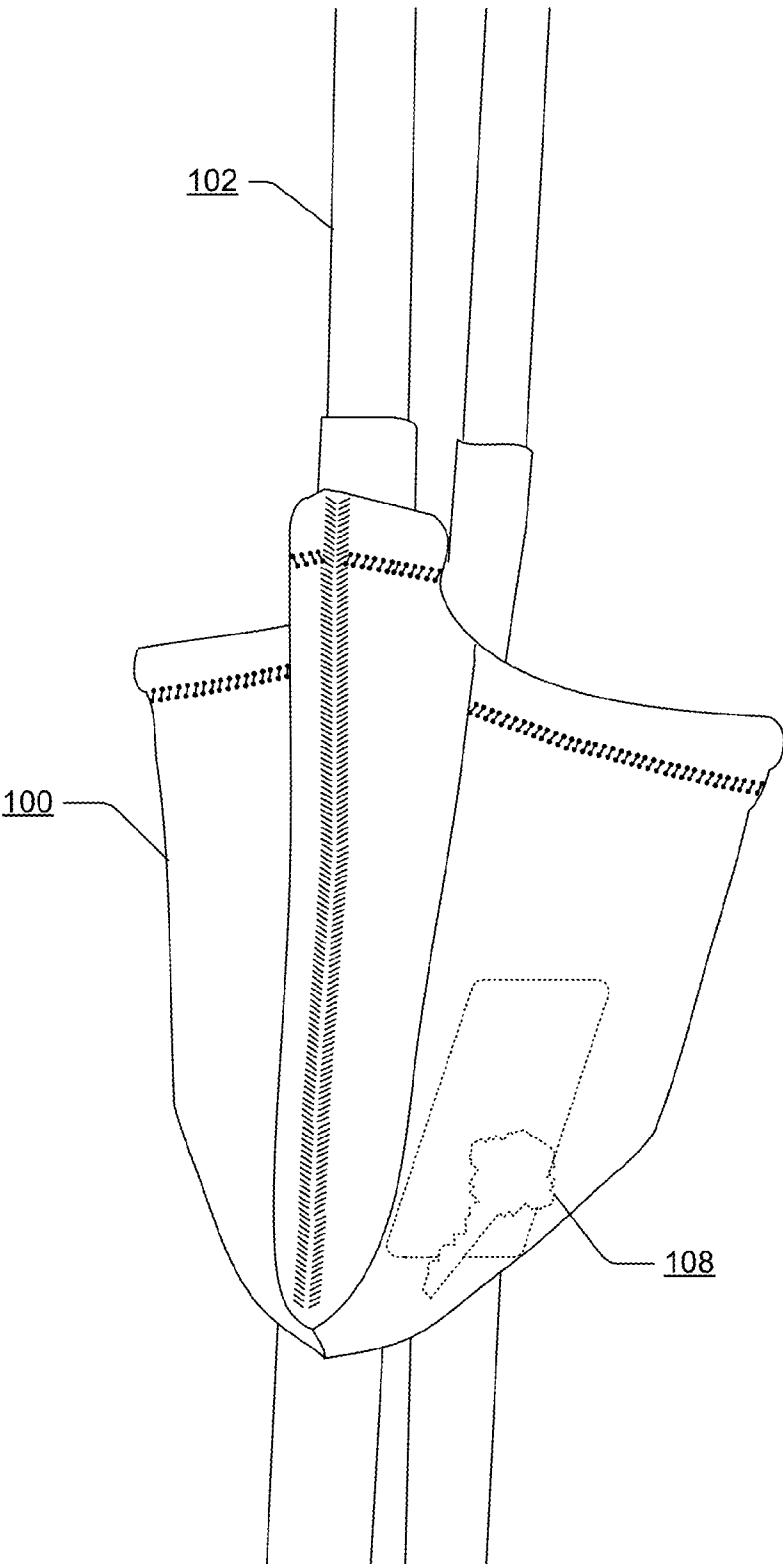

FIG. 4

200

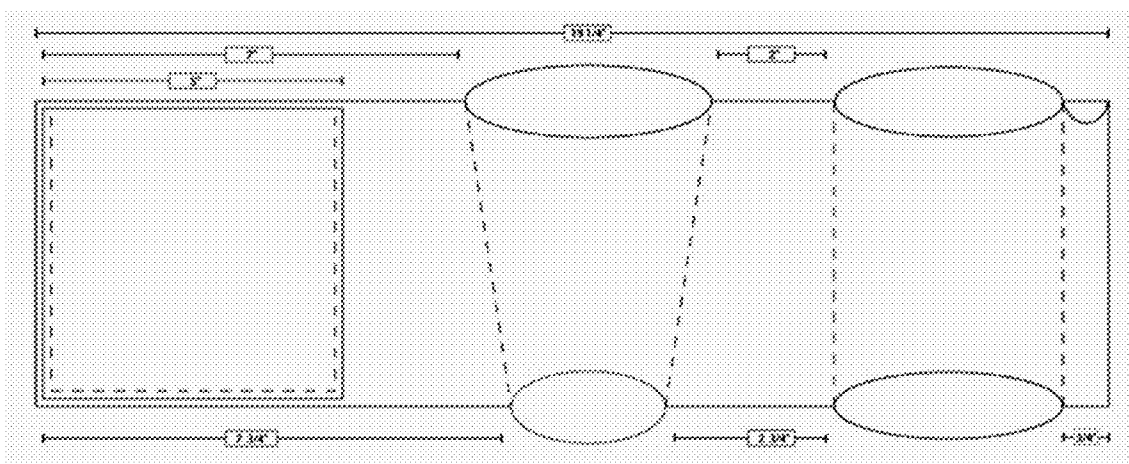

FIG. 5

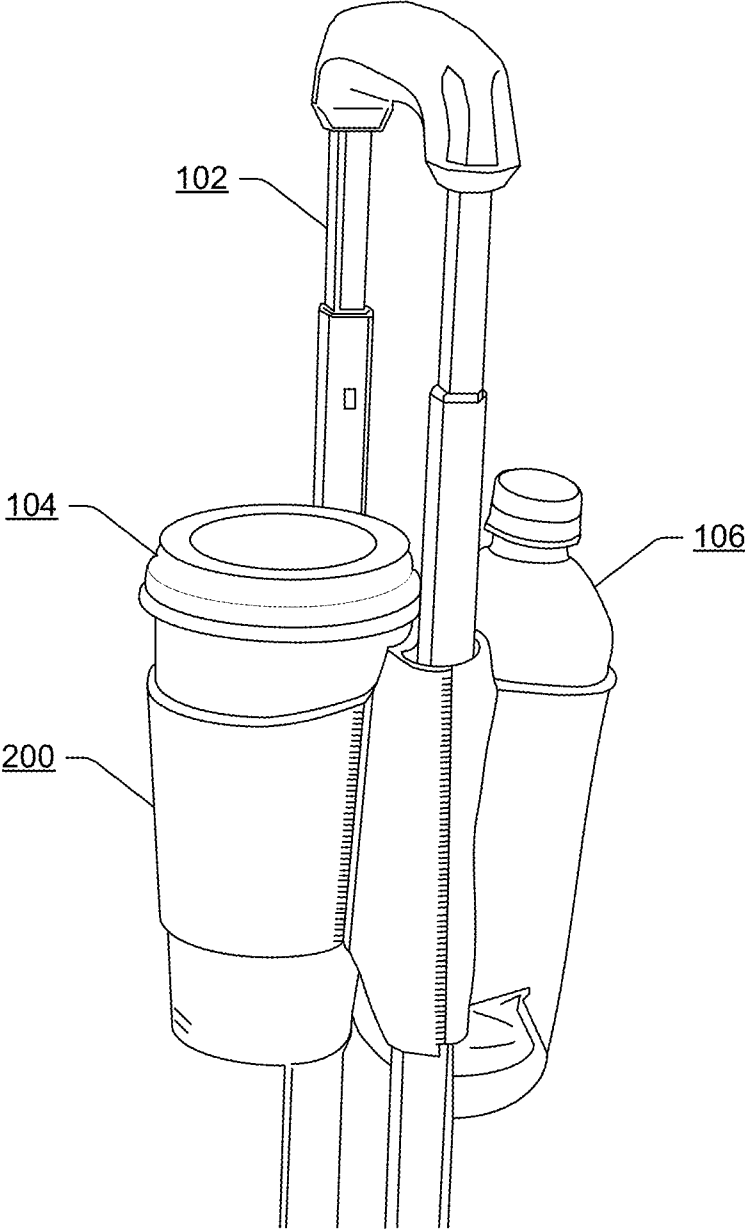

FIG. 6

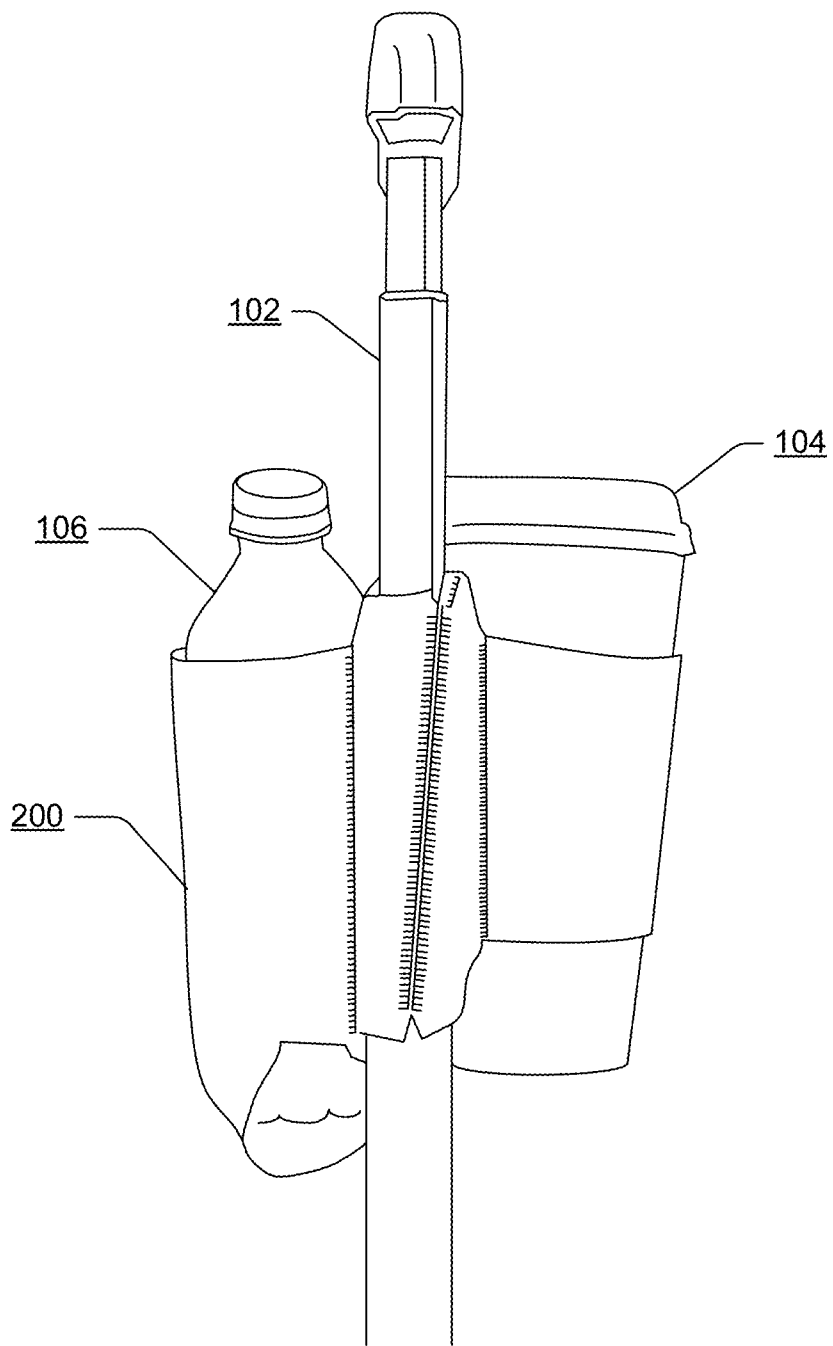

FIG. 7



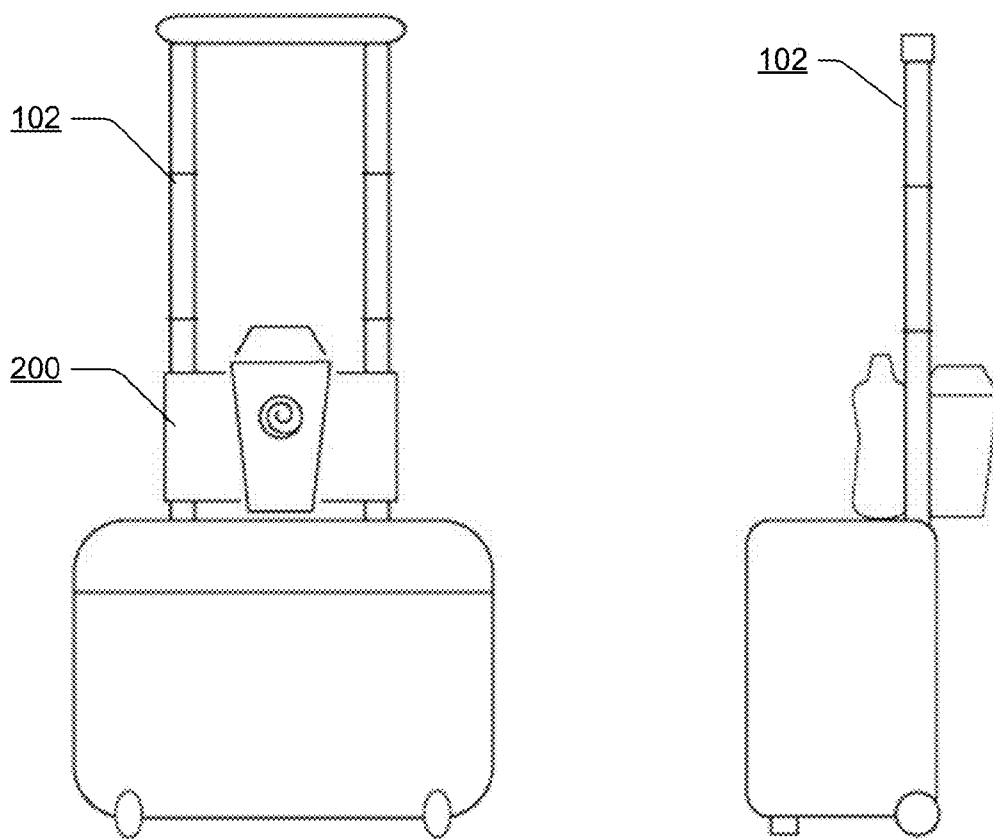

FIG. 8

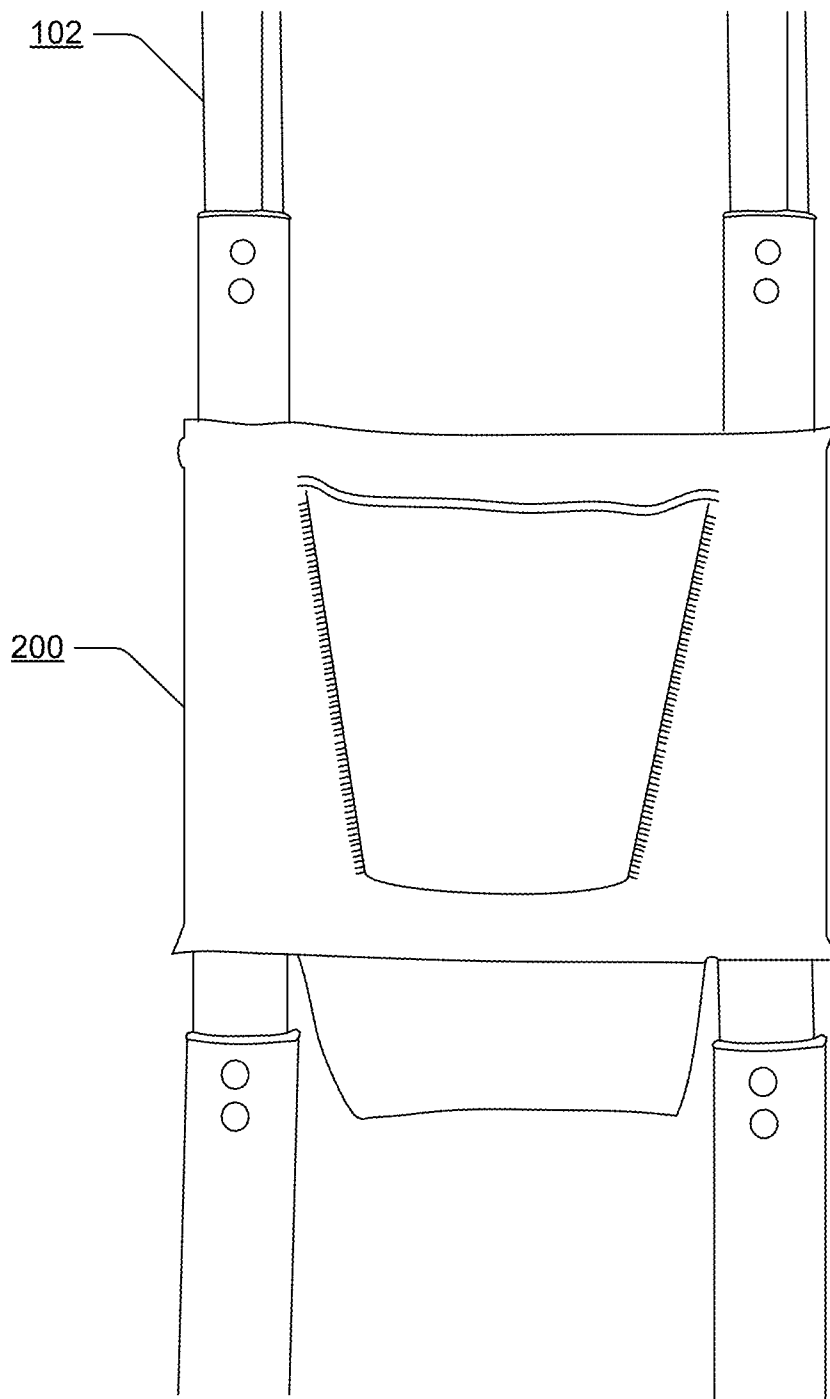

FIG. 9

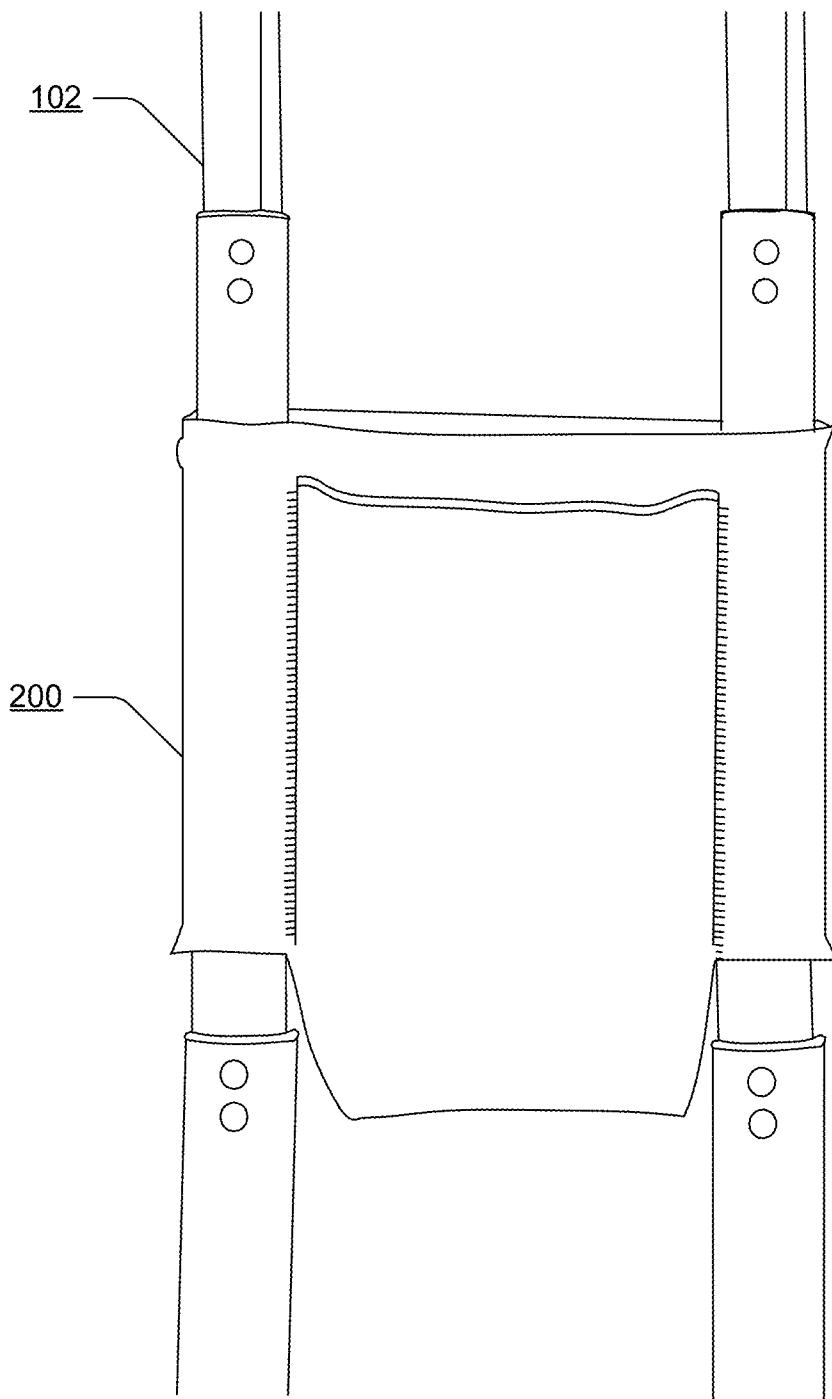

FIG. 10

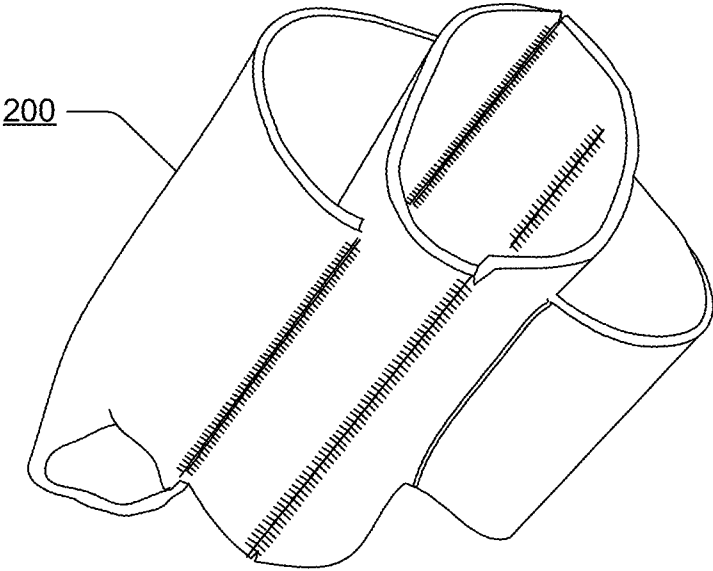

FIG. 11

**APPARATUS FOR CARRYING DRINKS AND ARTICLES ON MOVING LUGGAGE**

**RELATED APPLICATIONS**

[0001] This continuation-in-part application claims the benefit of priority to U.S. patent application Ser. No. 13/684, 426, filed Nov. 23, 2012 and incorporated herein by reference in its entirety, which in turn claims priority to U.S. Provisional Patent Application No. 61/563,420, filed Nov. 23, 2011 and incorporated herein by reference in its entirety.

**BACKGROUND**

[0002] When a traveler or commuter carrying or pulling luggage or a rolling bag and often using a cell phone or mobile device is also carrying hot coffee that needs to be kept from spilling, bottled beverages, and other articles such as personal effects that need to be readily retrievable, such as airplane boarding passes, magazines, and documents, it is often difficult to manage an armload of such articles and also carry or pull the luggage or rolling bag. The problem is greatly compounded when a family travels. It may also be difficult to find a safe and sanitary place in a public transportation facility to set down the beverage or the documents when the items are carried piecemeal. A person carrying many articles has a difficult time freeing a hand for additional tasks, such as transactions or holding a handrail.

**SUMMARY**

[0003] An apparatus for carrying drinks and articles on movable luggage is provided. In an implementation, a carrying device has an elastic body expandable to fit luggage handles of various widths. The elastic body stays at a selected height on the handle without sliding. Expandable pockets on the elastic body secure cups, bottles, and articles of various sizes. A closed bottom on each expandable pocket secures large and small articles from falling out. Multiple instances of the carrying device are stackable on a handle to accommodate the drinks of several people or a family. To stack, an expanding taper surface on each closed bottom accommodates the tops of cups, bottles, and articles being held by another instance of the apparatus below, in order to provide a stackable plurality of the carrying devices that are stackable on a single luggage handle for the many cups, bottles, and articles of multiple travelers, such as a family.

**BRIEF DESCRIPTION OF THE DRAWINGS**

[0004] FIG. 1 is a diagram of a first example carrying device attached to a handle of rolling luggage.  
[0005] FIG. 2 is an elevation view of the first example carrying device attached to a handle of rolling luggage.  
[0006] FIG. 3 is a diagram of three of the first example carrying devices attached to a handle of rolling luggage, and stacked vertically on the handle.  
[0007] FIG. 4 is a diagram of the first example carrying device attached to the handle of a piece of rolling luggage at a selected height, and securing personal effects such as keys, cards, phone, documents, boarding passes, and mobile computing devices.  
[0008] FIG. 5 is a diagram of an example construction layout of a second example carrying device.  
[0009] FIG. 6 is a diagram of the second example carrying device, attached to the handle of a piece of luggage, and securing a lidded coffee cup and a bottle for liquids.

[0010] FIG. 7 is a side-view diagram of the second example carrying device in FIG. 6.

[0011] FIG. 8 is a diagram of the second example carrying device attached low on the handle of an example piece of rolling luggage.

[0012] FIG. 9 is a diagram of example pocket construction on a first side of a second example carrying device.

[0013] FIG. 10 is a diagram of example pocket construction on a second side the second example carrying device shown in FIG. 9.

[0014] FIG. 11 is a diagram of example construction of the second example carrying device.

**DETAILED DESCRIPTION**

[0015] This disclosure describes apparatuses for carrying drinks and articles on moving luggage. The apparatuses for carrying, as shown in FIGS. 1-11, are referred to herein as example carrying devices, and can attach to luggage, to luggage handles 102, as well as to bags, buckets, equipment, and other objects in order to carry a user's cups 104, bottles 106, and other articles 108, such as personal effects and containers, sub sandwiches, wraps, other food items papers, cards, tablets, boarding pass, driver's license, cell phone, business cards, newspaper, magazines, tables, electronic devices, and so forth, in order to keep these items secure and to free the user's hands. For example, a traveler at an airport or subway may have an armload of loose personal or family items, such as a cup 104 of coffee, food, a cell phone, a boarding pass, magazines, a baby bottle, etc. The example carrying device 100 attaches to a piece of luggage or to other objects at hand and secures the various loose items for the user at a selected height.

[0016] FIG. 1 shows a first example carrying device 100 attached to a handle 102 of rolling luggage at a selected height. In this example, a first pocket and a second pocket can hold a combination of coffee cups 104, bottles 106 for liquids, and other articles 108. In an implementation, each example carrying device 100 has pockets that are open at the top and closed at the bottom. The closed-bottom pockets allow each pocket to hold small articles 108, without the articles 108 falling through the pocket.

[0017] The elastic body of the carrying device 100, once placed at a selected height on the luggage handle 102, does not slide down even when holding heavy drinks and the like. The carrying device 100 can be moved up and down the handle 102 to a desired location and remains in that location without sliding down from the weight of drinks being carried. This allows the user to move the carrying device 100 up the handle 102 so that the user can stack another bag, such as a brief case or another carry-on, on top of their existing rolling luggage. The selectable height also makes it more convenient to reach the beverage when standing and waiting to board an airplane, for example.

[0018] In an implementation, for stackability, the pockets of the example carrying device 100 form a bottom taper 110 when a cup 104 or bottle 106 is inserted, in order for multiple instances of the carrying device 100 to be stackable on a handle 102 (FIG. 3). The pockets may hold a cup 104, bottle 106, or other article 108 at a slight angle from the vertical, in order to allow the bottom tapers 110 of a carrying device 100 above to fit snugly against an instance of the carrying device 100 below (FIG. 3). In an implementation, when the pockets are empty, the example carrying device 100 may lay flatter

against a handle **102** or surface with the pockets collapsed or retracted, or able to be collapsed when an object pushes against them.

**[0019]** FIG. 2 shows an example carrying device **100** attached to a luggage handle **102** with pockets empty, but in an implementation in which the pocket openings stay accessible to receive a drink. In an implementation, each carrying device **100** allows the traveler or other user to place at least one lidded beverage container, such as a lidded coffee or tea cup **104** and/or at least one capped beverage container, such as bottled water **106** or soda, into the device. The example carrying device **100** prevents spills caused by other travelers kicking the beverage or from the beverage falling over, from lack of balance, on a seat cushion.

**[0020]** In an implementation, the example carrying device **100** may include a convenience pocket that also provides a safe and sanitary place to set a mobile device, which can be used in transit or while charging the device at a gate or other location. Such a convenience pocket can also be used for quick and easy storage and access to a boarding pass, driver's license, passport, business cards and other items.

**[0021]** FIG. 3 shows example carrying devices **100**, **100'**, and **100''** stacked on a luggage handle **102** to secure cups **104**, bottles **106**, and articles **108** of a family, for example. The pockets of each example carrying device **100** form a taper **110** when a cup **104** or bottle **106** is inserted, in order for multiple instances of the carrying device **100** to be stackable on the handle **102**. The pockets may hold a cup **104**, bottle **106**, or other article **108** at a slight angle from the vertical, in order to allow the tops of the cups **104** and bottles to avoid the bottom tapers **110** of a carrying device **100'** above, and for the carrying device **100'** above to fit snugly against an instance of the carrying device **100** below.

**[0022]** In an implementation, each carrying device **100** for carrying drinks on a handle of moving luggage has an elastic body expandable to fit luggage handles of various widths, expandable pockets on the elastic body to secure cups, bottles, and articles of various sizes, a closed bottom on each expandable pocket to secure small articles, and an expanding taper surface on each closed bottom to accommodate the tops of cups, bottles, and articles being held by another instance of the carrying device **100** below to provide a stackable plurality of the carrying devices **100** & **100'** & **100''** stackable on a single luggage handle.

**[0023]** Multiple instances of the carrying device **100** stacked vertically on a luggage handle each snugly touch an adjacent instance of the carrying device **100**, even when each pocket of each instance of the carrying device **100** secures a cup, a bottle, or an article.

**[0024]** The carrying device **100** can be made so that each pocket collapses flat when each pocket is empty, or can be made so that each pocket remains open at a top of the pocket when the pocket is empty.

**[0025]** FIG. 4 shows the example carrying device **100** carrying articles **108** such as credit cards and the like.

#### Other Example Designs

**[0026]** FIGS. 5-11 show a second example carrying device **200**, with open-bottom pockets. The second example carrying device **200** may include one or more article holders each made of a band of material to form a ring against the flexible belt. Each band may be sized to hold a cup, a tool, an instru-

ment, etc. In one implementation, one or more of the article bands may be adjustable to hold different sizes of different articles at various times.

**[0027]** Whereas the article bands just described form a ring of material with an open top and open bottom, the article holders may be pockets, with a closed bottom. In an implementation, the band or the pockets are tapered so that the top opening of the band or pocket is larger than the bottom of the pocket or the bottom opening of the band. These tapered bands or pockets allow the holder to secure a tapered or a conical object, such as a tapered paper cup, a tapered tool, or even a tapered ice cream cone.

**[0028]** In an implementation, the second example carrying device **200** also includes one or more convenient small narrow pockets that can be used for beverage splash sticks, sugar packets, straws, pens, and so forth.

**[0029]** The second example carrying device **200** can be wrapped, strapped, or in other ways attached onto the extending handle **102** of a roller bag or other luggage item to hold a beverage or other item and to render the beverage or other item readily available. When not in use, the second example carrying device **200** can then be tucked away in the user's pocket or a pocket of the luggage. By reducing the handle **102** of the roller bag or rolling suitcase down to a short length, e.g., down to slightly above the carrying device **100**, the user can maintain the bag in a relatively upright position in order to maintaining the liquid surface of the beverage in a safe horizontal position. Using the second example carrying device **200** in this manner is safer and more convenient for the user than holding the lidded beverage in a separate hand while carrying the often-heavy bag in the other arm, particularly when navigating tight spaces such as rows and the aisles of busses, trains, taxis, and airplanes. Moreover, when the second example carrying device **200** is attached to the piece of luggage, and one or more beverages and/or documents are stored in or on the carrying device **100**, the user may manage all of these various items by simply holding the luggage handle **102**. This allows the user to free the other hand for holding a handrail or other steadying object, such as airplane seat, to provide support and safety as the traveler moves about the cabin of a train or airplane, or when ducking into a taxi. The traveler may then transfer the beverage to a safe location, such as to a cup holder or the back pocket of a seat. Then the traveler may place the second example carrying device **200** in a pocket on their bag or luggage, and stow the carrying device **100** away for travel.

**[0030]** Alternatively, the example apparatus may be transferred to a conventional seat back tray in an upright position, such as those conventionally found on airplanes and trains, thus allowing the user to further access the carrying device **100** and the items therein or thereon during seated travel.

**[0031]** In an implementation, the second example carrying device **200** assists parents and guardians traveling with children to carry baby bottles and beverages for their children in a safe and sanitary location. Because the apparatus may be secured at a low location that a toddler or older child can reach, the carrying device **100** allows the parent to leave the child's beverage, such as a soda, in the holder for the child to drink from rather than requiring the child to carry the beverage through the airport or gate with risk of dropping or spilling the beverage.

**[0032]** The second example carrying device **200** may be constructed out of elastic, stretchy, rubberized materials or other suitable fabric or material. A securing mechanism, such

as hook and loop fasteners may enable a custom fit to a variety of bag handles **102** or to other articles. Because the second example carrying device **200** may be comprised of a soft and stretchy material, the traveler can rest assured that it will not scratch or mar the handle **102** of their bag. The material may also operate as an insulator that helps keep hot drinks hot and cold drinks cold for extended periods of time. Example carrying devices **100** can be made out of such materials as: elastomeric, elasticized fabric, spandex, elastane (e.g., LYCRA), neoprene, cotton, felt, canvas, leather, flannel, velvet, nylon, silk, rubber, and so forth.

**[0033]** In an implementation, the second example carrying device **200** can be customized with various pockets for a multitude of personal items. The second example carrying device **200** may also be customized to attach to various other articles, such as other types of handles **102** or objects: strollers, golf carts, tools, tool boxes, buckets, ladders, bicycles, shopping carts, chairs, tables, bookshelves, various types of furniture, exercise equipment, and so forth.

**[0034]** In one example configuration, the second example carrying device **200** may be transferred and worn on a person's arm. Or, an extension belt or band can be attached to the carrying device **100** to secure the carrying device **100** around a person's waist. This enables the carrying device **100** to assist when the user boards an airplane, train, or shuttle without the carrying device **100** being attached to a luggage handle **102**.

**[0035]** The second example carrying device **200** may be printed or embroidered with a logo, message, or other advertising to be used as a promotional product for companies, tradeshow, events, and marketing.

**[0036]** In an alternative implementation, the second example carrying device **200** holds a cordless drill and other tools, providing an advantage on a ladder or other structure. The second example carrying device **200** may also be strapped around the legs of a ladder, or around studs or pipes encountered while framing or working around a building. In an implementation, the second example carrying device **200** serves as a neoprene tool belt that releasably secures to the user's waist or a ladder, allowing the user to control where and how the tools are stored and accessed.

1. An apparatus for carrying drinks on a handle of moving luggage, comprising:
  - an elastic body expandable to fit luggage handles of various widths and to remain at a selected height on a luggage handle when carrying heavy drinks;
  - expandable pockets on the elastic body to secure cups, bottles, and articles of various sizes;
  - a closed bottom on each expandable pocket to secure large and small articles from falling through the expandable pocket;
  - an expanding taper surface on each closed bottom to accommodate the tops of cups, bottles, and articles being held by another instance of the apparatus below to provide a stackable plurality of the apparatuses stackable on a single luggage handle.
2. The apparatus of claim **1**, wherein multiple instances of the apparatus stacked vertically on a luggage handle each snugly touch an adjacent instance of the apparatus when each pocket of each instance of the apparatus secures a cup, a bottle, or an article.
3. The apparatus of claim **1**, wherein each pocket collapses flat when each pocket is empty.

4. The apparatus of claim **1**, wherein each pocket remains open at a top of the pocket when the pocket is empty.

5. The apparatus of claim **1**, wherein the elastic body can be moved by a user up and down the luggage handle to a selected height when the apparatus is carrying heavy drinks, and remains at the selected height when carrying the heavy drinks.

6. The apparatus of claim **1**, wherein the apparatus folds and reduces when removed from the luggage handle for compact stowing away in a luggage pocket or a user's clothing pocket.

7. An apparatus, comprising:

- a flexible band for attaching around a handle of a piece of luggage, the flexible band remaining at a selected height on the handle when carrying a heavy drink;
- at least one drink holder attached to the flexible band; and
- wherein the apparatus folds when removed from the handle for storage in a user's clothing pocket.

8. The apparatus of claim **7**, wherein the flexible band has a width dimension sufficient to secure the flexible band to an article such that a container held by the holder remains substantially upright.

9. The apparatus of claim **8**, wherein the holder secures a container for liquid such that a surface of the liquid remains horizontal.

10. The apparatus of claim **9**, wherein a fastener allows the flexible band to be adjusted to attach to a larger object or to attach around a user's waist.

11. The apparatus of claim **10**, wherein the fastener comprises one of a set of hook and loop fasteners, a snap, a button, a zipper, a hook, a clasp, an adhesive, a lace, straps, or a buckle.

12. The apparatus of claim **10**, wherein the flexible band and the fastener enable the apparatus to attach to a handle, a suitcase, a piece of luggage, a carrying bag, a handle of a rolling container, a user's waist, a user's midsection, a user's leg, a user's arm, a bicycle, a bag, a tool box, a cooler, a liquid dispenser, a beer keg, a box, a lifting dolly, a briefcase, a bucket, a ladder, a lawnmower, a wagon, a tractor, a golf bag, a golf cart, a boat, a motorcycle, a work table, a computer box, a post, a pillar, a fence, a shopping cart, legs of a folding table, backrest of a folding chair, or support members of a ladder.

13. The apparatus of claim **7**, wherein the flexible band is constructed of a flexible material, the flexible material selected from the group of flexible materials consisting of an elastomeric, an elasticized fabric, spandex, an elastane, LYCRA, nylon, neoprene, cotton, felt, flannel, velvet, silk, canvas, leather, and rubber.

14. The apparatus of claim **7**, wherein the holder comprises a band of material, each end of the band of material attached to the flexible band.

15. The apparatus of claim **7**, wherein the holder comprises a pocket.

16. The apparatus of claim **7**, wherein the holder is sized to fit one of a beverage cup, a liquid container, a fluid bottle, a baby bottle, a baby food container, a Styrofoam cup, a soda can, a soda bottle, an ice cream cone, a pack of cigarettes, a condiment, a magazine, a newspaper, a business card, money, coins, a boarding pass, a passport, a driver's license, a cell phone, a smart phone, a mobile computing device, an IPOD, an IPAD, a tool, a portable drill, a screwdriver, a pair of pliers, a hammer, a brush, a toothbrush, a contact lens case, eye-glasses, a comb, a hat, gloves, earplugs, nose plugs, a wallet, a camera, binoculars, a sports drink, an energy bar, a swim

cap, a towel, body tape, an air pump, sandals, a heart rate monitor, a timing chip, or a tire patch kit.

**17.** The apparatus of claim 7, wherein the flexible band attaches to an article via a non-slip surface of the flexible band.

**18.** The apparatus of claim 7, wherein the apparatus reduces when removed from the handle into a compact configuration for storage in a clothing pocket.

\* \* \* \* \*