



(43) International Publication Date
24 December 2014 (24.12.2014)

- (51) International Patent Classification:
C11C 5/00 (2006.01)
- (21) International Application Number:
PCT/US2014/041924
- (22) International Filing Date:
11 June 2014 (11.06.2014)
- (25) Filing Language: English
- (26) Publication Language: English
- (30) Priority Data:
13/920,123 18 June 2013 (18.06.2013) US
- (71) Applicant: S.C. JONSON & SON, INC. [US/US]; 1525
Howe Street, Racine, WI 53403 (US).
- (72) Inventors: SHARMA, Nitin; 6138 - 114th Avnue, Ken-
osha, WI 53142 (US). GILLIGAN, Allyce, M.; 626 E.
Kilbourne Ave., Apt. 308, Milwaukee, WI 53202 (US).
- (74) Agent: MEIER, Linda, Blair; S.c. Johnson & Son, Inc.,
1525 Howe Street, Racine, WI 53403 (US).
- (81) Designated States (unless otherwise indicated, for every
kind of national protection available): AE, AG, AL, AM,

AO, AT, AU, AZ, BA, BB, BG, BH, BN, BR, BW, BY, BZ, CA, CH, CL, CN, CO, CR, CU, CZ, DE, DK, DM, DO, DZ, EC, EE, EG, ES, FI, GB, GD, GE, GH, GM, GT, HN, HR, HU, ID, IL, IN, IR, IS, JP, KE, KG, KN, KP, KR, KZ, LA, LC, LK, LR, LS, LT, LU, LY, MA, MD, ME, MG, MK, MN, MW, MX, MY, MZ, NA, NG, NI, NO, NZ, OM, PA, PE, PG, PH, PL, PT, QA, RO, RS, RU, RW, SA, SC, SD, SE, SG, SK, SL, SM, ST, SV, SY, TH, TJ, TM, TN, TR, TT, TZ, UA, UG, US, UZ, VC, VN, ZA, ZM, ZW.

(84) Designated States (unless otherwise indicated, for every kind of regional protection available): ARIPO (BW, GH, GM, KE, LR, LS, MW, MZ, NA, RW, SD, SL, SZ, TZ, UG, ZM, ZW), Eurasian (AM, AZ, BY, KG, KZ, RU, TJ, TM), European (AL, AT, BE, BG, CH, CY, CZ, DE, DK, EE, ES, FI, FR, GB, GR, HR, HU, IE, IS, IT, LT, LU, LV, MC, MK, MT, NL, NO, PL, PT, RO, RS, SE, SI, SK, SM, TR), OAPI (BF, BJ, CF, CG, CL, CM, GA, GN, GQ, GW, KM, ML, MR, NE, SN, TD, TG).

Published:

— without international search report and to be republished upon receipt of that report (Rule 48.2(g))

(54) Title: CANDLE DISPENSER

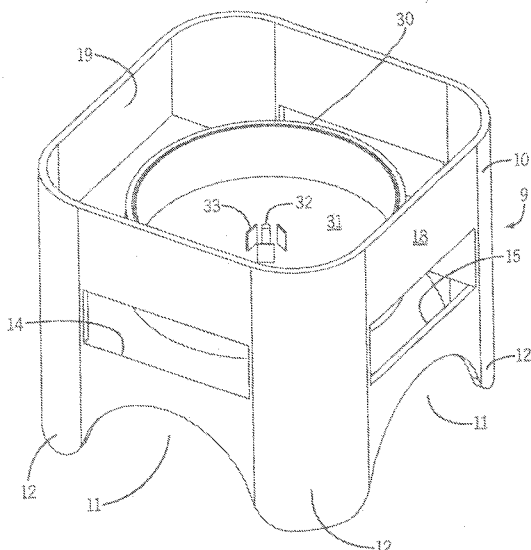

FIG. 1

(57) Abstract: Devices dispense air treatment chemicals in response to heat generated by a candle. Heat transfer elements carry flame heat to an impregnated substrate that is positioned mostly or entirely below the candle. The air treatment chemical vapors are kept away from prolonged direct exposure to flame heat, thereby reducing heat degradation of the active. The candle automatically adjusts heat transfer rates to correct for decreasing amounts of active on the substrate as the substrate nears being used up.



CANDLE DISPENSER

CROSS-REFERENCE TO RELATED APPLICATIONS

[0001] Not applicable

STATEMENT REGARDING FEDERALLY SPONSORED
RESEARCH/DEVELOPMENT

[0002] Not applicable

BACKGROUND OF THE INVENTION

[0003] The present invention relates to devices that dispense air treatment chemicals from a substrate using the heat of a candle to drive the dispensing. More particularly, the invention relates to such devices that have been configured to protect the air treatment chemical from heat degradation (a/k/a "pyrolysis") during such dispensing.

[0004] A variety of devices are known for dispensing volatilizable air treatment chemicals such as pest control materials (e.g., insecticides, insect repellants, or insect growth control regulators), air scents or deodorizers (e.g. masks), allergen control ingredients, disinfectants, sanitizers or other materials. In some of these devices the air treatment chemical is mixed with candle wax and is dispensed during a candle burning process (where the chemical is released primarily from the heated wax surrounding the wick). While this is a common technique for dispensing a variety of fragrances, typically it has been less successful when dispensing certain particularly desirable pest control materials.

[0005] Attempts have been made to use the heat from a candle (or other similar heat source) to distribute air treatment chemicals from an adjacent impregnated pad surface or the like. See e.g. U.S. Pat. Nos. 2,742,342, 4,781,895, 6,482,365, 6,503,459, and 7,138,130. However, these devices typically placed the pad directly over the candle flame, leading to heat spikes directly over the flame, as well as sometimes too little heat adjacent the periphery of the pad.

[0006] Another approach was to position a chimney directly over the candle flame, with the impregnated substrate positioned around the chimney. See e.g. U.S. patent 8,047,837. While this made the pad able to more efficiently dispense some additional types of air treatment chemicals, it did not completely address pyrolysis and/or uneven heating problems.

[0007] Still another approach was disclosed in U.S. patent application publication 2009/0004067. There, an air treatment chemical was coated on a radially outer

periphery of a candle cup. The heat of the candle heated the walls of the candle cup, and that heat was used to drive the air treatment chemical off. However, this type of heat transfer was relatively inefficient, and (in any event) placing the active at a typical gripping position for the candle could cause some consumers to have concerns about the possibility of touching and/or interfering with the active.

5 [0008] Thus, a need continues to exist for improved candle dispensers where the heat of a candle drives an air treatment chemical off of a carrier substrate, albeit with reduced pyrolysis concerns.

BRIEF SUMMARY OF THE INVENTION

10 [0009] In one aspect the invention provides a device for dispensing an air treatment chemical. The device has a housing for supporting a candle and a candle supported on that housing. The candle has a wick that can be lit to create a flame fueled by the candle. There is also a substrate bearing an air treatment chemical positioned at least in part under the candle.

15 [0010] In preferred forms a heat transfer fin is positioned adjacent the candle wick, the heat transfer fin comprises a metal such as aluminum, and the heat transfer fin widens in a downward direction such that as more of the candle is used up more of the fin can be directly exposed to heat generated from a flame of the candle. The heat transfer fin transfers heat from the candle flame to a heat transfer radial extension that extends under the candle.

20 [0011] The substrate is preferably positioned under the heat transfer radial extension such that heat from a candle flame can be used to drive air treatment chemical off of the substrate. In one form the substrate comprises sand coated with a binder, and the housing has a support ledge for supporting the candle and has an inlet for providing air to the candle.

25 [0012] In another aspect the invention provides a device for dispensing an air treatment chemical. It has a housing for supporting a candle, a candle supported on the housing, the candle having a wick that can be lit to create a flame, and a substrate bearing an air treatment chemical that is mounted at least in part under the candle.

30 The substrate is positioned such that heat from the candle flame, if the wick is lit, can drive air treatment chemical out of the housing (e.g. out of a radial outlet, or past the flame area out of the housing via an axial side channel).

[0013] In still other forms of the invention there is provided a refill for a device of the above kind. The refill has a container, candle wax in the container, a wick

extending in the candle wax, and a heat transfer structure mounted below and also axially along the candle wax. The heat transfer structure comprises an axially extending fin structure and a lower radial extension, the fin structure being positioned at least in part adjacent an upper portion of the wick. There is also a porous substrate positioned adjacent the radial extension, the porous substrate bearing the air treatment chemical. If the wick is lit, heat from a flame created thereby can heat the fin structure, which can transfer heat to the lower radial extension, which can transfer heat to the porous substrate, which can then dispense air treatment chemical.

[0014] It is particularly preferred that the fin structure widen in a downward direction, and there can be a peel off cover positioned under a lower side of the substrate until just before use. The heat transfer structure can be made of aluminum, and the refill can, for example have at least 10gm of wax and at least 10 mg of air treatment chemical.

[0015] Some embodiments of the invention provide lower radial outlet(s) below the candle that direct air treatment chemical away from flame vapors. Other embodiments cause air treatment chemical to pass up an axial side channel past the flame area and then out of the housing. Regardless, the invention helps avoid exposing most of the active to prolonged periods of direct flame heat.

[0016] Heat from burning of the candle passes to the substrate to drive air treatment chemical off the substrate (and ultimately out of the housing). Placing the substrate below the candle allows candle wax to insulate heat spikes adjacent the substrate. Because less direct heat is reaching the substrate than if the substrate were directly over the flame, the substrate is preferably altered to more easily release active upon heating. This can be achieved in a number of ways, most preferably by forming the substrate of a sand core mixed with a binder resin, and/or by using a very volatile active.

[0017] In a preferred form only a single refill unit is required to use the assembly (as distinguished from requiring a separate wax refill and a separate substrate refill). This makes the device more intuitive for consumers to use (e.g. detailed use instructions are not required). The consumer merely places a refill on a platform, and lights the candle as they would for a standard candle.

[0018] In the most preferred embodiments the system self-adjusts as the substrate gets closer and closer to being "used up". As that is about to happen (as the amount of

candle wax decreases), the heat reaching the substrate will increase, thereby insuring that the rate of dispensing does not drop off sharply too quickly.

[0019] Certain embodiments of the invention also help prevent unintended human contact with the substrate since the substrate is neither directly above the candle flame, nor accessible on a radial periphery of the housing. Moreover, the components of the assembly are relatively inexpensive to produce.

[0020] The foregoing and other advantages of the present invention will be apparent from the following description of the preferred embodiments. As these embodiments are merely illustrative, they are not intended to represent the full scope of the invention. Thus, reference should therefore be made to the claims herein for interpreting the scope of the invention.

BRIEF DESCRIPTION OF THE DRAWINGS

[0021] FIG. 1 is an upper perspective view of a first candle dispenser embodiment of the present invention;

[0022] FIG. 2 is a rotated upper perspective view of an outer housing portion thereof;

[0023] FIG. 3 is lower perspective view of the FIG. 1 assembly;

[0024] FIG. 4 is a perspective view of a candle refill structure of FIG. 1, albeit shown separated from the outer housing of FIG. 2;

[0025] FIG. 5 is an exploded perspective view of the candle refill structure of FIG. 4;

[0026] FIG. 6 is a perspective view of an alternative embodiment of a candle dispenser;

[0027] FIG. 7 is another perspective view, but of a third embodiment of a candle dispenser;

[0028] FIG. 8 is a perspective view of a fourth, most preferred, embodiment;

[0029] FIG. 9 is another perspective view of the fourth embodiment, but with the candle refill removed;

[0030] FIG. 10 is an exploded perspective view of the FIG. 9 assembly;

[0031] FIG. 11 is a perspective view of a candle refill of the FIG. 8 embodiment;

[0032] FIG. 12 is an exploded perspective view of the FIG. 11 assembly; and

[0033] FIG. 13 is a schematic sectional view of the FIG. 8 embodiment, showing the air flow paths.

DETAILED DESCRIPTION OF THE PREFERRED EMBODIMENTS

[0034] A first assembly 9 for dispensing an air treatment chemical is shown in FIGS. 1-5. Its major subcomponents are an outer housing 10 (FIG. 2) and a candle/substrate refill 30 (FIG. 4).

[0035] The outer housing 10 is in the form of a four-legged lower table that has 5 arched apertures 11 between corner legs 12. A support/platform 13 extends horizontally adjacent a first set of opposed slit openings 14, and a second set of opposed slit openings 15. The support/platform 13 has a central, circular opening 16. Upper walls 18 define an internal cavity 19 for holding the refill 30.

[0036] Refill 30 is sized so as to fit within the internal cavity 19, with a bottom 10 portion of the refill open to the area defined by the legs 12 under opening 16. Enough space is left in the internal cavity 19 around the refill 30 so that air may easily pass into opposed slit openings 15, up outside the refill 30, and to the area of the candle wick. This helps feed fresh air to the candle, and ultimately helps carry flame vapors out of the outer housing 10.

[0037] The refill 30 has a sleeve-like container 36 in which is positioned a wax 15 disk 31 through which extends a wick 32. Adjacent the wick in the wax are positioned multiple axially extending heat transfer fins 33 that may be made of a metal such as aluminum or steel, and which are preferably integrated into a lower metal "spider" having radial extensions 34. Heat from a candle flame can be carried 20 by a heat transfer structure down to and then along these extensions, and then passed to disk form substrate 37. Optionally, an insulating sleeve 39 may be positioned in the container 36.

[0038] While the substrate may be made of various porous materials, in one 25 preferred form it is made of silica sand coated with a binder such as novolac resin. See generally U.S. patent 7,629,001. This is then impregnated with an air treatment chemical such as a repellent that has been dissolved in a hydrocarbon solvent. When a peel-off seal (compare peel-off seal 40C in FIG. 12) has been removed from the refill 30 (immediately prior to the refill being placed in the outer housing 10), heating of the substrate permits active to be driven downward through aperture 38, opening 16 30 and then slit openings 14. This pathway directs the dispensed air treatment chemical away from the candle flame vapors. Surprisingly, enough heat still reaches the substrate for effective insect (e.g. mosquito) control.

[0039] As the wax is being used up the amount of remaining active on the substrate will decrease. Absent other structures of the present invention this could have reduced

the rate of active being dispensed to unacceptably low levels too early in the product life. Thus, it is proposed to widen the fins in the downward direction. As the wax level drops due to the burning of the candle, this increases the amount of fin area exposed to air and then more heat is able to reach the fin area. This increases the amount of heat reaching the substrate, and thereby helps keep the dispensing rate more constant, for longer.

[0040] Light projected by the candle provides an additional light source, as well as desired aesthetics (e.g. when ornamental apertures like radial holes 51 are used, or upper walls 18 are transparent). This is notwithstanding the desirability of minimizing accidental snuffing of the candle.

[0041] The wax disk 31 can be made of a conventional candle wax (e.g. paraffin). Optionally, another secondary air treatment chemical (e.g. a fragrance, citronella) may be mixed in with the wax. The outer housing 10 may alternatively be made of any desired heat resistant material (e.g. a tin plated steel).

[0042] Air treatment chemicals may be presented in a wide variety of formulations. See U.S. Pat. Nos. 6,309,986 and 6,337,080 for disclosure of a variety of insect control materials, deodorizers, fragrances, sanitizers, and disinfectants known to be suitable for use with heating dispensers. For example, suitable active materials may include (when the volatile material is an insecticide and/or insect repellent), organic phosphorous insecticides, lipidamide insecticides, natural repellents as citronella oil, natural pyrethrins and pyrethrum extract, and synthetic pyrethroids. Suitable alternative synthetic pyrethroids are acrinathrin, allethrin as D-allethrin, Pynamin, benfluthrin, bifenthrin, bioallethrin as Pynamin Forte, S-bioallethrin, esbiothrin, esbiol, bisoresmethrin, cycloprothrin, cyhalothrin, lambda-cyhalothrin, cyphenothrin, empenthrin, esfenvalerate, fenpropathrin, fenvalerate, flucythrinate, tauflualinate, kadethrin, metofluthrin, phenothrin, prallethrin as Etoc, resmethrin, tefluthrin, tetramethrin, or transfluthrin. It is preferred to use a more volatile active when seeking insect control in a large space or outdoors on a patio. For example, one can use metofluthrin or transfluthrin where mosquito control is of primary interest.

[0043] When the active is applied to the substrate it may be coated on or impregnated in various ways. For example, the active can be mixed into a hydrocarbon or other solvent, and drops of the mix can be released above the substrate.

[0044] The amount of candle wax can be coordinated with the characteristics of the substrate and air treatment chemical such that just as the candle wax is being used up the air treatment chemical is being used up as well. Alternatively, there can be a color change cue or other timing feature associated with the wax which advises the public as to an optimal time to replace the refill.

[0045] The refill 30 is intended to be sold in packaging designed to inhibit release of active before use (beyond what the peel off seal achieves). For example, there can be a tear open pouch (not shown) in which the refill is positioned prior to use.

[0046] While the above describes a first embodiment of the present invention, it should be appreciated that other embodiments are also within the intended scope of the invention. For example, the support need not have exactly the same number of openings as shown, and the top of the refill need not be completely within an upper cavity of the outer housing 10.

[0047] As shown in FIG. 6, the concept can be implemented with a generally cylindrical structure 50 (see openings 14A and inlet 15A). Note that in this embodiment the air inlets below the substrate of that embodiment do not extend through "legs". Rather, they are radial holes 51 in a skirt 52.

[0048] A third embodiment (FIG. 7) shows an even more cylindrical structure 60 (having openings 14B and 15B) with a lower skirt 62 having inlets 61.

[0049] In a fourth embodiment (FIGS. 8-13) the parts are mostly analogous except that structures are provided to insure that air into which active has been dispensed passes upward, rather than radially outward. Hence, similar or analogous parts have been provided a similar number designation, albeit with a "C" thereafter.

[0050] The FIG. 8 assembly 9C has an outer housing 10C in the form of an apertured platform. There is also a refill 30C.

[0051] The lower portion of the outer housing 10C has apertures 11C which allow air to pass in and up through an aperture 16C. Supports/platforms 13C hold the refill 30C away from blocking aperture 16C and the refill has a small enough diameter to permit air to pass up by it inside upper walls 18C (thereby forming an axial side air pathway that is largely distinct from the area of the candle flame) when the refill 30C is placed inside internal cavity 19C.

[0052] As best understood from FIG. 12, the refill 30C comprises a wax disk 31C having a wick 32C and a heat transfer member 33C/34C. The heat transfer member has fins 33C that extend through the wax disk 31C to carry heat from the flame area

down to a radially extending portion 34C. These parts are inserted into container 36C above an impregnated substrate 37C. A peel-off seal 40C removably covers the bottom of container 36C until use.

5 [0053] As will be appreciated from FIG. 13, when using this embodiment air enters through apertures 11C and passes up to the bottom of the refill 30C. Active driven off the substrate 37C mixes into that air and the mix then passes outward and then up between the refill 30C and the wall 18C.

10 [0054] Most of the active laden air is quickly moved past the area of the wick 32C. Thus, even though in this embodiment the active does not radially exit the container below the candle, there is still a substantial reduction in pyrolysis as compared to having the substrate positioned over the candle flame.

[0055] As is evident from radially extending portion 34C in FIG. 12, the radial heat transfer extensions can be in other forms than as shown in FIG. 5 at 34. They could also be a simple aluminum disk, or have other radially extending constructions.

15 [0056] Thus, the invention is not to be limited to just the specific embodiments shown or described, and the following claims should be looked to in order to judge the full scope of the invention.

[0057] Industrial Applicability

20 [0058] Disclosed herein are improved candle dispenser devices, and refills for use therewith, particularly those designed to reduce unwanted pyrolysis of air treatment chemicals that are dispensed by devices of this general type.

[0059] All documents cited in this patent are, in relevant part, incorporated herein by reference. The citation of any document is not to be construed as an admission that it is prior art with respect to the present invention.

CLAIMS

1. In a device 9 for dispensing an air treatment chemical, the device being of the type comprising a housing 10 for supporting a candle 31; a candle 31 supported on the housing 10, the candle having a wick 32 that can be lit to create a flame; and a substrate 37 bearing an air treatment chemical that is mounted adjacent the candle;

the improvement comprising:

the substrate is mounted at least in part under the candle.

2. The device of claim 1, wherein a heat transfer structure 33/34 is positioned adjacent the candle wick.

3. The device of claim 2, wherein the heat transfer structure comprises aluminum.

4. The device of claim 2, wherein the heat transfer structure comprises a fin 33C that widens in a downward direction such that as more of the candle is used up more of the fin can be directly exposed to heat generated from a flame of the candle.

5. The device of claim 4, wherein the heat transfer fin can transfer heat from the candle flame to a heat transfer radial extension 34 that extends under the candle.

6. The device of claim 5, wherein the substrate is positioned under the heat transfer radial extension such that heat from a candle flame can drive air treatment chemical out of the housing.

7. The device of claim 1, wherein the substrate comprises sand coated with a binder.

8. The device of claim 1, wherein the housing has a support ledge 13 for supporting the candle, and an inlet 15 for providing air to a flame of the candle.

9. In a device 9 for dispensing an air treatment chemical, the device being of the type comprising:

a housing 10 for supporting a candle 31;

a candle supported on the housing, the candle having a wick 32 that can be lit to create a flame; and

a substrate 37 bearing an air treatment chemical that is mounted adjacent the candle;

the improvement comprising:

the substrate is mounted at least in part under the candle and positioned such that heat from the candle flame, if the wick is lit, can drive air treatment chemical out of the housing.

10. In a refill 30 for a device 9 for dispensing an air treatment chemical, the refill being of the type comprising:

a container 36; and

candle wax 31 in the container with a wick 32 extending in the candle wax;

the improvement comprising:

a heat transfer structure 33/34 mounted below and also axially along the candle wax, the heat transfer structure having an axially extending fin structure 33 and a lower radial extension 34, the fin structure being positioned at least in part adjacent an upper portion of the wick; and

a porous substrate 37 positioned adjacent the radial extension, the porous substrate bearing the air treatment chemical;

wherein, if the wick is lit, heat from a flame created thereby can heat the fin structure, which can heat the lower radial extension, which can heat the porous substrate, which can then dispense air treatment chemical.

11. The refill of claim 10, wherein the fin structure widens in a downward direction.

12. The refill of claim 10, further comprising a peel off cover 40C positioned under a lower side of the substrate.

13. The refill of claim 10, wherein, the heat transfer structure comprises aluminum.

14. The refill of claim 10, wherein the refill comprises at least 10gm of wax and at least 10 mg of an air treatment chemical selected from the group consisting of insect repellents and insecticides.

15. In a refill 30 for a device 9 for dispensing an air treatment chemical, the refill being of the type comprising:

a container 36; and

candle wax 31 in the container with a wick extending in the candle wax;

the improvement comprising:

a heat transfer structure 33/34 mounted to the candle wax; and

a porous substrate 37 bearing the air treatment chemical positioned at least in part below the candle wax;

wherein, if the wick is lit, heat from a flame created thereby can heat the heat transfer structure, which can heat the porous substrate below the candle wax, which can then dispense air treatment chemical.

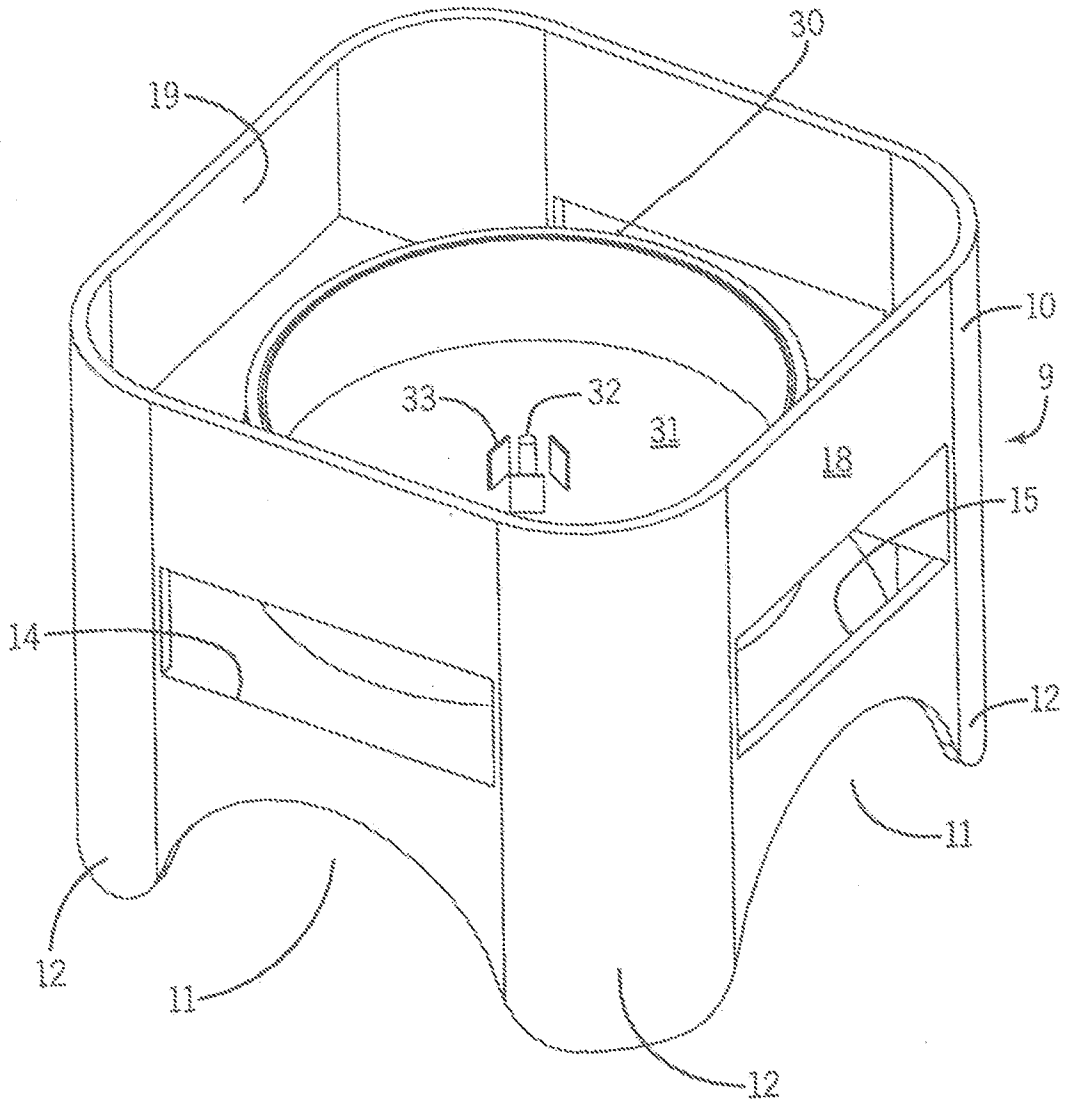

FIG. 1

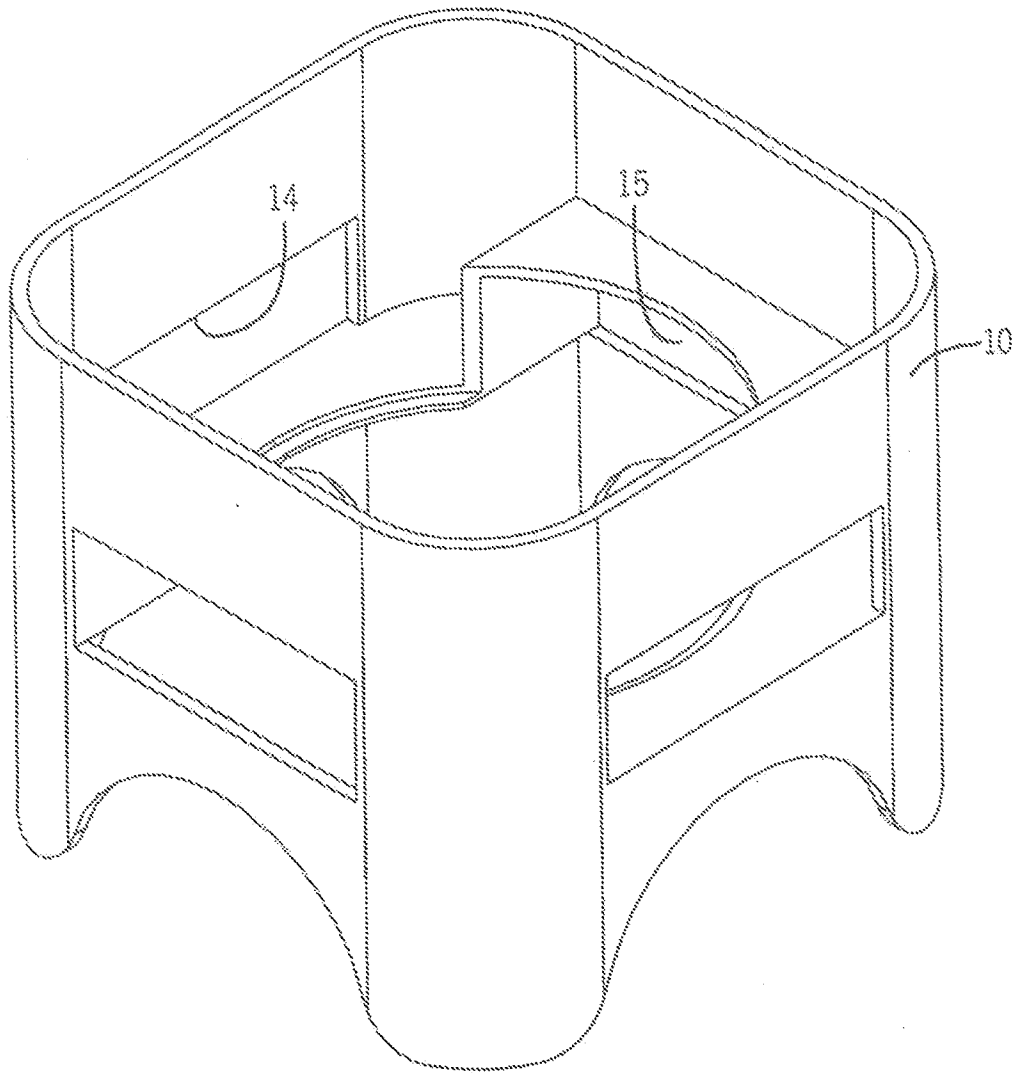

FIG. 2

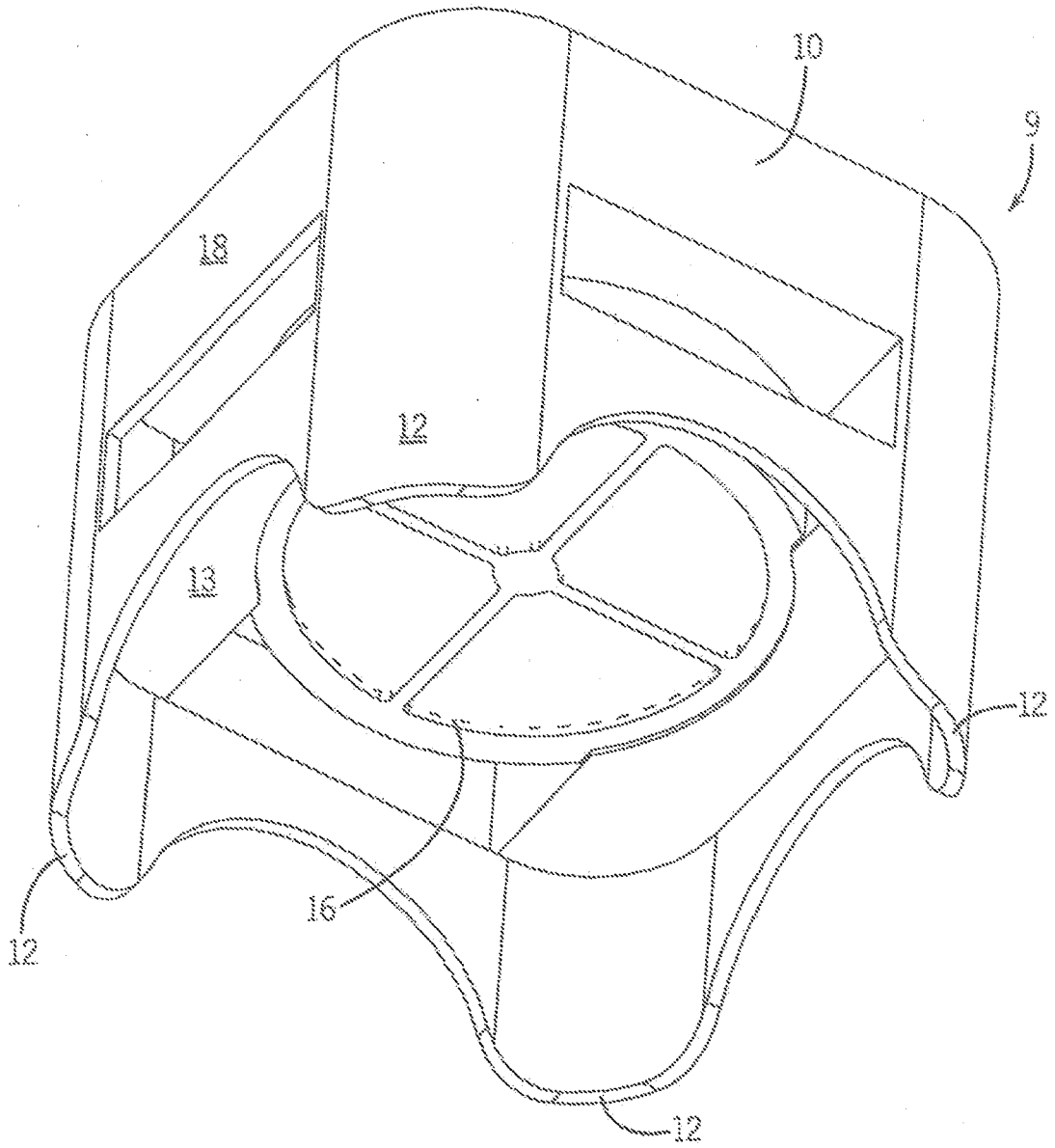

FIG. 3

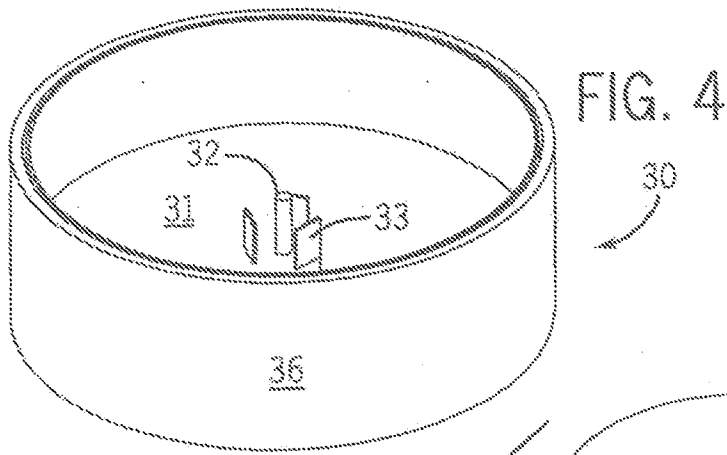
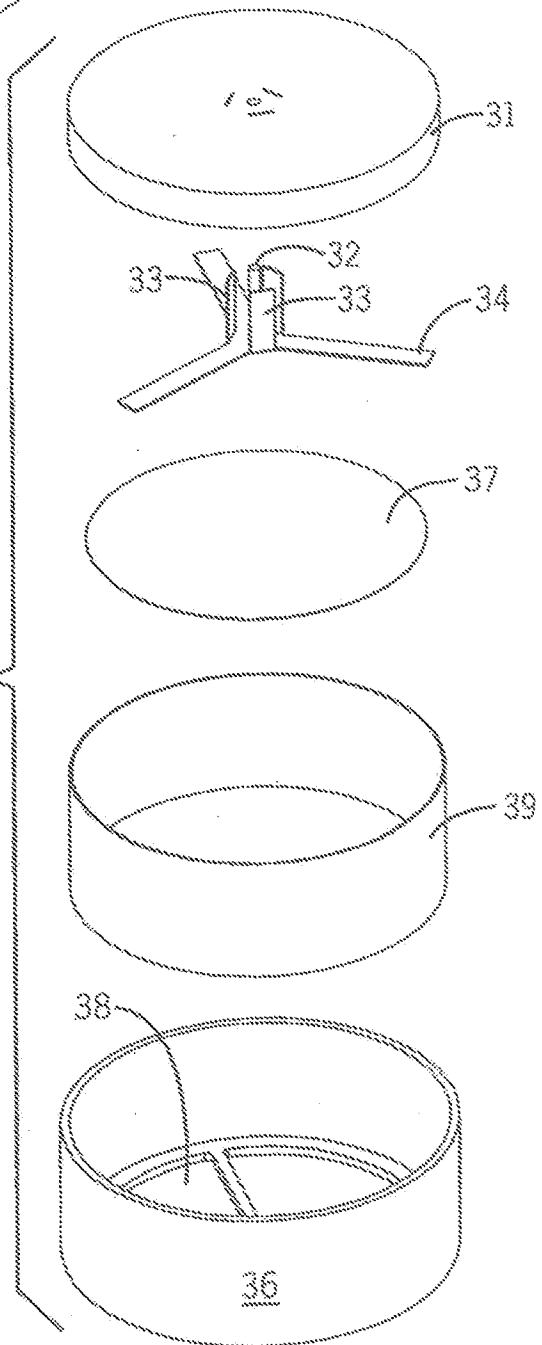

FIG. 5



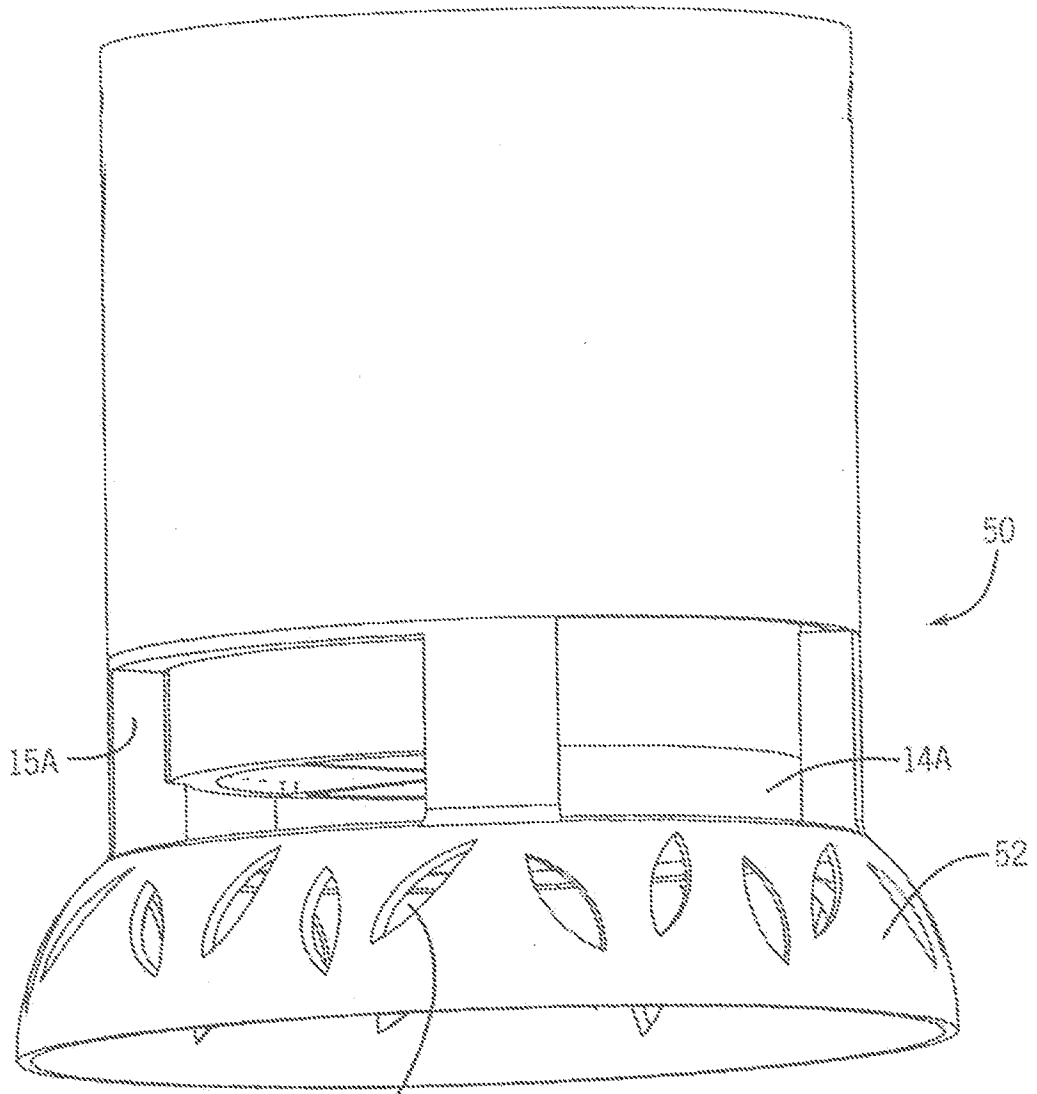

FIG. 6

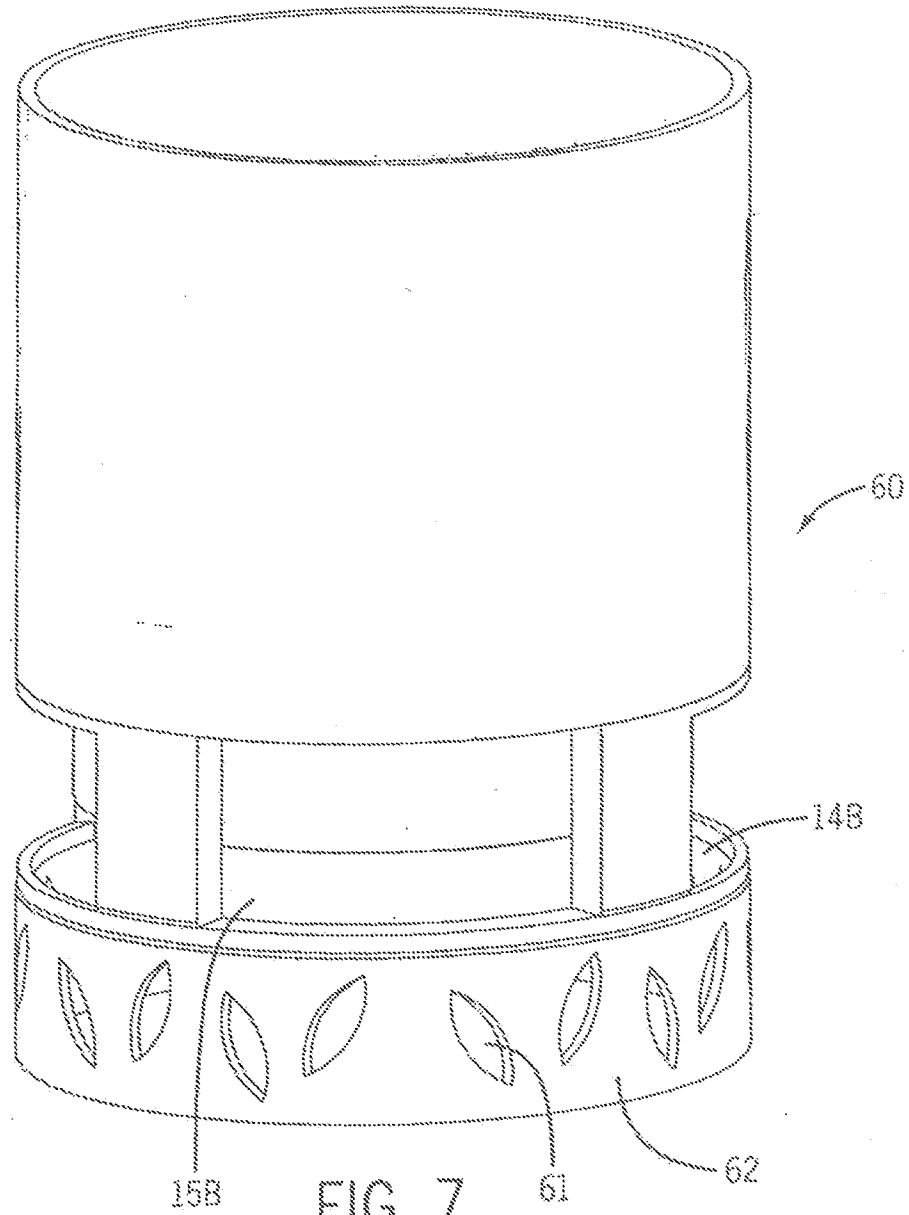

FIG. 7

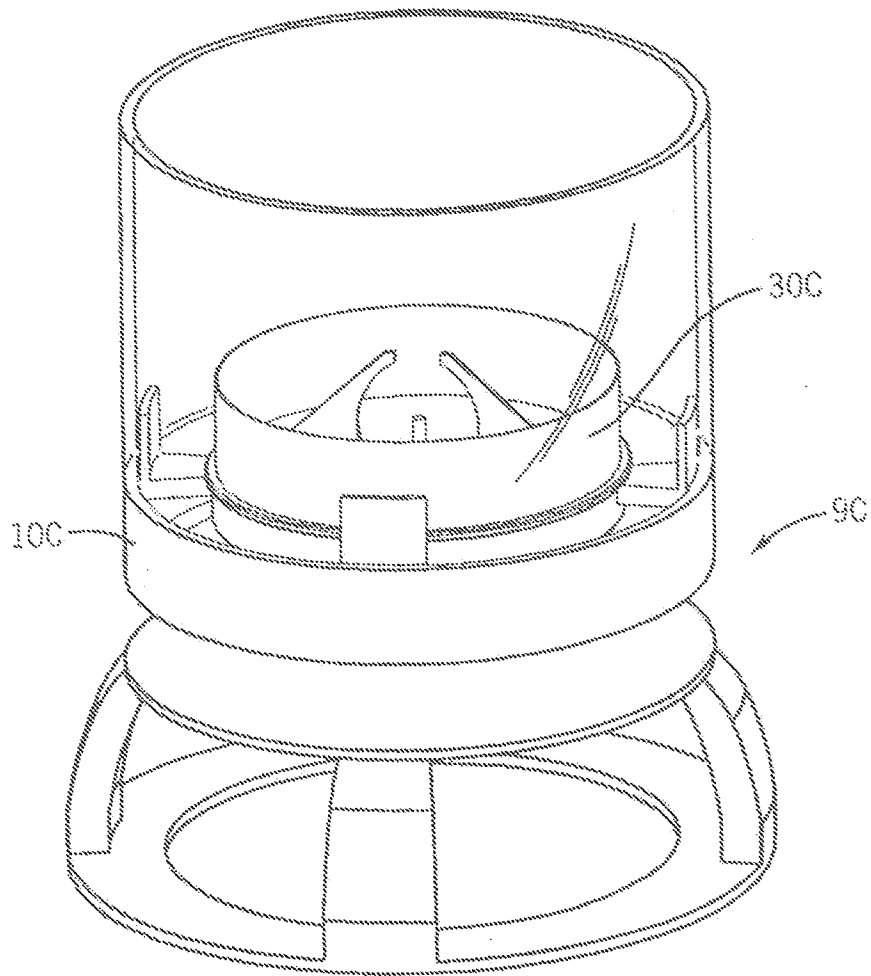

FIG. 8

8 / 10

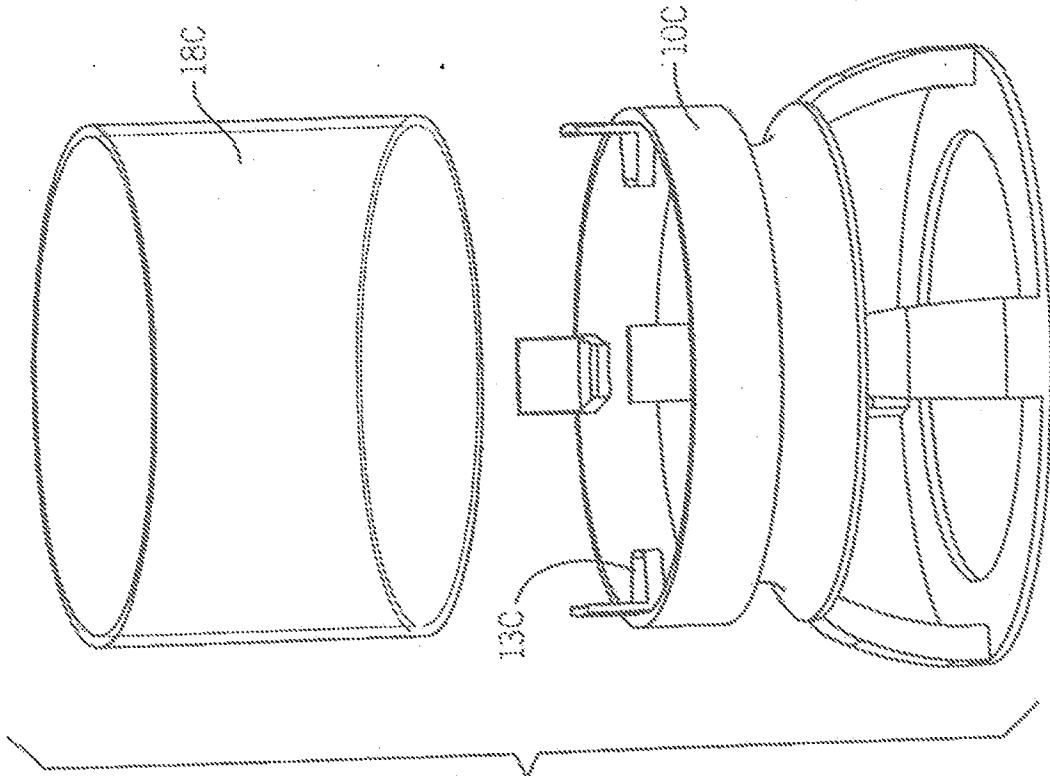

FIG. 10

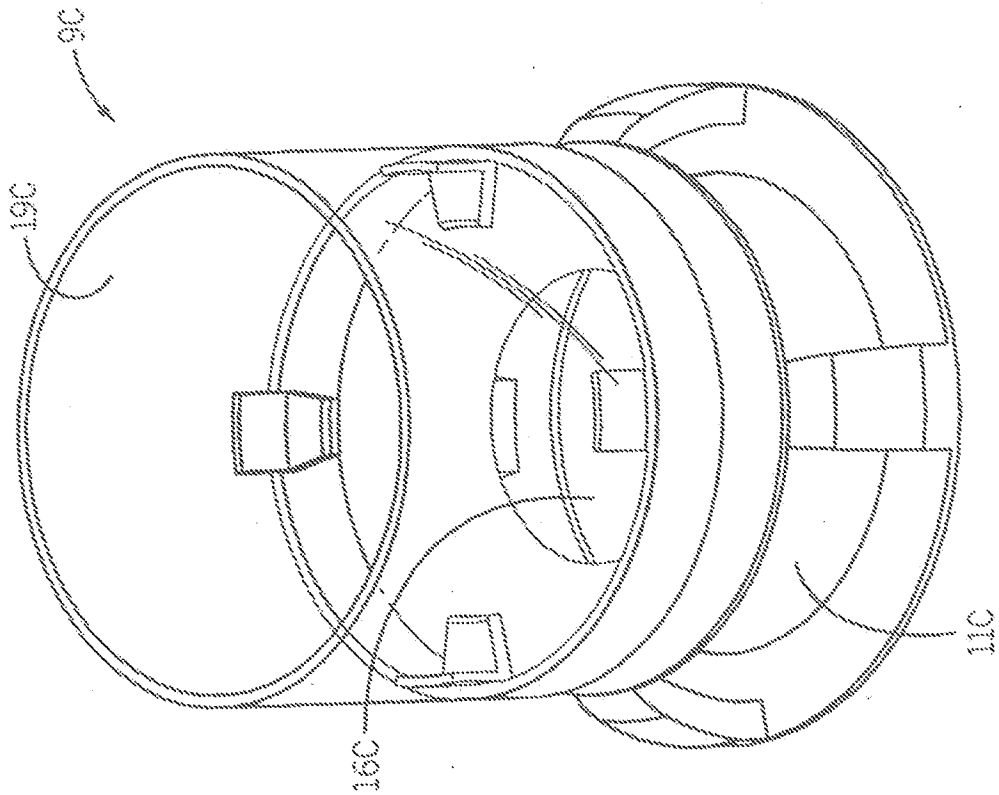

FIG. 9

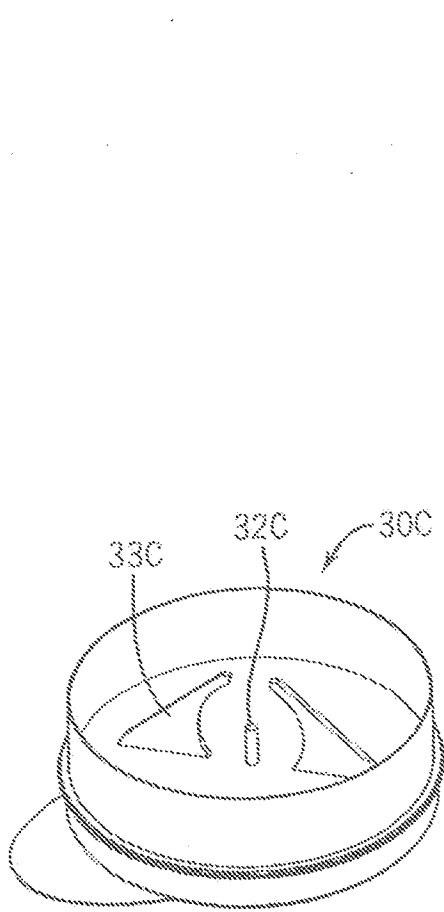

FIG. 11

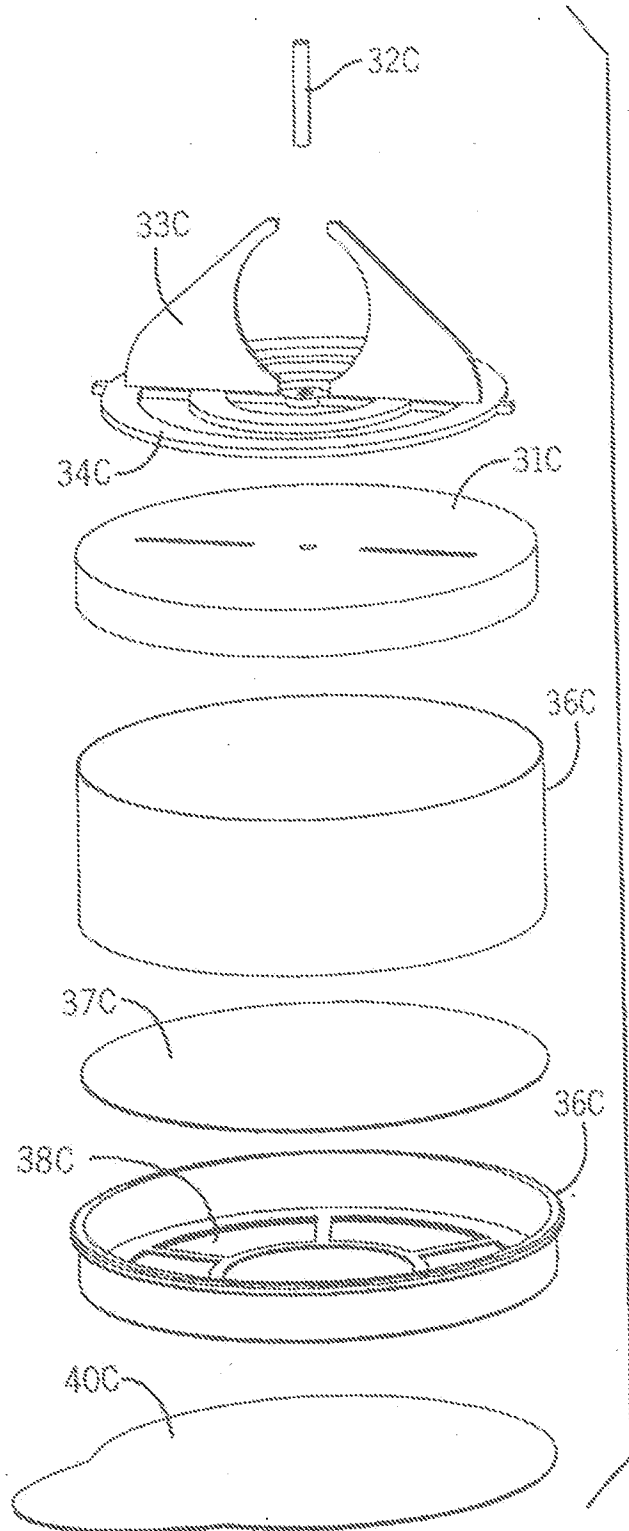

FIG. 12

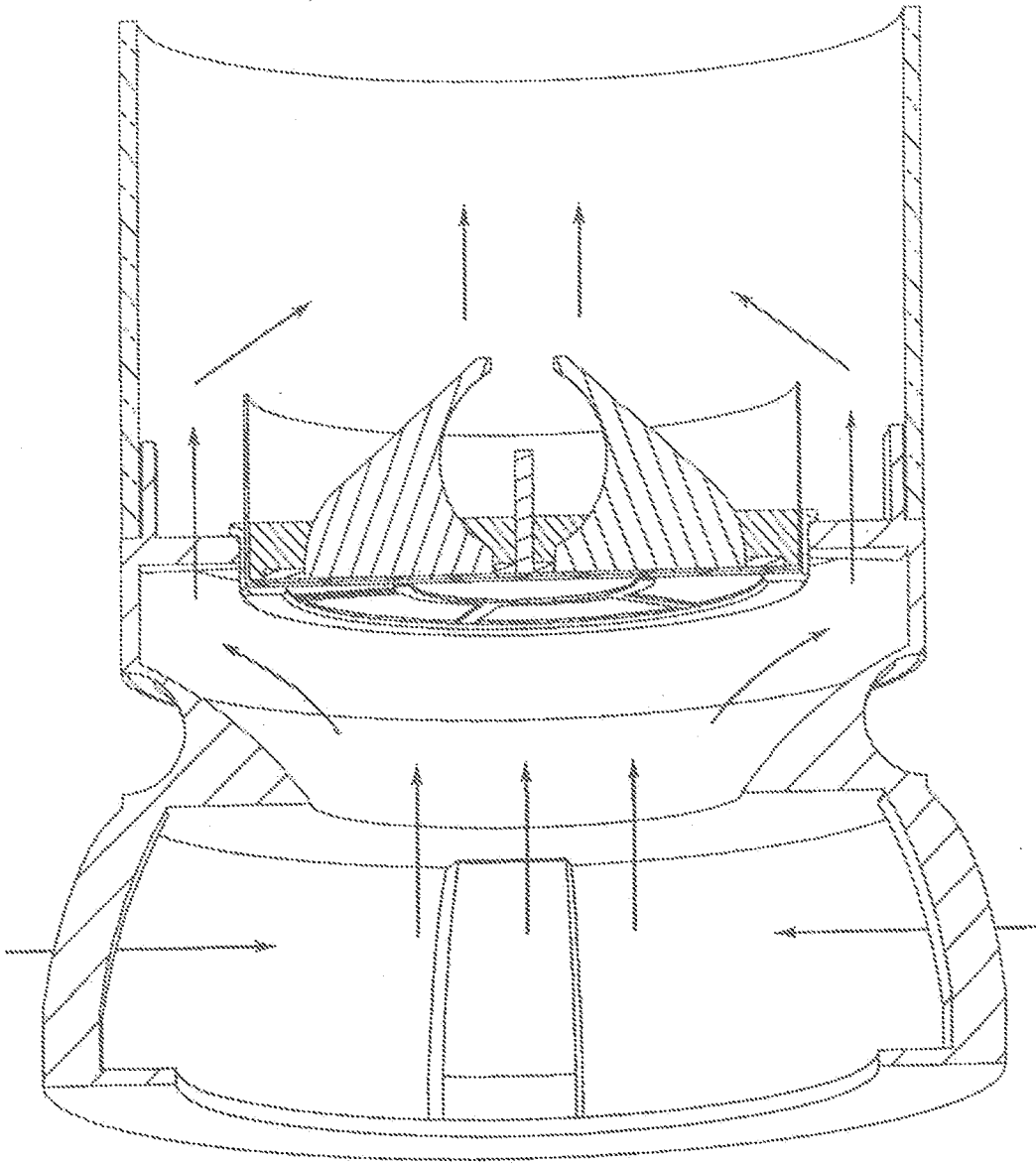

FIG. 13