

Dec. 7, 1965

A. A. VENGHIATTIS

3,221,655

SELECTIVE SHAPED CHARGE GUN

Filed June 26, 1963

2 Sheets-Sheet 1

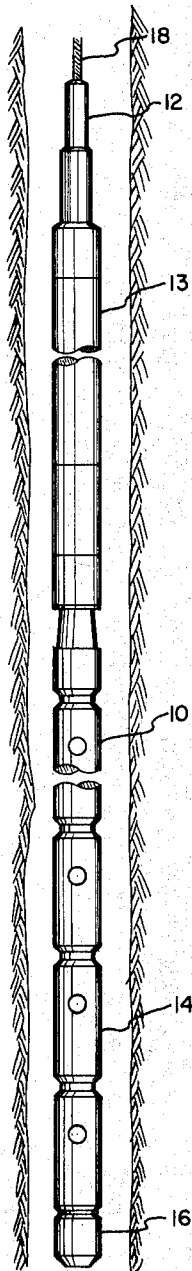

FIG. 1

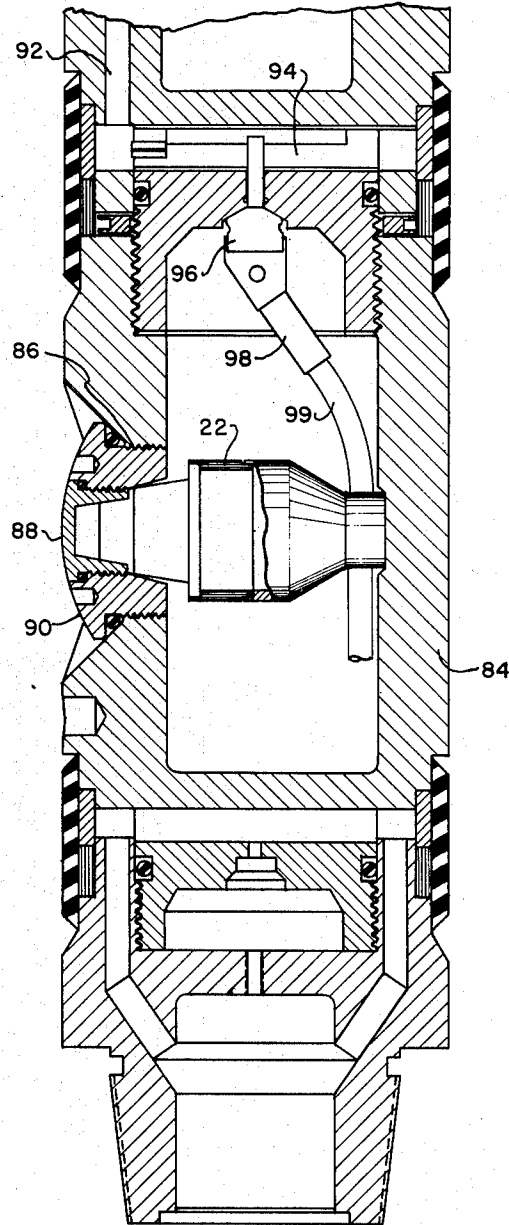

FIG. 3

INVENTOR

ALEXIS A. VENGHIATTIS

BY

Russell E. Schlorff

ATTORNEY

Dec. 7, 1965

A. A. VENGHIATTIS

3,221,655

SELECTIVE SHAPED CHARGE GUN

Filed June 26, 1963

2 Sheets-Sheet 2

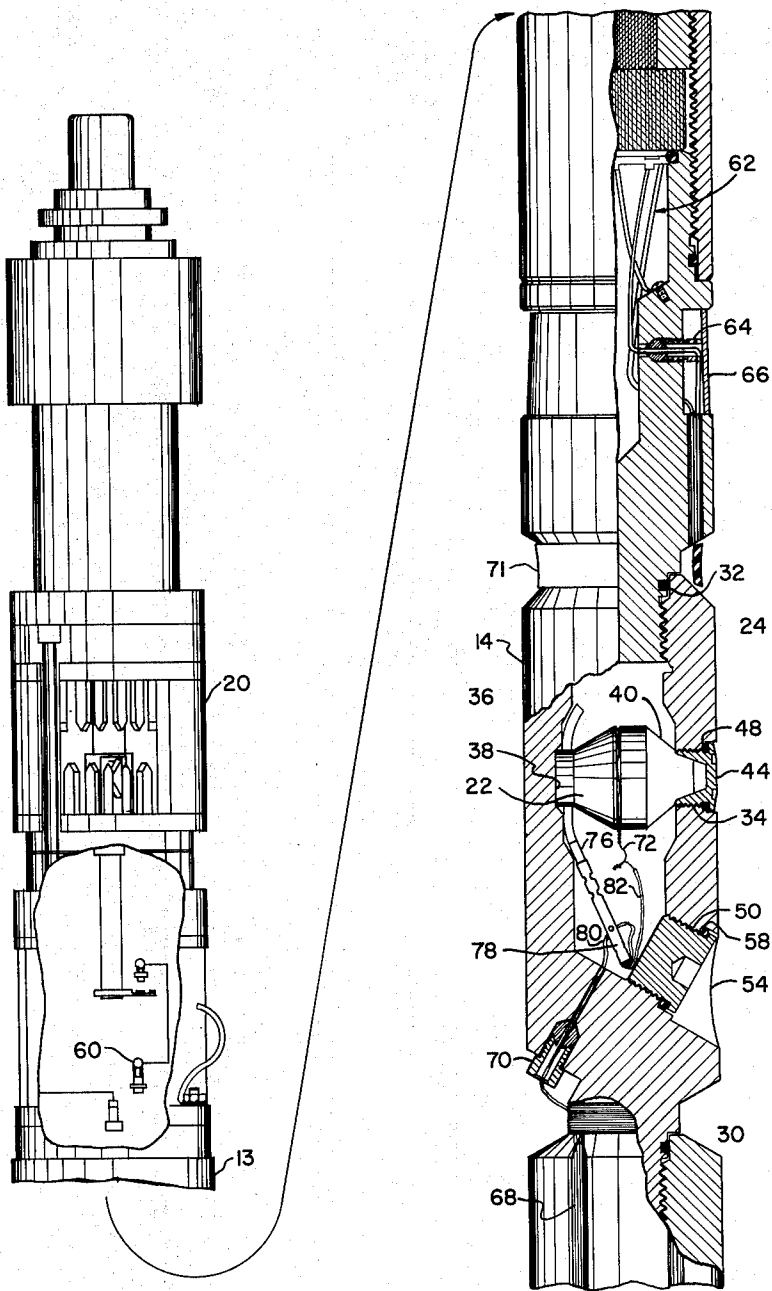

FIG. 2

INVENTOR.

ALEXIS A. VENGHIATTIS

BY

Russell E. Schlorff

ATTORNEY

1

3,221,655

SELECTIVE SHAPED CHARGE GUN

Alexis A. Venghiattis, Houston, Tex., assignor to Dresser Industries, Inc., Dallas, Tex., a corporation of Delaware

Filed June 26, 1963, Ser. No. 290,685

1 Claim. (Cl. 102-20)

The present invention relates to shaped charge well casing perforation apparatus and more particularly to a new and improved hollow carrier gun, which will individually and selectively fire shaped charges which are contained in the gun.

It has become common practice in the completion of oil and gas wells to perforate the well casing to bring the well into production by the utilization of detonating explosives of high velocity and of the general character and form known as "shaped charges" as, for example, the type disclosed by U.S. Patent No. 2,399,211 to C. O. Davis et al., issued April 30, 1946.

In order to position the shaped charges opposite the proper strata in the well bore, the shaped charges are mounted in a carrier which is lowered to the proper location. One common form of carrier is that disclosed in U.S. Patent 2,494,256 to M. Muskat et al. issued January 10, 1950, which discloses a plurality of shaped charges mounted in an elongated, tubular, enclosed, pressure resistant housing commonly referred to in the industry as a hollow carrier gun. Customarily, a hollow carrier gun is made in lengths of 6' and 10', carrying four charges per foot. Generally, a common fuse cord or primacord connects the various shaped charges and they are fired in rapid succession resulting in a multitude of penetrations in the well casing they are opposing.

While in the past it has been the practice of the petroleum industry to complete an oil producing strata by firing a saturation of charges into the strata, the practice has changed whereby it is now the practice of the industry to make only a selective number of penetrations in an oil bearing strata. In some instances, the charges are fired at widely spaced depth intervals as required by the industry's "Limited Entry" technique. On the other hand, the industry's "Single Point Entry" technique, used in high capacity hydraulic well fracturing, requires a number of charges to be selectively fired at one predetermined plane to form a notch. It is necessary, in order to meet such requirements with present equipment, to make a number of runs into the well with the hollow carrier gun being loaded with one or two shaped charges for each run. The numerous runs into the well necessitate the service company to be in attendance at the well site a long time, as well as requiring considerable downtime for the rig, which is a loss to the well operator.

While controllers for sequentially firing bullet guns have been known in the art, they have not heretofore been used for the selective firing of individual shaped charges in a hollow carrier type gun, since the hollow carrier type gun does not contain any barriers between the individual shaped charges; and the shrapnel resulting from the detonation of the charge would cause spontaneous detonation of all the charges contained in the gun.

In order to overcome the aforementioned disadvantages of the prior art, it is the object of the present invention to provide a hollow carrier gun for shaped charges which will permit the selective firing of individual shaped charges whereby the required number of charges may be fired in one trip into the well, even though the spacing for the charges is at a distance greater than the length of the hollow carrier gun employed, or are all on one plane.

It is another object of the present invention to provide an improved hollow carrier gun for shaped charges which

2

permits the selective firing of individual shaped charges contained in the gun.

These and other advantages of the invention, which will more clearly appear from a detailed description which is about to follow, are achieved in an improved hollow type carrier perforating gun which is adapted to be inserted into a well bore. The hollow type carrier gun includes a controller section which is provided with firing means having a plurality of firing positions and with means to sequentially advance one position upon each subsequent energization of the firing means. In order to lower the hollow type carrier gun into the well and properly position it, a cable is attached to the controller section. The cable is provided with one or more conductors to permit energization of the controller device. Serially attached to the lower end of the controller section is a plurality of individual, generally tubular, pressure resistant housings. The gun sections are so constructed that when they are serially attached each section is isolated from its adjacent section. In each of the gun sections is positioned an individual shaped charge. Each gun section is of sufficient strength to act as a barrier and prevent shrapnel from the detonated charge in said section from contacting the shaped charges in other sections. An individual detonator device is attached to each shaped charge and a lead extends from each of the firing positions on the firing means to each of the individual detonators whereby upon energization of the firing means one of the shaped charges will be detonated and upon subsequent energization of the firing means the other shaped charges will be sequentially detonated.

The invention will be described with greater particularity with reference to the drawings in which:

FIG. 1 is a vertical section of a portion of an oil well showing an exemplary embodiment of the hollow carrier gun of the invention suspended in a well;

FIG. 2 is an enlarged, fragmentary, partially sectional view of the hollow carrier well perforating gun shown in FIG. 1;

FIG. 3 is a sectional view of an alternate type of individual gun section.

Referring now to the drawings, the gun assembly 10 is comprised of a cable head adapter 12, a controller section 13, a plurality of individual gun sections 14 and a bull plug 16. In order to lower the gun assembly 10 into a well bore, a conductive cable 18, which contains an insulated conductor or conductors through which the firing may be controlled, is attached to the cable head adapter 12. As indicated in FIG. 1, the controller section 13 contains a fire control means 20. While the present invention is not specifically concerned with such fire control means 20, this control means will be referred to in more detail hereinafter.

The gun assembly 10 is provided with a multiplicity of sub-assemblies, each of which forms an individual gun section 14 in which is located an individual shaped charge 22. Each gun section 14 is formed of a generally elongated, steel cylinder of sufficient strength to contain the explosive force of the firing of the shaped charge 22. One end of each gun section 14 is provided with female threads 24 which, in the uppermost gun section 14, mate with the male threads on the lower end of the sub attached to the lower end of the controller section 13. The lower end of each gun section 14 is provided with male threads 30. Accordingly, the various gun sections 14 are serially connected together to form the overall gun body. The end portions of the gun sections act to form a barrier between adjacent gun sections, isolating each gun section. Attached to the lowermost assembly is the bull plug 16 which forms the lower end of the gun assembly 10. An O-ring seal 32 is pro-

vided in each threaded connection to make the inner connected gun sections fluid-tight, inasmuch as the explosive force of the shaped charge 22 could cause the gun section 14 to burst if extraneous fluid has seeped into and partially filled the gun section.

Each gun section 14 is provided with a gun port 34, which extends into a central bore or chamber 36 of the gun section 14. The shaped charge unit 22 is mounted in the chamber 36 in such a manner that the jet shaped blast projecting from the forward end thereof will issue through the center of the port 34. To assist in positioning and accurately maintaining each charge 22 in centered relation with its respective port 34, the inner wall of the chamber 36 diametrically opposite each port 34 is provided with suitable means to engage the rear end of the charge unit 22. Preferably such means may take the form of a radially-directed cylindrical recess 38, and the adjacent rear end of the shaped charge 22 is cooperatively shaped to fit within the recess 38. To support the forward end of the shaped charge unit 22 and to maintain the rear end securely seated in the recess, a retainer means is employed, as shown at 40. Such retainer means also serves to center the adjacent forward end of the charge in accurate axial alignment relative to the center of its port 34. The retainer means 40, shown in FIG. 2, is in the general form of a hollow, truncated cone, with thick end portions for telescoping engagement with the forward end of the shaped charge 22 and gun port 34 respectively. The port 34 is provided with female threads, and a removable closure member 44, provided with male threads, is threadedly engaged with the female threads of the port to close the gun port 34. An O-ring seal ring is positioned in the closure member 44 to prevent entrance of well fluid. As previously mentioned, the jet from the shaped charge 22 issues through the port 34 and closure member 44 and this member is replaceable after each firing.

Each assembly may be provided with an additional port 50 which provides entrance to the chamber 36. This port 50 is of sufficient size to permit the introduction of the shaped charge 22 into the chamber 36 and also permits the arming of the shaped charge 22 in the field as will be explained subsequently. The second port 50 is provided with female threads, and a closure member 54, having male threads, is threadedly engaged with the female threads of the port 50. The closure member 54 is provided with an O-ring seal 58 to prohibit the entrance of well fluid into the chamber 36.

The fire control means 20 is provided with a multiplicity of terminals 60. To each of these terminals 60 is connected an arming wire 62. The fire control means 20 is so constructed that it will sequentially energize a succeeding terminal 60 in response to a signal from the surface. Each individual arming wire 62 extends through a pressure fitting 64 in the controller section 13. An annular seal member 66 may be placed around the assembly where the arming wires 62 extend from the controller section 13. The arming wires 62 then extend along the length of the gun assembly until each individual wire 62 reaches the proper gun section 14 which it is to service. The periphery of the gun sections may be provided with grooves 68 in which the wires 62 are positioned. To prevent excessive splicing of the arming wires, each wire may be wrapped several times around the gun section it is to service. The individual arming wire 62 is inserted into a pressure fitting 70 and extended into the chamber 36. An annular seal member 71 may be placed around the juncture of two gun sections 14 to additionally protect the entry of the arming wire into the gun section. The gun assembly may be fully wired in the shop; and, to further cut down on loading time at the site, the individual shaped charges 22 may also be installed, including a ground wire 72 which is attached to each shaped charge. The base of each shaped charge is provided with a trans-

verse operation which should be aligned with the port 50 to facilitate field arming.

On arrival at the site, the closure member 54 is removed and a relatively safe and shock-sensitive, detonatable fuse 76 (such as, for example, primacord) is attached to the base of shaped charge 22. To attach the fuse 76 to the base of the shaped charge 22 the fuse 76 is passed through an aperture 74 as indicated in FIG. 2. One end of the primacord 76 is attached to a blasting cap 78 which is provided with two leads 80 and 82. The lead 80 is attached to the arming wire 62 and the other lead 82 is attached to the ground wire 72. The closure member 54 is then replaced and when all sections are so prepared the gun is ready for selective firing of the individual charges 22.

FIG. 3 illustrates an alternate gun section 84 which is generally similar to gun section 14 but has only a single port 86 leading into the chamber. The port 86 is large enough to permit arming and insertion of the shaped charge 22. The closure member for the port 86 is made in two sections 88 and 90 with the section 88 receiving the jet from the charge and replaceable each time. The gun section 84 also permits all of the arming wires to be enclosed by inserting the arming wires through longitudinal passages 92 in the gun section 84. The arming wire is attached to a contact stud 94 to which is connected an ignition device 96. A booster 98 connects the ignition device 96 to the primacord 99, which is inserted into the base of the shaped charge in a manner similar to that shown in FIG. 2. The gun section 84 may be serially attached in a manner similar to gun section 14. Also the charges contained therein may be selectively fired as previously described in connection with FIG. 2.

As can be seen from the foregoing, there is provided an improved, hollow carrier type perforating gun in which each individual shaped charge 22 is completely contained in its own gun section 14 ready to be individually fired. Each gun section 14 is a complete pressure resistant unit, itself. Also, the various gun sections, in assembly, form a pressure resistant assembly, whereby entrance of well fluid into the assembly or any individual gun section is prohibited. Moreover, each gun section 14 is so designed that it will resist the explosive forces resulting from the ignition of the shaped charge. Moreover, each shaped charge is protected from shrapnel from an adjacent charge so that the detonation of one charge will not cause the spontaneous detonation of an adjacent charge. Further, the gun is so designed that the gun may be fully wired and charges installed at the shop, the gun then safely transported to the well site and the completion of the arming expeditiously accomplished at the site. Furthermore, the gun is so designed that each individual charge may be selectively detonated either at spaced intervals or at the same level all in one trip into the well, resulting in a minimum of rig downtime.

What is claimed is:

An improved hollow carrier gun for shaped charges comprising:

a controller section provided with firing means having a plurality of firing positions and means to sequentially advance one position upon each subsequent energization;

a plurality of individual, generally tubular, gun sections, one end of said gun sections formed into a male connecting end portion and the other end formed into a female connecting end portion, one end of the first of said gun sections detachably secured to the controller section, another of said gun sections detachably secured to the other end of said first gun section, the remainder of said gun section detachably secured together serially;

a shaped charge chamber in each gun section, a shaped charge in said chamber, an individual denotator attached to said shaped charge, a port in each gun section communicating with the

5

chamber, the port being of sufficient size to accommodate the entry of the shaped charge,
 a replaceable sealed closure member for said port,
 a second port spaced from the first port in each gun section communicating with the chamber, said second port being coaxial with the axis of the shaped charge in said chamber,
 a replaceable sealed closure member for said second port, said replaceable closure member presenting an area of lesser strength for the jet of the shaped charge,
 each gun section being an independent hollow carrier gun having sufficient strength to isolate the shaped charge from external borehole pressure and contain the fragmentation resulting from denotation of its shaped charge;
 an insulated lead for each gun section, each lead attached to one of the firing positions of the firing means,
 a pressure type fitting in the controller section through which the insulated leads extend,

5
10
15
20

6

each lead extending along the periphery of the gun sections until it reaches the gun section it services, a pressure fitting in each gun section through which the lead servicing such gun sections enters the chamber and is attached to the denotator.

References Cited by the Examiner

UNITED STATES PATENTS

2,655,619	10/1953	Neal	166—55.5
2,667,836	2/1954	Church et al.	102—20
2,703,053	3/1955	Castel	102—20
2,742,857	4/1956	Turechek	102—20
2,792,783	5/1957	Delacour	102—20
2,946,283	7/1960	Udry	102—20
3,010,396	11/1961	Coleman	102—21.6

BENJAMIN A. BORCHELT, *Primary Examiner.*

SAMUEL FEINBERG, *Examiner.*

V. R. PENDEGRASS, *Assistant Examiner.*