

H. SCHREINER.

Car Starter.

No. 112,640.

Patented March 14, 1871.

FIG. 1

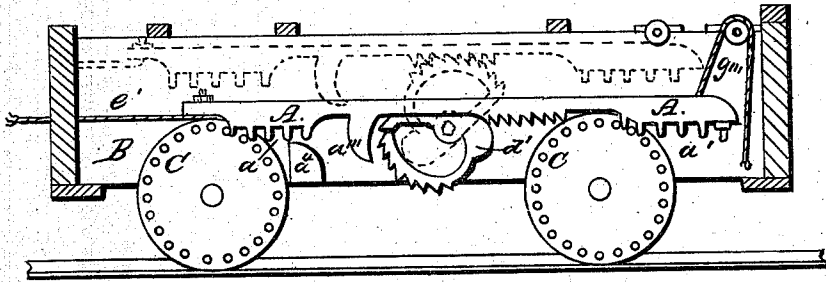

FIG. 2.

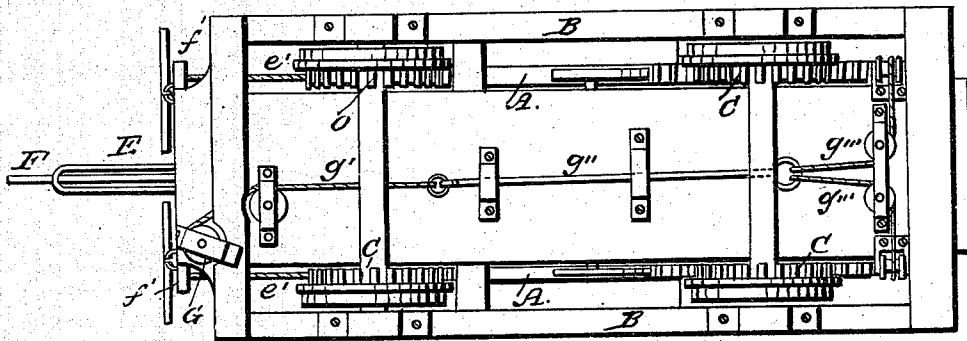
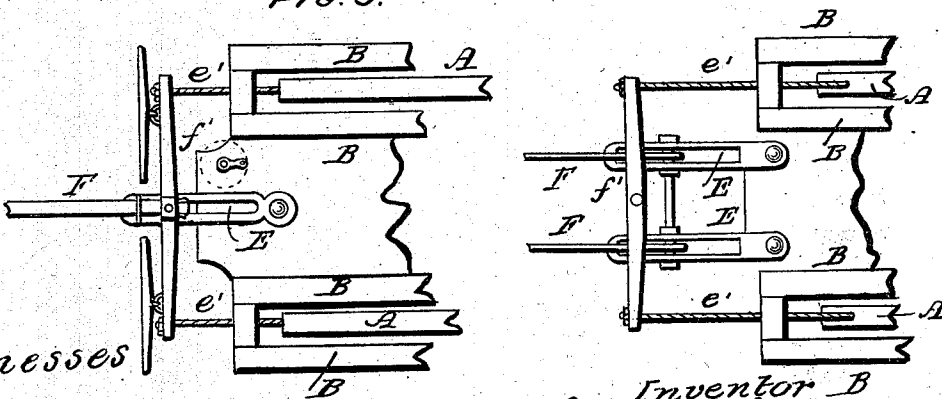

FIG. 3.



Witnesses
E. Morrison
C. H. Morrison

Inventor B
Henry Schreiner.

United States Patent Office.

HENRY SCHREINER, OF PHILADELPHIA, PENNSYLVANIA.

Letters Patent No. 112,640, dated March 14, 1871.

IMPROVEMENT IN HORSE-CAR STARTERS.

The Schedule referred to in these Letters Patent and making part of the same.

I, HENRY SCHREINER, of the city of Philadelphia, in the State of Pennsylvania, have invented certain Improvements in the Apparatus for Facilitating the Starting of Horse-Cars on Railways, of which the following is a specification.

Nature and Objects of the Invention.

My invention relates to the construction and arrangement of certain rack-bars, eccentric swinging bars, slotted guides, and retracting cords or chains, to operate, in combination with the bottom frame, shafts, or pole, wheels, and braking-lever of a car, substantially as hereinafter described and set forth; the object of my invention being to enable the driver to readily apply the tractile power of the horses near to the upper parts of the rims of all the wheels at once in starting the car forward, and also to enable him to retract the said rack-bars with facility in the operation of braking the wheels to arrest the forward motion of the car.

Description of the Accompanying Drawing.

Figure 1 is a vertical longitudinal section of the bottom frame and the wheels of a car embodying my invention.

Figure 2 is a plan view of the under side or bottom of the car, with my invention applied.

Figure 3 is a sectional plan view of the upper side of the driver's platform, showing the manner of attaching the draft-pole and its double-tree to the slotted guide and rack-bars.

Figure 4 is a like section of the driver's platform, showing the manner of attaching the draft-shafts and their single-tree to the slotted guide and rack-bars.

General Description.

The rack-bars A A are arranged parallel to each other and to the side sills B B of the car, so as to be directly above the teeth or cogs C C, on the inner sides of the wheels of the car.

On the under side of each end of the bars A A are downward projecting teeth *a' a'*, which will gear into easy connection with the cogs C C and pull the wheels around when the said bars A A are drawn forward.

Between the two series of teeth *a' a'* of each rack-bar there is a series of notches or serrated teeth, *a''*, and below each series the ratchet-toothed or notched eccentric lever D swings freely in such a manner that its teeth or notches are borne upward by its weighted end *d*.

Between the teeth *a'*, at the forward end of each of the rack-bars, and the serrated teeth *a''*, there is a projection, *a'''*, which comes in contact with and slips up

upon a stationary block, *a'*, which is fixed to the frame at a point near the forward wheel, and thus raises up the rack-bar when the said bars are being drawn backward toward their inoperative position.

The ratchet-toothed eccentric levers D D are each constructed and applied so that, as the rack-bars are being drawn backward, the teeth *a' a'* catch first in the highest tooth of the levers D D and then in the succeeding teeth, and in this manner the said rack-bars are raised upward by the said eccentric levers D D far enough to free their teeth, *a' a'*, entirely from the cogs C C of the wheels, (see dotted lines in ng. 1.)

The teeth of the levers D D having passed out of contact with the teeth *a' a'* of the rack-bars A A, the said levers D D fall over rearward, and remain suspended loosely on their fulcrums until the rack-bars A A, on being drawn forward to pull the wheels around, slide over them, as represented by the full lines in fig. 1.

The slotted guide or guides E E are pivoted securely to the front end of the floor-frame of the car, and the pole or shafts F, with their double or single-tree, *f' f'*, attached, slide in the said slotted guide or guides, respectively, the ends of the single or double-tree being respectively connected with the forward ends of the two rack-bars A A by means of suitable chains or ropes *e' e'*, of such lengths that, when the pole or shafts are drawn near to the outer end of the slot or slots in E, the said rack-bars will be in the position represented in fig. 3; and when the said pole or shafts are slipped back to the rear end of said slots, the rack-bars can be drawn back (as will be explained) to the position shown by the full lines in fig. 1.

For the purpose of enabling the driver to retract the rack-bars A A, an additional pulley, G, is fixed on the lower end of the shaft of the usual braking hand-lever, and from this pulley G a chain or rope, *g'*, and sliding bar *g''*, extend back to two chains *g'''*, which, guided by pulleys, connect with the respective rear ends of the said rack-bars A A, as shown in fig. 2, so that the driver, in operating the braking-lever, causes, at the same time, the said rack-bars to be drawn back into their inoperative positions, (see fig. 1.)

It will be understood without further description that, when the horses are started, the rack-bars A A will be drawn forward, causing their teeth *a'* to catch in the cogs C C near the upper part of the rims of all the wheels at once, and thus simultaneously rotate the wheels or start a loaded car forward without straining the horses, as heretofore, or with much less effort than if the draft was made directly from the axles of the wheels; and that an inequality in the burden of the respective ends of the car at any time will not

cause any difference in the amount of power required to start the car, because all the wheels are operated upon at the same time by the rack-bars.

It will also be seen that the rack-bars are retracted by the driver in braking the wheels, and that the said bars are, at the same time, lifted entirely clear of the cogs in the wheels, so as to prevent any rattling, noise, or friction with the said wheels.

Claim.

I claim as my invention—
The sliding rack-bars A A, the toothed eccentric

swinging levers D D, the stationary block *a'*, the slotted guides E E, pole or shafts F, and chains or ropes *e e*, the pulley G on the braking-lever, chain or rope *g*, bar *g'*, and chains or ropes *g''*, the said parts being constructed and arranged to operate in combination with the bottom frame and the four wheels of the car, substantially as and for the purpose hereinbefore set forth and described.

HENRY SCHREINER.

Witnesses:

BENJ. MORISON,
WM. H. MORISON.