



(51) International Patent Classification:
B65H 5/06 (2006.01)

(21) International Application Number:
PCT/US2019/020301

(22) International Filing Date:
01 March 2019 (01.03.2019)

(25) Filing Language: English

(26) Publication Language: English

(30) Priority Data:
62/641,352 11 March 2018 (11.03.2018) US

(72) Inventor; and

(71) Applicant: **GOODRICH, David Paul** [US/US]; 455 El Camino Road, Sedona, AZ 86336 (US).

(74) Agent: **PARKER, Stephen B.**; Westerman, Hattori, Daniels & Adrian, LLP, 8500 Leesburg Pike, Suite 7500, Tysons, Virginia 22182 (US).

AO, AT, AU, AZ, BA, BB, BG, BH, BN, BR, BW, BY, BZ, CA, CH, CL, CN, CO, CR, CU, CZ, DE, DJ, DK, DM, DO, DZ, EC, EE, EG, ES, FI, GB, GD, GE, GH, GM, GT, HN, HR, HU, ID, IL, IN, IR, IS, JO, JP, KE, KG, KH, KN, KP, KR, KW, KZ, LA, LC, LK, LR, LS, LU, LY, MA, MD, ME, MG, MK, MN, MW, MX, MY, MZ, NA, NG, NI, NO, NZ, OM, PA, PE, PG, PH, PL, PT, QA, RO, RS, RU, RW, SA, SC, SD, SE, SG, SK, SL, SM, ST, SV, SY, TH, TJ, TM, TN, TR, TT, TZ, UA, UG, US, UZ, VC, VN, ZA, ZM, ZW.

(84) Designated States (unless otherwise indicated, for every kind of regional protection available): ARIPO (BW, GH, GM, KE, LR, LS, MW, MZ, NA, RW, SD, SL, ST, SZ, TZ, UG, ZM, ZW), Eurasian (AM, AZ, BY, KG, KZ, RU, TJ, TM), European (AL, AT, BE, BG, CH, CY, CZ, DE, DK, EE, ES, FI, FR, GB, GR, HR, HU, IE, IS, IT, LT, LU, LV, MC, MK, MT, NL, NO, PL, PT, RO, RS, SE, SI, SK, SM, TR), OAPI (BF, BJ, CF, CG, CI, CM, GA, GN, GQ, GW, KM, ML, MR, NE, SN, TD, TG).

(81) Designated States (unless otherwise indicated, for every kind of national protection available): AE, AG, AL, AM,

(54) Title: SLIT SHEET TENSIONING DEVICE

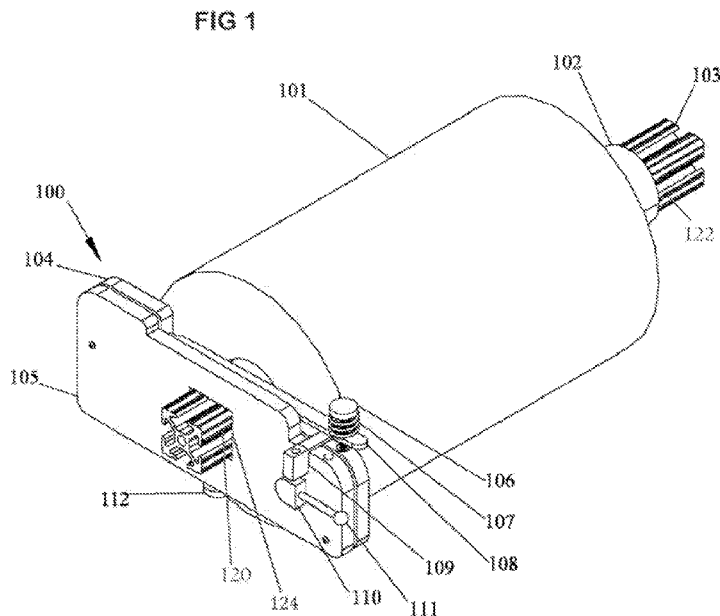

(57) Abstract: An expansion device includes an unexpanded slit sheet roil that is wound on a paper core that is longer than the width of the slit sheet paper roil. The paper core is placed onto a rod member. An adjustable downward pressure is exerted on the paper core and the paper core exerts pressure on the rod member. As the paper is pulled, the downward pressure creates the friction required to enable the unexpanded slit sheet to be unwind and fed while simultaneously expanding.



WO 2020/068153 A2

Published:

- *without international search report and to be republished upon receipt of that report (Rule 48.2(g))*

Title: Slit Sheet Tensioning Device

BACKGROUND OF THE INVENTION

[001] Cross-Reference to related Applications

This application claims the benefit of provisional application 62/641,352, filed 03/11/2018 and is a continuation-in-part of non-provisional patent application 15/428,144 filed 02-08-2017, and is a continuation-in-part of non-provisional patent application 15/820,514, filed, 01-02-2018, the disclosures of which are incorporated by reference in their entirety, referenced and recited herein as if in full as part of the description of the present invention. The disclosures of patent applications 14/480,319 filed 09-08-2014 (US 2016-0067938), and 15/001,168 filed 01-19-2016, (US 2018/0222665) are incorporated herein by reference, as though recited in full.

[002] Field of the Invention

[003] This invention relates to the use of a tensioning device for resisting the unwinding of a roll of slit, expandable paper during the dispensing of expanded slit sheet material.

[004] Description of the Prior Art

[005] The expanded slit paper prior art is disclosed in U.S. Patents No. 5,538,778, 5,667,871, 5,688,578, and 5,782,735, which patents are incorporated by reference in their entirety and recited herein as if in full as part of the description of the present invention. The prior art consists of layering a slit sheet wrapping a combination of a tissue interleave sheet for the purpose of cushioning fragile items for shipment. The prior art also relates to a method of expanding the slit sheet material using an electrically powered apparatus.

SUMMARY OF THE INVENTION

[006] A main object of the present invention is to overcome the shortcomings of the prior art as mentioned in a paragraph above. In accordance with a broad embodiment of the invention, provides a simplified solution to already existing hardware that can support a roll of expanded slit sheet material that only requires the tensioning device.

[007] In accordance with an embodiment of the invention, an expansion device is provided that includes an unexpanded slit sheet roll that is wound on a paper core that is longer than the width of the slit sheet paper roll. The paper core is placed onto a rod member. An adjustable downward pressure is exerted on the paper core and the paper core exerts pressure on the rod member. As the paper is pulled, the downward pressure creates the friction required to enable the unexpanded slit sheet to be unwind and fed while simultaneously expanding.

[008] In accordance with another embodiment of the invention, a device for dispensing expandable slit sheet paper includes a roll of expandable slit sheet paper wound on an interior core member, and mounted on a rod member, said rod member having a rod member end region, a support member, first means for securing the rod member end region to the support member, and means for pressing the core end region against the rod member end region and for variably applying a frictional resistance to the rotation of said core member.

[009] In accordance with a further embodiment of the invention, the interior core member has an axial length that is greater than the width of the slit sheet paper that is wound on said interior core member and has a core member end region that extends beyond the roll of expandable slit sheet paper. The rod member can have four right angle corners.

[0010] In accordance with another further embodiment of the invention, a tensioning means is provided for variably applying a frictional resistance to the rotation of said interior core member. Preferably the tensioning means includes an elongated member hingedly coupled to a support member, a spring, a threaded region in said support member, and a screw member that passes through the spring and is in threaded engagement with the threaded insert. The screw member is rotatable to vary the frictional resistance applied by said elongated member to a core member end region.

[0011] In accordance with still another embodiment of the invention, a means is provided for variably applying a frictional resistance to the rotation of said interior core member and a rod member is provided having four right angle corners and received within an opening in a support member. The opening is rectangular and dimensioned to receive the rod member, and having a threaded member for releasably fastening said rod member to said support member.

[0012] In accordance with an embodiment of the invention, a device for dispensing expandable slit sheet paper includes a roll of expandable slit sheet paper wound on an interior core member and mounted on a rod member. The rod member has a rod member end region. The end region of said interior core member extending beyond the width of said roll of slit sheet paper, advantageously by an amount of at least one inch from said roll of slit sheet paper and preferably at least about one and one half inches from said roll of slit sheet paper. The device further includes a support member and a threaded member for releasably fastening the rod member to the support member.

[0013] In accordance with another embodiment of the invention, a device for dispensing expandable slit sheet paper include a roll of expandable slit sheet paper wound on an interior core member and mounted on a rod member. The interior core member has a pair of end regions extending beyond the width of said roll of slit sheet paper, whereby the roll of expandable slit sheet paper can

be mounted on said rod member for either clockwise or counterclockwise rotation.

[0014] In accordance with still another embodiment of the invention, a method of dispensing and expanding expandable slit sheet paper from a device that comprises a roll of expandable slit sheet paper wound on an interior core member having an axial length that is greater than the width of the slit sheet paper that is wound on said interior core member and has at least one core member end region that extends beyond said roll of expandable slit sheet paper, comprises the steps of positioning said interior core member on a rod member, pressing a core end region against the rod member end region and variably applying a frictional resistance to the rotation of said interior core member. The frictional resistance to the rotation of said interior core member on said rod member is set at a level such that drawing an end of said roll of expandable slit sheet paper against said frictional resistance causes said slit sheet paper to expand. The step of variably setting said frictional resistance to the rotation of said interior core member includes rotating a spring loaded screw member and thereby varying the frictional resistance applied by an elongated member to a core member end region. The spring is positioned between the head of the screw and the elongated member, such that rotation of the screw varies the amount of pressure applied by the spring to the elongated member.

[0015] In accordance with still another embodiment of the invention, a method of dispensing and expanding expandable slit sheet paper from a device that comprises a roll of expandable slit sheet paper wound on an interior core member having an axial length that is greater than the width of the slit sheet paper that is wound on said interior core member and has at least one core member end region that extends beyond said roll of expandable slit sheet paper, and an elongated member which is hingedly coupled to said support member and a spring, said elongated member having a threaded insert and a screw member passing through said spring and into said threaded insert thereby spring

loading said elongated member, wherein the method comprises the steps of positioning said interior core member on a rod member, pressing a core end region against the rod member end region and variably applying a frictional resistance to the rotation of said interior core member. The frictional resistance to the rotation of said interior core member on said rod member is set at a level such that drawing an end of said roll of expandable slit sheet paper against said frictional resistance causes said slit sheet paper to expand. The step of variably setting said frictional resistance to the rotation of said interior core member includes rotating a spring loaded screw member and thereby varying the frictional resistance applied by an elongated member to a core member end region.

[0016] In accordance with still another embodiment of the invention, a method of dispensing and expanding expandable slit sheet paper from a device that comprises a rod member having four right angle corners and received within a correspondingly dimensioned opening in a support member, said first means for securing said rod member end region to said support member is preferably a threaded member releasably fastening the rod member to the support member, comprising the steps of positioning said slit sheet paper wound on an interior core member on said rod member, rotating said threaded member in a first direction to rigidly fix said rod member to said support member, dispensing said slit sheet paper until the roll of expandable slit sheet paper wound on an interior core member is to be replaced, rotating said threaded member in a second direction to release said rod member from said support member, and removing said interior core member from said rod member.

Brief Description of Drawings

[0017] The invention will be described with the accompanying drawings, in which:

[0018] FIG. 1 is a perspective view of the tensioning device.

[0019] FIG. 2 is a side view of the tensioning device's inner tensioning fixture.

[0020] FIG. 3 is a side view of the tensioning device's outer fixture plate with the tensioning device not actuated.

- [0021] FIG. 4 is a side view of the tensioning device's outer fixture plate with de-tensioning device actuated.
- [0022] FIG. 5 is a perspective view of the tensioning as the expanded slit sheet roll is being loaded.
- [0023] FIG. 6 is a perspective view of an alternate de-tensioning device not actuated.
- [0024] FIG. 7 is a perspective view of an alternate de-tensioning device actuated.

Description of the invention

Definitions

- [0025] For the purposes of the present invention the term "cam block" means a lobed device that when rotated provides a pushing action due to its elongated shape.
- [0026] For the purposes of the present invention the term "lobed" means a structure having a rounded or pointed structure that extends from the main structure.
- [0027] For the purposes of the present invention the term "hingedly" means that parts or elements are linked together such that an end of one part or element swings or pivots relative to the part with which it is linked.
- [0028] For the purposes of the present invention the term "connected" means that two parts are releasably or permanently coupled to each other.
- [0029] For the purposes of the present invention the term "releasably" means that a component is capable of being separated from another component with which it is couple.
- [0030] Further information relating to the paper which can be used in the present

invention, slit patterns, and the expansion process is found in U.S. Patents No. 6,712,930, 5,538,778, 5,667,871, 5,688,578, 5,782,735, 3,104,197, 3,220,116, 3,266,972, 3,269,393, 3,908,071, 6,024,832, 6,458,447 and 3,908,071, and applications US14/901,977, WO1984002936A1, US2002/0060034, US 2007/0240841, the disclosures of which are incorporated by reference herein, as though recited in full.

[0031] The tensioning device in its preferred embodiment is to be made from wood and further it is to be made from furniture grade plywood normally found within the art. The tensioning device and specifically the tension rod, spring and thumbscrew are of the same design as found in Non-provisional Patent Application No. 15/428,144. The difference in the present invention is that a single yoke is used and the yoke opening is larger than the paper core and therefore does not contact the paper core. The tension rod presses on the paper core and the paper core rests on a support bar. Thus, there is no need for the yoke to contact the slit sheet roll. In the present invention, the tensioning device has incorporated in it a holding fixture that enables it to be attached to a horizontal support bar. The bar enables the slit sheet roll material to be mounted by means of the support bar passing through the paper core. The edge of the paper core then rests against the holding fixture portion of the tensioning device which, then positions the paper core precisely in place to enable a tension rod to rest in the same fashion as the U.S. Application No. 15/428,144. On the other side of the paper core a removable stop mechanism is preferably provided for preventing the slit sheet roll from moving side to side.

[0032] The horizontal support bar is preferably mounted to the holding fixture by a thumbscrew located underneath the holding fixture. Rotation of the thumbscrew for movement upwards presses the support bar to maintain the tensioning device in a fixed position within the holding fixture. Rotating thumbscrew for movement downwards releases the support bar from its fixed position.

[0033] Once the tensioning device is firmly in position and the paper is mounted it will function in the exact same fashion as in the nonprovisional application 15/428,144. This feature enables the tension bar to be lifted upward and held in position during the time that no tensioning is required to stretch and feed the slit sheet material. In the instance of the present invention, the support bar adds a degree of friction that reduces and or eliminates the requirement for tensioning with the tension rod. When the roll becomes small enough then tension will be required. This device, called the cam block is preferably made of steel or hard plastic and rotated 90 degrees upward lifting a separate lifting block into position that lifts the tension rod upward thus eliminating tension on the paper core. When tension is required the lifting block is lowered by rotating the cam block downward 90 degrees which lowers the lifting block allowing the tension rod to contact the paper core and apply tension. The rod is then released and the preset tension of the tension rod is then applied to the paper core.

[0034] This method of releasing the tension without the requirement of using the thumb screw on the tension bar also allows for easy replacement and removal of the slit sheet roll. Absent this feature the tension rod should be removed to change rolls.

Figures

[0035] Fig 1 is a perspective view of the entire tensioning system 100 with loaded slit sheet roll 101 and paper core 102 loaded onto the horizontally positioned support bar 103. The paper core 102 as seen in Fig 2 is hollow and receives the support bar 103 thus supporting the slit paper roll 101. Tensioning assembly 104 as disclosed in nonprovisional 15/428,144 contains thumbscrew 106 with attached spring 107 pressing on tension rod 108. The tensioning rod 108 is an elongated cantilevered structure carried by the tensioning assembly 104. The tensioning rod is a rigid elongated structural element, such as a beam or a bar, hingedly coupled at one end to a support with which it is coupled. Holding fixture

105 is attached to tensioning assembly 104 and is attached to the support bar 103 with thumbscrew 112. The lifting block 109 is resting on cam block 110 in the downward position by pushing cam block handle 111 downward. An end 120 of the support bar 103 is positioned in a receiving opening 124 in the holding fixture 105. The opposing end 122 of the support bar 103 can be supported by a second holding fixture, not shown, which can correspond to the holding fixture 105 or the tensioning assembly 104.

[0036] FIG 2 is a side view of the tensioning assembly where the paper core 102 does not contact 104 as shown in open area 205. Support bar 103 contacts paper core 102 and thumbscrew 107 applies pressure to both 103 and 102 simultaneously. Contact between the paper core 102, as seen in FIG 2, is at two edges 203 and 204 of the paper core supporting bar 103. While the bar receiving opening and the paper core supporting bar 103 are illustrated as being squares, other shapes can be used such as a rectangle having four straight sides and four right angles, and unequal adjacent sides. Alternatively the shape can be of an irregular hexagon that makes contact with the paper core at two or four points and supports the paper core 102. While the core supporting bar 103 can have a polygonal cross-section, the points of contact between a core supporting bar that the paper core (when viewed in cross-section is advantageously limited to four points, and preferably is two points (as seen in FIG 2, see 203, 204 and 102), for most effective application of pressure to the paper core 102 by the interaction of the tensioning member 108 and the paper a core supporting bar, such as 103 of FIG 2.

[0037] FIG 3 is a side view of the holding fixture 105 that shows the screws 104 that attach it to the tensioning assembly. Thumbscrew 112 is screwed upward and pressed against support bar 103 holding it in position within the opening 303 which is configured to conform to the size and shape of the support bar 103. Horizontally positioned support bar 103 supports the paper core 102 (as seen in Fig 2) and fits into the bar receiving opening 303. The shape of the bar receiving

opening 303 conforms to the peripheral configuration of the horizontal, paper core supporting bar 103. Cam block 110 is in the downward position with lifting block 109 resting on it.

[0038] FIG 4 is a side view showing the cam block 110 rotated upward thus pushing lifting block 109 upward and contacting the tension rod 108 and lifting it beyond the paper core as shown in the open area 400.

[0039] FIG 5 is a perspective view of loading paper roll 101 and paper core 102 onto the support bar 103 with arrow 500 showing the direction of the loading. The edge of the paper core will rest against holding fixture 105 as it passes through the yoke of tensioning assembly 104 while cam block 110 and 109 is in the upward position.

[0040] FIG 6 is a perspective view of the swivel block 600 which, is an alternative lifting mechanism of the tension bar that shows the swivel block 600 in the outward and down position. Tension bar or rod 108 is lifted by hand and the swivel block is rotated in the arrow direction 601 on the axis of the threaded rod 602 to apply the lifting of the tension rod 108.

[0041] FIG 7 is a perspective view of the alternate swivel block 600 in its lifting position.

[0042] The use of individual numerical values is stated as approximations as though the values were preceded by the word "about", "substantially", or "approximately". Similarly, the numerical values in the various ranges specified in this application, unless expressly indicated otherwise, are stated as approximations as though the minimum and maximum values within the stated ranges were both preceded by the word "about", "substantially", or "approximately." In this manner, variations above and below stated ranges can be used to achieve substantially the same results as values within the ranges.

As used herein, the terms "about", "substantially", and "approximately" when referring to a numerical value shall have their plain and ordinary meanings to a person of ordinary skill in the art to which the disclosed subject matter is most closely related or the art relevant to the range or element at issue. The amount of broadening from the strict numerical boundary depends upon many factors. For example, some of the factors which may be considered include the criticality of the element and/or the effect a given amount of variation will have on the performance of the claimed subject matter, as well as other considerations known to those of skill in the art. As used herein, the use of differing amounts of significant digits for different numerical values is not meant to limit how the use of the words "about", "substantially", or "approximately" will serve to broaden a particular numerical value or range. Thus, as a general matter, "about", "substantially", or "approximately" broaden the numerical value. Also, the disclosure of ranges is intended as a continuous range including every value between the minimum and maximum values plus the broadening of the range afforded by the use of the term "about", "substantially", or "approximately". Thus, recitation of ranges of values herein are merely intended to serve as a shorthand method of referring individually to each separate value falling within the range, unless otherwise indicated herein, and each separate value is incorporated into the specification as if it were individually recited herein. To the extent that determining a given amount of variation of some the factors such as the criticality of the slit patterns, paper width differential pre- and post- expansion, paper weights and type, as well as other considerations known to those of skill in the art to which the disclosed subject matter is most closely related or the art relevant to the range or element at issue will have on the performance of the claimed subject matter, is not considered to be within the ability of one of ordinary skill in the art, or is not explicitly stated in the claims, then the terms "about", "substantially", and "approximately" as applied to a numerical value should be understood to mean the numerical value plus or minus 15%.

[0043] It is to be understood that any ranges, ratios and ranges of ratios that can

be formed by, or derived from, any of the data disclosed herein represent further embodiments of the present disclosure and are included as part of the disclosure as though they were explicitly set forth. This includes ranges that can be formed that do or do not include a finite upper and/or lower boundary. Accordingly, a person of ordinary skill in the art most closely related to a particular range, ratio or range of ratios will appreciate that such values are unambiguously derivable from the data presented herein.

What is claimed is:

1- A device for dispensing expandable slit sheet paper, comprising:

a roll of expandable slit sheet paper,
an interior core member,

wherein said roll of expandable slit sheet paper is wound on said interior core member,

said interior core member having an axial length that is greater than the width of the slit sheet paper that is wound on said interior core member and having an interior core member end region that extends beyond said roll of expandable slit sheet paper,

a rod member,

wherein said interior core member is mounted on said rod member,

said rod member having a rod member end region,

a support member,

first means for securing said rod member end region to said support member,

second means for pressing a core end region against said rod member end region and variably applying a frictional resistance to the rotation of said core member.

2- The device of claim 1, further comprising said rod member having four right angle corners.

3- The device of claim 1, wherein said second means for variably applying a frictional resistance to the rotation of said core member comprises:

an elongated member hingedly coupled to said support member,

a spring, said elongated member having a threaded insert, and a screw passing through said spring, and being rotatable to vary the frictional resistance applied by said elongated member to a core member end region.

4- The device of claim 2, wherein said second means for variably applying a frictional resistance to the rotation of said core member comprises:

an elongated member hingedly coupled to said support member,

a spring, said elongated member having a threaded insert, and a screw passing through said spring, and being rotatable to vary the frictional resistance applied by said elongated member to a core member end region.

5- The device of claim 4, wherein said rod member having four right angle corners and received within an opening in said support member, said opening being rectangular and dimensioned to receive said rod member, and having a threaded member for releasably fastening said rod member to said support member.

6- The device of claim 4, further comprising a threaded member for releasably fastening said rod member to said support member.

7- The device of claim 4, further comprising third means fastening said rod member to said support member.

8- The device of claim 1, further comprising each end region of said interior core member extending beyond the width of said roll of slit sheet paper, an amount of at least one inch from said roll of slit sheet paper.

9- The device of claim 2, further comprising each end region of said interior core member extending beyond the width of said roll of slit sheet paper, an amount of at least one inch from said roll of slit sheet paper.

10- The device of claim 3, further comprising each end region of said interior core member extending beyond the width of said roll of slit sheet paper, an amount of at least one inch from said roll of slit sheet paper.

11- The manual expander of claim 10, further comprising each end region of said interior

core member that extends beyond the width of said roll of slit sheet paper, extending at least about one and one half inches from said roll of slit sheet paper.

12- A method of dispensing and expanding expandable slit sheet paper from a device comprising

a roll of expandable slit sheet paper wound on an interior core member, said core member having an axial length that is greater than the width of the slit sheet paper that is wound on said interior core member and having a core member end region that extends beyond said roll of expandable slit sheet paper,

a rod member,

said interior core member being mounted on said rod member,

said rod member having a rod member end region,

a support member,

first means for securing said rod member end region to said support member,

second means for pressing a core end region against said rod member end region and variably applying a frictional resistance to the rotation of said core member,

comprising the steps of:

positioning said core member on said rod member,

setting the frictional resistance to the rotation of said core member on said rod member, and

drawing an end of said roll of expandable slit sheet paper against said frictional resistance and expanding said slit sheet paper.

13- The method of claim 12, comprising an elongated member hingedly coupled to said support member and a spring, said elongated member having a threaded insert and a screw passing through said spring and into said threaded insert thereby spring loading said elongated member, and further comprising the step of variably setting said frictional resistance to the rotation of said core member by rotating said spring loaded screw and thereby varying the frictional resistance applied by an elongated member to a core member end region.

14- The method of claim 13, said rod member having four right angle corners and

received within a correspondingly dimensioned opening in said support member, said first means for securing said rod member end region to said support member securing being a threaded member releasably fastening said rod member to said support member, further comprising the steps of positioning said slit sheet paper wound on an interior core member on said rod member, rotating said threaded member in a first direction to rigidly fix said rod member to said support member, dispensing said slit sheet paper, rotating said threaded member in a second direction to release said rod member from said support member, and removing said interior core member from said rod member.

FIG 1

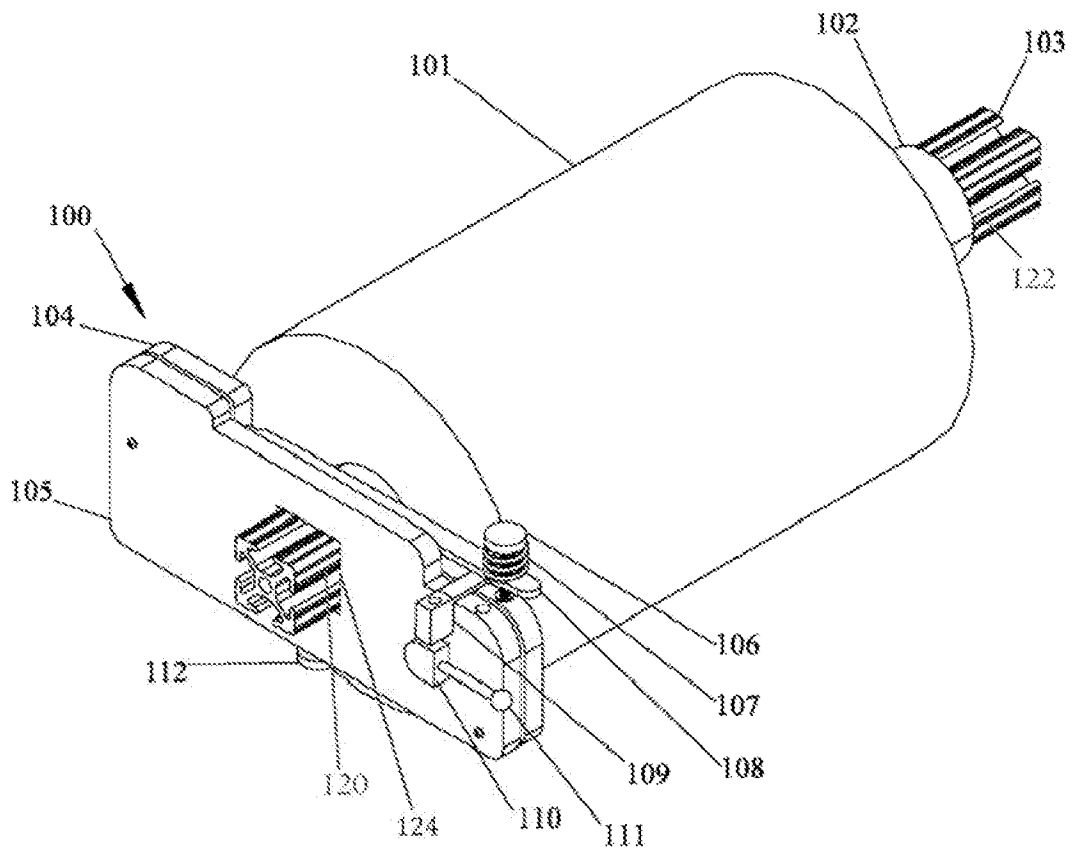

FIG 2

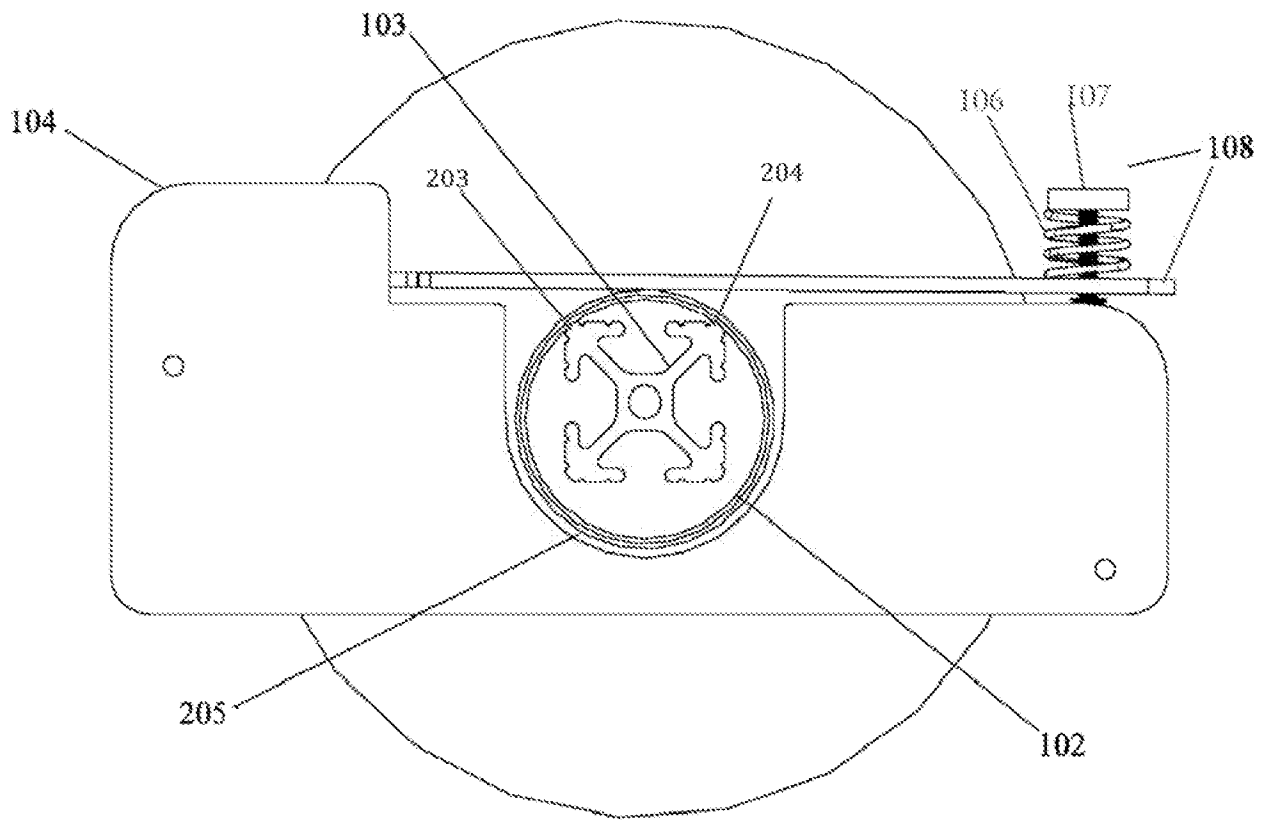

FIG 3

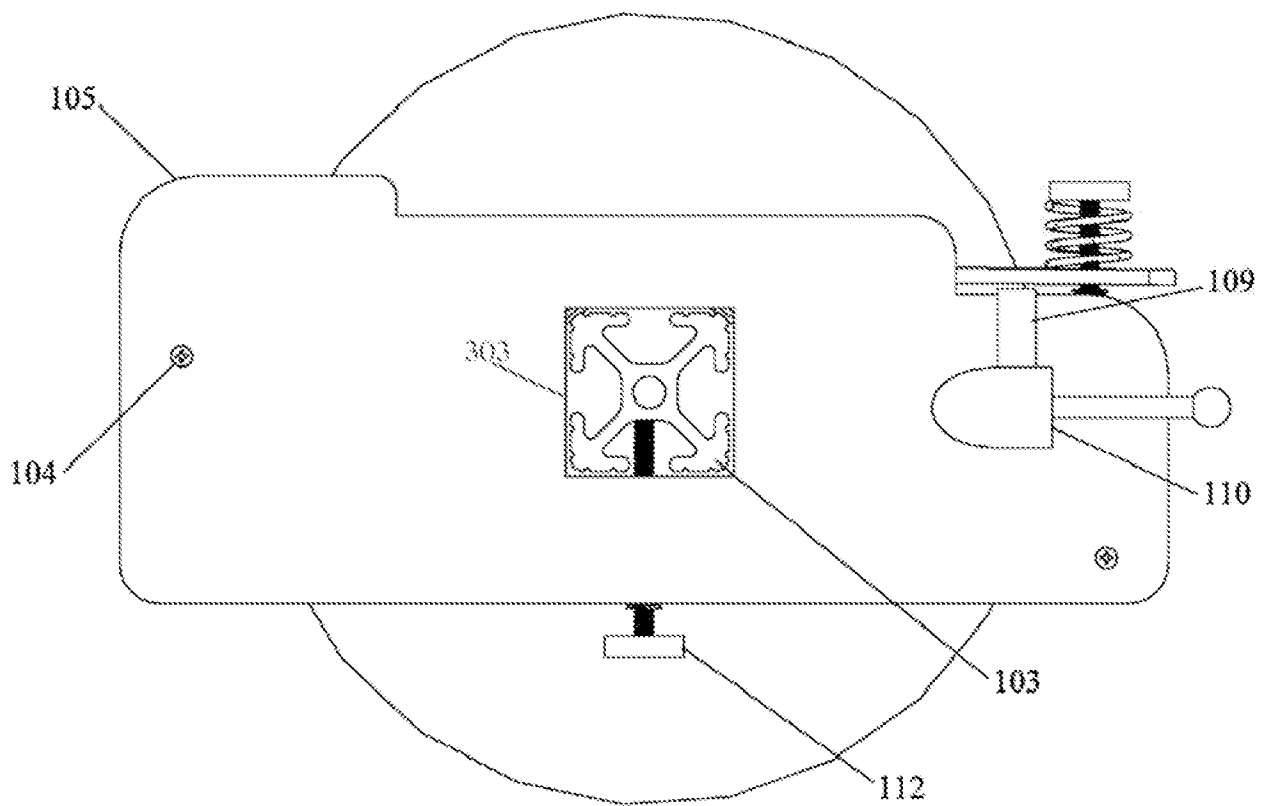

FIG 4

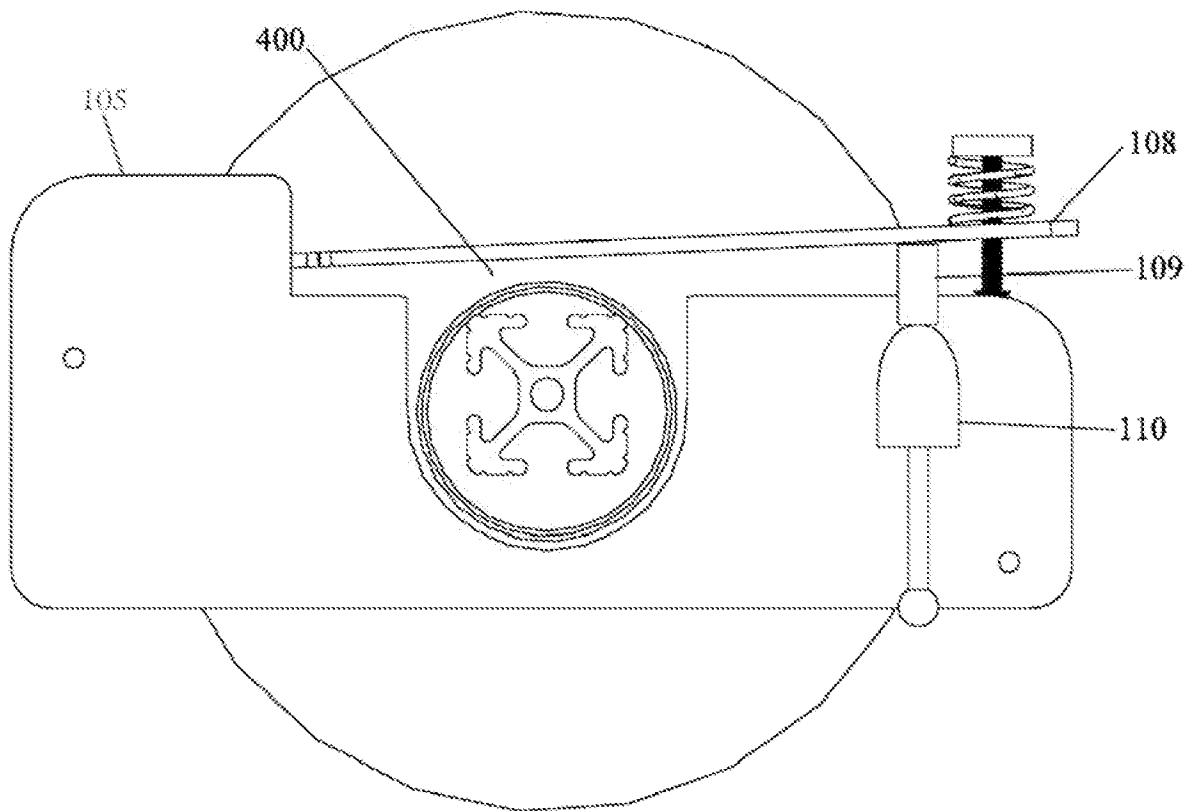

FIG 5

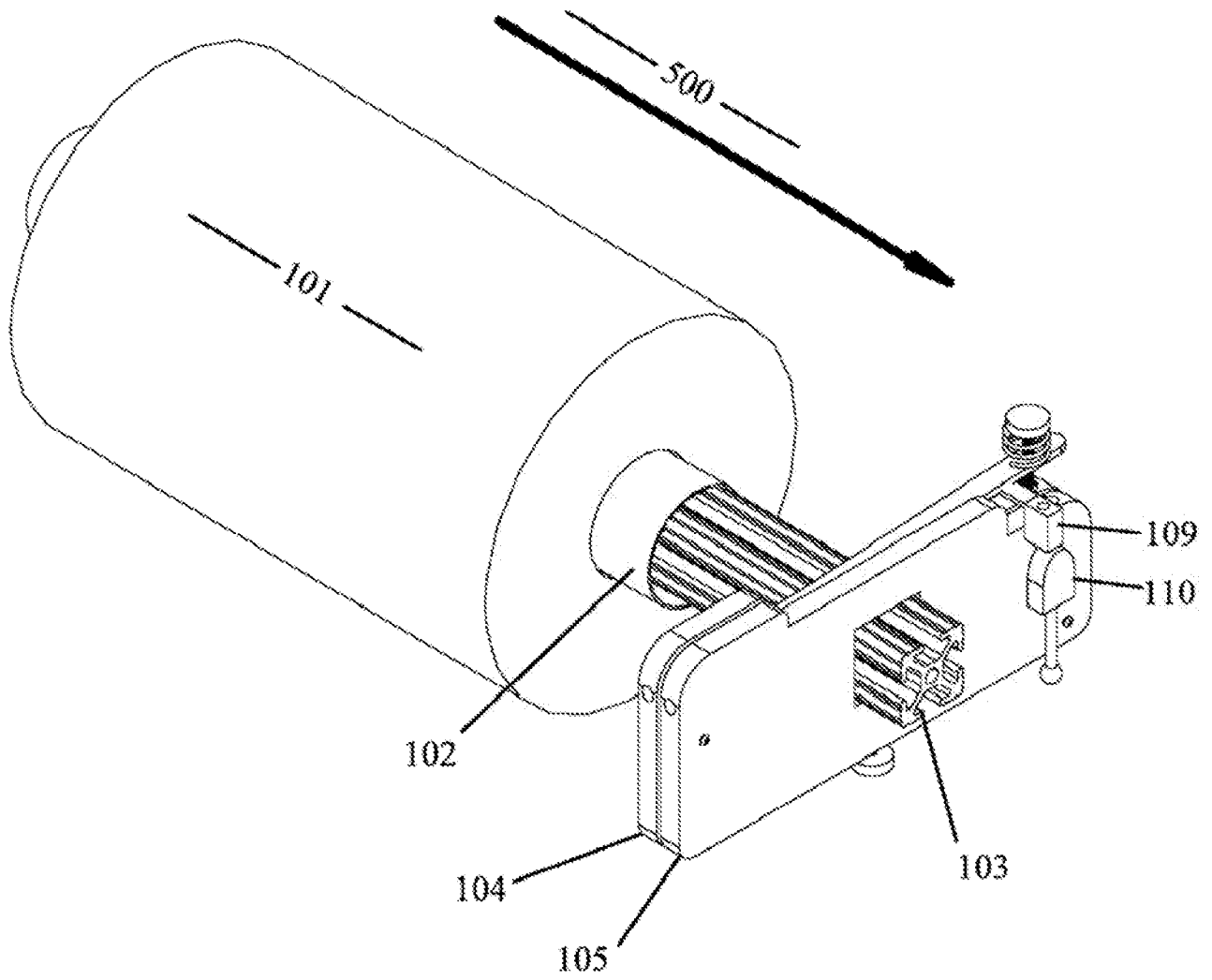

FIG 6

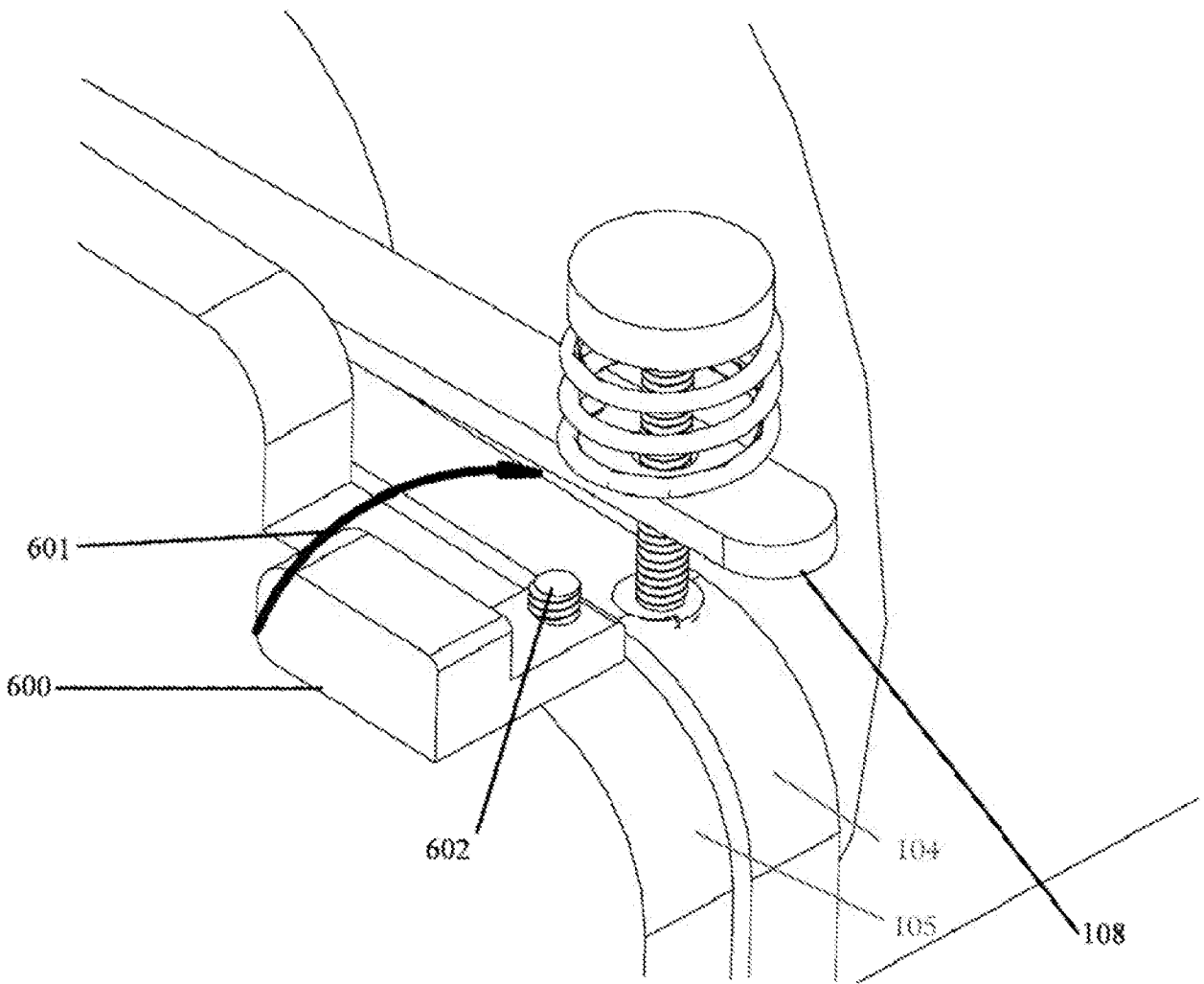

FIG 7

