



(19) **United States**

(12) **Patent Application Publication**
Emmerich et al.

(10) **Pub. No.: US 2021/0132315 A1**

(43) **Pub. Date: May 6, 2021**

(54) **OPTICAL COMMUNICATION CABLE**

(60) Provisional application No. 61/883,286, filed on Sep. 27, 2013.

(71) Applicant: **Corning Optical Communications LLC**, Charlotte, NC (US)

Publication Classification

(72) Inventors: **Michael Emmerich**, Berlin (DE); **Warren Welborn McAlpine**, Hickory, NC (US); **Guenter Wuensch**, Neustadt (DE)

(51) **Int. Cl.**
G02B 6/44 (2006.01)

(52) **U.S. Cl.**
CPC **G02B 6/4429** (2013.01); **G02B 6/4432** (2013.01); **G02B 6/4413** (2013.01); **G02B 6/4495** (2013.01); **G02B 6/443** (2013.01); **G02B 6/4433** (2013.01); **G02B 6/441** (2013.01); **G02B 6/4434** (2013.01)

(21) Appl. No.: **17/145,781**

(22) Filed: **Jan. 11, 2021**

Related U.S. Application Data

(63) Continuation of application No. 16/720,361, filed on Dec. 19, 2019, now Pat. No. 10,914,907, which is a continuation of application No. 15/073,770, filed on Mar. 18, 2016, now Pat. No. 10,539,756, which is a continuation of application No. PCT/US14/56478, filed on Sep. 19, 2014, which is a continuation of application No. 14/231,875, filed on Apr. 1, 2014, now Pat. No. 8,913,862.

(57) **ABSTRACT**

An optical communication cable is provided having a cable body with an inner surface defining a passage within the cable body and a plurality of core elements within the passage. A film surrounds the plurality of core elements, wherein the film directs a radial force inward onto the plurality of core elements to restrain and hold the plurality of core elements in place.

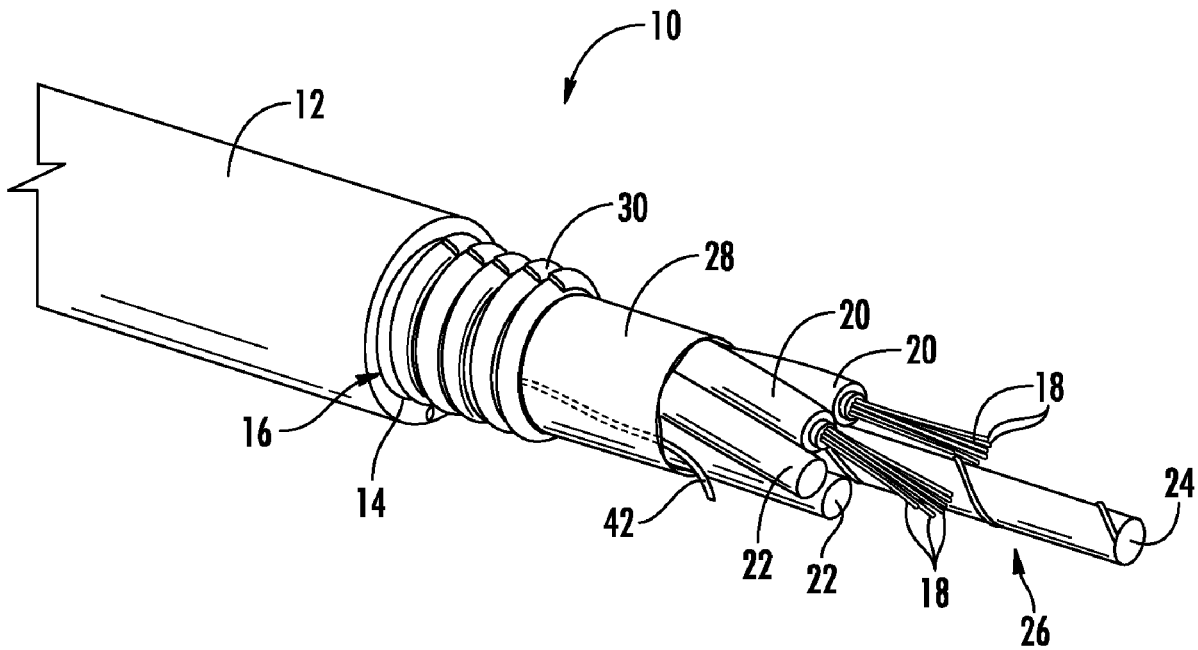

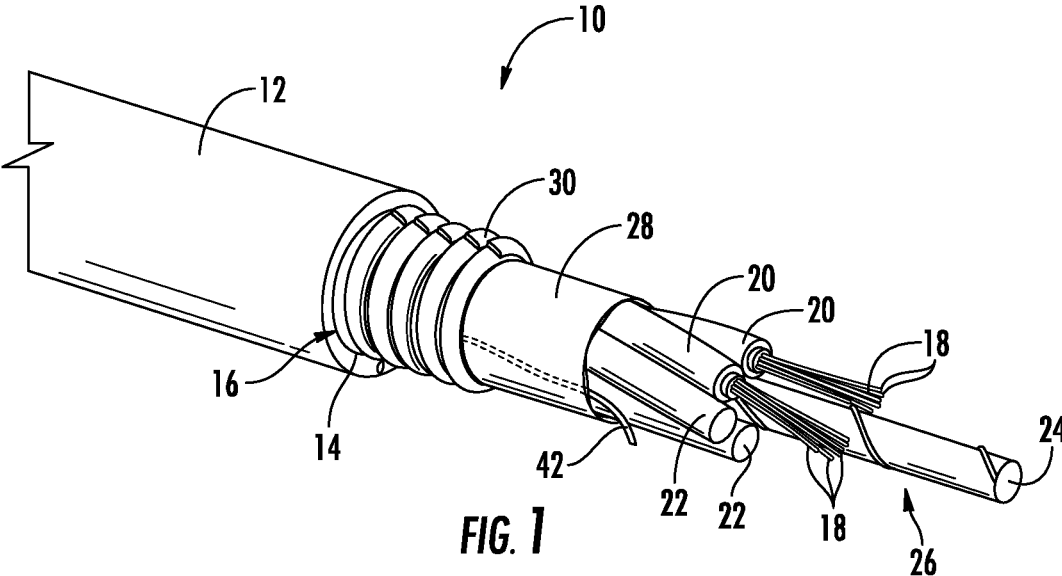

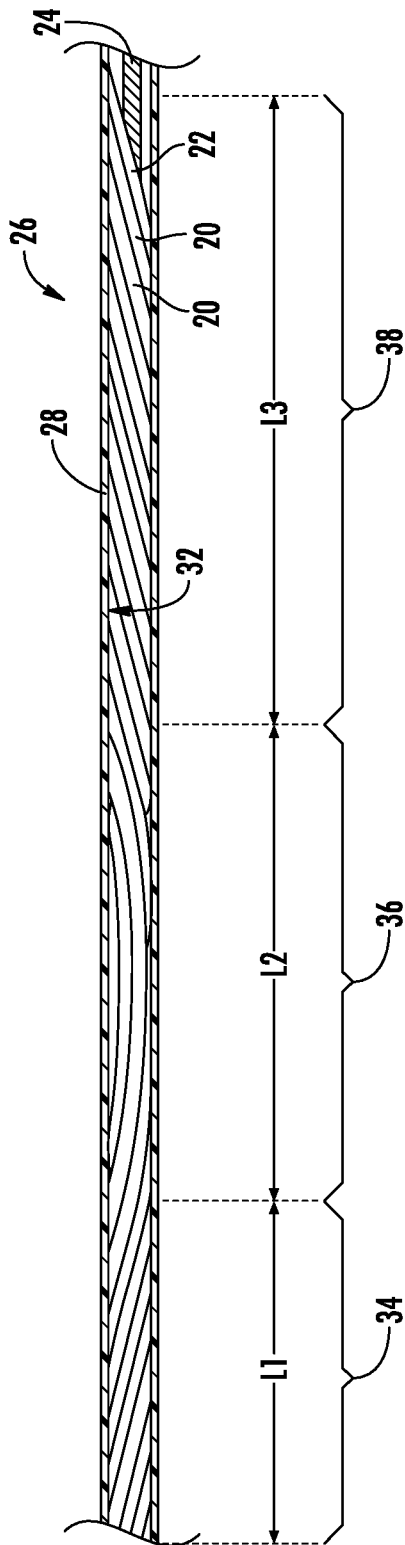

FIG. 2

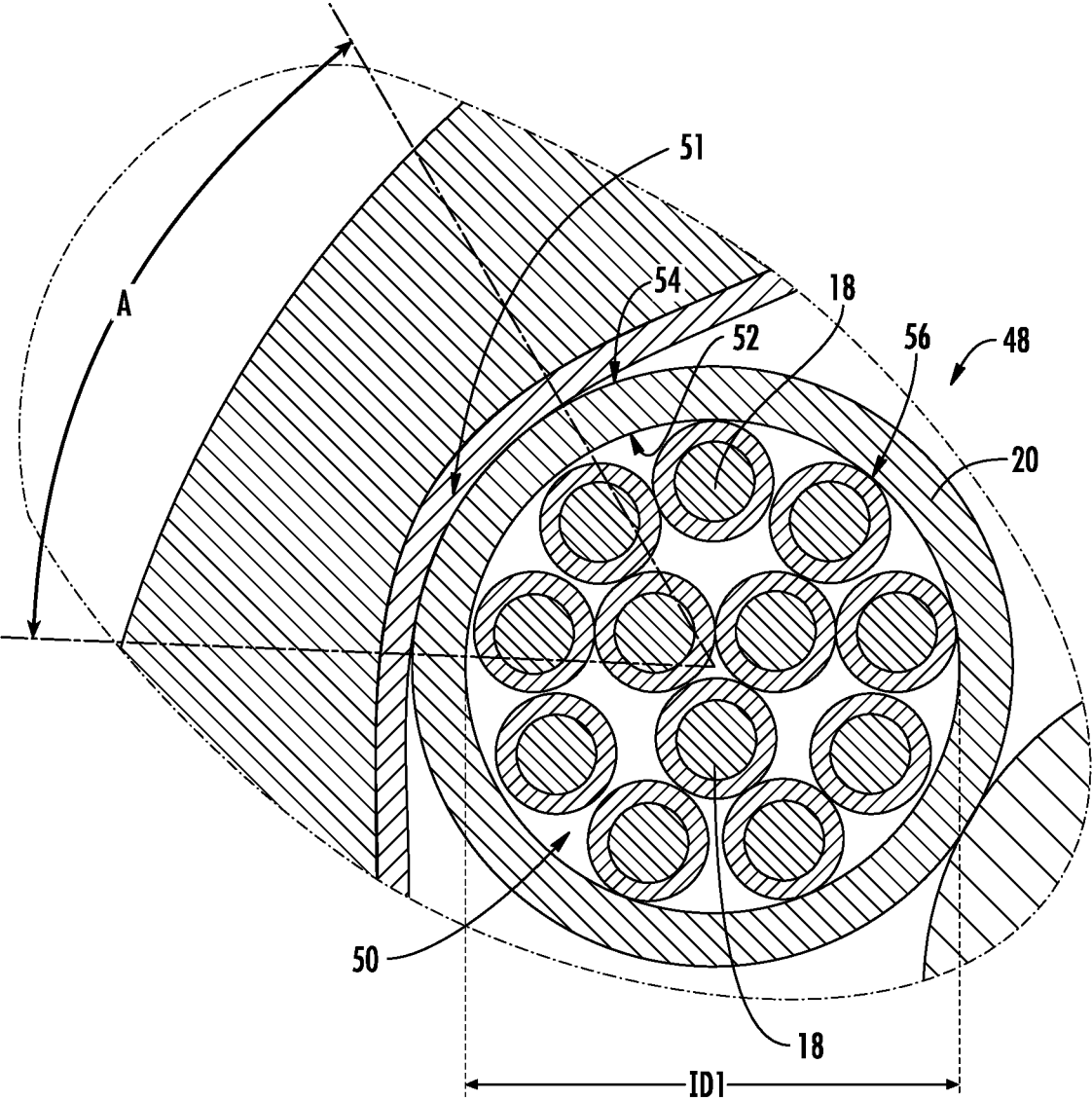

FIG. 4

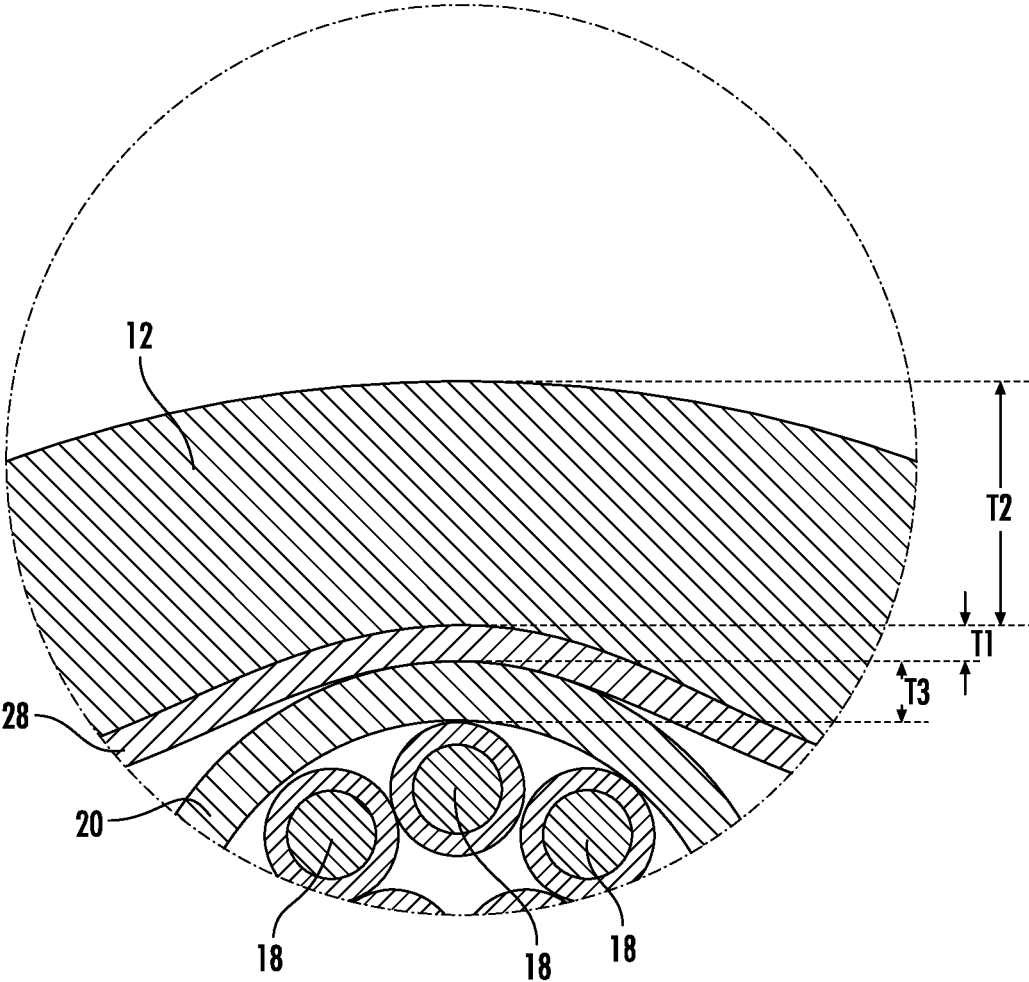

FIG. 5

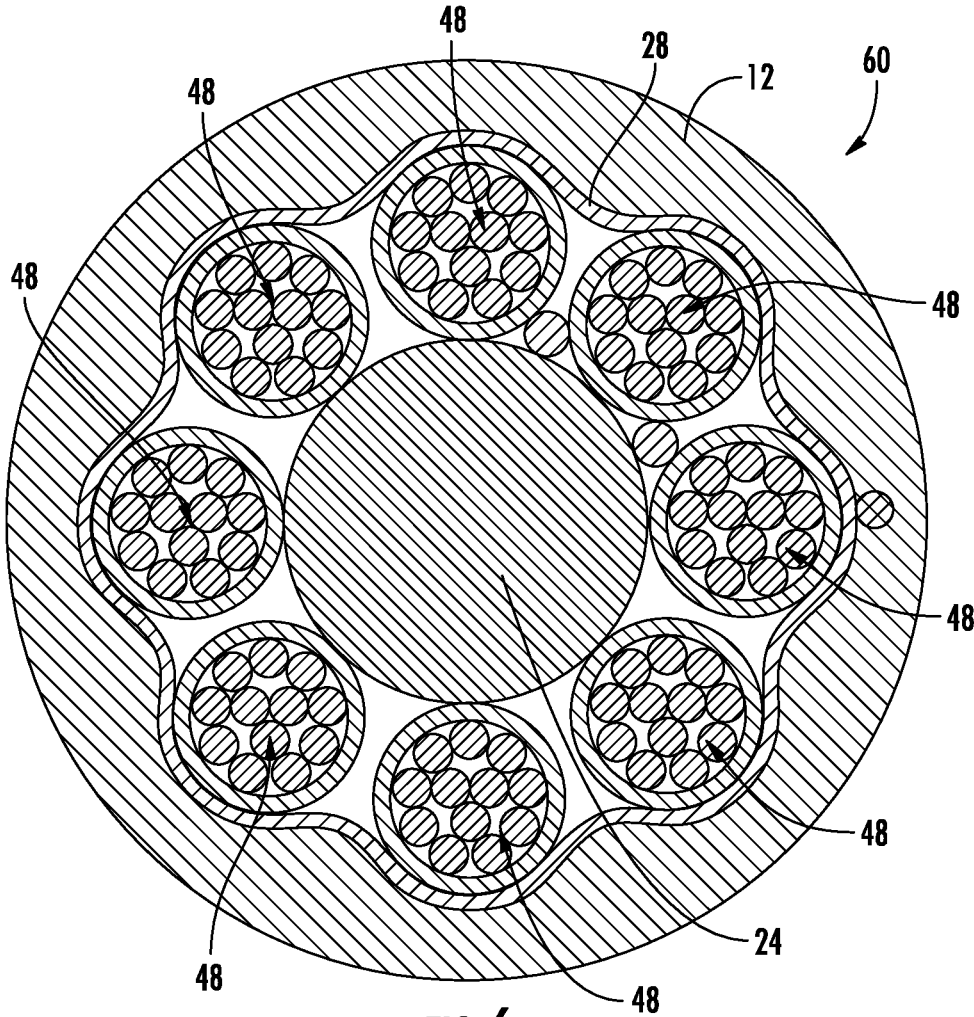

FIG. 6

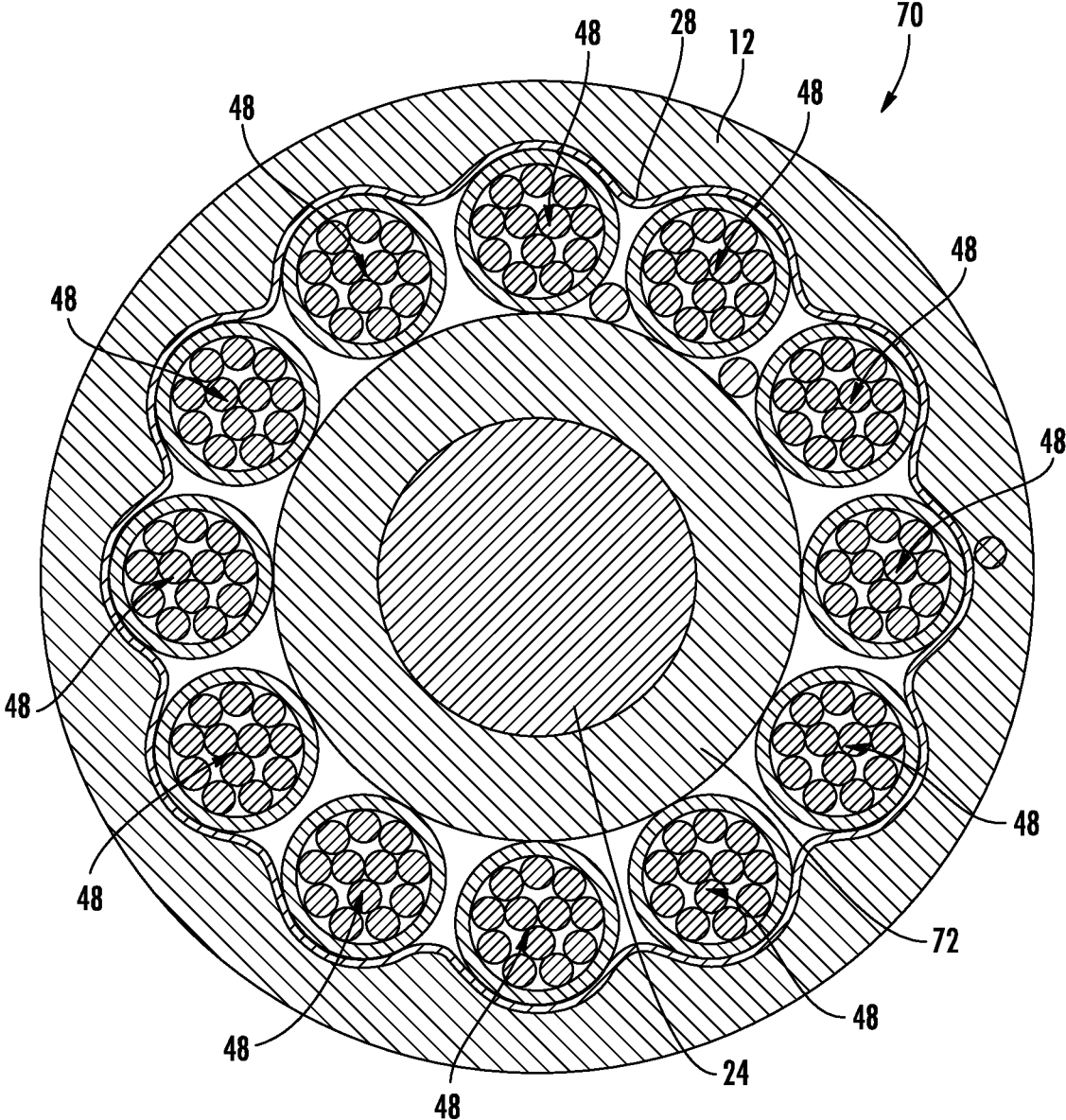
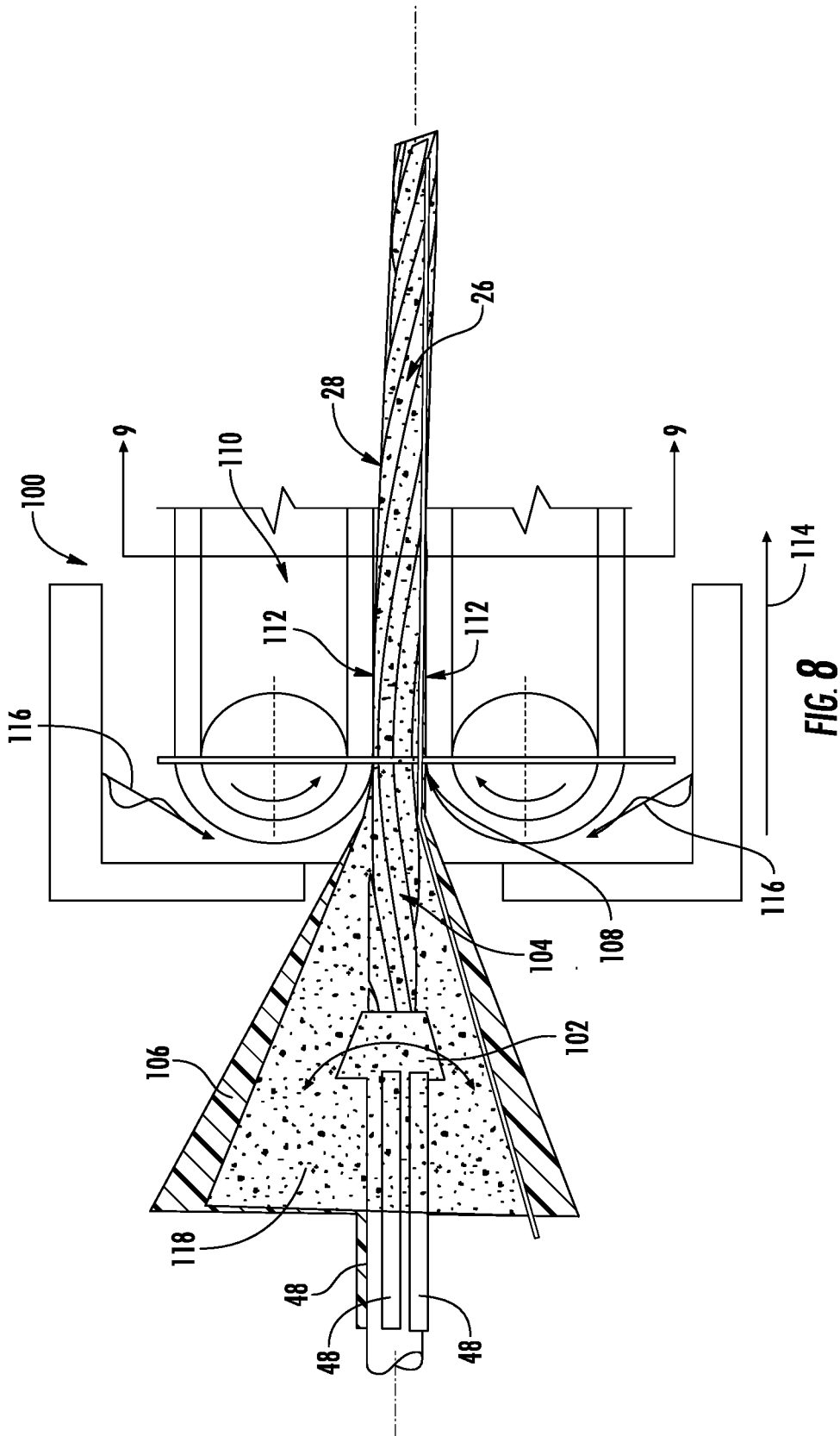

FIG. 7



OPTICAL COMMUNICATION CABLE

PRIORITY APPLICATIONS

[0001] This Application is a continuation of U.S. application Ser. No. 16/720,361, filed Dec. 19, 2019, which is a continuation of U.S. application Ser. No. 15/073,770, filed Mar. 18, 2016, now U.S. Pat. No. 10,539,756, which is a continuation of International Application No. PCT/US2014/056478, filed Sep. 19, 2014, which claims the benefit of priority of U.S. application Ser. No. 14/231,875, filed on Apr. 1, 2014, now U.S. Pat. No. 8,913,862, and U.S. Provisional Application No. 61/883,286, filed on Sep. 27, 2013, the content of each of which is relied upon and incorporated herein by reference in their entirety.

BACKGROUND

[0002] The disclosure relates generally to optical communication cables and more particularly to optical communication cables including core elements that are coupled together by a thin film prior jacket extrusion. Optical communication cables have seen increased use in a wide variety of electronics and telecommunications fields. Optical communication cables contain or surround one or more optical communication fibers. The cable provides structure and protection for the optical fibers within the cable.

SUMMARY

[0003] One embodiment of the disclosure relates to an optical communication cable. The optical communication cable includes a cable body, a first core element located in the cable body and a second core element located in the cable body. The first core element includes a first tube having an inner surface defining a bore and an outer surface and a first optical transmission element located within the bore of the first tube. The second core element includes a second tube having an inner surface defining a bore and an outer surface and a second optical transmission element located within the bore of the second tube. The optical communication cable includes a strength member located in the cable body. The first core element and the second core element are wound around the strength member. The optical communication cable includes an elastic sleeve formed from an extruded first material, and the elastic sleeve surrounds the first core element, the second core element and the strength member. The elastic sleeve includes an inner surface facing the outer surface of the first core element and the outer surface of the second core element. The cable body is formed from an extruded second material. The cable body surrounds the elastic sleeve, and the cable body has an inner surface that faces an outer surface of the elastic sleeve.

[0004] An additional embodiment of the disclosure relates to an optical communication cable. The optical communication cable includes a cable body having a passage within the cable body. The optical communication cable includes a first core element located in the passage of the cable body, and the first core element includes an outer surface and a first optical transmission element. The optical communication cable includes a second core element located in the passage of the cable body, and the second core element includes an outer surface and a second optical transmission element. The optical communication cable includes a strength member located in the passage of the cable body, and the first core element and the second core element are wound around the

strength member. The optical communication cable includes a film formed from an extruded first material located within the passage of the cable body. The film surrounds the first core element, the second core element and the strength member. The film applies a radial inwardly directed force to the outer surface of the first core element and the outer surface of the second core element. The cable body is formed from a second material different from the first material. The cable body surrounds the film, and the cable body has an inner surface that faces the outer surface of the film.

[0005] An additional embodiment of the disclosure relates to an optical communication cable. The optical communication cable includes a cable body having a bore within the cable body. The optical communication cable includes an elongate central strength member located in a central area of the bore. The optical communication cable includes a plurality of elongate optical transmission elements wrapped around the elongate central strength member such that a portion of a length of the plurality of wrapped elongate optical transmission elements forms a spiral portion around the elongate central strength member. The optical communication cable includes an extruded membrane surrounding the plurality of elongate optical transmission elements. The extruded membrane is formed from a first material, and the extruded membrane is contiguous in a circumferential direction around the elongate optical transmission elements and is contiguous in an axial direction for at least one revolution of the elongate optical transmission elements around the elongate central strength member within the spiral portion. The membrane contacts an outer surface of each of the plurality of elongate optical transmission elements within the spiral portion. The cable body is formed from an extruded second material. The cable body surrounds the film, and the cable body has an inner surface that faces the outer surface of the film.

[0006] An additional embodiment of the disclosure relates to an optical communication bundle. The optical communication bundle includes an elongate central strength member and a plurality of elongate optical transmission elements wrapped around the elongate central strength member such that a portion of the length of the plurality of wrapped elongate optical transmission elements form a spiral portion around the elongate central strength member. The optical communication bundle includes an extruded membrane surrounding the plurality of elongate optical transmission elements. The extruded membrane is contiguous in the circumferential direction around the elongate optical transmission elements and is contiguous in an axial direction for at least five revolutions of the elongate optical transmission elements around the central strength member. The extruded membrane applies a radial inwardly directed force to the outer surfaces of the plurality of elongate optical transmission elements such that the film acts to maintain the spiral arrangement of the spiral portion of the wrapped elongate optical transmission elements.

[0007] Additional features and advantages will be set forth in the detailed description which follows, and in part will be readily apparent to those skilled in the art from the description or recognized by practicing the embodiments as described in the written description and claims hereof, as well as the appended drawings.

[0008] It is to be understood that both the foregoing general description and the following detailed description

are merely exemplary, and are intended to provide an overview or framework to understand the nature and character of the claims.

[0009] The accompanying drawings are included to provide a further understanding and are incorporated in and constitute a part of this specification. The drawings illustrate one or more embodiment(s), and together with the description serve to explain principles and operation of the various embodiments.

BRIEF DESCRIPTION OF THE DRAWINGS

[0010] FIG. 1 is a perspective view of an optical fiber cable according to an exemplary embodiment.

[0011] FIG. 2 is a detailed side view showing wrapped core elements of the cable of FIG. 1 bound together via a film according to an exemplary embodiment.

[0012] FIG. 3 is a cross-sectional view of a cable according to an exemplary embodiment.

[0013] FIG. 4 is a detailed sectional view of a core element of the cable of FIG. 3 according to an exemplary embodiment.

[0014] FIG. 5 is a detailed sectional view of a portion of a core element, film and jacket of the cable of FIG. 3 according to another exemplary embodiment.

[0015] FIG. 6 is a cross-sectional view of a cable according to another exemplary embodiment.

[0016] FIG. 7 is a cross-sectional view of a cable according to another exemplary embodiment.

[0017] FIG. 8 is a schematic view showing a system and process for forming an optical cable having a thin film binder according to an exemplary embodiment.

DETAILED DESCRIPTION

[0018] Referring generally to the figures, various embodiments of an optical communication cable (e.g., a fiber optic cable, an optical fiber cable, etc.) are shown. In general, the cable embodiments disclosed herein include a thin film or membrane layer that surrounds and binds together the core elements of the cable (e.g., buffer tubes containing loose optical fibers, optical micro-modules, tight buffered optical fibers, filler rods, etc.). The film discussed herein is extruded over the core elements after the core elements are wound in a pattern or arrangement (e.g., a spiral pattern, a helical pattern, SZ pattern, etc.) around a central support member. The film is rapidly cooled and solidified around the core element such that the film contracts applying a radially inwardly directed force onto the core elements. The radial inwardly directed force increases the normal force between the core elements and the central strength element which acts to limit or prevent relative movement between the core elements and the central strength element as the elements are advanced through the cable assembly process. In addition, the radial force provided by the film acts to maintain the core elements in the wound pattern by preventing or limiting the core elements from unwinding from around the central strength member. In particular, this restraining force provided by the film maintains the core elements in the desired wound pattern as the additional components (e.g., armor material, cable jackets, etc.) are applied to form the completed cable. Thus, in various embodiments the film is an elastic sleeve that forms an interference fit with the core elements of the cable.

[0019] In various embodiments, the optical cables discussed herein include optical fiber micromodules that have low or zero extra fiber length (EFL, such as less than an average of about 0.1% or less per fiber per micromodule) within the buffer tube of the micromodules. In addition, such micromodules may include densely packed optical fibers within a buffer tube in which the inner surface of the buffer tube contacts the outer surface of one or more optical fibers within the buffer tube. The dense packing of optical fibers within the micromodules allows for smaller cross-sectional area optical units. However, the lack of EFL and the tight packing may also act to transfer external forces to the optical fibers which may result in optical signal attenuation. In contrast to helically wound binder fibers that create localized pressure points at the point of contact between the helical binder and the buffer tube, the film binder discussed herein distributes the binding forces evenly around both the circumference of the core elements and axially along the length of the core elements. In the case of micromodules that may be more susceptible to strain based attenuation, the thin film binders discussed herein may act to limit or prevent such strain based attenuation.

[0020] Referring to FIG. 1, an optical communication cable, shown as cable 10, is shown according to an exemplary embodiment. Cable 10 includes a cable body, shown as cable jacket 12, having an inner surface 14 that defines an inner passage or cavity, shown as central bore 16. As will be generally understood, inner surface 14 of jacket 12 defines an internal area or region within which the various cable components discussed below are located. A plurality of optical transmission elements, shown as optical fibers 18, are located within bore 16. Generally, cable 10 provides structure and protection to optical fibers 18 during and after installation (e.g., protection during handling, protection from elements, protection from vermin, etc.).

[0021] In the embodiment shown in FIG. 1, cable 10 includes a plurality of core elements located within central bore 16. A first type of core element is an optical transmission core element, and these core elements include bundles of optical fibers 18 that are located within tubes, such as buffer tubes 20. One or more additional core elements, shown as filler rods 22, may also be located within bore 16. Filler rods 22 and buffer tubes 20 are arranged around a central support, shown as central strength member 24 formed from a material such as glass-reinforced plastic or metal (e.g., steel). Together, buffer tubes 20 containing optical fibers 18, filler rods 22 and central strength member 24 form the core 26 of cable 10.

[0022] Cable 10 includes a film or membrane, shown as binding film 28, located around buffer tubes 20 and filler rods 22 of cable 10. As explained in more detail below, thin film 28 is an extruded thin film that cools to provide an inwardly directed force on to buffer tubes 20 and filler rods 22. The inwardly directed force provided by film 28 assists to hold buffer tubes 20 and filler rods 22 in a fixed position relative to central strength member 24 by increasing the normal force and therefore frictional force between these components. Thus, in some embodiments, an interference fit is provided between the outer surfaces of the core elements and film 28 such that film 28 acts to provide an inwardly directed force onto the core elements of cable 10. In addition, the inwardly directed force provided by film 28 acts to prevent/resist unraveling of the wound core elements. In some embodiments, an adhesive (e.g., hot melt adhesive) is

applied to couple core elements such as buffer tubes **20** and filler rods **22** to strength member **24**. Thus, in various embodiments, the film of cable **10** is a constraining element or constraining sleeve that acts to bind together the core of cable **10** as discussed herein. In specific embodiments, the film of cable **10** is an elastic sleeve that applies a radial inwardly directed force as discussed herein.

[0023] In various embodiments, film **28** is formed from a first material, and jacket **12** is formed from a second material. In various embodiments, the first material is different from the second material. In some such embodiments, the material type of the first material is different from the material type of the second material. In various embodiments, film **28** may be formed from a variety of extruded polymer materials. In various embodiments, film **28** may be formed from low-density polyethylene (LDPE), polyester, or polypropylene. In one embodiment, film **28** is formed from a linear LDPE. In one embodiment, film **28** is formed from an LDPE material having a modulus of elasticity between 600 MPa and 1000 MPa, and more specifically about 800 MPa (e.g., 800 MPa plus or minus 5 percent). In one embodiment, film **28** is formed from a polyester material having a modulus of elasticity between 2000 MPa and 2800 MPa, and more specifically about 2400 MPa (e.g., 2400 MPa plus or minus 5 percent). In various embodiments, the material of film **28** may include a coloring material. In one such embodiment, film **28** may be colored the same as jacket **12**. In one such embodiment, the material of film **28** may be a polymer material (e.g., LDPE, PP) including carbon black coloring material, and the different material of jacket **12** may be a different polymer material (e.g., medium density polyethylene) that also includes carbon black coloring material. In addition, film **28** may include UV stabilizing compounds and may include weakened areas (e.g., lower thickness areas) that facilitate tearing, for example via rip cord **42**.

[0024] As noted above, the first material of film **28** is different from the second material of jacket **12**. In some such embodiments, film **28** is formed from a first material that is extruded at an earlier time or earlier stage in cable production than jacket **12**. In such embodiments, film **28** is formed prior to formation of jacket **12**. In some such embodiments, a first extrusion process forms film **28** at an earlier time in cable production, and a second extrusion process forms jacket **12** at a later time in cable production. In some such embodiments, the first material of film **28** and the second material of jacket **12** are the same type of material (e.g., both are MDPE, PP, etc.) that are associated with cable **10** at different time points during production of cable **10**. In other embodiments, the first material of film **28** and the second material of jacket **12** are the different types of material (e.g., film **28** is a LDPE and jacket **12** is MDPE) and are also associated with cable **10** at different time points during production of cable **10**.

[0025] In contrast to a cable that includes a single outer extruded layer (e.g., a single extruded jacket), cables discussed herein including two extruded layers may include various structures not present in a cable having a single extruded layer (e.g., a single extruded outer jacket layer). For example, in some embodiments, film **28** includes an outer surface **41** that interfaces with inner surface **14** of jacket **12**. In some embodiments, cable **10** may include gaps, air pockets or delaminations between jacket **12** and film **28**. In embodiments in which the material of film **28** and jacket **12** melt or bond together during jacket extrusion, there may

be a region of mixed material including a mixture of both the material of film **28** and the material of jacket **12**. In some such embodiments, within the region of mixed material, the density of the material of film **28** increases in the radially inward direction, and the density of the material of jacket **12** increases in the radially outward direction.

[0026] In various embodiments, a layer of powder, such as water absorbing powder or particles, such as super absorbent polymer (SAP) or a water swellable gel or liquid, is located within bore **16**. In such embodiments, the inner surface of film **28** includes the water absorbent particles or other material that directly contacts the outer surfaces of buffer tubes **20** and filler rods **22** under the radial inwardly directed force applied by film **28**. In other words, as discussed herein, contact between film **28** and buffer tubes **20** and filler rods **22** may include contact through certain discontinuous intermediate or filler materials that may be present within bore **16**, such as SAP particles, SAP yarns and/or water swellable gels and liquids, that may be positioned within bore **16**. However, as discussed herein, contact between film **28** and buffer tubes **20** and filler rods **22** does not include contact through a circumferentially continuous layer of material located between film **28** and buffer tubes **20**. In some embodiments, the inner surface of film **28** directly contacts the outer surface of buffer tubes **20** such that at least a portion of the inner surface of film **28** directly physically interacts with the outer surface of the buffer tube **20** without intervening material. In one embodiment, the water blocking gel has a low gel viscosity, for example lower than 4000 mPas. In one embodiment, the SAP material may have an average polymer particle size between 5 micrometers and 20 micrometers.

[0027] In some embodiments, cable **10** includes a reinforcement sheet or layer, shown as armor layer **30**, that is located outside of film **28**. Armor layer **30** is wrapped around the interior elements (including optical fibers **18**) of cable **10** such that armor layer **30** surrounds optical fibers **18**. Armor layer **30** generally provides an additional layer of protection to fibers **18** within cable **10**, and may provide resistance against damage (e.g., damage caused by contact or compression during installation, damage from the elements, damage from rodents, etc.).

[0028] Referring to FIG. 2, optical core **26** is shown with film **28** in cross-section to show the wrap or winding pattern of buffer tubes **20** and filler rods **22** around central strength member **24**. As shown in FIG. 2, film **28** includes an inner surface **32** that extends in the axial direction in FIG. 2 (i.e., left and right in the orientation of FIG. 2) and is in contact with the radially exterior portions of the outer surfaces of buffer tubes **20** and filler rods **22** in the axial direction.

[0029] In FIG. 2, optical core **26** is shown having at least one spiral wrapped section. Specifically, optical core **26** is shown in an SZ wrapped pattern (also referred to as an SZ stranding pattern). In such embodiments, optical core **26** includes a right-handed spirally wrapped section **34**, a reversal section **36** and a left-handed spirally section **38**. Within right-handed spirally wrapped section **34**, the core elements, such as buffer tubes **20** and filler rods **22**, are wrapped spirally in the right-handed direction. Within left-handed spirally wrapped section **38**, the core elements, such as buffer tubes **20** and filler rods **22**, are wrapped spirally in the left-handed direction. Reversal section **36** is a section that provides the transition between the right-handed spirally

wrapped section 34 and the left-handed spirally wrapped section 38. In one embodiment, reversal section 36 is shaped as a sinusoidal function.

[0030] It should be understood that while FIG. 2 shows one right-handed spirally wrapped section, one reversal section and one left-handed spirally wrapped section, optical core 26 may include a large number of repeating sections similar to the sections shown in FIG. 2. In various embodiments, the right-handed spirally wrapped sections and left-handed spirally wrapped sections alternate along the length of optical core 26 with reversal sections located between each oppositely wrapped spiral section.

[0031] In addition, spirally wrapped sections include a pitch length (also known as lay length) which is the axial distance required for one of the core elements to complete a full revolution around strength member 24. In some embodiments, core 26 may have an average pitch length (or average lay length) which is the average of the multiple individual pitch lengths along the length of core 26. In various embodiments, each of sections 34, 36 and 38 have axial lengths shown as L1, L2 and L3, respectively. Generally, L1 is the length of right-handed spirally wrapped section 34 and is the distance between the reversal sections at the beginning and end of right-handed spirally wrapped section 34. L3 is the length of left-handed spirally wrapped section 38 and is the distance between the reversal sections at the beginning and end of left-handed spirally wrapped section 38. L2 is the length of reversal section 36 and generally is the distance between the beginning point and the end point of section 36. In general, the beginning point of section 36 is the point at which the pitch of right-handed spirally wrapped section 34 starts to change following section 34 moving in a direction from left to right in the orientation of FIG. 2, and the end point of section 36 is the point at which the pitch of left-handed spirally wrapped section 38 starts to change following section 38 moving in a direction from right to left in the orientation of FIG. 2.

[0032] In various embodiments, L1 and L3 are expressed in terms of the number pitch lengths that reside in the section. In other words, L1 and L3 may be expressed in terms of the number of revolutions of the core elements that are contained within each section. In various embodiments, L1 and L3 are less than 10 revolutions and more than one half revolution (i.e., less than 10 pitch lengths or lay lengths and more than one half pitch length or lay lengths). In various embodiments, L1 and L3 are between 1 revolution and 1.5 revolutions. In other embodiments, L1 and L3 are 7 revolutions, and in another embodiment, L1 and L3 are between 1 and 2 revolutions. In some embodiments, L1 and L3 are substantially the same for each right-handed spirally wrapped section 34 and each left-handed spirally wrapped section 38, respectively, along the length core 26. In other embodiments, the frequency or position of reversal 36 varies along the axis of core 26, such that L1 and L3 are different at different axial positions along core 26. In such embodiments, core 26 may have an average pitch length for the right-handed spirally wrapped section 34 and for the left-handed spirally wrapped section 38, which is the average of all pitch lengths along the length of core 26 with in each section. In various embodiments, L2 of reversal section 36 is between 45 mm and 100 mm.

[0033] In various embodiments, film 28 is positioned relative to the wrapped pattern of core 26 to restrain the core 26 from unwinding or unwrapping during cable construc-

tion. For example, in one embodiment (as shown in FIG. 8), film 28 is applied to the outer surface of core 26 immediately after the core elements are wrapped around central strength member 24 in the desired pattern. In this arrangement, film 28 holds the wrapped core 26 in the desired wrapped pattern as additional cable components (e.g., armor 30, and/or jacket 12) are applied over core 26. In another embodiment, core 26 is an optical communication bundle in which the outer surface of film 28 defines the outermost surface of the communication bundle. In such embodiments, core 26 does not include outer layers such as jacket 12.

[0034] Referring to FIG. 2, in various embodiments, film 28 is configured to provide substantially continuous contact with a portion of the outer surface of each of the core elements of core 26 for at least one pitch length within right-handed spirally wrapped section 34 and/or left-handed spirally wrapped section 38. In other embodiments, film 28 is configured to provide substantially continuous contact with a portion of the outer surface of each of the core elements of core 26 for at least five pitch lengths within right-handed spirally wrapped section 34 and/or left-handed spirally wrapped section 38.

[0035] In another embodiment, film 28 is configured to provide substantially continuous contact with a portion of the outer surface of each of the core elements of core 26 extending over at least one right-handed spirally wrapped section 34, at least one left-handed spirally wrapped section 38 and over the intervening reversal sections 36. In one such specific embodiment, film 28 is configured to provide substantially continuous contact with a portion of the outer surface of each of the elements of core 26 extending over at least ten right-handed spirally wrapped section 34, at least ten left-handed spirally wrapped section 38 and over the intervening reversal sections 36. In various embodiments, film 28 is configured to impart a radial inwardly directed force over reversal sections 36 causing inner surfaces of each of the core elements within the reversal section to engage the central strength member 24. This force may act to limit axial sliding of the core elements relative to strength member 24 during manufacture. It should be understood that contact between film 28 and the outer surfaces of core 26 includes direct contact between the inner surface 32 of film 28 and the outer surfaces of core 26, indirect contact in which particulate, gel or liquid material (such as water blocking/absorbent materials) are interspersed between core 26 and film 28, or generally any arrangement that allows the radially inwardly directed force generated by the contractive forces of film 28 to be applied to core 26.

[0036] Referring to FIG. 3, a cable 40 is shown according to an exemplary embodiment. Cable 40 is similar to cable 10 except as discussed herein. Cable 40 is shown without armor layer 30, according to an exemplary embodiment. As shown in FIG. 3, inner surface 14 of jacket 12 faces outer surface 41 of film 28. In one embodiment, as shown in FIG. 3, inner surface 14 of jacket 12 faces and directly contacts outer surface 41 of film 28. As used herein one component that directly contacts another component directly physically interacts with the component without intervening layers of material or gaps of air/space. As used herein, one component or surface that faces another component or surface is aligned with or pointed toward the component or surface and may or may not include intervening layers of material or gaps of air/space.

[0037] In various embodiments, jacket 12 is made from an extruded polymer material that is different from the extruded polymer material that forms film 28. In one such embodiment, jacket 12 is made from an extruded medium density polyethylene material, and film 28 is formed from an extruded low density polyethylene material. In one such embodiment, when the heated material of jacket 12 contacts the cooled material of film 28 during jacket extrusion, the two materials tend to melt together bonding the material of jacket 12 to film 28. In such embodiments, jacket 12 and film 28 are bonded together such that opening or removal of jacket 12 (e.g., via a rip cord) also opens or removes film 28. In other embodiments, inner surface 14 of jacket 12 faces but does not directly contact outer surface 41 of film 28, and in such embodiments, a layer, such as armor 30 is located between jacket 12 and film 28.

[0038] In various embodiments, as film 28 cools, film 28 contracts such that film 28 is in tension around buffer tubes 20 of core elements 48. In the embodiment shown, film 28 forms an undulating pattern of interspersed convex portions 49 and concave portions 51 resulting from the tension generated as film 28 cools and/or vacuum applied to the interior of film 28 during extrusion and cooling. In various embodiments, concave portions 51 of film 28 engages a portion of the outer circumference of each buffer tube 20. As shown in FIG. 4, the portion of the outer surface of buffer tube 20 engaged by concave portions 51 can be defined by angle A. In various embodiments, angle A is between 10 degrees and 90 degrees, specifically is between 20 degrees and 80 degrees and more specifically is between 30 degrees and 70 degrees. In various embodiments, angle A is greater than 10 degrees and less than 360 degrees. In addition, because of the axially continuous and circumferential continuous structure of film 28, film 28 includes concave portions 51 that engage the outer surfaces of each buffer tube 20 at each axial cross-sectional position. This structure is in contrast to a helically wound binder that engages a buffer tube tangentially and that engages discrete portions of less than all of the buffer tubes at each axial position along at least a portion of the length of cable 40.

[0039] As noted above, film 28 cools such that film 28 is in tension and applies a radially inwardly directed force onto buffer tubes 20. Thus, in various embodiments, film 28 is an elastic sleeve that surrounds core elements 48. In various embodiments, film 28 is a non-helical binder, and in such embodiments, the cables discussed herein do not include a helically wound binder located between core elements 48 and jacket 12. In such embodiments, the residual strain within film 28 following cooling is proportional to the radial force applied to buffer tubes 20. In various embodiments, because film 28 is extruded over buffer tubes 20 and cools to apply the binding force, film 28 includes low or no torsional stress and/or low or no stress in the circumferential direction. Thus, in contrast to a helically wound binder that may include both torsional stress and/or stress in the circumferential direction, film 28 may provide radial forces coupling core elements 48 to central strength member 24 without significant torsional or circumferential stress. In some embodiments, film 28 may be a non-extruded elastic sleeve imparting binding force to core elements 48 as discussed herein.

[0040] Because film 28 is continuous both circumferentially and axially along at least a portion of the axial length of core 26, at each axial cross-sectional position within film

28, the radially inwardly directed force applied by film 28 is evenly distributed circumferentially around core 26. In addition, in this arrangement, at each axial cross-section position within film 28, the coupling normal force experienced by central strength member 24 transmitted from film 28 through buffer tubes 20 is substantially evenly distributed around central strength member 24. In contrast, the coupling normal force experienced by the central strength member within in a cable using a helical binder is distributed substantially following the helical path of the binder, and thus is not evenly distributed circumferentially around the central strength member at a given axial position.

[0041] The embodiment of cable 40 shown in FIG. 3, includes six optical fiber transmission elements, shown as core elements 48, each including a buffer tube 20 and optical fibers 18. As shown the six core elements 48 are evenly spaced around central strength member 24. As discussed above, FIG. 2 shows film 28 in substantially continuous engagement with outer surfaces of the elements of core 26 in the axial direction. In addition to the axial contact, as shown in FIG. 3, film 28 is also in contact with the radial outermost surfaces of each of the core elements 48 in the circumferential direction around core elements 48. It is through both the axial contact and the circumferential contact that film 28 acts to apply a radially inward direct force that is substantially continuous in the axial and circumferential directions to maintain core 26 in the stranding pattern as discussed above.

[0042] As will be understood, the outer width between opposing sections of outer surfaces of film 28 (e.g., the cross-sectional dimension of film 28 passing through the center of bore 16) and the inner width between opposing sections of the inner surface of film 28 (e.g., the cross-sectional dimension of film 28 passing through the center of bore 16) are sized such that film 28 surrounds core elements 48 while also providing sufficient strength and tension to provide the radially inward directed force discussed above. In various embodiments, film 28 has an average outer width of between 1 mm and 10 mm.

[0043] In various embodiments, cable 40 and/or cable 10 may include various additional cable components. As shown in FIG. 1, cable 10 may include one or more rip cord 42 located between core 26 and film 28. Rip cord 42 facilitates opening of cable jacket 12 and access to the optical fibers of cable 10, and because rip cord 42 is between core 26 and film 28 it also facilitates opening of film 28. In various embodiments, the material of film 28 may be configured to not significantly bond with the material of buffer tubes 20 allowing rip cord 42 to facilitate separation of both cable jacket 12 and film 28 from buffer tubes 20. In one such embodiment, film 28 is formed from a polyethylene material, and buffer tubes 20 are formed from a material such as polypropylene or polycarbonate that does not substantially bond to the polyethylene of film 28.

[0044] Referring to FIG. 4, cable 40 may also include one or more additional elongate elements shown as elements 44 and 46. As shown in FIG. 3, elements 44 are located within bore 16 and element 46 is shown embedded in jacket 12. In one embodiment, elements 44 and 46 are elongate strength elements, and in another embodiment, elements 44 and 46 are water blocking yarns. In various embodiments, jacket 12 includes one or more co-extruded discontinuities (e.g., extruded regions of polypropylene) that extend axial through the jacket, and in such embodiments, the discontinuity

facilitates opening of jacket **12** by tearing. In one such embodiment, film **28** may be bonded to jacket **12** acting to buttress the jacket limiting the chance of accidental opening or splitting along the discontinuity. In such embodiments, film **28** may act to limit crack propagation through the material of jacket **12**.

[0045] Referring to FIG. 4, a detailed view of one of the optical transmission core elements **48** is shown according to an exemplary embodiment. As shown, each core element includes optical fibers **18** located within a bore **50** defined by inner surface **52** of buffer tube **20**. Buffer tube **20** also includes an outer surface **54** that is in contact with film **28** as discussed above. In the embodiment shown, each core element includes twelve optical fibers **18**, and in this arrangement three of the twelve optical fibers are located in a central area of bore **50**, and nine of the twelve are located around the inner three fibers and at least some of the outer nine fibers have outer surfaces **56** that engage inner surface **52** of buffer tube **20**. In various embodiments, core element **48** includes at least nine optical fibers **18** located within buffer tube **20**. In other embodiments, core element **48** of cable **40** includes 2, 4, 6, 8, 12, 24, 36 or more optical fibers **18**.

[0046] In the embodiment shown in FIG. 4, the inner diameter of buffer tube **20**, shown as ID1, is selected to provide densely packed optical fibers **18** within buffer tube **20**. In various embodiments, ID1 is between 0.5 mm and 3.0 mm. In other embodiments, ID1 is between 0.8 mm and 2.0 mm. In various embodiments, there is zero clearance between inner surface **52** of buffer tube **20** and the radially outer most surfaces of at least some fibers **18** within tube **20**. Because of the dense packing of fibers **18** within buffer tubes **20** and because of the resulting contact between fiber outer surfaces **56** and inner surface **52** of buffer tube **20**, the fibers **18** may tend to experience forces applied to outer surface **54** of buffer tube **20** which may in turn result in attenuation of the optical signal within fibers **18**. Thus, in one embodiment, use of a binding membrane, such as film **28**, in place of a typical helical tape or yarn binder, will tend to evenly distribute the binding forces both axially and circumferentially which may limit strain-based attenuation experienced by a signal with the optical fibers.

[0047] In addition, in various embodiments, fibers **18** extend between first and second opposing ends of the respective buffer tube, and in some such embodiments, the length of each fiber **18** is substantially the same length as buffer tube **20**. In these embodiments, the optical transmission element has zero or near zero excess fiber length (EFL) within the tube. In some such embodiments, the core element **48** may be referred to as a micromodules that has a cross-sectional diameter less than the diameter of a buffer tube of loose tube cable. In other embodiments, core element **48** may be a buffer tube of loose tube cable, and in such embodiments, may have an EFL greater than zero.

[0048] Referring to FIG. 5, a detailed view of film **28** and jacket **12** are shown according to an exemplary embodiment. As shown in FIG. 5, film **28** has a radial dimension or thickness shown as T1, and jacket **12** has a radial dimension or thickness shown as T2. In various embodiments, T1 is less than 100 micrometers, and T2 is greater than 1 millimeter. In various embodiments, T1 is between 25 micrometers and 75 micrometers and more specifically is about 50 micrometers. In various embodiments, T2 is between 1 millimeter and 5 millimeters, specifically is between 1

millimeter and 3 millimeters and more specifically is between 1.2 millimeters and 1.4 millimeters. In one embodiment, jacket **12** is less than 5 millimeters. In one embodiment, jacket **12** is a thin jacket, and T2 is less than or equal to 0.2 mm. In various embodiments, T1 is between 0.5% and 10% of T2, specifically T1 is between 1.5% and 6.5% of T2, and more specifically T1 is between 3.5% and 4.5% of T2.

[0049] In various embodiments, the outer diameter of jacket **12** of cable **10** is between 4 millimeters and 10 millimeters, specifically is between 5 millimeters and 6 millimeters, and more specifically is about 5.4 millimeters (e.g., 5.4 millimeters plus or minus 0.1 millimeter).

[0050] Buffer tube **20** has a radial dimension or thickness shown as T3. T3 may vary based upon the number of fibers **18** located within tube **20**. In various embodiments, T3 is between 0.2 millimeters and 0.7 millimeters, specifically is between 0.3 millimeters and 0.6 millimeters and more specifically is between 0.4 millimeters and 0.5 millimeters. In a specific embodiment, T3 is about 0.32 millimeters (e.g., 0.32 mm plus or minus 0.01 millimeters), and in another embodiment, T3 is about 0.36 millimeters (e.g., 0.36 mm plus or minus 0.01 millimeters). In various embodiments, buffer tubes **20** are formed from one or more polymer material including polypropylene (PP), polybutylene terephthalate (PBT), polycarbonate (PC), polyamide (PA), polyoxymethylene (POM), poly(ethene-co-tetrafluoroethene) (ETFE), etc.

[0051] In various embodiments, core elements **48** can include a wide variety of optical fibers including multi-mode fibers, single mode fibers, bend insensitive fibers, etc. In one embodiment, core elements **48** are micromodules of densely packed fibers within a tube. In other embodiments, core elements **48** are buffer tubes of a loose tube cable. In another embodiment, core elements **48** are tight buffered optical fibers.

[0052] Referring to FIGS. 6 and 7, different sized optical fiber cables are shown according to exemplary embodiments. As shown in FIG. 6, cable **60** is substantially similar to cable **10** discussed above, except cable **60** includes eight core elements **48**. In various embodiments, the outer diameter of jacket **12** of cable **60** is between 6 millimeters and 7 millimeters, and more specifically is about 6.4 millimeters (e.g., 6.4 millimeters plus or minus 0.1 millimeter). As shown in FIG. 7, cable **70** is substantially similar to cable **10** discussed above, except cable **70** includes twelve core elements **48**. In various embodiments, the outer diameter of jacket **12** of cable **70** is between 8 millimeters and 9 millimeters, and more specifically is about 8.2 millimeters (e.g., 8.2 millimeters plus or minus 0.1 millimeter). In addition, central strength member **24** of cable **70** includes an outer coating layer **72**. In other embodiments, cables discussed herein may include 2, 4, 10, 14, 16, 20, 24, 32, etc. core elements **48**.

[0053] Referring to FIG. 8, a schematic view of a process and system **100** for forming an SZ stranded core element surrounded by a binding film or membrane, such as film **28**, is shown according to an exemplary embodiment. An oscillating nose piece **102** wraps core elements **48** around a central strength member in a spiral pattern, such as SZ stranding pattern **104**. Nose piece **102** is located within an extruded film cone **106** that is formed as the material to form film **28** exits from the extruder. The extruded film material **106** is drawn down to closely adhere to core **26**.

[0054] As the film material 106 engages core 26, a constraining device, shown as caterpuller 110, engages the film coated core 26. Generally, caterpuller 110 engages core 26 to provide physical support to the wound core elements 48 while the material of extruded film 28 cools and solidifies. In other words, caterpuller 110 holds core elements 48 in place in the desired stranding pattern while film 28 cools and solidifies, and once film 28 is solidified, the tension within film 28 generates radial inwardly directed forces that hold core elements 48 in place in the desired stranding pattern. Caterpullers 110 also impart movement to film coated core 26 in the direction of arrow 114 to move film coated core 26 to receive other cable components including cable jacket 12 at subsequent stations in the cable assembly process. In other embodiments, system 100 may include other constraining devices, for example capstans may be used in place of caterpuller 110.

[0055] Referring to FIG. 8, system 100 is configured to accelerate the cooling of film 28 by providing an active cooling element that removes heat from the extruded material that forms film 28. In the embodiment shown system 100 is configured to direct a cooling fluid, shown as cooling fluid 116 (e.g., air, water, other coolant, etc.), on to the extruded material that forms film 28. Fluid 116 helps remove heat from film 28 accelerating the solidification process.

[0056] In various embodiments, system 100 is configured to apply SAP particles or powder 118 into the region between film 28 and core 26. In this embodiment, SAP 118 is applied to the interior of extruded film cone 106, and may be driven by a vacuum applied to the interior of extruded film cone 106. In such embodiments, SAP 118 is driven into the interstices between elements 48 within bore 16. In addition, SAP particles are embedded into the molten material of extruded film cone 106. Thus, upon solidification, film 28 is formed with embedded water blocking particles along its interior surface. In some embodiments, embedded water blocking particles are also applied to the outer surface of film 28. Thus, in such embodiments, film 28 also acts as the water blocking agent eliminating the need to add separate water blocking layers, for some cable applications.

[0057] As discussed above, as film 28 cools, film 28 contracts applying a radial inwardly directed force that is evenly distributed around core 26. Thus, film 28 acts to hold core 26 in the desired wrapped pattern while other components of the cable are added. In various embodiments, because film 28 is extruded around core 26 (as opposed to being helically wrapped) and is cooled such that the tension within film 28 acts to apply the inward binding force, film 28 does not apply significant torsional forces to core 26.

[0058] In addition to utilizing caterpuller 110 to hold core 26 in place prior to solidification of film 28, system 100 may be configured to apply an adhesive to core 26. In one such embodiment, a hot melt adhesive is applied to core 26 adjacent to nose piece 102.

[0059] In various embodiments, system 100 may be configured to perform a method of forming an optical cable. In one such embodiment, the method includes wrapping a plurality of elongate optical transmission elements around an elongate central support member. The method also includes extruding a film formed around the plurality of wrapped elongate optical transmission elements such that an inner surface of the film is in contact with an outer surface of each of the plurality of elongate optical transmission elements. The method includes cooling the film such that the

film solidifies applying a radially inwardly directed force to the plurality of elongate optical transmission elements. The method also includes extruding a cable body around the film following cooling of the film. In various embodiments, discussed above the film and jacket may be formed from the same type of material or different types of material. In various embodiments of the method, the inner surface of the film first contacts the outer surface of each of the plurality of elongate optical transmission elements within a distance of 100 mm from the point at which the elongate optical transmission elements are wrapped around an elongate central support member. In various embodiments of the method, the first material is a low density polyethylene material and the second material a medium density polyethylene material. In various embodiments, the method includes engaging an outer surface of the film after extruding the film and prior to solidification of the film. In one such embodiment, the engaging is performed by an advancing device, such as caterpuller 110.

[0060] In various embodiments, cable jacket 12 may be a variety of materials used in cable manufacturing such as medium density polyethylene, polyvinyl chloride (PVC), polyvinylidene difluoride (PVDF), nylon, polyester or polycarbonate and their copolymers. In addition, the material of cable jacket 12 may include small quantities of other materials or fillers that provide different properties to the material of cable jacket 12. For example, the material of cable jacket 12 may include materials that provide for coloring, UV/light blocking (e.g., carbon black), burn resistance, etc.

[0061] In various embodiments, the cable embodiments discussed herein may include one or more electrical conductive element located within bore 16. In various embodiments, the conductive element may be a copper conductive element having a diameter of 12 AWG, 14 AWG, 16 AWG, 18 AWG, 20 AWG, 22 AWG, 24 AWG, or smaller.

[0062] As noted above, the radially directed inwardly directed force applied by film 28 helps restrain and hold the wound core elements 48 in place during subsequent manufacturing process and also limits axially sliding that may occur between core elements and the strength element. Via pull-through testing, Applicants have found that the magnitude of the static friction force is related to the thickness of the film 28. For a polypropylene film 28 of at least 0.02 mm but less than 0.04 mm in average wall thickness, the static friction force for a 100 mm section of core elements 48 (without a jacket) is at least 10 N, such as about 12.4 N, and/or the average static friction force for a 200 mm section of core elements 48 is at least 20 N, such as about 23.1 N. Accordingly, in such embodiments, the net spring force of the core elements 48 within the reverse-oscillatory stranding pattern is about 10 N or less for a 100 mm section to prevent or limit axial migration of the core elements 48. Applicants have also found, for a polypropylene film 28 of at least 0.08 mm but less than 0.15 mm in average wall thickness, the average static friction force for a 100 mm section of stranded elements is at least 20 N, such as at least 30 N, and/or the average static friction force for a 200 mm section of stranded elements is at least 40 N, such as at least 50 N. Some testing included core elements bound by both film 28 and binders yarns to determine the contribution of the film 28.

[0063] While the specific cable embodiments discussed herein and shown in the figures relate primarily to cables and core elements that have a substantially circular cross-sectional shape defining substantially cylindrical internal bores,

in other embodiments, the cables and core elements discussed herein may have any number of cross-section shapes. For example, in various embodiments, cable jacket **12** and/or buffer tubes **20** may have an oval, elliptical, square, rectangular, triangular or other cross-sectional shape. In such embodiments, the passage or lumen of the cable or buffer tube may be the same shape or different shape than the shape of cable jacket **12** or buffer tube. In some embodiments, cable jacket **12** and/or buffer tube may define more than one channel or passage. In such embodiments, the multiple channels may be of the same size and shape as each other or may each have different sizes or shapes.

[0064] The optical transmission elements discussed herein include optical fibers that may be flexible, transparent optical fibers made of glass or plastic. The fibers may function as a waveguide to transmit light between the two ends of the optical fiber. Optical fibers may include a transparent core surrounded by a transparent cladding material with a lower index of refraction. Light may be kept in the core by total internal reflection. Glass optical fibers may comprise silica, but some other materials such as fluorozirconate, fluoroaluminate, and chalcogenide glasses, as well as crystalline materials, such as sapphire, may be used. The light may be guided down the core of the optical fibers by an optical cladding with a lower refractive index that traps light in the core through total internal reflection. The cladding may be coated by a buffer and/or another coating(s) that protects it from moisture and/or physical damage. These coatings may be UV-cured urethane acrylate composite materials applied to the outside of the optical fiber during the drawing process. The coatings may protect the strands of glass fiber.

[0065] In some embodiments, as disclosed above, the binding element (e.g., sleeve, film, membrane) and/or the jacket of the respective cable may include, such as primarily include or is formed from, polyethylene. In some such embodiments, the polyethylene may be high-density polyethylene having a density about 0.93 to 0.97 g/cm³. In some embodiments, the buffer tubes include polycarbonate, as discussed above, and may further include an exterior and/or interior layer of another polymer, such as polybutylene terephthalate or polypropylene, which may serve to limit or mitigate crack initiation or propagation through the polycarbonate.

[0066] The following are specific examples of cables as disclosed herein.

EXAMPLE 1

[0067] One embodiment includes a cable having six tubes positioned around a glass-reinforced plastic strength member. The strength member may have a diameter of about 1.5 mm. The tubes may be polypropylene or a composite of a polycarbonate inner layer with polybutylene terephthalate outer layer. The tubes may have an outer diameter of 1.4 mm, 1.3 mm, or 1.1 mm. The tubes may each include twelve optical fibers. Additionally, the cable includes two water-blocking yarns wrapped around the strength member, such about 1100 dtex in fineness of the yarn. The cable includes a stranding lay length or pitch length, as discussed above, in the range of between about 56 to 60 mm. Further, the core includes a binding element, as disclosed herein, and possibly includes one or more ripcords to remove the binding element and/or the jacket. The core has an outer diameter of about 4.4 mm. The jacket is formed from high-density polyethylene,

has a thickness of about 0.5 mm, and may be colored black. The resulting outer diameter of the cable is about 5.3 mm.

EXAMPLE 2

[0068] Another embodiment includes a cable having eight tubes positioned around a glass-reinforced plastic strength member. The strength member may have a diameter of about 2.5 mm. The tubes may be polypropylene or a composite of a polycarbonate inner layer with polybutylene terephthalate outer layer. The tubes may have an outer diameter of 1.4 mm, 1.3 mm, or 1.1 mm. The tubes may each include twelve optical fibers. Additionally, the cable includes two water-blocking yarns wrapped around the strength member, such about 1100 dtex in fineness of the yarn. The cable includes a stranding lay length or pitch length, as discussed above, in the range of between about 66 to 70 mm. Further, the core includes a binding element, as disclosed herein, and possibly includes one or more ripcords to remove the binding element and/or the jacket. The core has an outer diameter of about 5.4 mm. The jacket is formed from high-density polyethylene, has a thickness of about 0.5 mm, and may be colored black. The resulting outer diameter of the cable is about 6.3 mm.

EXAMPLE 3

[0069] Another embodiment includes a cable having twelve tubes positioned around a glass-reinforced plastic strength member. The strength member may have a diameter of about 2.5 mm or 4.3 mm. The tubes may be polypropylene or a composite of a polycarbonate inner layer with polybutylene terephthalate outer layer. The tubes may have an outer diameter of 1.4 mm, 1.3 mm, or 1.1 mm. The tubes may each include twelve optical fibers. Additionally, the cable includes two water-blocking yarns wrapped around the strength member, such about 1100 dtex in fineness of the yarn. The cable includes a stranding lay length or pitch length, as discussed above, in the range of between about 80 to 84 mm. Further, the core includes a binding element, as disclosed herein, and possibly includes one or more ripcords to remove the binding element and/or the jacket. The core has an outer diameter of about 7.2 mm. The jacket is formed from high-density polyethylene, has a thickness of about 0.5 mm, and may be colored black. The resulting outer diameter of the cable is about 8.1 mm.

[0070] In contemplated embodiments, cables similar to the above described examples and other embodiments disclosed herein, may include at least four tubes carrying optical fibers and/or no more than twenty tubes, such as at least six and/or no more than eighteen tubes. In contemplated embodiments, the central strength member of any one of the above examples may include steel or even stranded stainless steel, such as a steel rod up-jacketed with polyethylene insulator. In contemplated embodiments, the central strength member is at least about 1.25 mm in diameter and/or no more than about 5 mm in diameter. In some contemplated embodiments, even smaller tubes are used than those described in the examples, such as tubes having an outer diameter of about 1 mm or less, where the tubes may still include twelve optical fibers, but the optical fibers may have smaller diameters than typical optical fibers, such as diameters as small as 210 micrometers or less, such as about 200 micrometers in diameter. In some embodiments, 1 mm tubes or other size tubes as disclosed herein may include fewer optical fibers than twelve, such as 8 or less optical fibers, or 4 or less

optical fibers. In other contemplated embodiments, larger tubes may be used, such as tubes that are greater than 1.4 mm in diameter and less than about 2 mm in diameter, where such tubes may carry more than twelve optical fibers and/or no more than a hundred optical fibers, such as twenty-four optical fibers of about 200 micrometers in diameter within a 1.7 mm tube. In some contemplated embodiments, the cables may not include water-blocking yarn, or may use other sizes or numbers of water-blocking yarn. In some contemplated embodiments, the lay or pitch length of the stranding is at least about 50 mm and/or no more than about 100 mm. In contemplated embodiments, such as those similar to the above examples and embodiments disclosed above, the core has an outer diameter that is at least about 3 mm and/or no more than about 10 mm, such as at least about 4 mm and/or no more than about 9 mm. In contemplated embodiments, the wall thickness of the jacket is at least 0.3 mm and/or no more than 0.8 mm. The material of the jacket may be any type of polyethylene, or may be a flame-retardant material, such as filled polyvinyl chloride or a low-smoke-zero-halogen material. The jacket may be orange, green, or otherwise colored. The resulting outer diameter of contemplated cables disclosed herein is at least 4 mm and/or no greater than about 12 mm, such as at least about 5 mm and/or no greater than about 10 mm. The above disclosure may allow for a particular narrow minicable, able to be routed in small ducts and consuming little space.

[0071] Unless otherwise expressly stated, it is in no way intended that any method set forth herein be construed as requiring that its steps be performed in a specific order. Accordingly, where a method claim does not actually recite an order to be followed by its steps or it is not otherwise specifically stated in the claims or descriptions that the steps are to be limited to a specific order, it is in no way intended that any particular order be inferred. In addition, as used herein the article “a” is intended include one or more than one component or element, and is not intended to be construed as meaning only one.

[0072] It will be apparent to those skilled in the art that various modifications and variations can be made without departing from the spirit or scope of the disclosed embodiments. Since modifications combinations, sub-combinations and variations of the disclosed embodiments incorporating the spirit and substance of the embodiments may occur to persons skilled in the art, the disclosed embodiments should be construed to include everything within the scope of the appended claims and their equivalents.

What is claimed is:

1. A method of forming an optical cable assembly, the method comprising:

stranding a plurality of core elements via an oscillating nosepiece;

extruding a film around the stranded core elements via an extruder, wherein the oscillating nosepiece is located

within an extruded film cone that is formed as material to form the film exits from the extruder;

engaging the stranded core elements coated with the film with a constraining device to provide physical support to the wound core elements while the extruded film cools and solidifies, wherein the film directs a radial force inward onto the plurality of core elements to restrain and hold the plurality of core elements in place.

2. The method of claim 1, wherein when an average wall thickness of the film is at least 0.02 millimeters but less than 0.04 millimeters a static friction force is at least 10 N for a 100 millimeter section of the stranded core elements and is at least 20 N for a 200 millimeter section of the stranded core elements; and wherein when the average wall thickness of the film is at least 0.08 millimeters but less than 0.15 millimeters the static friction force is at least 20 N for the 100 millimeter section of the stranded core elements and is at least 40 N for the 200 millimeter section of the stranded core elements.

3. The method of claim 1, further comprising: directing a cooling fluid onto the extruded material that forms the film to help remove heat from the film and accelerate a solidification process.

4. The method of claim 1, further comprising: applying a hot melt adhesive to the stranded core elements.

5. The method of claim 1, further comprising: applying SAP particles or powder to an interior of the extruded film cone.

6. The method of claim 1, wherein the plurality of core elements comprises a plurality of tubes, each tube having an inner surface defining a bore and an outer surface. The method of claim 6, wherein the tubes are stranded around a strength element.

8. The method of claim 1, wherein when the average wall thickness of the film is at least 0.02 millimeters but less than 0.04 millimeters, a net spring force of the stranded core elements is about 10 N or less for the 100 millimeter section.

9. The method of claim 6, wherein each tube contains a plurality of optical transmission elements.

10. The method of claim 1, wherein the film is a polypropylene film.

11. The method of claim 1, wherein at least one of core elements comprises one or more electrically conductive elements.

12. The method of claim 11, wherein the conductive elements include a copper conductive element having a diameter of 12 AWG, 14, AWG, 18 AWG, 20 AWG, 22 AWG, 24 AWG, or smaller.

13. The method of claim 9, wherein each tube comprises a bore having a diameter of between 0.5 mm and 3.0 mm, and wherein the optical transmission elements in the tubes have EFL of about 0.1% or less per optical transmission element on average.

* * * * *