

(No Model.)

3 Sheets—Sheet 1.

N. FRASER.

METHOD OF PLAINTING AND MACHINERY THEREFOR.

No. 369,514.

Patented Sept. 6, 1887.

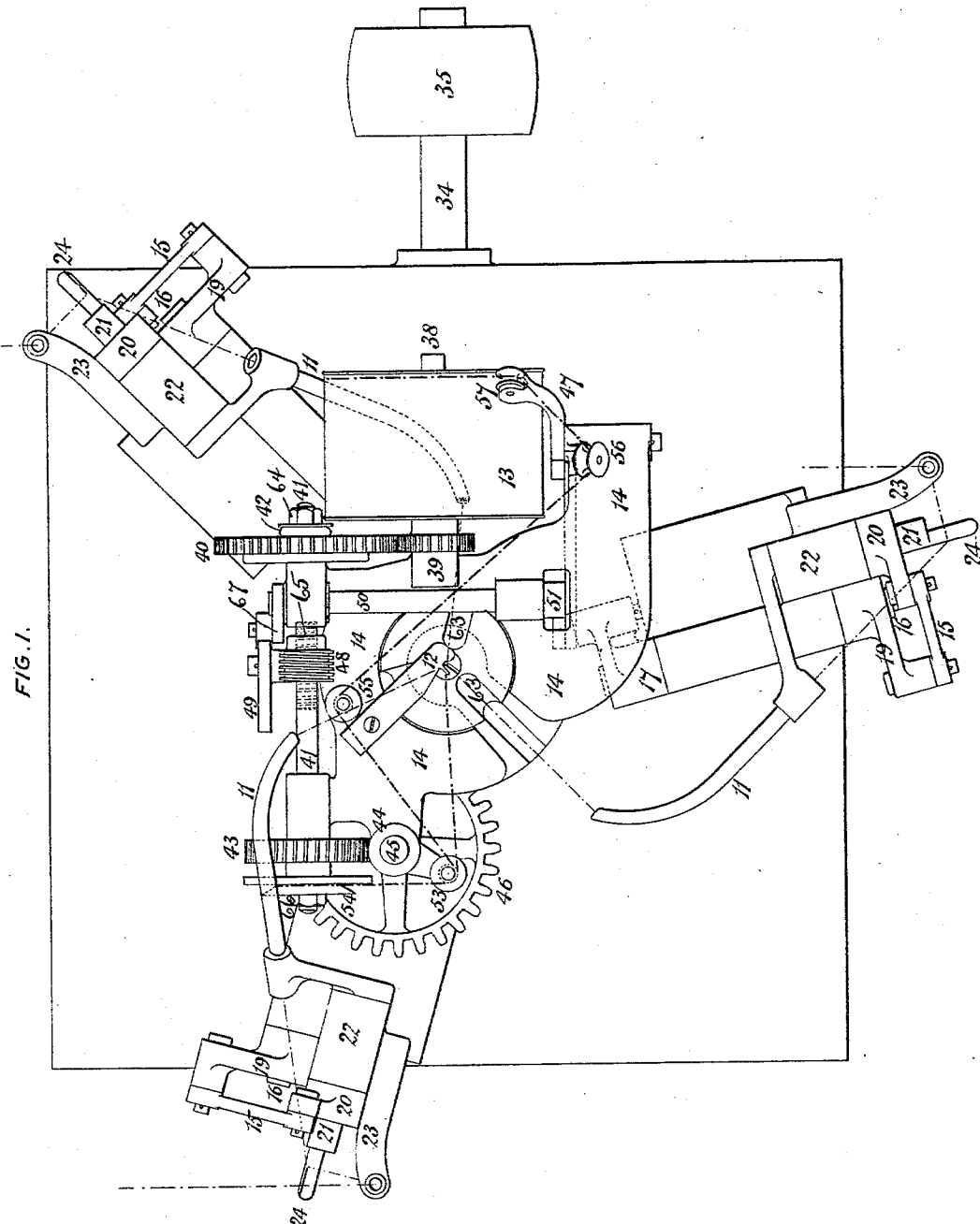

FIG. 1.

Witnesses:
David S. Williams,
William D. Corner

Inventor:
Norman Fraser
by his Attorneys
Howson & Sons

N. FRASER.

METHOD OF PLAITING AND MACHINERY THEREFOR.

No. 369,514.

Patented Sept. 6, 1887.

FIG. 2.

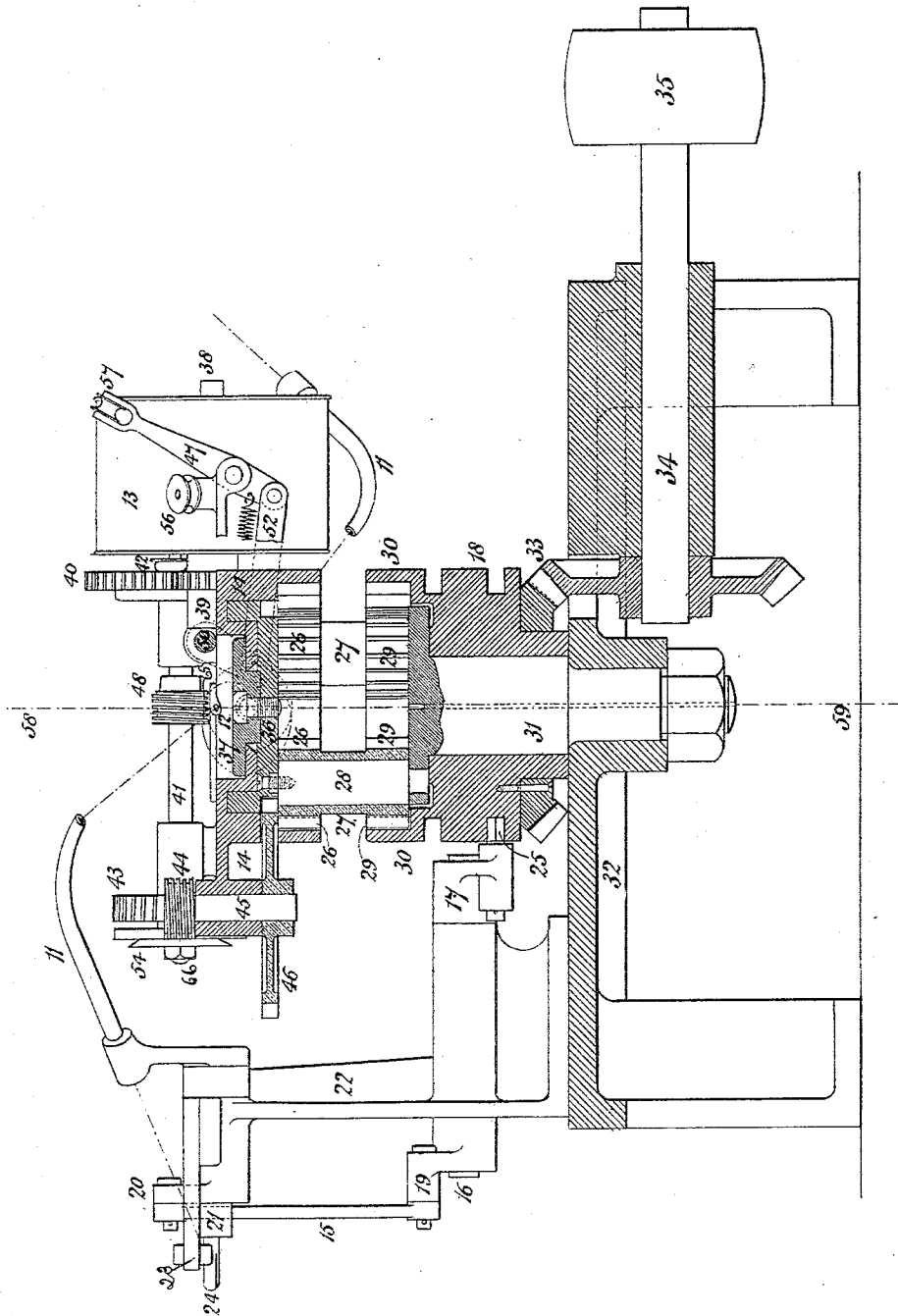

Witnesses:
David Williams
William D. Coover

Inventor:
Norman Fraser
 by his Attorneys
Howson & Son

N. FRASER.

METHOD OF PLAITING AND MACHINERY THEREFOR.

No. 369,514.

Patented Sept. 6, 1887.

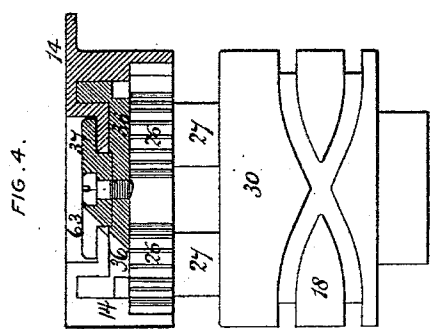
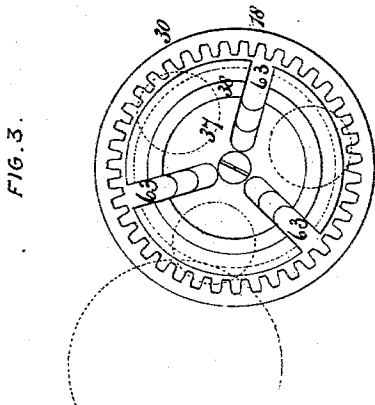
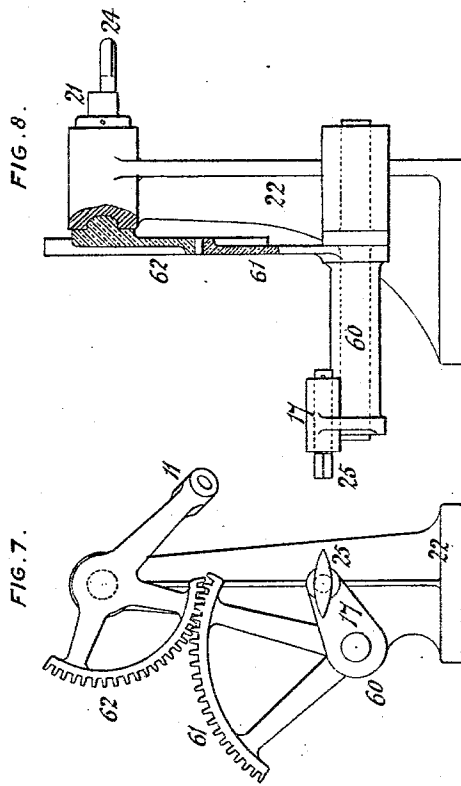
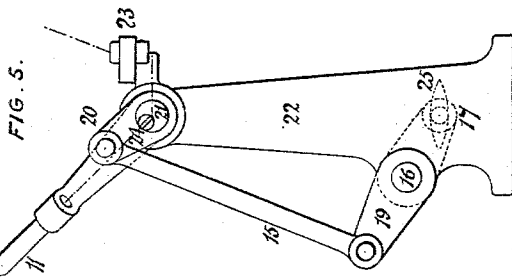
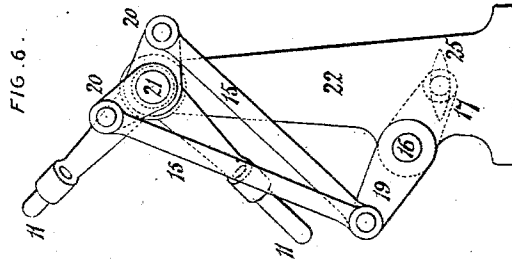

Witnesses:
David S. Williams.
William D. Connor

Inventor:
Norman Fraser
 by his Attorneys
Howson & Co.

UNITED STATES PATENT OFFICE.

NORMAN FRASER, OF ARBROATH, COUNTY OF FORFAR, SCOTLAND.

METHOD OF PLAITING AND MACHINERY THEREFOR.

SPECIFICATION forming part of Letters Patent No. 369,514, dated September 6, 1887.

Application filed May 11, 1886. Serial No. 201,794. (No model.) Patented in England June 16, 1881, No. 2,632, and November 11, 1885, No. 13,713; in France December 9, 1881, No. 146,431 and May 7, 1886, No. 175,981; in Germany December 29, 1881, No. 22,064; in Spain May 3, 1882, No. 2,608, April 23, 1885, No. 4,601, and November 17, 1886, No. 5,972, and in Italy May 3, 1883, No. 15,181.

To all whom it may concern:

Be it known that I, NORMAN FRASER, a subject of the Queen of Great Britain and Ireland, and residing at Arbroath, county of Forfar, Scotland, have invented a certain Method of Plaiting and Machinery Therefor, (for part of which improvements I have obtained British Letters Patent No. 2,632, dated June 16, 1881; French Patent No. 146,431, December 9, 1881; German Patent No. 22,064, December 29, 1881; Spanish Patent No. 2,608, May 3, 1882; Italian Patent No. 15,181, May 3, 1883; Spanish Importation Patent No. 4,601, April 23, 1885, while for other parts I have obtained British Patent No. 13,713, November 11, 1885; French Patent No. 175,981, and Spanish Patent, dated November 17, 1886, No. 5,972,) of which the following is a specification.

My said invention comprises an improved mode of and machinery for plaiting fibrous or other flexible materials—such as strands, threads, yarns, slivers, bands, or wires—and is applicable for forming the simplest triple or three-end plait, or for plaiting more than three strands or ends together.

In the ordinary way of forming a triple plait the plaited part is held and the plaiting is continued by manipulating or moving the strands or ends so as to interlace them, and when the ends are long it is usual to have them wound on bobbins, which are moved about by hand or by means of machinery. In carrying out the present invention, however, the separate ends are held instead of being free, (although of course fed forward as the work proceeds,) and the plaiting is done by a movement imparted to the plaited part, (or at the commencement of the work to the knot uniting the inner ends of the three strands.) If the three strands are distended horizontally, so as to radiate from a knot uniting them, and if the knot is passed alternately under and over the strands in regular rotation—that is, under one, over the second, under the third, over the first, under the second, and so on—it will be found that the required plait is produced.

The details of the machinery to be used for carrying out my invention may be constructed

or arranged in various ways; but the method consists in passing the plaited material in rotation over and under the several strands or ends, and for this purpose devices are provided to move or traverse the plait-receiver in an annular course, in combination with devices to move the strands or ends across the path of the traversing plait-receiver. In other words, instead of having the plait-receiver stationary, or having it rise and fall to carry the plait over and under the strands or ends, these latter are suitably raised or lowered, just as warps are when shed in a loom, to allow the shuttle to pass through them. This method of plaiting and machinery for carrying it out are described in the above-mentioned British patent granted to me under date of June 16, 1881, No. 2,632; but I prefer to use the detailed construction of machinery which is set forth in my later British Patent No. 13,713, dated November 11, 1885, and which I will now proceed to describe.

In the accompanying drawings, Figure 1 is a plan view of the machinery. Fig. 2 is a vertical section of the same. Fig. 3 is a plan view of a part detached. Fig. 4 is a side view, partly in section, of parts separated from the machine. Fig. 5 is a view of the devices for operating the yarn-guides. Fig. 6 is a view of a modification, and Figs. 7 and 8 are views of another modification.

The machinery shown in Figs. 1 and 2 is constructed for plaiting together three strands, each strand consisting of a single thread or of any number of threads. The strands are led through guide-tubes 11 to a central guide-eye, 12, and the plaiting is effected by vibrations of these guide-tubes 11, combined with the continuous revolution about a vertical axis of the plait-receiver or, as it has been termed, the "shuttle," (because of its passing alternately over and under the strands, like the shuttle of an ordinary loom, passing alternately over and under the warp-threads.) The plait-receiver or shuttle of the plaiting-machine does not, however, deliver weft like a weaving-shuttle, but, on the contrary, receives the combined strands as they become plaited together, being provided with mechanism for taking up the

plaited material as it is produced. In the machinery shown in the drawings, a bobbin, 13, is provided, upon which the plaited material is taken up, and because of this the shuttle does not require to be in the form of a box or hollow casing, such as is shown in my earlier British patent, hereinbefore referred to. The traveling plait-receiver or shuttle I prefer to make in the form of a plate, 14, carrying the bobbin 13, the central guide-eye piece, 12, and the take-up gearing, which will be hereinafter described.

In carrying out the present invention, the guide tubes or arms 11, which lead the strands alternately above and below the shuttle-plate 14, which receives the plaited material and moves on a circular race or guide, are worked by rods 15, connecting them to the radial rocking shafts 16. These rock-shafts have crank-arms 17 at their inner ends, acted on by a cylindrical grooved cam, 18, Fig. 4, concentric with the central vertical axis of the machine. The rods 15 have their lower ends jointed on crank-arms 19 on the outer ends of the radial rocking shafts 16, and their upper ends are jointed to crank-arms 20 on rocking shafts 21, on which the guide tube or arms 11 are fixed.

The upper and lower rocking shafts, 21 16, for each guide tube are carried in bearings in detached standards 22, one of which, with the parts carried by it, is shown separately in Fig. 5. Each strand passes through an outer guide-eye, 23, in an arm fixed to the standard 22, and then through a slit in a pin, 24, fixed in or formed on the end of the rocking shaft 21, and so placed that the strand enters the slit at a point coincident with the axis of the rocking shaft, as shown in Fig. 5. After passing through the slit in the pin 24 each strand passes into its tube 11. The groove in the cam-surface 18 forms two convolutions round the cam, crossing itself at one point, as shown in Fig. 4, to suit the opposite movements of the tubes or guide-arms 11 at alternate revolutions. Each crank-arm 17 is fitted with a cod-piece, 25, to work in the groove of the cam 18, this cod-piece being formed with a pin, which is held in an eye in the crank-arm 17, and which allows it to turn in passing from the upper part of the groove to the lower part, and vice versa, while its length insures it going correctly at the part where the groove crosses itself.

The shuttle or receiver plate 14 is driven by means of three pinions, 26, (see dotted lines, Fig. 3,) formed on the upper ends of tubular spindles 27, Figs. 2 and 4, mounted on studs 28, and having formed on their lower ends pinions 29, which are in gear with an internally-toothed ring, 30, formed in the same piece with the cam 18, hereinbefore referred to. The piece 30 18 is mounted upon a central vertical stud, 31, which is fixed in the bed-plate 32 of the machine, and it is driven by means of a pair of bevel wheels, 33, from a horizontal shaft, 34, provided with a driving-pulley, 35. The studs 28 of the pinions 26 29

are fixed in a flange formed on the upper end of the central stud, 31, and on their upper ends there is fixed by screws a circular plate, 36, which carries and guides the shuttle-plate 14, and to which there is fixed, by a central screw, a central plate, 37, made with a flange overlapping a flange formed at the central edge of the receiver or shuttle plate 14, so that this plate is prevented from rising out of its place.

In the plan view, Fig. 3, are shown some of the parts just referred to, but with the receiver or shuttle plate 14 supposed to be removed. The plates 36 and 37 are formed with three notches, 63, into which the strands descend, each when the receiver or shuttle plate 14 has to pass over it; and in Fig. 4 the section is taken as though passing through a notch on one side. The plate 14 is of course cut away to leave an opening for the free passage of the successive strands, as indicated in Fig. 1.

The take-up bobbin 13, which is carried on a horizontal stud, 38, fixed to the receiver or shuttle plate 14, is turned by means of a pinion, 39, fixed to its inner disk and driven by a spur-wheel, 40, on a spindle, 41, this spur-wheel 40 being driven frictionally by means of a rubber ring, 42, which can be more or less pressed against it by a nut, 64, screwed on the end of the spindle 41. The spindle 41 is driven by means of a worm-wheel, 43, fixed on it and having in gear with it a worm, 44, on a vertical spindle, 45, and this vertical spindle 45 is driven by means of a spur-wheel, 46, gearing with teeth formed round the circular plate 36, on which the receiver or shuttle plate 14 rests and turns. The spindles 41 and 45 are carried by the receiver or shuttle plate 14, and the revolution of this plate causes the spur-wheel 46 to be turned in consequence of being rolled round the teeth of the circular plate 36, which is stationary. A traverse-motion guide-arm, 47, pivoted to the plate 14, is worked by means of a worm, 48, on the spindle 41 of the take-up gear, this worm gearing with a worm-wheel, 65, carried by a stud and having fixed to it a cam, 49, which acts on a lever, 67, on one end of a rocking spindle, 50, while a lever, 51, at the other end of this rocking spindle is connected by a link, 52, to the traverse-motion guide-arm 47. The plaited material passes, as it is plaited, through the central guide-eye, 12, thence round the lower one of two guide-pulleys, 53, on the plate 14, to a pulley, 54, on the end of the horizontal spindle 41. The pulley 54 consists of a disk-shaped part and a beveled ring, the latter being fixed by a nut, 66, screwed on the end of the spindle, and being easily changed for rings of different sizes to suit the rate of take-up considered best in each case. From the changeable pulley 54 the plaited material returns to one of the guide-pulleys 53, and thence proceeds by guide-pulleys 55 and 56 to a guide-pulley, 57, at the end of the traverse-motion arm 47, which last leads it onto the take-up bobbin 13.

Guide eyes or pulleys may be provided for leading a strand or combination of strands

down to or up to the plaiting-center or central guide-eyes, 12, or strands may be led both down to and up to that center in the direction indicated by the dotted line 58 59 in Fig. 2, to serve as a core or cores for the plate to be formed on when additional substance is required. For the strand or strands passing up to the central guide-eye holes may be drilled through the central stud, 31, and through the screw which holds down the top central plate, 37.

There may be three or more tubes or guide-arms, 11, in the circle, or there may be three or more pairs of such tubes or guide-arms in the circle, the two of each pair being arranged as shown in Fig. 6 and turning about the same axis, but having the crank-arm 20, to which the actuating-links 15 are connected, placed oppositely, so that when one tube or arm 11 moves up the other moves down, and vice versa.

Figs. 7 and 8 are elevations at right angles to each other, showing a modification of the parts for actuating the tubes or guide arms 11. The crank-arm 17, which is acted on by the cam 18, is formed on the inner end of a tubular boss, 60, carried on a stud fixed to the standard 22, and this tubular boss 60 has formed or fixed on its other end a toothed sector, 61, which gears with a toothed sector, 62, (taking the place of the crank-arm 20,) and fixed or formed on the rocking shaft 21, which carries the tube or guide-arm 11.

Instead of the strands being led through tubes 11, they may be led through guide-eyes fixed to the arms, and these arms need not extend so far inward toward the center as in the machinery described in the earlier patent hereinbefore referred to.

Instead of winding the plait upon a bobbin on the receiving-plate, as shown and described, a cop-spindle may be substituted for the bobbin, with devices for turning the spindle to wind up the plaited material as it is formed.

The improved machinery is suitable for plaiting fibrous or other flexible materials—such as strands, threads, yarns, slivers, or bands of hemp, jute, cotton, straw, or other vegetable substances, or silks, woolen, or other similar substances, of asbestos or slag-wool or similar substances; also metallic bands, wires, or any combinations of these substances.

The yarns, threads, or other materials may be drawn into the plaiting machinery in any convenient way from cops, bobbins, spools, reels, or the like, or off balls or hanks, or out of cans or other receptacles.

I claim as my invention—

1. The mode herein described of plaiting together three or more strands or ends of fibrous or other flexible materials, said mode consisting in passing the combined or plaited

material in an annular path in rotation over and under the several strands or ends while the latter are moved across the path of the plaited material, substantially as set forth.

2. The combination of the plait-receiver or shuttle and mechanism, substantially as set forth, to traverse it in an annular path, with movable guides for the strands or ends, and devices, substantially as specified, for moving them across the path of the plait-receiver or shuttle, all substantially as described.

3. The combination of a traversing plait-receiver or shuttle and driving mechanism therefor with a grooved cam, vibrating guides for the ends or strands, and devices, substantially as described, whereby the cam controls the movement of the said tubes, all substantially as specified.

4. The combination of a traversing plait-receiver or shuttle and driving mechanism therefor with a central grooved cam, rocking shafts acted on by said cam, vibrating guides for the ends or strands, and devices, substantially as described, connecting the rocking shafts with said vibrating guides, all substantially as set forth.

5. The combination of the vibrating guides and devices, substantially as set forth, for operating them, with the plait-receiver or shuttle-plate and internally-toothed rings and pinions to rotate the said plate, all substantially as specified.

6. The plait-receiver or shuttle-plate having a bobbin and devices, substantially as described, to wind up the plaited material thereon, in combination with mechanism, substantially as set forth, for rotating the plate, guides for the ends or strands, and mechanism, substantially as described, for vibrating the said guides, all substantially as specified.

7. The combination of the rotating plait-receiver or shuttle-plate and devices, substantially as described, for operating the same, with a bobbin mounted on said plate and worm, worm-wheel, and connecting-gearing, substantially as set forth, to rotate the bobbin on the plate, all substantially as specified.

8. The combination of the traversing plait-receiver and driving mechanism therefor, with pairs of guides for the strands or ends, and devices, substantially as specified, for vibrating the two guides of each pair about the same axis, but in opposite directions, all substantially as set forth.

In testimony whereof I have signed my name to this specification in the presence of two subscribing witnesses.

NORMAN FRASER.

Witnesses:

EDMUND HUNT,
DAVID FERGUSON.