

June 7, 1955

G. OULIANOFF ET AL
FLAME TUBE STRUCTURE FOR COMBUSTION
EQUIPMENT OF GAS-TURBINE ENGINES

2,709,894

Filed Jan. 23, 1953

4 Sheets-Sheet 1

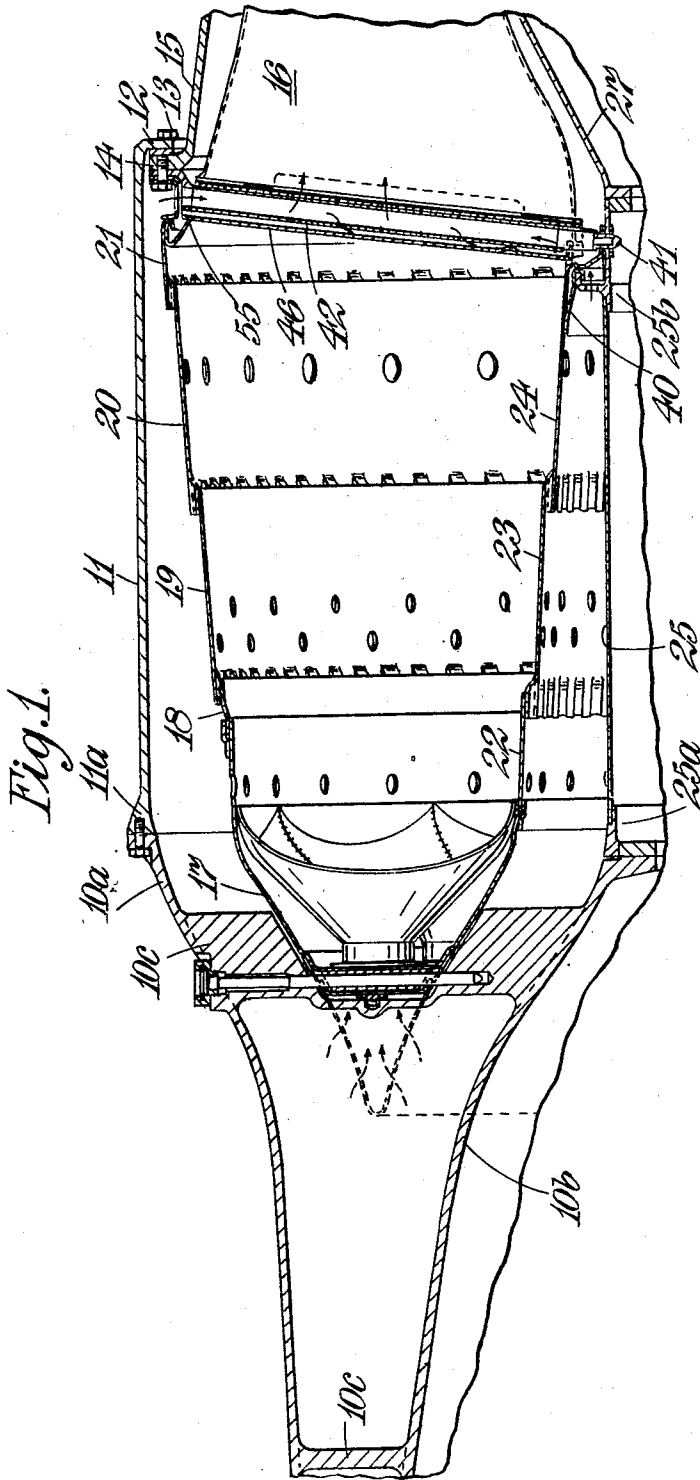

June 7, 1955

G. OULIANOFF ET AL
FLAME TUBE STRUCTURE FOR COMBUSTION
EQUIPMENT OF GAS-TURBINE ENGINES

2,709,894

Filed Jan. 23, 1953

4 Sheets-Sheet 2

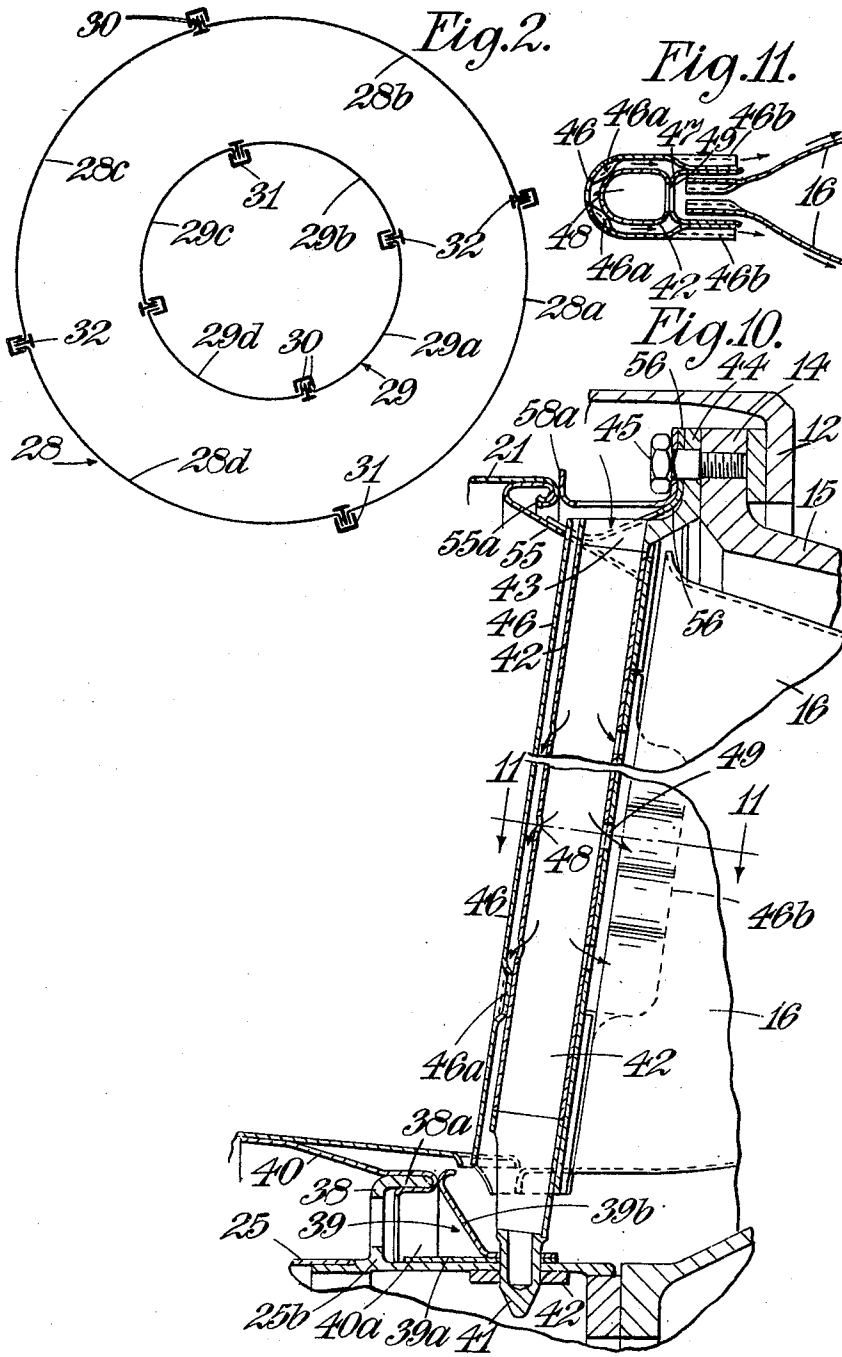

June 7, 1955

G. OULIANOFF ET AL
FLAME TUBE STRUCTURE FOR COMBUSTION
EQUIPMENT OF GAS-TURBINE ENGINES

2,709,894

Filed Jan. 23, 1953

4 Sheets-Sheet 3

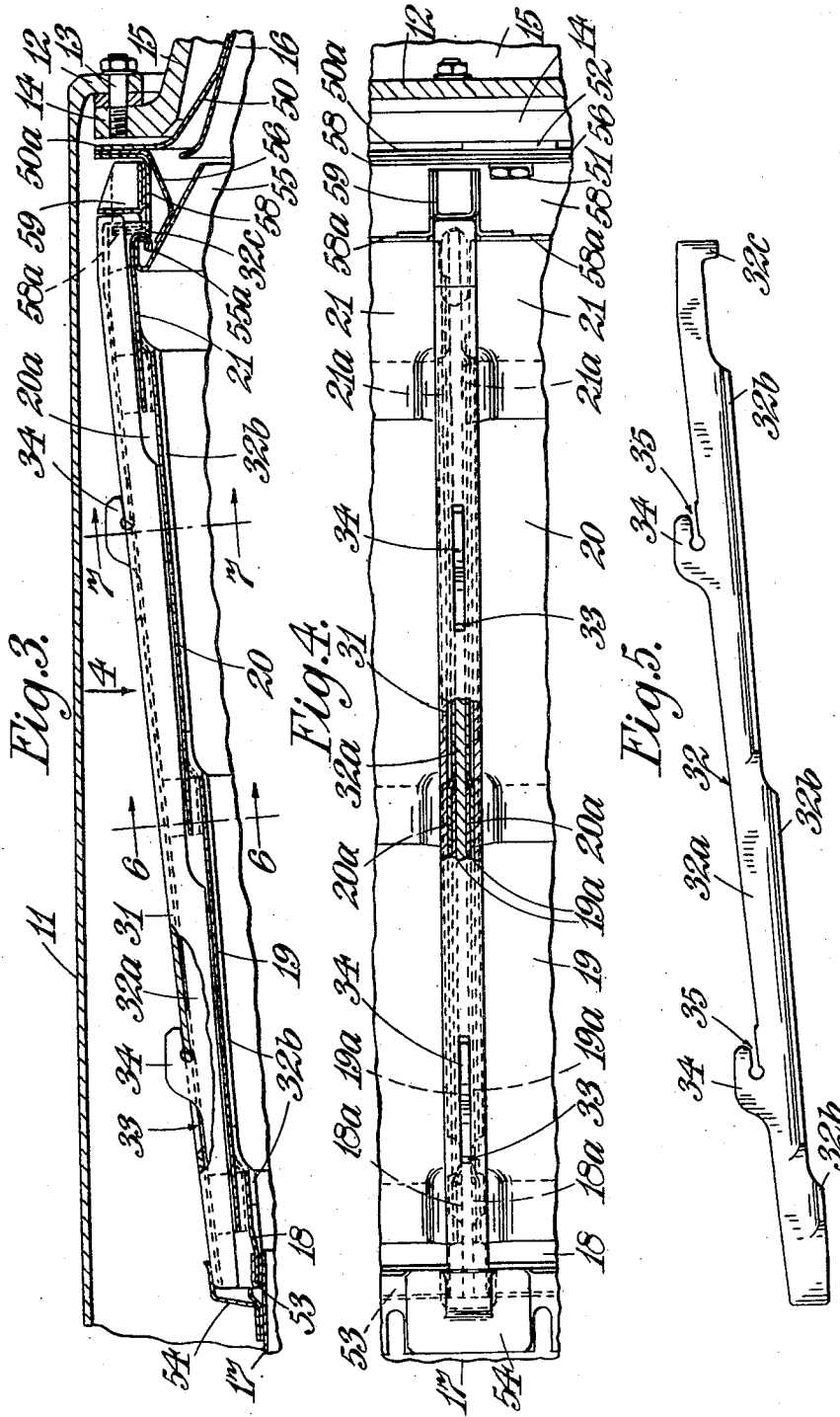

June 7, 1955

G. OULIANOFF ET AL
FLAME TUBE STRUCTURE FOR COMBUSTION
EQUIPMENT OF GAS-TURBINE ENGINES

2,709,894

Filed Jan. 23, 1953

4 Sheets-Sheet 4

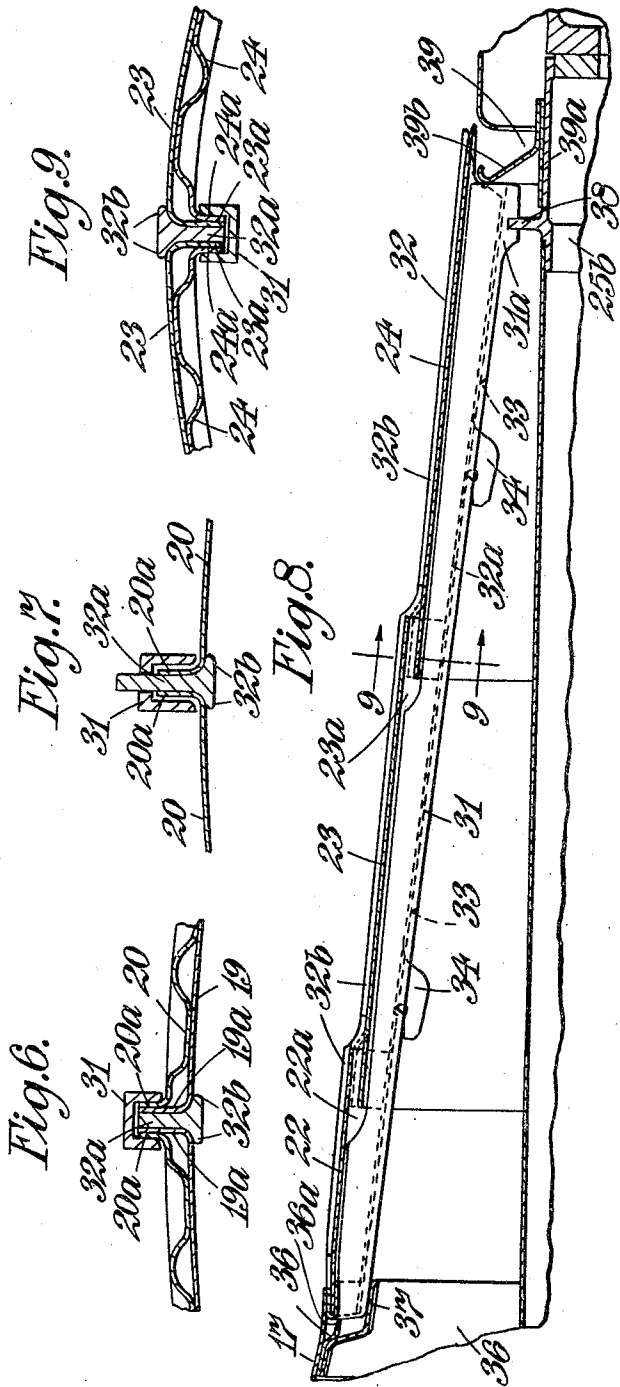

1

2,709,894

FLAME TUBE STRUCTURE FOR COMBUSTION EQUIPMENT OF GAS-TURBINE ENGINES

George Oulianoff, Allestree, and Jeffrey Evans, Alvaston, England, assignors to Rolls-Royce Limited, Derby, England, a British company

Application January 23, 1953, Serial No. 332,811

Claims priority, application Great Britain February 1, 1952

17 Claims. (Cl. 60—39.65)

This invention relates to combustion equipment of gas-turbine engines of the kind (hereinafter referred to as the kind specified), which comprises an annular air casing afforded by inner and outer coaxial casing walls, and within the annular space between these walls an annular flame tube having inner and outer walls which are coaxial with the walls of the air casing and in spaced relation thereto.

It is usual for the walls of an annular flame tube each to be made in a single section or a number of sections arranged end-to-end, each section being a complete annulus so that when dismantling the combustion equipment or replacing a flame tube, it is necessary first to dismantle another part of the engine such as the turbine.

This invention has for an object to provide an improved construction of flame tube whereby the flame tube walls can be removed from the engine without dismantling adjacent parts of the engine structure.

According to this invention, a flame tube for use in combustion equipment of the kind specified comprises a wall section formed of a plurality of segmental parts which together form a complete annulus, with flanges extending from corresponding surfaces of the segmental parts along their adjacent edges, and means to lock the segmental parts together comprising for each pair of adjacent flanges a channel member to extend along and straddle the flanges, a retainer member to extend along the adjacent edges of the pair of segmental parts in contact with the surfaces thereof which face oppositely to those from which the flanges project and interlocking features on said channel member and said retainer member to hold said members against radial disengagement and thereby to retain the flanges in engagement within the channel member.

According to a preferred feature of this invention, the interlocking features may comprise axially-slotted lugs projecting from the retainer member towards and through axial slots in the base of the channel member, the slots in the lugs having open ends to permit the slots to be engaged by relative axial movement of the members with the base of the channel member after the lug has been entered into a slot in the base of the channel member. The retainer member is preferably of T-section along part at least of its length.

According to another feature of this invention, in a construction of flame tube having each wall formed in a plurality of sections connected together end-to-end, each section is formed in a plurality of segmental parts as above set forth, the flanges on the segmental parts of adjacent sections are aligned, and each channel member and its associated retainer member are arranged to co-operate with an adjacent pair of sets of aligned flanges of a plurality of sections.

In some flame tubes of this construction, the upstream end of one section is arranged slightly to overlap the downstream end of an adjacent section and the two overlapping ends are interconnected in such a manner as to afford between them air inlets to the interior of the flame

2

tube. The flame tube thus has a stepped form. In such an arrangement the channel member may have its side flanges stepped to accommodate the stepped form of the flame tube and the retainer member may comprise a continuous web which lies between the flanges of the segmental parts of the flame-tube sections and a series of axially-spaced, lateral webs in a stepped disposition to bear against the surfaces of the segmental parts of the flame-tube sections, and in a construction in which the interlocking features comprise slotted lugs the lugs may be formed along one edge of the continuous web.

According to another feature of this invention, means is provided in the combustion equipment to prevent disengagement of the interlocking features on the channel members and retaining members. For instance, in a construction having the interlocking features formed by axially-slotted lugs on the one member and axial slots in the other member, the means to prevent disengagement of the channel and retaining members may comprise an abutment on the flame-tube structure to be engaged by a nose on one of the members or a flange to be engaged by a notch in one of the members thereby to hold said member against axial displacement in one direction at least and a retaining ring or annular structure to engage the other of the members to hold it against axial displacement. The annular structure may be formed in a number of segments. The retaining ring for the channel and retainer members associated with an inner wall of a flame tube will be relatively inaccessible and according to a feature of this invention the retaining ring may be locked in position by a peg carried at the end of a tubular member which extends across the flame tube from adjacent the outer wall and the tubular member may be held in position by being bolted for instance to the outer structure of the combustion equipment. Thus, to release the retaining ring for the inner wall of the flame tube the tubular member is unbolted from the outer structure of the combustion equipment and then withdrawn. The tubular member may be located adjacent the outlet end of the flame tube and employed to convey cooling air to between nozzle discharge chutes which lead from the flame tube to a turbine of the gas-turbine engine.

One embodiment of this invention will now be described by way of example reference being made in the description to the accompanying drawings, in which:

Figure 1 is an axial section through part of combustion equipment of the kind specified,

Figure 2 is a diagram illustrating the invention,

Figure 3 is a view illustrating an application of the invention to the form of combustion equipment illustrated in Figure 1,

Figure 4 is a view in the direction of arrow 4 of Figure 3,

Figure 5 is a view corresponding to Figure 3 of one element of the combustion equipment,

Figures 6 and 7 are local sections on the lines 6—6 and 7—7 respectively of Figure 3,

Figure 8 is a view corresponding to Figure 3 showing another application of the invention in combustion equipment as illustrated in Figure 1,

Figure 9 is a section on the line 9—9 of Figure 8,

Figure 10 is part of Figure 1 drawn to a larger scale, and

Figure 11 is a section on the line 11—11 of Figure 10.

Referring to Figure 1, the combustion equipment illustrated is of the kind specified and comprises an air casing having an expansion-chamber section and a main flame-tube-enclosing section, and a flame tube arranged within the annular space afforded by the air casing.

The expansion-chamber section of the air casing has an outer wall 10a, an inner wall 10b and a series of hollow struts 10c interconnecting the outer and inner walls

10a and 10b, these parts conveniently being formed in one piece.

The main flame-tube-enclosing section of the air casing comprises an outer wall 11 of cylindrical form, the upstream edge 11a of which is thickened to receive setscrews by which the wall is secured in abutment with the downstream edge of the outer wall 10a of the expansion-chamber section; the downstream edge of the wall 11 is formed with an inward flange 12 which is secured by setscrews 13 in abutment with the downstream side of a flange 14 formed on an outer casing member 15 enclosing a series of nozzle discharge chutes 16 through which combustion gases from the combustion chamber are fed to the turbine of the engine.

The main flame-tube-enclosing section of the air casing also comprises an inner wall 25 which is coaxial with the outer wall 11 and has at its upstream end a strengthening ring 25a having a sliding engagement with the downstream edge of the inner wall 10b of the expansion-chamber section. The downstream edge of the wall 25 has secured to it a ring 25b which has sliding engagement with an adjacent inner wall 27 which forms part of the nozzle-box structure for enclosing the nozzle discharge chutes 16.

The flame tube comprises an inlet section 17 which is generally of wedge form with the apex of the wedge located upstream, and the inlet section 17 is conveniently supported on the struts 10c, for example in the manner set forth in the specification of our concurrent application U. S. Serial No. 332,812, filed 23rd January, 1953. The walls of the inlet section 17 diverge in the radial sense to form the leading portions of inner and outer walls of the flame tube.

The outer wall of the flame tube comprises, in addition to the part of it afforded by the inlet section 17 which may be fully annular, a number of units formed by segmental parts of four wall sections 18, 19, 20 and 21. The wall sections 18, 19, 20, 21 are secured together as by welding in end-to-end relation with overlap between the downstream edge of one section and the upstream edge of the adjacent section, and the overlapping parts of the sections 18, 19, 20, 21 are arranged to afford axially-extending air passages by means of which air can pass from the space between the wall 11 and the sections 18-21 to within the flame tube. In the construction shown there are four such units, and thus the segmental parts each extend over a quarter of the circumference of a circle; however the outer wall of the flame tube may be formed of any convenient number of units. The units formed by segmental parts of sections 18 to 21 are conveniently put in position after the inlet section 17 has been located.

The inner wall of the flame tube comprises, in addition to the part thereof afforded by the inlet section 17, a number of units formed by segmental parts of three wall sections 22, 23, 24, secured together as by welding in end-to-end relation with their edges in overlapping relation. The wall sections 22, 23, 24, are arranged to form air passages in the same way as do the outer wall sections, the passages leading from the space between the inner flame tube wall sections 22, 23, 24 and the inner wall 25 of the air casing to within the flame tube. Again, the inner wall of the flame tube may be formed of any convenient number of segmental units.

When combustion equipment of the kind specified forms part of a gas-turbine engine, it is usual for a driving shaft to extend through the centre of the combustion equipment and therefore if the flame-tube wall sections 18 to 24 are formed as complete annuli it is necessary to dismantle large portions of the engine before the flame tube can be replaced.

The present invention provides an arrangement whereby the flame-tube wall sections 18 to 24 can be removed from the engine without dismantling large sections of the engine.

The arrangement of the invention is illustrated diagrammatically in Figure 2 in which reference numeral 28 indicates the outer wall structure of the flame tube and the reference numeral 29 the inner wall structure of the flame tube. It will be seen that each of the walls 28 and 29 is made in four arcuate or segmental parts 28a, 28b, 28c, 28d, and 29a, 29b, 29c and 29d respectively and these segmental parts are connected together at their adjacent axially-extending edges.

The axially-extending edges of the segmental parts are formed with flanges 30, which in the case of the outer wall extend outwardly and in the case of the inner wall extend inwardly, and the flanges 30 are held against circumferential and radial separation by locking means comprising a channel member 31 which extends along and straddles the adjacent pair of flanges 30 and a T-section retaining member 32, the lateral webs of which abut against the surfaces of the segmental parts opposite those from which the flanges 30 project and the central web of which projects between the flanges 30 and has interlocking engagement with the base of the associated channel member 31. It will be seen that with the parts 31 and 32 interlocked the flanges 30 on adjacent axially-extending edges of the segmental parts of the flame tube walls cannot separate in the circumferential direction, being held against such a separation by the side flanges of the channel member 31, and cannot separate in the radial direction being held between the lateral flanges of the associated T-section retainer member 32 and the base of the channel member 31.

Turning now to Figures 3 to 7, there is illustrated the manner in which this arrangement for facilitating assembly of a flame tube is applied to the outer wall of the flame tube. In this application the sections are provided along their axially-extending adjacent circumferential edges with flanges 18a, 19a, 20a, 21a respectively and, as will be seen best from Figure 6, where the sections overlap the flanges are in contact with one another. The channel member 31 has its side flanges spaced apart by an amount equal to the thickness of the four flanges 19a and 20a plus the thickness of the central web 32a of the T-section member 32, and therefore intermediate the overlapping portions of the sections 18-21 the side flanges of the channel member 31 are clear of the adjacent flanges 18a, 19a, 20a, or 21a (Figure 7).

As will best be seen from Figure 3, the side flanges of the channel member 31 are stepped to accommodate the sudden increase in the diameter of the flame tube at the overlapping portions and similarly the T-section member 32 is shaped to accommodate sudden changes in diameter. As will best be seen from Figure 5, the T-section member has a continuous central web 32a, the under-edge of which as viewed in Figure 5 is stepped to accommodate the changing diameter of the flame tube, and also has on each side of the web 32a a series of axially-spaced lateral webs 32b which are disposed step-wise. Each lateral web 32b extends from the downstream edge of the associated flame-tube section part-way only along the adjacent edges of the segmental parts of the section.

The channel member 31 and the T-section member 32 are interlocked by forming slots 33 in the base of the channel member 31 and by providing correspondingly-positioned lugs 34 to project from the free edge of the central web 32a of the T-section retainer member. The lugs 34 are slotted axially (as indicated at 35) to afford a hook formation and the two parts are interlocked by passing the lugs 34 through the slots 33 and then displacing the two parts axially with respect to one another to engage the slot formations 35 with the base of the channel member 31 beyond one end of the slot 33.

Referring now to Figures 8 and 9 it will be seen that a similar arrangement of channel member 31 and T-section retainer member 32 is employed to hold the segmental parts of the sections 22, 23 and 24 of the inner wall of the flame tube against circumferential and radial

5

6

separation. In this case flanges 22a, 23a and 24a are provided to project inwardly from the segmental parts, the channel member 31 is located within the space between the sections 22, 23, 24 and the inner wall 25 of the air casing, with its side flanges projecting outwards to straddle the flanges 22a, 23a, 24a, and the T-section member has its central web 32a extending radially inwards. The slot formations afforded by lugs 34 are engaged with the base of the channel member 31, to maintain the parts in assembly, by relative axial displacement of the T-section retainer member 32 and the channel member 31, as described with reference to the construction shown in Figures 3-7.

In the arrangements illustrated, there is also provided means to prevent axial relative movement of the channel members 31 and retainer members 32 in operation of the engine due, for instance, to vibration.

Referring to Figure 8, it will be seen that the leading edge of the section 22 of the wall is engaged with an annular socket provided on the inlet section 17 of the flame tube, which annular socket is formed by securing to the radially inner surface of the wall of the inlet section 17 a sheet-metal ring 36 having a joggled section so that the downstream portion of the joggled-section ring is spaced radially inwards from the downstream edge of the main wall of the inlet section 17. The joggled-section ring 36 is provided with axial slots 36a in line with the location of the flanges 22a on the section 22 of the flame tube wall and when the units formed by the sections 22, 23, 24 are placed in position the flanges 22a enter the slots 36a, projecting radially inwards therethrough. Metal patches 37 are welded to the joggled-section ring 36 to enclose the slots and to provide pockets to receive the upstream ends of the flanges 22a, the upstream ends of the continuous webs 32a of the retainer member 32, and the upstream ends of the channel-section members 31 thereby to support these parts and to prevent their axial displacement in the upstream direction when the units are properly in position.

The channel member 31 is located against axial displacement in the downstream direction by forming on it at its downstream end an extended portion 31a which is notched to engage over a radially-extending, circumferential flange 38 provided on the ring 25b forming part of the inner air casing wall 25.

The flange 38 has a rearwardly-extending portion 38a (see Figure 10), interrupted at the circumferential position of flanges 24a, to provide a support for the rear end of the segmental wall units through flanges 40 welded to the inner surface of the segmental portions of the section 24, the downstream edge of the flange 40 being turned back on itself as indicated at 40a, to engage over the portion 38a of the flange 38.

The flame tube units formed by the sections 22, 23, 24 and the retainer members 32 associated with the units are retained against axial displacement by a fully annular retaining ring 39 axially slidable on the ring 25b. The retaining ring 39 comprises a cylindrical portion 39a having a slight clearance from the ring 25b and a flanged portion 39b with a rolled-over edge to provide an abutment for the downstream ends of the retainer members 32 (Figure 8) and to hold the turned back edges 40a of the flanges 40 in engagement with the rearwardly-extending portions 38a of the flange 38 (see Figure 10).

The retaining ring 39 is locked in its operative position by means of a series of pegs 41 which pass through holes in the downstream portions of the parts 39a, 39b of the retaining ring 39 to engage in holes in the ring 25b. The ring 25b may be strengthened in the region of the holes by having washer-like members 42 welded thereto.

The pegs 41 are carried at the ends of a corresponding series of tubular members 42 which extend substantially radially outward across the working fluid passage through the combustion equipment in line with the spaces between

the adjacent radial walls of neighbouring nozzle discharge chutes 16.

The tubular members 42 (see Figures 10 and 11) are open at their upper ends and have secured to them rings 43 provided with upstanding lugs 44 by which the tubes 42 are supported from the flange 14 on the outer casing member 15 of the nozzle box structure; setscrews 45 are provided to extend through the lugs 44 and engage in threaded bores in the flange 14.

Each of the tubular members 42 is provided with a shield to protect it from excessive heating. The shield comprises a U-section wall member 46, which is held in spaced relation with respect to the tubular member 42 by dimples 46a and which has the limbs of the U-section one on each side of the tubular member and extending rearwardly beyond the tubular member, and also a channel-section wall member 47, the base of which is welded to the rear surface of the tubular member 42 and the side flanges of which are in contact with and welded to corrugations 46b in the downstream edge portions of the limbs of the U-section wall member. The space between the side flanges of the channel-section wall member 47 affords a radially-extending socket to receive the upstream edges of the radial walls of the nozzle discharge chutes 16.

Air enters each of the tubular members 42 through its outer end and flows partly through holes 48 in the front wall thereof into the part-annular space between the tubular member 42 and the wall member 46, passing between the corrugations 46b of wall member 46 and the side flanges of channel member 47 to cool the inner surfaces of the radial walls of neighbouring nozzle discharge chutes 16, and partly through holes 49 in the rear walls of the tubular members 42 and in the bases of the channel-section wall members 47 into the spaces between the nozzle discharge chutes 16 to cool the outer surfaces of the radial walls which face towards one another.

To release the retaining ring 39 to permit it to slide rearwardly on the ring 25b, the setscrews 45 are removed and the tubular members 42 together with their heat shields 46 are withdrawn from the combustion equipment. Removal of these parts can only be effected after removal of the outer walls of the flame tube.

The nozzle discharge chutes 16 are supported at their inlet ends from the flange 14 by each chute being provided with a segmental flange 50 (Figure 3) which is welded to the radially outer surface of the discharge chute 16 and has a portion 50a lying adjacent the front face of but in spaced relation to the flange 14. Setscrews 51 (Figure 4) similar to the setscrews 45 but circumferentially spaced therefrom, extend through the outer portions 50a of the segmental flange 50 and spacer pieces 52 to engage threaded bores in the flange 14.

In certain cases the discharge chutes 16 may be fully annular, having separate outer and inner annular walls, in which case tubular member 42 may have a fully annular shield 46, or alternatively the ring 39 may be located against axial movement in any desired or convenient manner.

The units formed by the segmental parts of the sections 18, 19, 20 and 21 of the outer flame tube wall are supported and locked in position in the following manner.

The upstream edge of the segmental parts of the section 18 engage in an annular socket afforded by a U-sectioned, sheet-metal ring 53 (Figure 3) which is welded to the outer surface of the outer wall of the inlet section 17 of the flame tube. The ring 53 is slotted at the location of flanges 18a, and pockets are provided to receive the upstream ends of the retainer members 32 and channel members 31, the pockets being formed by patches 54 welded to the external surface of the outer wall of the inlet section 17 in alignment with the junction between the segmental parts of the section 18. During assembly the downstream ends of the segmental parts are supported by being engaged with a rolled edge 55a formed on a sheet-metal member 55 which affords an outlet nozzle

leading from the flame tube into the nozzle discharge chutes 16. The outlet nozzle member 55 is supported from the flange 14 by having secured thereto a flange of a sheet-metal full circular annulus 56 which has a second flange bolted to the flange 14 by means of the studs 45 and 51. The outlet nozzle member 55 and the sheet-metal annulus 56 are cut away adjacent the tubular members 42.

It will be seen from Figures 3 and 10 that the downstream edge of the segmental parts of the section 21 are rolled over to be capable of having a hook-like engagement with the rolled edge 55a. When the wall sections are properly positioned the two rolled edges completely engage with one another.

The retainer members 32 in this case are held against undesired movement in the upstream direction by being provided at their downstream ends each with a nose 32c which co-operates with the turned-over edges of the segmental wall parts of the section 21 and the rolled edge 55a.

The retainer members 32 and the channel members 31 and the units formed by the segmental parts of the sections 18, 19, 20 and 21 are held against undesired movement in the downstream direction by a retaining ring which is made in segments 58 which are notched to receive the ends of the channel members 31 and retainer members 32 and have sheet-metal pieces welded thereto around the notches, as indicated at 59 in Figures 3 and 4, to locate the ends of the members both circumferentially and axially. The segments 58 of the retaining ring are secured to the flange 14 by means of the setscrews 45 and 51 above referred to; the segments 58 are also provided with radial flanges 58a at their upstream edges and these flanges, as will best be seen from Figure 10, hold the rolled-over edges of the segmental parts of the section 21 in engagement with the rolled-over edge 55a. The segments 58 are apertured adjacent the tubular members 42.

In dismantling the combustion equipment above described the following sequence of operations can be employed.

First the setscrews 13 are removed and the outer air casing wall 11 is withdrawn bodily in a downstream direction, that is to the right as viewed in Figure 3, thus exposing the flame tube. Next the setscrews 45 and 51 are removed from each of the segments 58 of the retaining ring for the outer wall of the flame tube in turn, and this segment is removed from the combustion equipment and the setscrews are temporarily replaced in order to secure the annular member 56 in place during removal of the flame tube segments. The channel members 31 of the outer flame-tube wall are next removed by axial movement in the downstream direction thus disengaging them from the lugs 34 of the retainer members 32, and the units formed by the segmental parts of the sections 18, 19, 20 and 21 can now be removed in turn. After removal of these units, the tubular members 42 and their shields 46 are removed thus releasing the retaining ring 39 of the inner flame-tube wall. This part can now be slid rearwardly freeing each of the retainer members 32 of the inner flame-tube wall for rearward movement thus permitting its disengagement from the associated channel member 31. After removal of the retainer members 32 the units forming the inner flame-tube wall can be removed.

In assembly of the combustion equipment, the reverse process is employed, and when securing the last of the segmental parts of the outer flame tube sections in position, the retainer members 32 are supported at their upstream ends by the inlet section 17 and at their downstream ends by the annular member 56 thus allowing the channel members 31 readily to be engaged within the slots 35.

It will be understood that the invention is not limited to the construction above described but is directed to an arrangement of combustion equipment of the kind specified in which a flame tube wall is formed in segmental

parts clamped together in a readily-detachable manner over their adjacent axially-extending edges.

We claim:

1. An annular combustion chamber of the kind employed in an aircraft gas turbine engine comprising an air casing having an inlet end and an outlet end and including an inner annular wall and an outer annular wall, and a flame tube comprising a plurality of arcuate parts, each having a pair of edges extending axially of the combustion chamber, said arcuate parts being adapted on circumferential assembly about the combustion chamber axis with their axially-extending edges juxtaposed in pairs together to form a fully annular wall section, and said arcuate parts having flanges along their axially-extending edges, the pairs of flanges at the adjacent edges of neighbouring parts being correspondingly-directed, a channel member for each pair of flanges to extend along and straddle said flanges, and a retainer member for each channel member to extend along the adjacent edges of the pair of neighbouring parts on the side of the parts remote from the flanges and in contact with said parts, said channel member and said retainer member having disengageable mutually interlocking parts to hold said members in engagement.

2. An annular combustion chamber of the kind employed in an aircraft gas turbine engine comprising an air casing having an inlet end and an outlet end, and including an inner annular wall and an outer annular wall, and a flame tube comprising a plurality of arcuate parts, each having a pair of edges extending axially of the combustion chamber, said arcuate parts being adapted on circumferential assembly about the combustion chamber axis with their axially-extending edges juxtaposed in pairs together to form a fully annular wall section, and said arcuate parts having flanges along their axially-extending edges, the pairs of flanges at the adjacent edges of neighbouring parts being correspondingly-directed, a channel member for each pair of flanges to extend along and straddle said flanges, said channel member having a base formed with axial slots, and a T-section retainer member for each channel member having a central web and a pair of lateral webs, whereof the lateral webs extend one along each of the adjacent edges of the pair of neighbouring arcuate parts on the side of the arcuate parts remote from the flanges and in contact with said arcuate parts, and whereof the central web extends between the flanges of said neighbouring arcuate parts and is formed at its free edge with a plurality of projecting axially-slotted lugs to pass through and engage with the axial slots in the base of said channel member.

3. In combustion equipment of the class comprising an annular air casing afforded by inner and outer coaxial casing walls, and within the annular space between these walls an annular flame tube having inner and outer walls which are coaxial with the walls of the air casing and in spaced relation thereto; a construction of flame tube wall which comprises a wall section comprising a plurality of arcuate parts, each having a pair of edges extending axially of the combustion equipment, said arcuate parts being adapted on circumferential assembly about the axis of the combustion equipment with their axially-extending edges in juxtaposed pairs together to form a complete annulus, the arcuate parts having flanges projecting in the same sense from them along their axially-extending edges, and means to lock the accurate parts together comprising for the flanges of each pair of adjacent axially extending edges a channel member to extend along and straddle the flanges, a retainer member to extend along the adjacent axially extending edges of the pair of arcuate parts in contact with the surfaces thereof which face in the opposite sense to that in which the flanges project, and interlocking parts on said channel member and said retainer member to hold said members against radial disengagement and thereby to retain the flanges in engagement within the channel member.

4. Combustion equipment as claimed in claim 3, wherein the interlocking parts comprise axially-slotted lugs projecting from the retainer member towards and through axial slots in the base of the channel member, the slots in the lugs having open ends to permit the slots to be engaged by relative axial movement of the members with the base of the channel member after the lug has been entered into a slot in the base of the channel member.

5. Combustion equipment as claimed in claim 3 comprising means to prevent disengagement of the interlocking parts on the channel members and retaining members.

6. Combustion equipment as claimed in claim 5, wherein the interlocking parts are disengageable by an axial movement, and wherein the means to prevent disengagement of the members comprises an abutment on the flame tube structure to be engaged by a nose at one end of one of the members and an annular retaining structure co-operating in abutment with corresponding end of the other member.

7. Combustion equipment as claimed in claim 6, wherein said annular retaining structure is formed by a circumferential assembly of segments detachably mounted in the combustion equipment.

8. Combustion equipment as claimed in claim 7, wherein the annular retaining structure also co-operates with the adjacent flame tube structure to locate the flame tube axially in one direction at least.

9. Combustion equipment as claimed in claim 8, wherein the arcuate parts of the flame tube wall section and channel member and retaining member are located in the opposite direction by being received in axially-facing annular sockets in adjacent located structure.

10. Combustion equipment as claimed in claim 3, having the channel and retainer members adapted to be disengaged by a relative axial movement, and having means to retain the members against axial movement which includes a notch on one of them engaged on a circumferentially-extending radial flange projecting from adjacent combustion equipment structure and comprises also a retaining ring to co-operate with the other of the members.

11. Combustion equipment as claimed in claim 10, wherein the retaining ring is axially displaceable to release the members for relative axial movement and releasable means is provided to lock the retaining ring in position.

12. Combustion equipment as claimed in claim 11, wherein the retaining ring is formed with apertures and the releasable locking means comprises a tubular member which extends across the flame tube from adjacent the outer wall to adjacent the inner wall, and a peg carried at the end of said tubular member to engage in said apertures and in adjacent fixed combustion equipment structure.

13. Combustion equipment as claimed in claim 12, wherein the tubular member is held in position by being bolted to outer structure of the combustion equipment.

14. Combustion equipment as claimed in claim 12, comprising also a plurality of circumferentially-spaced nozzle boxes leading from the outlet end of the flame tube and having the tubular member located adjacent the outlet end of the flame tube and adapted to convey cooling air to spaces between said nozzle boxes.

15. Combustion equipment as claimed in claim 14, wherein the tubular member is enclosed within a U-section heat shield the free edges of which extend downstream between the nozzle boxes and wherein the heat shield is in spaced relation to the tubular member to form an air passage therebetween.

16. Combustion equipment as claimed in claim 11, wherein the retaining ring also engages adjacent flame tube sections to locate them axially in one direction at least.

17. Combustion equipment as claimed in claim 16, wherein the flame tube sections, channel members and retainer members are located in the opposite direction by engagement in an annular axially-facing socket.

References Cited in the file of this patent

UNITED STATES PATENTS

2,448,561	Way	Sept. 7, 1948
2,547,619	Buckland	Apr. 3, 1951
2,617,255	Niehus	Nov. 11, 1952