

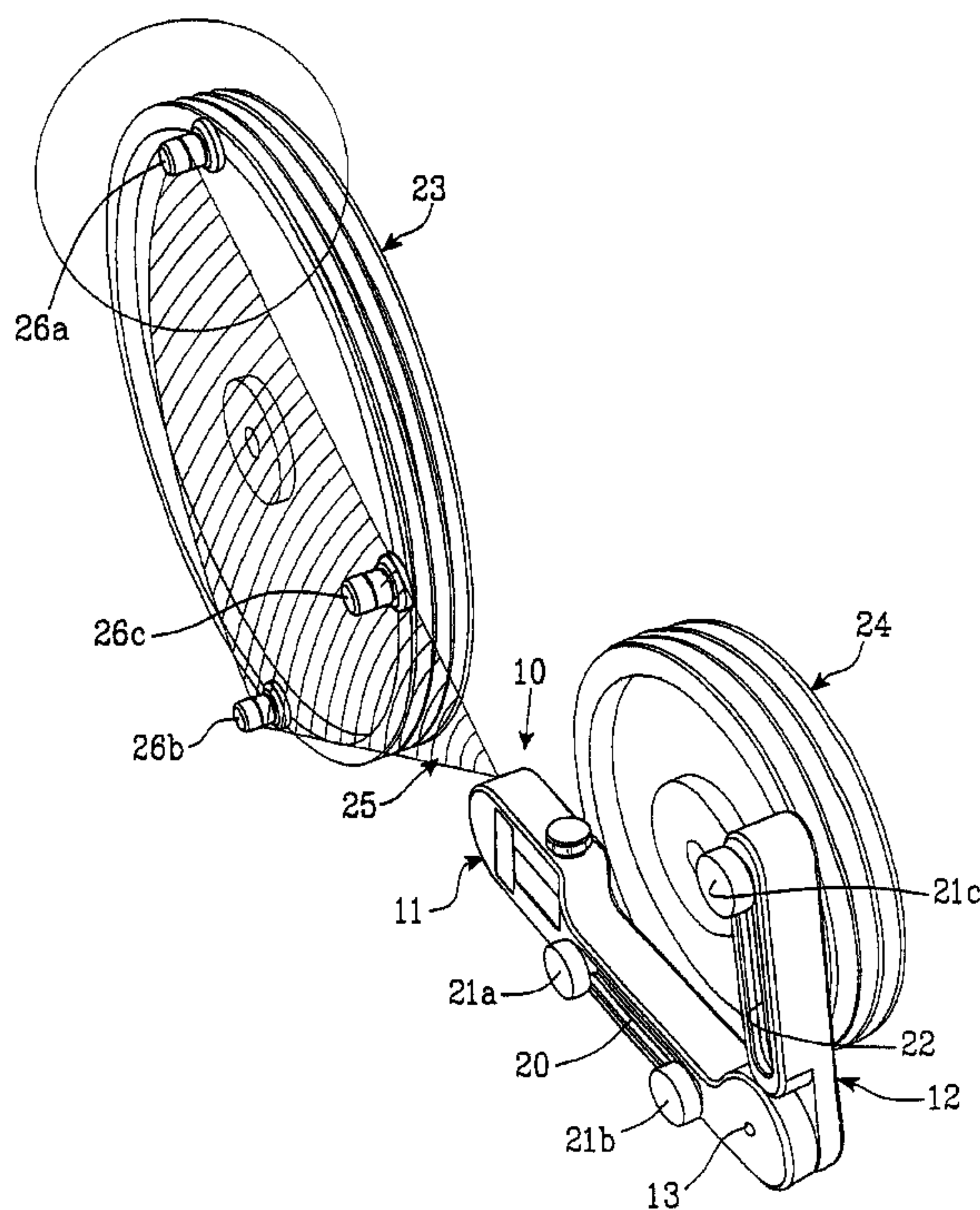

(86) Date de dépôt PCT/PCT Filing Date: 1999/11/09  
 (87) Date publication PCT/PCT Publication Date: 2000/05/18  
 (85) Entrée phase nationale/National Entry: 2001/05/09  
 (86) N° demande PCT/PCT Application No.: SE 99/02034  
 (87) N° publication PCT/PCT Publication No.: WO 00/28275  
 (30) Priorité/Priority: 1998/11/10 (9803851-6) SE

(51) Cl.Int.<sup>7</sup>/Int.Cl.<sup>7</sup> G01B 5/25, G01B 11/27  
 (71) Demandeur/Applicant:  
DAMALINI AB, SE  
 (72) Inventeur/Inventor:  
ANDERSSON, NILS, SE  
 (74) Agent: MARKS & CLERK

(54) Titre : DISPOSITIF ET PROCEDE D'ALIGNEMENT  
 (54) Title: DEVICE AND METHOD FOR ALIGNMENT



(57) **Abrégé/Abstract:**

The present invention refers to a system and a device (10) for alignment of at least one alignable plane with reference to at least one reference plane. The device includes a main part (11), a light source (18) and a number of contact points (21a, 21b, 21c), and the light source (18) is provided to emit a light beam (25) with a scattering angle in one plane.



PCT

WORLD INTELLECTUAL PROPERTY ORGANIZATION  
International Bureau

INTERNATIONAL APPLICATION PUBLISHED UNDER THE PATENT COOPERATION TREATY (PCT)

(51) International Patent Classification <sup>7</sup> : <b>G01B 5/25, 11/27</b>	<b>A1</b>	(11) International Publication Number: <b>WO 00/28275</b> (43) International Publication Date: 18 May 2000 (18.05.00)
<p>(21) International Application Number: PCT/SE99/02034</p> <p>(22) International Filing Date: 9 November 1999 (09.11.99)</p> <p>(30) Priority Data: 9803851-6      10 November 1998 (10.11.98)      SE</p> <p>(71) Applicant: DAMALINI AB [SE/SE]; Åbäcksgatan 6B, S-431 67 Mölndal (SE).</p> <p>(72) Inventor: ANDERSSON, Nils; Svensavägen 8401, S-434 98 Kungälv (SE).</p> <p>(74) Agent: GÖTEBORGS PATENTBYRÅ DAHLS AB; Sjöporten 4, S-417 64 Göteborg (SE).</p>	<p>(81) Designated States: AE, AL, AM, AT, AU, AZ, BA, BB, BG, BR, BY, CA, CH, CN, CR, CU, CZ, DE, DK, DM, EE, ES, FI, GB, GD, GE, GH, GM, HR, HU, ID, IL, IN, IS, JP, KE, KG, KP, KR, KZ, LC, LK, LR, LS, LT, LU, LV, MA, MD, MG, MK, MN, MW, MX, NO, NZ, PL, PT, RO, RU, SD, SE, SG, SI, SK, SL, TJ, TM, TR, TT, TZ, UA, UG, UZ, VN, YU, ZA, ZW, ARIPO patent (GH, GM, KE, LS, MW, SD, SL, SZ, TZ, UG, ZW), Eurasian patent (AM, AZ, BY, KG, KZ, MD, RU, TJ, TM), European patent (AT, BE, CH, CY, DE, DK, ES, FI, FR, GB, GR, IE, IT, LU, MC, NL, PT, SE), OAPI patent (BF, BJ, CF, CG, CI, CM, GA, GN, GW, ML, MR, NE, SN, TD, TG).</p> <p><b>Published</b> <i>With international search report. Before the expiration of the time limit for amending the claims and to be republished in the event of the receipt of amendments.</i></p>	

(54) Title: DEVICE AND METHOD FOR ALIGNMENT

## (57) Abstract

The present invention refers to a system and a device (10) for alignment of at least one alignable plane with reference to at least one reference plane. The device includes a main part (11), a light source (18) and a number of contact points (21a, 21b, 21c), and the light source (18) is provided to emit a light beam (25) with a scattering angle in one plane.

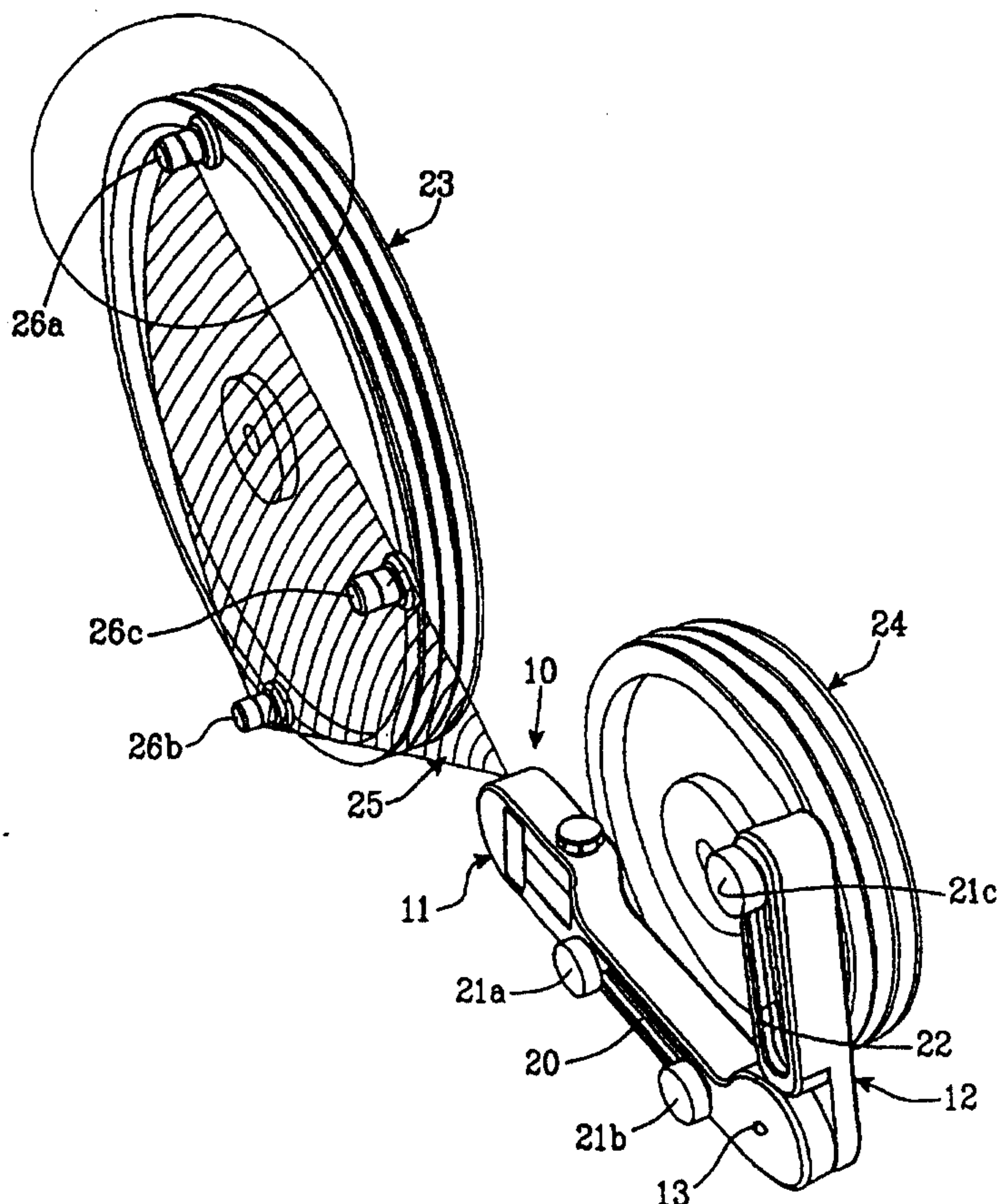

Title:

## DEVICE AND METHOD FOR ALIGNMENT

### 5 **Technical field of the invention**

The present invention relates to a device for alignment of at least one alignable plane with respect to at least one reference plane.

10 The invention also refers to a system and a method for alignment of at least one alignable plane with respect to at least one reference plane.

### **Background of the invention**

15 Usually, at power transmission between rotary shafts, for example via belt or sheave, it is required that the driving and the driven wheels are mutually, at least plane-parallel and adjusted axially in line with each other. This is mainly to prevent abnormal wear of the belts or chains arranged in the power transmission.

### 20 **Prior art**

Presently, string and straight edges are used when aligning sheave/gear wheels. The string and straight edge is manually provided on the axial plane of one of the wheels. The string and straight edge is then held in such a direction that its distance to the axial plane of the other  
25 wheel can be estimated. This gives however only an estimation of the mutual position and the point of the wheels in one direction, whereby the string and straight edge is turned to a new position on the other wheel and a new estimation of the distance between ruler and wheel can be obtained. This distance is compared to the first one in order to obtain an estimation of the mutual position and the direction of the wheel in the other direction. This method, which  
30 prevents a simultaneous alignment of the wheels by one operator and the fact that the string and straight edge must be of such a length that it fits the periphery of both wheels makes the alignment to become time consuming and inaccurate.

Moreover, alignment with a string and straight edge is normally done by two mechanics.

**The object of the invention and the most important characteristics**

- 5 The object of present invention is to provide a simple and cost-effective device which allows simple and quick adjustment and alignment of at least two essentially plane surfaces. The substantially visible light beam used for the alignment shows the parallel and angular misalignment directly.
- 10 A further object of the invention is to provide a device mainly intended for adjustments of sheaves/gear wheels in power transmission systems having rotary shafts, preferably through optical measurement, in industrial environment and a corresponding measurement method.

Through the teachings of the invention, the alignment results in reduced vibration, extended  
15 life of belt and sheaves, proper belts tensioning and also eliminated downtime and production delays.

Above mentioned objects are achieved by means of the initially mentioned device, comprising a main part, a light source and a number of contact points, and that the light source is arranged  
20 to emit a light beam with a scattering angle in one plane.

Advantageously the contact points are displaceable and also arranged as attachment devices.

In one preferred embodiment the light beam has a scattering plane essentially parallel to the  
25 alignable plane.

In one most preferred embodiment the device comprises an arm. The arm and the main part are rotatable relative each other. Furthermore, the arm is provided with at least one contact point. Preferably, the contact points are arranged displaceable relative each other and/or  
30 relative the device. The contact points are arranged to take optional positions in a plane, area of which is only limited by the physical dimensions of the device, that these contact points independently of position, allow the device to transfer the position and direction from the

reference plane in two opposite each other essentially perpendicular coordinates.

The system according to the invention comprises a device consisting of a main part, a light source and a number of contact points. The light source is arranged to emit a light beam with a scattering angle in one plane. The system also includes an indicator device to be arranged on the alignable plane.

Suitably, said light beam has a scattering plane essentially parallel to the alignable plane. Preferably, the indicator device consists of a part for attachment and a body provided with a measurement mark. According to the system alignment is achieved when the light beam essentially coincides with the measurement mark. Preferably, at least three indicator devices are arranged on said plane. In one embodiment, the indicator device is part of said plane.

According to a method of the invention for alignment of at least one alignable plane with respect to at least one reference plane so that said planes become essentially plane-parallel, a device is arranged consisting of a main part, a light source and a number of contact points, a light beam is emitted with a scattering angle in one plane, an indicator device is arranged on the alignable plane within the area of the light beam provided with measurement mark, and with respect to the measuring mark adjust the alignable plane is adjusted so that the mark coincides with the intersectional line between the light beam and the indicator device.

### **Brief description of the drawings**

In the following, the invention will be described in greater detail with reference to a non-limiting embodiment shown in attached drawings, in which:

Fig. 1 is a schematic lateral view of an alignment device, according to the invention,

Fig. 2 shows a schematic view in perspective of an application using the device shown in Fig. 1, and

Fig. 3 shows the encircled section of Fig. 2 in greater detail.

**Detailed description of the invention**

A preferred embodiment of an alignment device, according to the invention is shown in Fig. 1. The device 10 comprises a main part 11 and an arm 12. The main part 11 and the arm 12 are rotatably arranged relative each other around an axis 13.

The main part is essentially designed with a first end 14 and a second end 15 connected to each other via a neck 16, which also form an accommodation space 17. The main part 11 further comprises a light source 18 and a possible driving unit 19, optical elements and source of energy (not shown) arranged in a space in the first end 14. The second end is arranged with a journal 13, which pivotally connects the main part 11 to the arm 12. In the neck section 16 the main part is provided with a recess 20, which in this embodiment carries two attachment devices 21a and 21b displaceable relative to the main part. The space 17 is provided to receive the arm 12 when it is rotated therein, which for instance facilitates the handling and the storage of the device.

The arm 12 is also provided with a recess 22 in the direction of its longitudinal axis, which also carries an attachment device 21c displaceable in the recess 22.

Preferably, the attachment devices 21a, 21b and 21c consist of magnets in one end, which can be fixed in the recess by means of a locking device (not shown) for example a nut or the like in a known way. Other additional attachment devices, for example different types of fastening means, suction cups, means for adhesion etc. may also be used. It is also possible to provide separate attachment means and contact points.

Preferably, the light source 18 consists of a laser emitting device, for example a laser diode, but other light sources may also be used. By means of for example optical elements (not shown) the light beam from the light source can be scattered, preferably essentially parallel to that/those planes that must be aligned. The driving unit can also be controlled by means of a switch arranged in the main part (not shown).

An application for alignment and adjustment of two sheaves 23 and 24 is shown in Fig. 2. A

light beam 25 is emitted from the light source 18. This light beam 25 is formed with a relatively large scattering angle in one direction and a very small scattering angle in remaining directions and creates along its extension a plane of light (essentially parallel to the plane of the wheels).

5

The device 10 through the arm 12 is fastened on a reference part which normally consists of one 24 of the two sheaves, for example in a belt transmission. The device is fastened by means of the three attachment devices (or contact points) 21a, 21b and 21c provided with magnets, which take optional positions and are distributed in as great mutual distance as possible and bear on the surface situated close to the periphery of the reference 24. This distributing is enabled through the recesses 20 and 22 and also through the mutual articulated features of the arm 12 and the main part 11 around the axis 13. The plane that the attachment devices form, is limited only by the area of the physical dimensions of the device. These contact points independent of position, allow the device 10 to transfer from the reference plane the position and direction in two to each other essentially perpendicular coordinates.

15

The function of the magnets is now partly to fasten the device onto the reference plane and partly to transfer the position and direction of the reference plane to the light beam 25.

On the other sheave 23 a number of indicator devices 26 are arranged. According to the present, preferred embodiment three indicator devices 26a, 26b and 26c are provided. Each indicator device, of which one is shown in greater detail in Fig. 3, includes an attachment device 27, a body and a reference mark 29 arranged on the body. The attachment device 27 may consist of a magnet or the like. The distance between the mark 29 and the end fixed to the object to be measured of the indicator device preferably corresponds to the distance between the scattering plane of the light beam and the end of the attachment device, which contacts the reference plane.

25

When aligning, the light beam 25 is brought to encounter the indicator devices 26a, 26b and 26c placed on the measured object 23, i.e. the other of the two sheaves in the belt transmission. Because of the essentially great scattering angle of the light beam and the distance to the object to be measured a simultaneous strike of all the indicator devices is

30

enabled. Each mark 29 on each indicator device has a fixed distance from the measuring object 10 and when it is adjusted so that the light beam 25 essentially encounters the centre of these marks 29, the measured object 23 is plane-parallel to and in line with the reference 24. The non plane-parallelism of measured object 23 results in a distance  $l$  between the mark 29 and the point of impact of the light beam (Fig. 3) on each individual indicator device. Plane-parallelism exists when  $l \approx 0$  (or  $l = 0$ ) at each indicator device and the intersectional line of the light beam essentially coincide with the mark 29.

In one embodiment the indicator devices may consist of sensors, which are able to sense the light beam. Preferably the adjustment of the object to be measured can be done automatically so that it is placed plane-parallel with the reference object. Suitably, this can be achieved continuously. In one embodiment a part of the object to be measured may be provided with a reference mark, which is used instead of the indicator devices.

By adjusting the object to be measured 23, advantageously both in axial and radial directions, plane-parallelism is achieved between the sheaves.

While we have illustrated and described a preferred embodiment, according to the invention, it is realized that variations and modifications within the scope of the attached claims may exist. The invention may advantageously be used in all applications where two objects must be aligned plane-parallel or essentially plane-parallel. These objects may also comprise of, for example walls, tabletops, glass, ceilings etc. The design of the device may also be varied by arranging it with three or more arms, or a fixed body provided with a number of recesses in different directions carrying displaceable attachment devices.

Furthermore, the reference marks of the indicator devices may be arranged in the longitudinal direction of the body, whereby plane-parallelism is achieved when an essentially right-angled cross with respect to the intersectional line of the light beam is obtained. Even the light beam may be emitted in the longitudinal direction of the indicator device whereby the reference mark may be arranged along its longitudinal direction or opposite its longitudinal direction.



## CLAIMS

1. A device (10) for alignment of at least one alignable plane with reference to at least one reference plane,  
5 *characterized in,*  
that the device comprises a main part (11), a light source (18) and a number of contact points (21a, 21b, 21c), and that the light source (18) is provided to emit a light beam (25) with a scattering angle in one plane.
- 10 2. A device according to claim 1,  
*characterized in,*  
that the contact points are displaceable.
3. A device according to claim 1 or 2,  
15 *characterized in,*  
that the contact points are arranged as attachment devices.
4. A device according to claim 1 - 3,  
*characterized in,*  
20 that the light beam (25) has a scattering plane essentially parallel to the alignable plane.
5. A device according to any of the preceding claims,  
*characterized in,*  
that the device comprises an arm (12), and that the arm (12) and the main part (11) are  
25 rotatable relative each other.
6. A device according to claim 5,  
*characterized in,*  
that the arm (12) is provided with at least one contact point (21c).  
30
7. A device according to any of the preceding claims,  
*characterized in,*

that the contact points are arranged displaceable relative each other and/or relative the device.

8. A device according to any of the preceding claims,  
*characterized in,*

5 that the contact points are arranged to take optional positions in a plane, limited only by an area of the physical dimensions of the device, that the contact points independent of position, allow the device (10) to transfer a position and direction from the reference plane in two relative each other essentially perpendicular coordinates.

10 9. A device according to any of the preceding claims,  
*characterized in,*

that the reference plane and the alignable plane are sheaves, wheels, walls or the like.

15 10. A system for alignment of at least one alignable plane with reference to at least one reference plane,  
*characterized in,*

that the system comprises:

- a device (10) consisting of a main part (11), a light source (18) and a number of contact points (21a, 21b, 21c), which light source (18) is arranged to emit a light beam  
20 (25) with a scattering angle in one plane, and
- indicator devices (26a, 26b, 26c) intended to be arranged onto the alignable plane.

11. The system according to claim 10,  
*characterized in,*

25 that the light beam (25) from the light source has a scattering plane essentially parallel to the alignable plane.

12. The system according to claim 10 or 11,  
*characterized in,*

30 that the indicator device comprises a part for attachment (27) and a body provided with a measurement mark (29).

13. The system according to claim 12,

*characterized in,*

that alignment is achieved when the light beam essentially coincides with the measurement mark (29).

5

14. The system according to any of the claims 10-13,

*characterized in,*

that at least three indicator devices are arranged on said plane.

10

15. The system according to any of the claims 10-13,

*characterized in,*

that the indicator device is part of said plane.

15

16. A method for alignment of at least one alignable plane with reference to at least one

reference plane so that said planes become essentially plane-parallel,

*characterized in,*

that the method includes the steps of:

- providing a device (10) comprising a main part (11), a light source (18) and a number of contact points (21a, 21b, 21c),
- 20 – emitting a light beam (25) with a scattering angle in one plane,
- arranging on said alignable plane within the area of the light beam indicator devices (26a, 26b, 26c) provided with measurement marks (29), and
- adjusting the alignable plane with regard to the measuring marks so that each mark coincides with an intersectional line between the light beam and the indicator device.

25

1/2

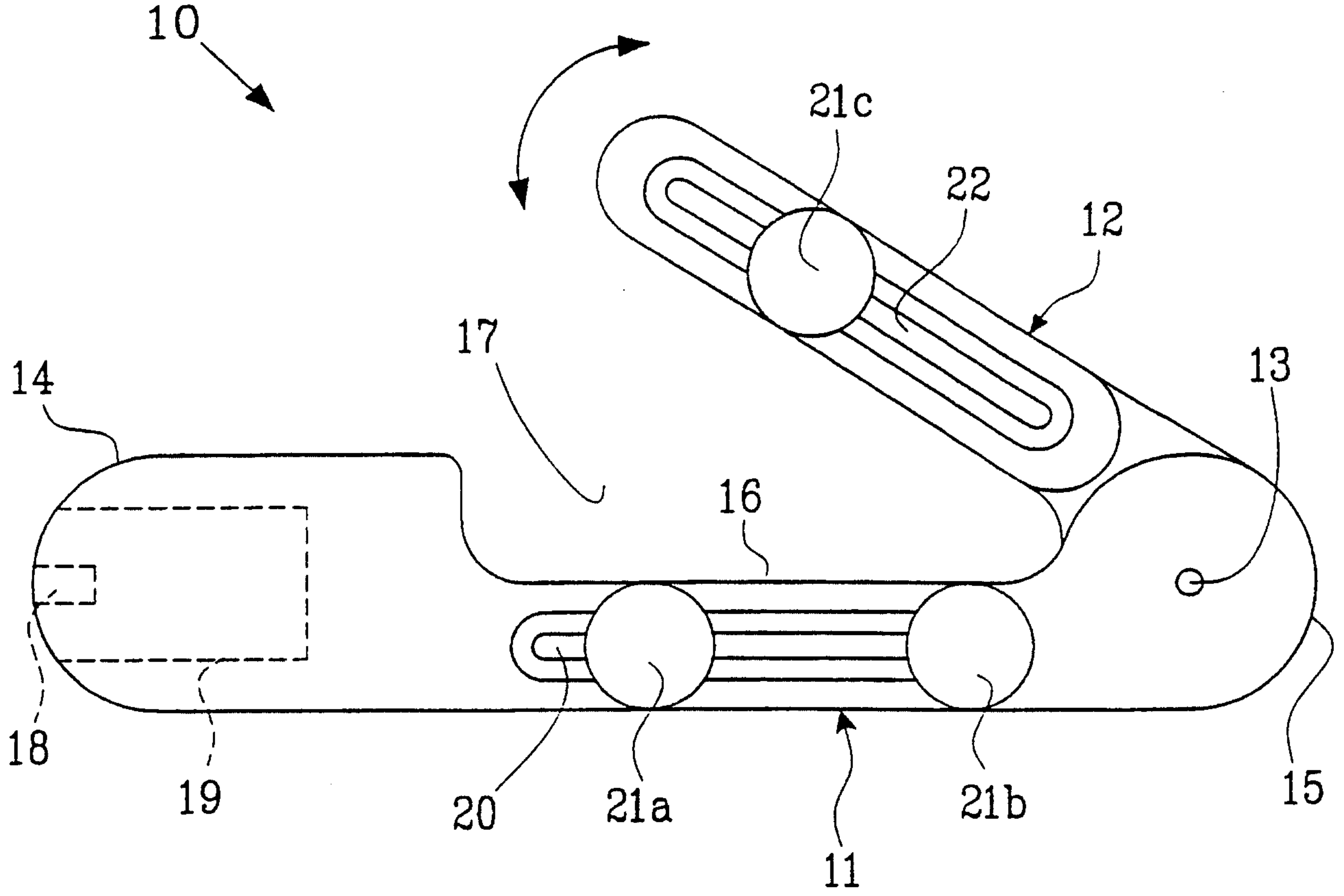

FIG. 1

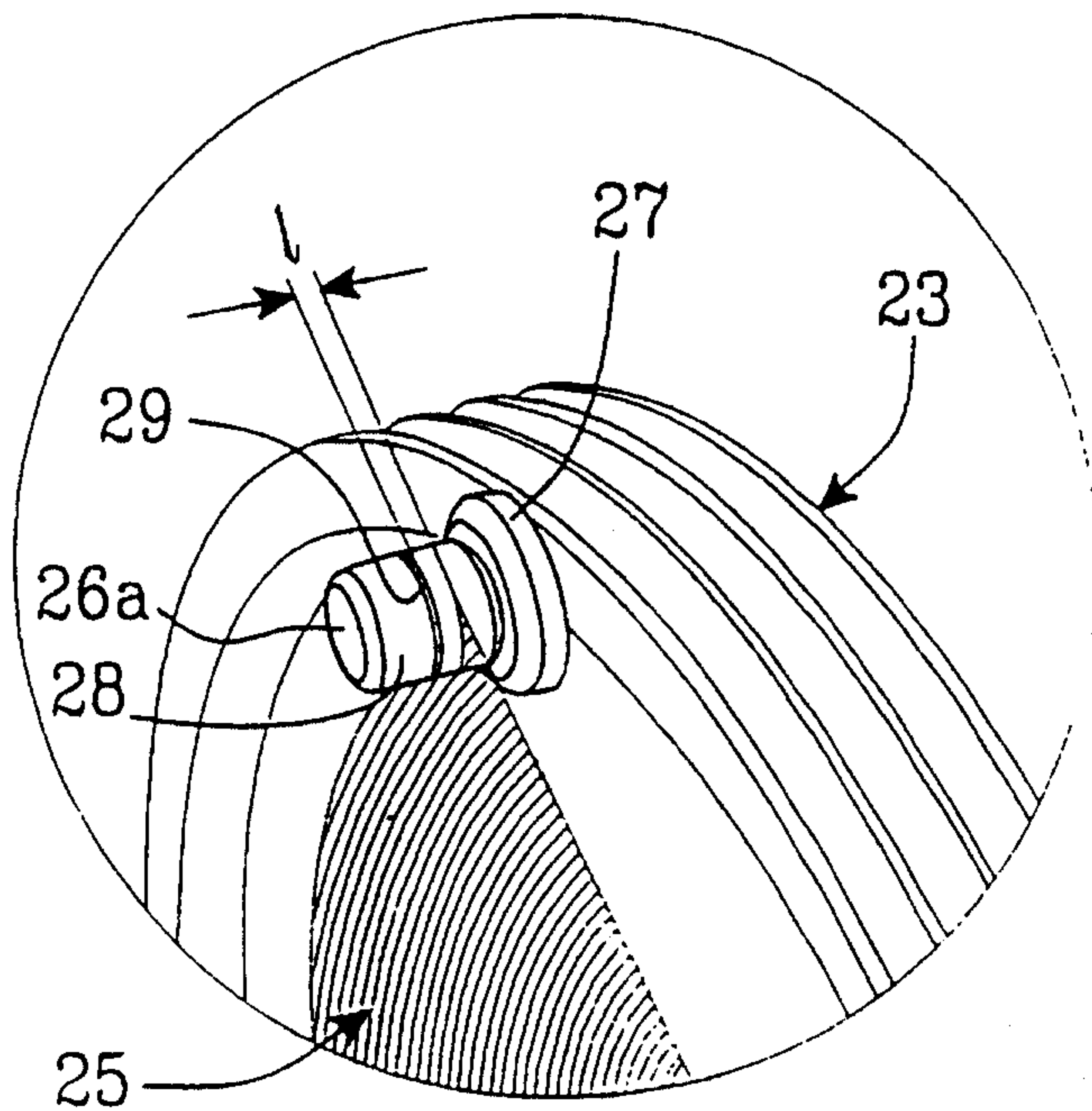

FIG. 3

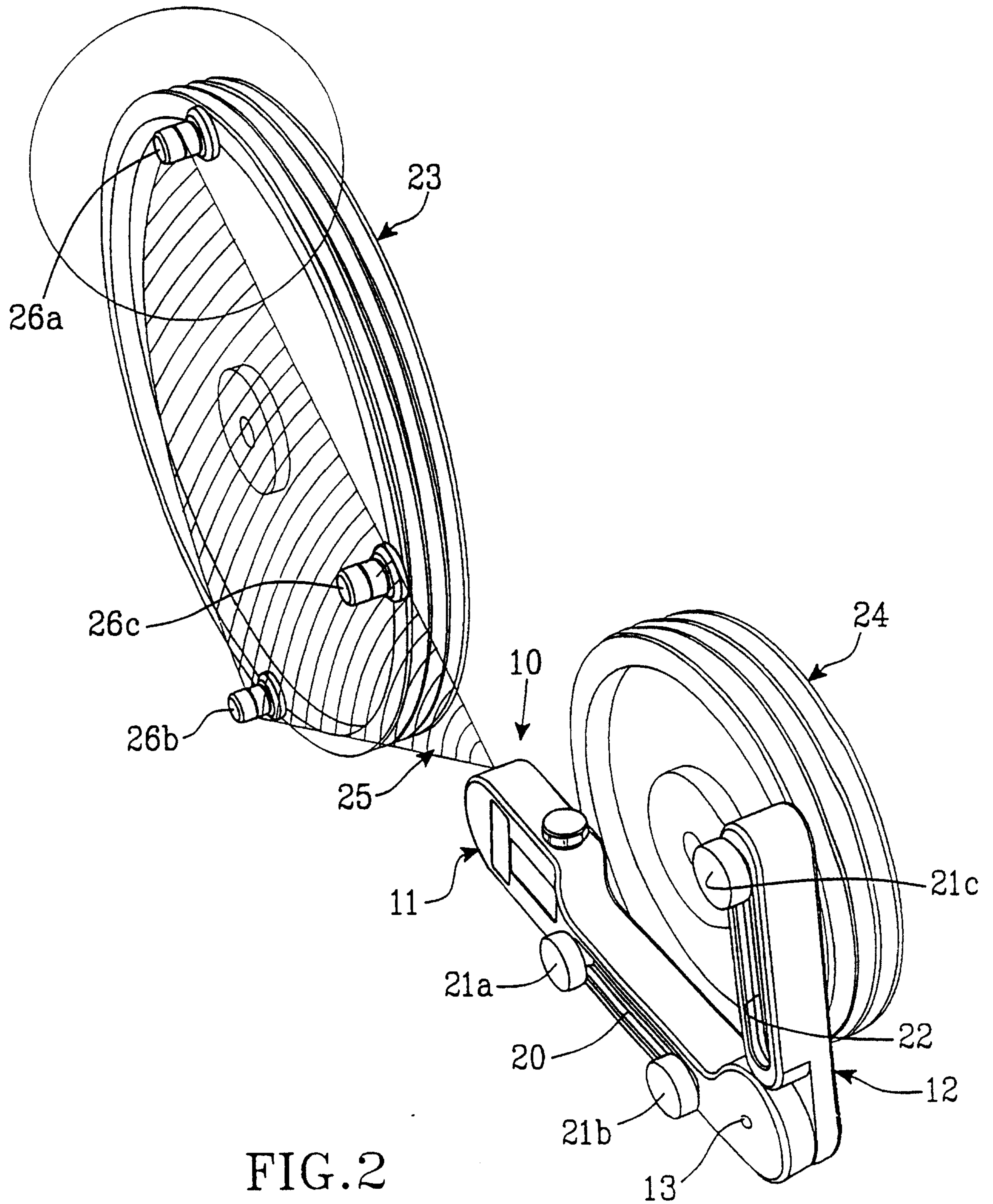

FIG. 2

