



US00D974830S

(12) **United States Design Patent**
Peng

(10) **Patent No.:** **US D974,830 S**

(45) **Date of Patent:** **** Jan. 10, 2023**

(54) **LID FOR WATER BOTTLE**
(71) Applicant: **Shenzhen Too Feel Plastic & Hardware Co., Ltd**, Guangdong (CN)

D775,950 S * 1/2017 Rognard D9/434
D778,117 S * 2/2017 Du D7/608
D780,517 S * 3/2017 Boroski D7/529
D818,767 S * 5/2018 Nezu D7/392.1

(Continued)

(72) Inventor: **Guo Peng**, Guangdong (CN)
(73) Assignee: **Shenzhen Too Feel Plastic & Hardware Co., Ltd**, Shenzhen (CN)

FOREIGN PATENT DOCUMENTS

CN 307017337 * 12/2021
CN 307415204 * 6/2022

(Continued)

(**) Term: **15 Years**
(21) Appl. No.: **29/760,491**

OTHER PUBLICATIONS

Opard [online] URL: <https://www.amazon.com/Opard-Sports-Reusable-Plastic-Outdoor/dp/B0897NQR6C> (site visited: May 31, 2022) (Year: 2020).*

(Continued)

(30) **Foreign Application Priority Data**
Jul. 22, 2020 (CN) 202030401906.0

Primary Examiner — Jae Liang
Assistant Examiner — Tia Ruth-Renee Polidori

(51) **LOC (14) Cl.** **07-01**
(52) **U.S. Cl.**
USPC **D7/392.1; D7/396.2**

(57) **CLAIM**

The ornamental design for a lid for water bottle, as shown and described.

(58) **Field of Classification Search**
USPC D7/507, 509, 510, 511, 533, 536, 392.1, D7/396.1, 396.2, 608, 900; D30/132, D30/121, 122, 123, 124, 125, 126, 127, D30/128, 129, 130, 131, 133; D9/443, D9/449, 561; D3/202; D29/125, 126
CPC A47G 19/2205; A47G 23/16; A47G 19/2272; A47J 41/00; A47J 41/02; A47J 41/0077; Y10S 220/903; B65D 21/02; B65D 43/00; B65D 41/00
See application file for complete search history.

DESCRIPTION

FIG. 1 is a front, top and right side perspective view of a lid for water bottle showing my new design;
FIG. 2 is a rear, top and left side perspective view thereof;
FIG. 3 is a front, bottom and left side perspective view thereof;
FIG. 4 is a front elevational view thereof;
FIG. 5 is a rear elevational view thereof;
FIG. 6 is a left side view thereof;
FIG. 7 is a right side view thereof;
FIG. 8 is a top plan view thereof; and,
FIG. 9 is a bottom plan view thereof.

The broken lines in the drawings illustrate portions of the lid for water bottle which form no part of the claimed design.

(56) **References Cited**
U.S. PATENT DOCUMENTS

D590,661 S * 4/2009 Kitamura D7/510
RE42,484 E * 6/2011 Kitamura D7/510
D747,918 S * 1/2016 Herbst D7/392.1
D770,222 S * 11/2016 Boroski D9/449

1 Claim, 9 Drawing Sheets

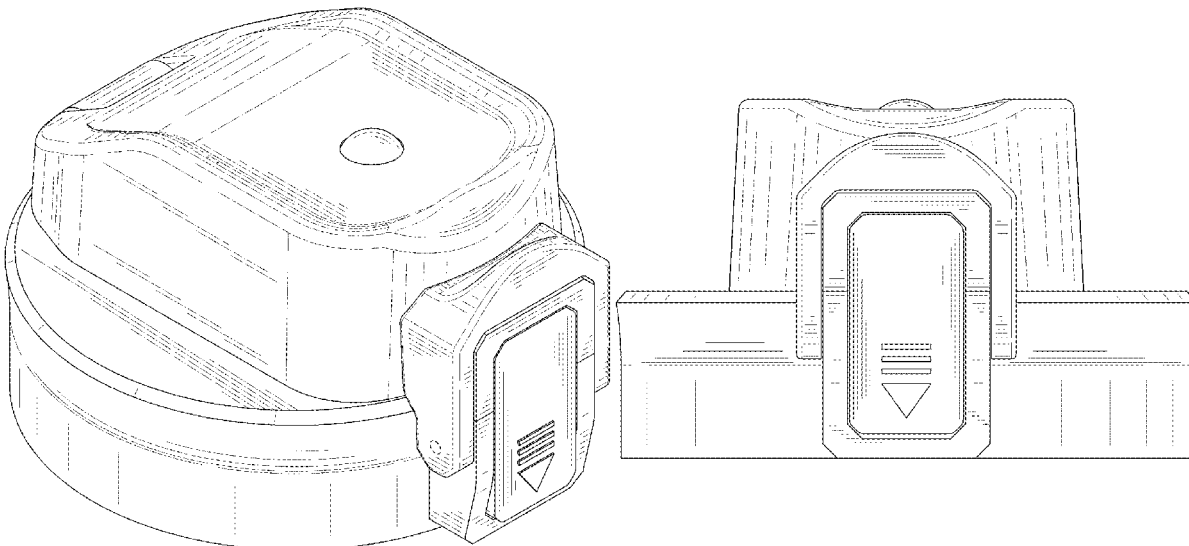

(56)

References Cited

U.S. PATENT DOCUMENTS

D842,645 S * 3/2019 Horimoto D7/391
 D853,784 S * 7/2019 Wu D7/392.1
 D869,230 S * 12/2019 Hao D9/449
 D892,557 S * 8/2020 Wang D7/510
 D892,558 S * 8/2020 Wang D7/529
 D902,648 S * 11/2020 Wang D9/449
 D909,128 S * 2/2021 Hu D7/396.2
 D942,212 S * 2/2022 Zhou D7/392.1
 D942,808 S * 2/2022 Wang D7/392.1
 D943,343 S * 2/2022 Wang D7/392.1
 D947,597 S * 4/2022 Shi D7/392.1
 D950,307 S * 5/2022 Peng D7/392.1
 D951,025 S * 5/2022 Zheng D7/510
 D951,700 S * 5/2022 Chen D9/449
 D951,701 S * 5/2022 Zhang D7/392.1
 D951,713 S * 5/2022 Qiu D7/510
 D952,405 S * 5/2022 Peng D7/510
 D957,185 S * 7/2022 Chen D9/449
 D957,186 S * 7/2022 Wang D7/392.1
 D957,885 S * 7/2022 Zhang D7/510

D958,591 S * 7/2022 Hu D7/392.1
 D958,592 S * 7/2022 Zhou D7/392.1
 2017/0267423 A1* 9/2017 Maruyama A47G 19/2288

FOREIGN PATENT DOCUMENTS

CN 307433710 * 7/2022
 CN 307508751 * 8/2022
 GB 6217295 * 7/2022
 JP D1677585 * 1/2021
 KR 301030548.0000 * 11/2019

OTHER PUBLICATIONS

Venture Pal [online] URL: <https://www.amazon.com/Venture-Pal-Motivational-Bottle-Marker/dp/B08HLLHGTN> (site visited: May 31, 2022) (Year: 2020).*

Gohippos [online] URL: <https://www.amazon.com/dp/B09GDVWCWF> (site visited: May 31, 2022) (Year: 2021).*

Under Armour [online] URL: <https://www.amazon.com/ARMOUR-Beyond-Gradient-Breeze-Chrome/dp/B08TR5PHCM> (site visited: Sep. 16, 2022) (Year: 2021).*

* cited by examiner

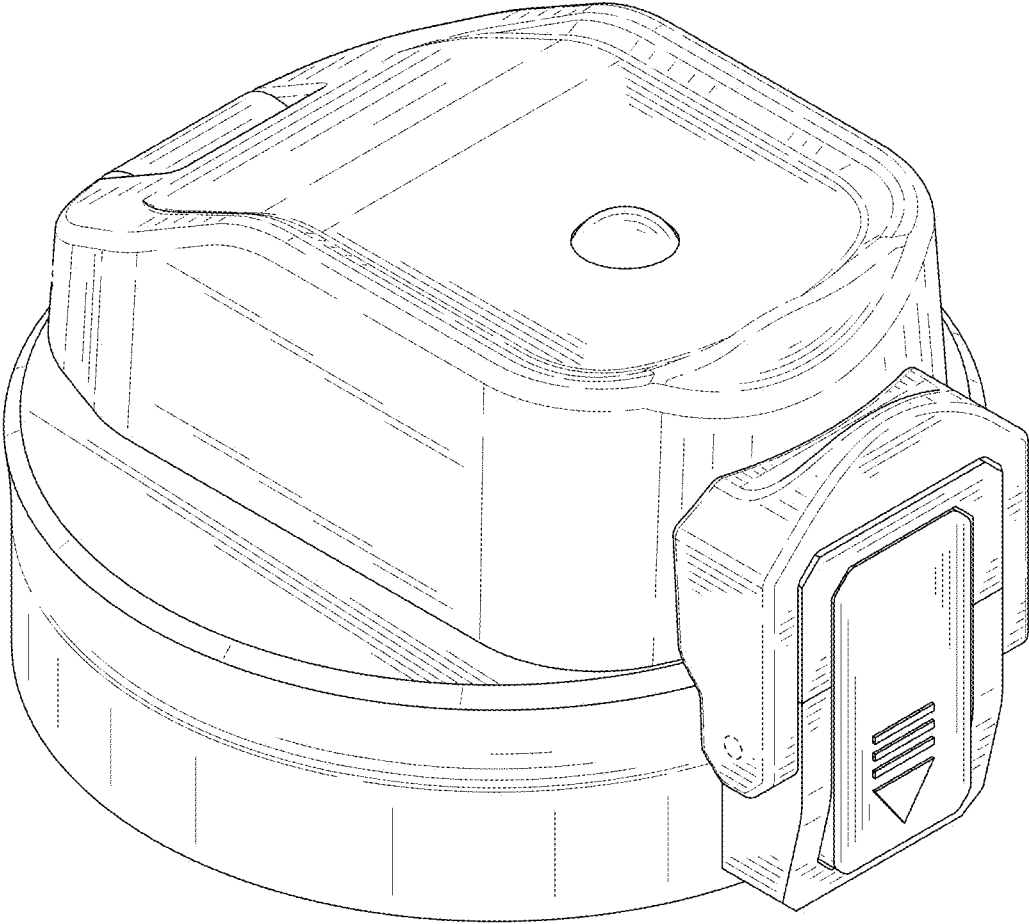

FIG. 1

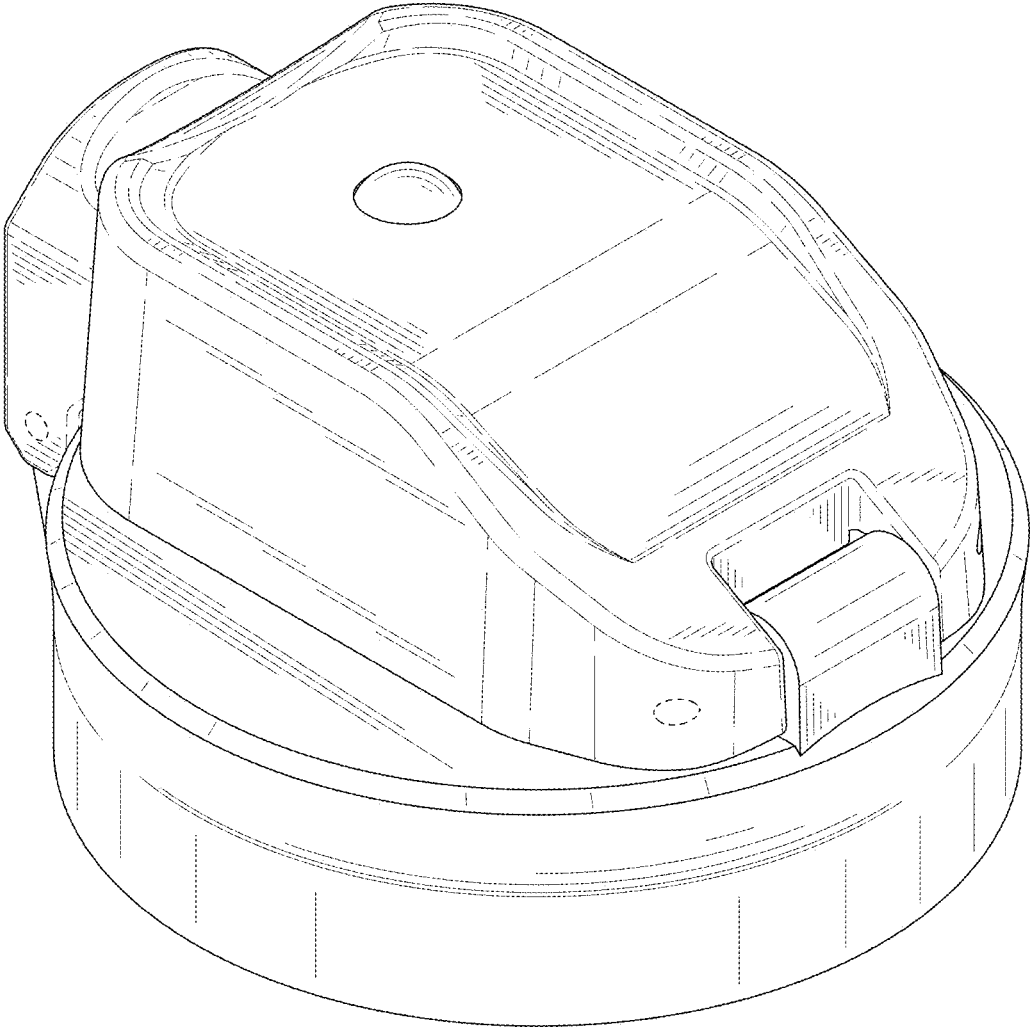

FIG. 2

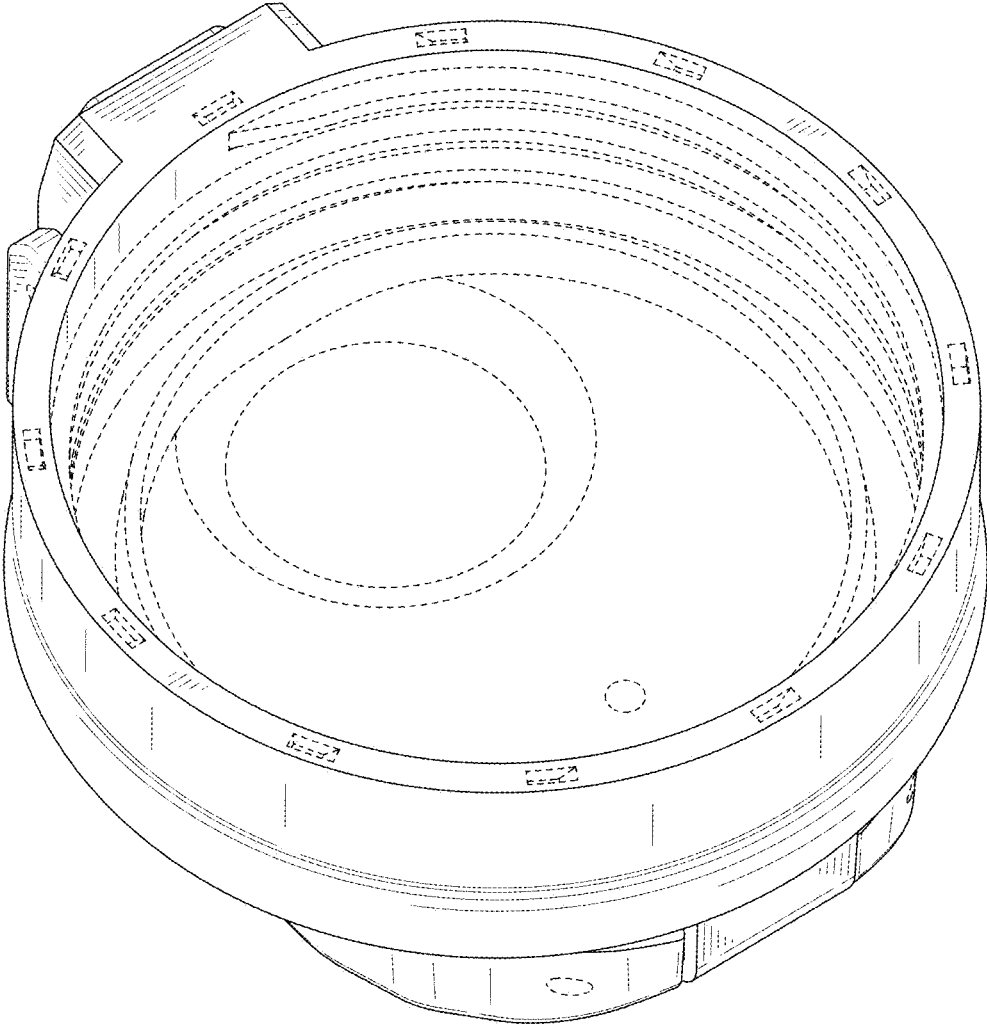

FIG. 3

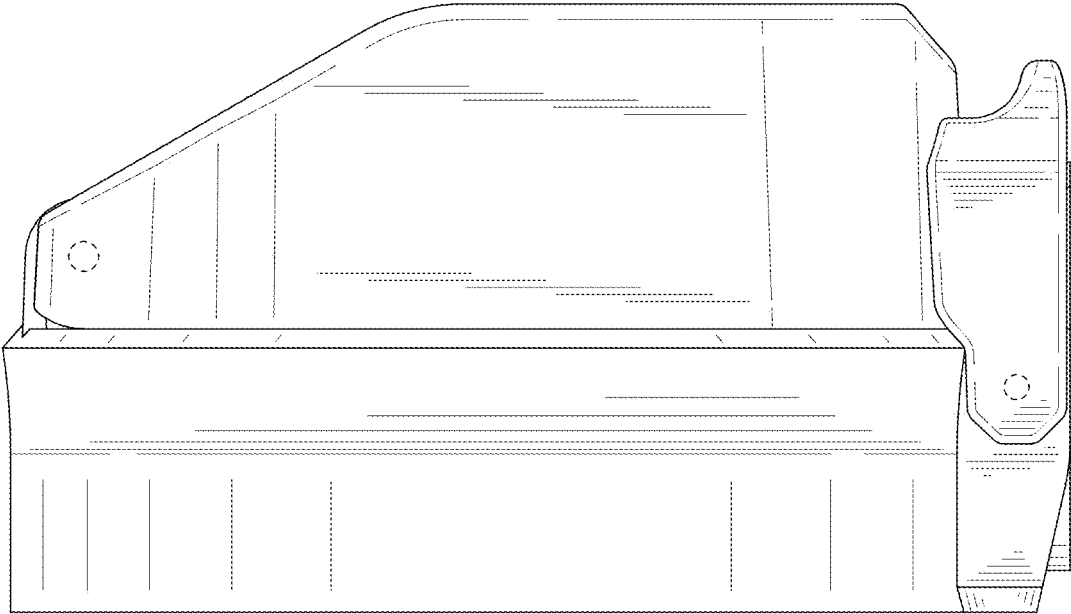

FIG. 4

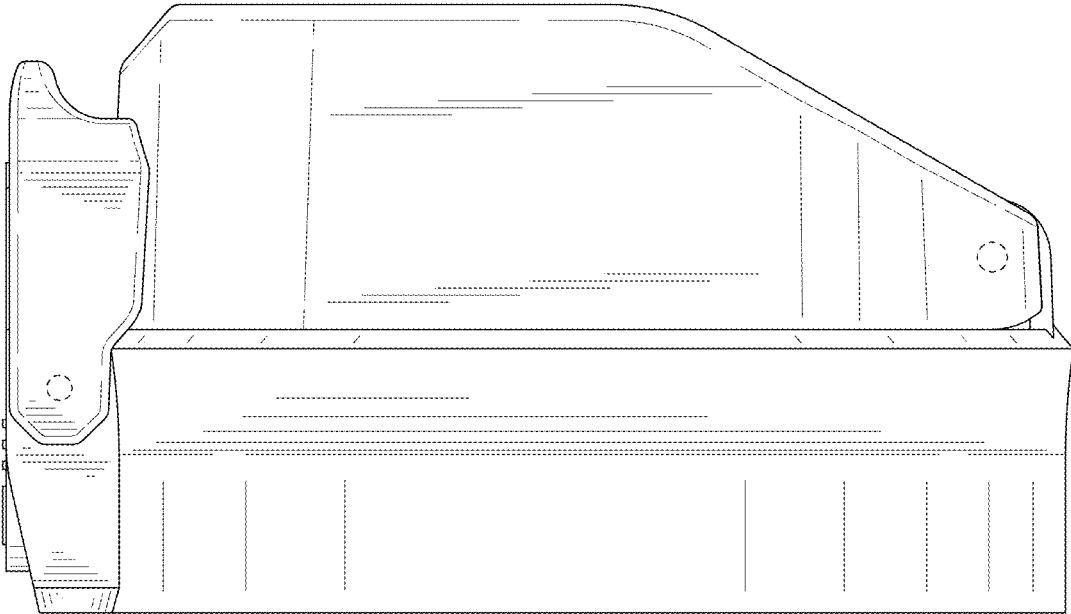

FIG. 5

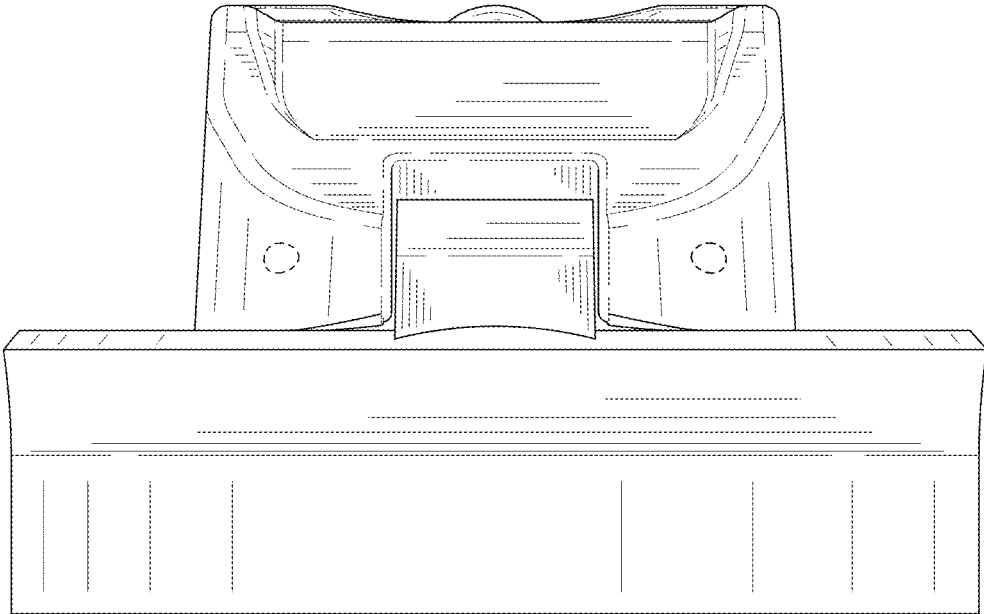

FIG. 6

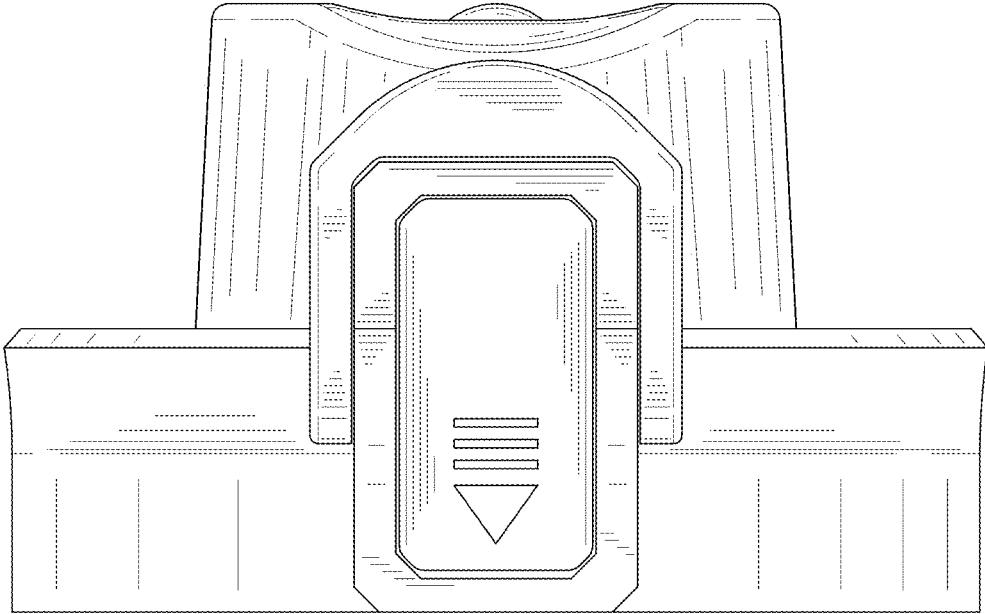

FIG. 7

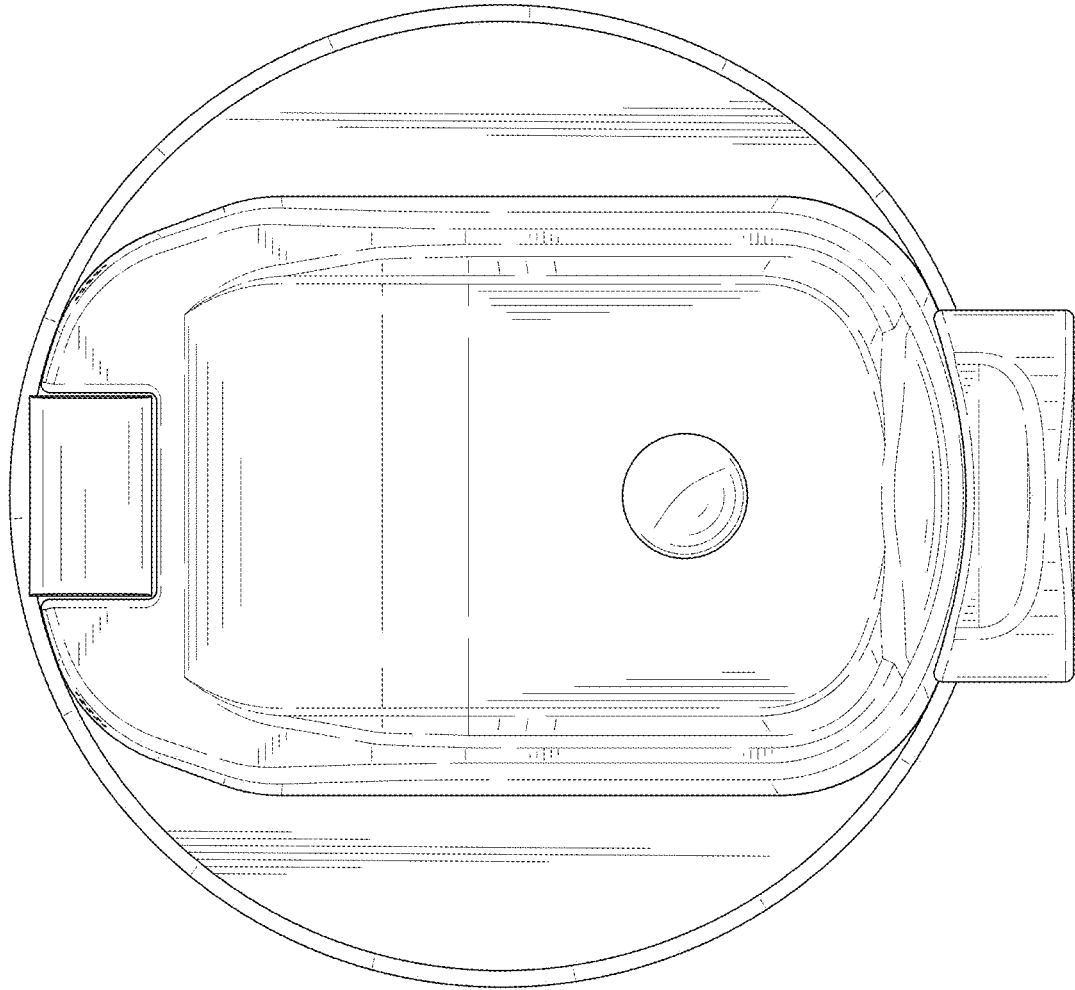

FIG. 8

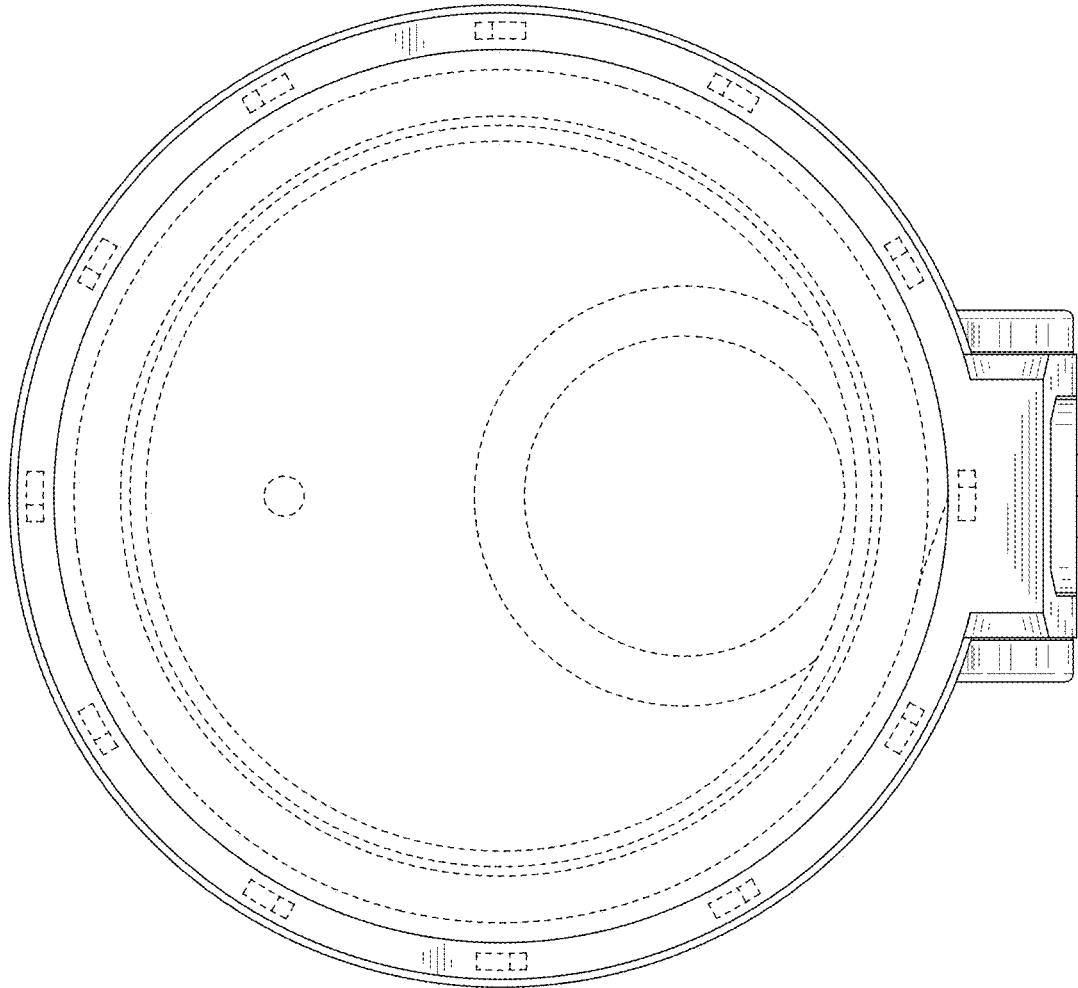

FIG. 9