



US00D583395S

(12) **United States Design Patent**
Ueda

(10) **Patent No.:** **US D583,395 S**

(45) **Date of Patent:** **** Dec. 23, 2008**

(54) **COVER FOR A HEATER STAGE OF A PLASMA PROCESSING APPARATUS**

6,093,583 A * 7/2000 Mukerji et al. 438/113
D442,864 S * 5/2001 Davies D9/454

(75) Inventor: **Atsushi Ueda**, Amagasaki-shi (JP)

FOREIGN PATENT DOCUMENTS

(73) Assignee: **Tokyo Electron Limited**, Tokyo (JP)

EP	0592017 A2 *	4/1994
JP	D1197395	12/2003
JP	2004-307939	11/2004
KR	30-0411787	4/2006
TW	596249	6/2004
TW	D110109	4/2006
TW	D113217	10/2006

(**) Term: **14 Years**

(21) Appl. No.: **29/281,073**

* cited by examiner

(22) Filed: **Jun. 14, 2007**

(30) **Foreign Application Priority Data**

Primary Examiner—Sandra Snapp

Dec. 15, 2006 (JP) 2006-034517

Assistant Examiner—Patricia Palasik

(51) **LOC (8) Cl.** **15-09**

(74) *Attorney, Agent, or Firm*—Oblon, Spivak, McClelland, Maier & Neustadt, P.C.

(52) **U.S. Cl.** **D15/138; D15/199**

(57) **CLAIM**

(58) **Field of Classification Search** None
See application file for complete search history.

The ornamental design for a cover for a heater stage of a plasma processing apparatus, as shown.

(56) **References Cited**

DESCRIPTION

U.S. PATENT DOCUMENTS

D239,437 S *	4/1976	Boduch	D9/445
4,048,845 A *	9/1977	Gilbert	73/45.5
4,122,964 A *	10/1978	Morris	215/260
4,213,537 A *	7/1980	Caccavale	220/215
D265,176 S *	6/1982	Bock	D9/454
4,779,748 A *	10/1988	King	215/256
D309,109 S *	7/1990	Allen	D9/436
4,978,567 A *	12/1990	Miller	428/157
D315,309 S *	3/1991	Baughman	D9/456
D328,837 S *	8/1992	Marsten et al.	D7/585
5,209,601 A *	5/1993	Odill et al.	404/26
5,354,626 A *	10/1994	Kobayashi et al.	429/30
D357,385 S *	4/1995	Addison et al.	D7/407
5,595,496 A *	1/1997	Konda et al.	439/271
D386,792 S *	11/1997	Miller	D20/21
5,771,576 A *	6/1998	Braxton et al.	29/868
D399,245 S *	10/1998	Harden	D18/15

FIG. 1 is a front view of a cover for a heater stage of a plasma processing apparatus showing my new design;

FIG. 2 is a rear view thereof;

FIG. 3 is a right side view thereof;

FIG. 4 is a top plan view thereof;

FIG. 5 is a sectional view taken along line 5—5 of FIG. 1 thereof;

FIG. 6 is an enlarged view taken along line 6—6 of FIG. 5 thereof;

FIG. 7 is an enlarged view taken along line 7—7 of FIG. 5 thereof; and,

FIG. 8 is a perspective view thereof.

1 Claim, 3 Drawing Sheets

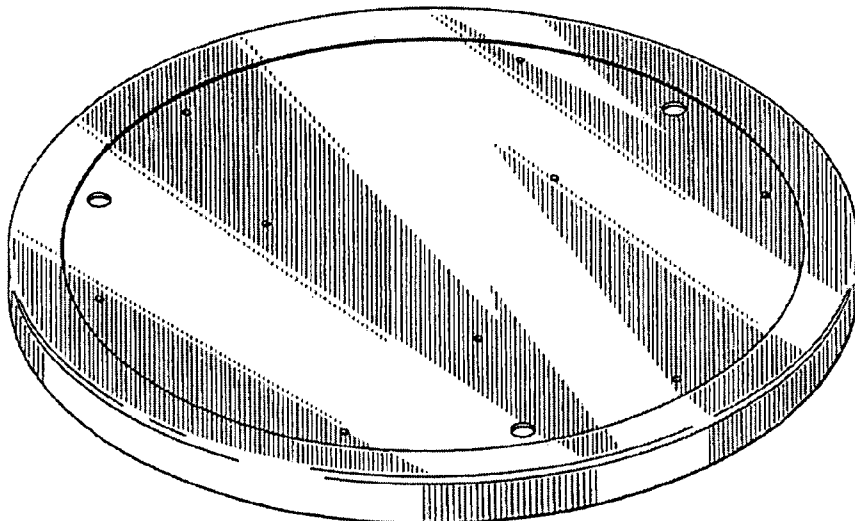

FIG.1

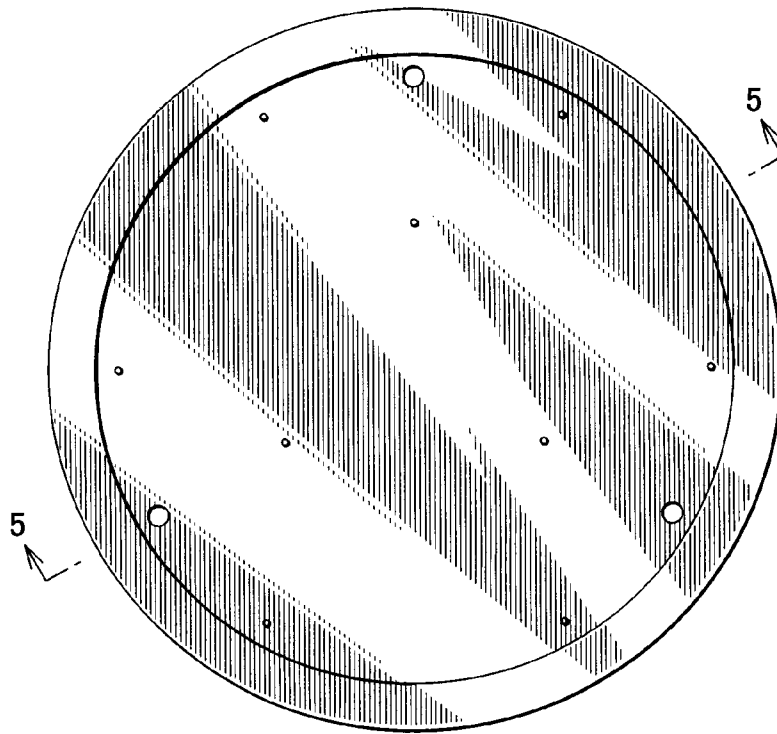

FIG.2

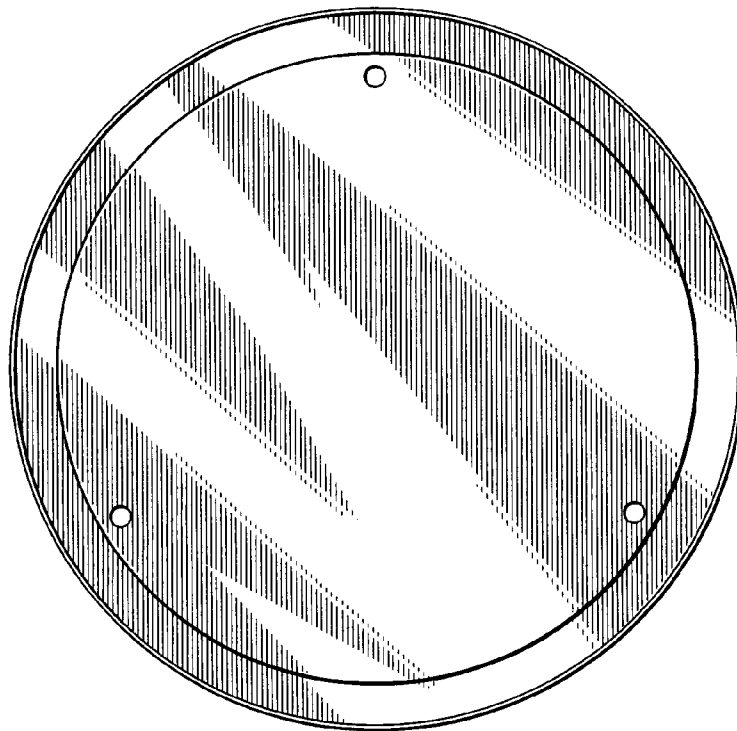

FIG.3



FIG.4

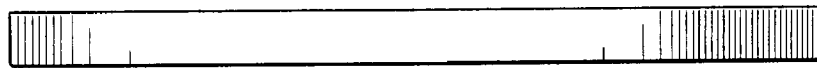

FIG.5

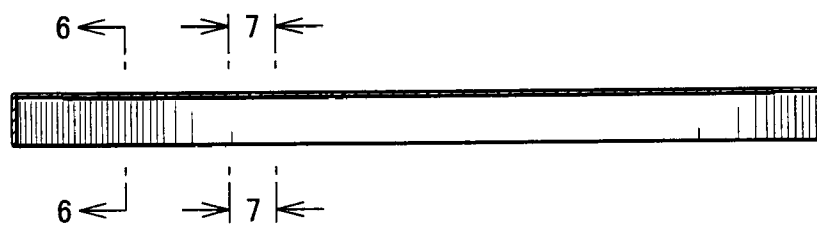

FIG.6

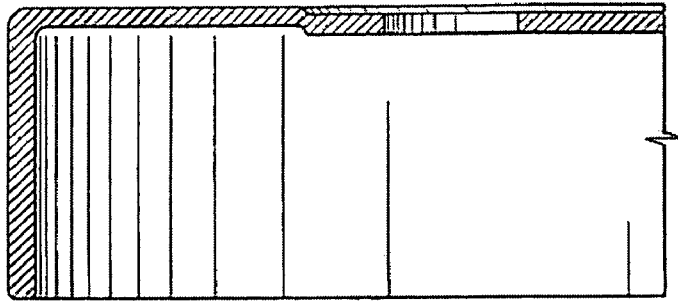

FIG.7

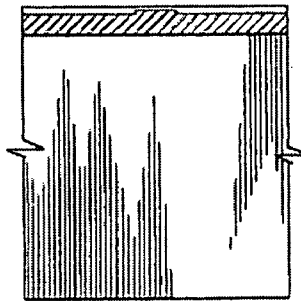
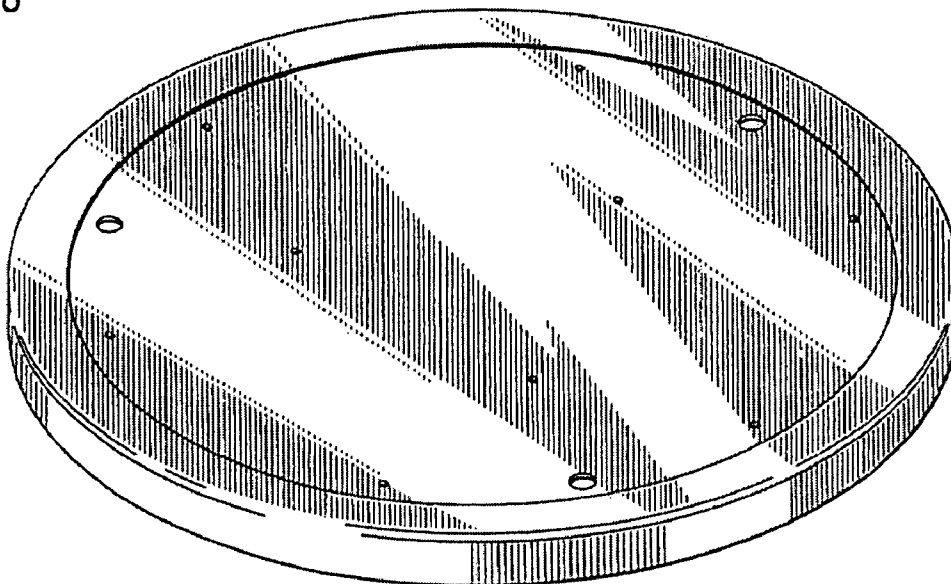

FIG.8



UNITED STATES PATENT AND TRADEMARK OFFICE
CERTIFICATE OF CORRECTION

PATENT NO. : Des. 583,395 S
APPLICATION NO. : 29/281073
DATED : December 23, 2008
INVENTOR(S) : Ueda

Page 1 of 1

It is certified that error appears in the above-identified patent and that said Letters Patent is hereby corrected as shown below:

On the title page, the Terminal Disclaimer information has been omitted. The Notice information and Item (45) should read as follows:

Title Page should read

Item (45) **Date of Patent: ** * Dec. 23, 2008**

-- (*) Notice: This patent is subject to a terminal disclaimer.

(**) Term: 14 Years--

Signed and Sealed this

Thirty-first Day of March, 2009

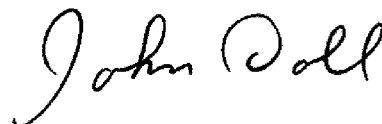

JOHN DOLL
Acting Director of the United States Patent and Trademark Office