



US00D911929S

(12) **United States Design Patent**  
**Brockie**

(10) **Patent No.:** **US D911,929 S**

(45) **Date of Patent:** **\*\* Mar. 2, 2021**

(54) **BATTERY PACK**

(71) Applicant: **Theta Consulting LLC**, Clearwater Beach, FL (US)

(72) Inventor: **Craig Brockie**, Clearwater Beach, FL (US)

(\*\*) Term: **15 Years**

(21) Appl. No.: **29/702,250**

(22) Filed: **Aug. 17, 2019**

(51) **LOC (13) Cl.** ..... **13-02**

(52) **U.S. Cl.**  
USPC ..... **D13/103**

(58) **Field of Classification Search**

USPC ..... D13/102-108, 110, 118, 119, 184, 199, D13/154, 156  
CPC ..... Y02E 60/10; Y02E 60/12; Y02E 60/122; Y02E 60/124; Y02E 60/50; H01M 2/02; H01M 2/022; H01M 2/0202; H01M 2/0207; H01M 2/0212; H01M 2/1061; H01M 2/1022; H01M 2/1055; H01M 2/1066; H01M 2/105; H01M 2/20; H01M 2/202; H01M 2/204; H01M 2/206; H01M 10/44; H01M 10/46; H01M 10/465; H01M 10/482; H01M 10/4257; H01M 10/0436; H01M 10/48; H01M 2200/30; H01M 2250/30; H01M 2250/40; H02J 7/00; H02J 7/0003; H02J 7/0011; H02J 7/0013; H02J 7/0054; H02J 7/0055; H02J 7/0057; H02J 2007/0062; H02G 15/18; H02G 15/1826; H01R 13/516; H01R 13/518; H01R 13/52; H01R 13/46; H01R 13/50; H01R 13/506; H01R 13/5213  
See application file for complete search history.

(56) **References Cited**

**U.S. PATENT DOCUMENTS**

D598,844 S \* 8/2009 Harrison ..... D13/103  
D630,359 S \* 1/2011 Kang ..... D26/61

D670,244 S \* 11/2012 Workman ..... D13/110  
D674,746 S \* 1/2013 Zhang ..... D13/102  
D686,155 S \* 7/2013 Nguyen ..... D13/103  
D824,063 S \* 7/2018 Hutchens ..... D26/60  
D835,578 S \* 12/2018 Bai ..... D13/108  
D836,225 S \* 12/2018 Finch ..... D26/28  
D840,079 S \* 2/2019 Marshall ..... D26/60  
D851,589 S \* 6/2019 Fiste ..... D13/108  
D852,136 S \* 6/2019 Yoshida ..... D13/108  
D861,622 S \* 10/2019 Lawrence ..... D13/184  
D866,461 S \* 11/2019 Arimoto ..... D13/108  
D867,630 S \* 11/2019 Benoit ..... D26/28  
D869,036 S \* 12/2019 Brockie ..... D26/60  
D870,659 S \* 12/2019 Liao ..... D13/108  
2009/0040752 A1 \* 2/2009 Dallas ..... H01M 2/1055  
362/202

\* cited by examiner

*Primary Examiner* — Christy Nemeth

(74) *Attorney, Agent, or Firm* — Au LLC; Adam E. Urbanczyk

(57) **CLAIM**

The ornamental design for a battery pack, as shown and described.

**DESCRIPTION**

FIG. 1 is a left perspective view of a battery pack in a secured position;  
FIG. 2 is a left side view thereof;  
FIG. 3 is a right side view thereof;  
FIG. 4 is a rear view thereof;  
FIG. 5 is a front view thereof;  
FIG. 6 is a top view thereof; and  
FIG. 7 is a bottom view thereof; and,  
FIG. 8 is a left perspective view of a battery pack in an unsecured position.  
The broken lines illustrating a wheel hub in FIGS. 1-7 are for the purpose of illustrating environmental subject matter that forms no part of the claimed design.

**1 Claim, 8 Drawing Sheets**

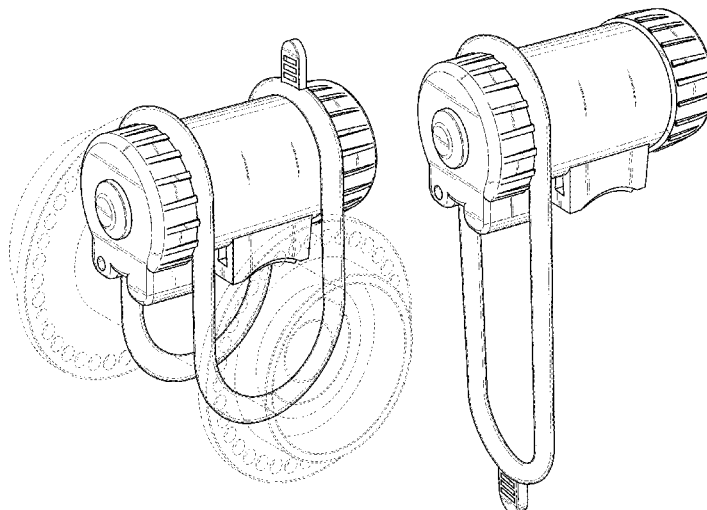

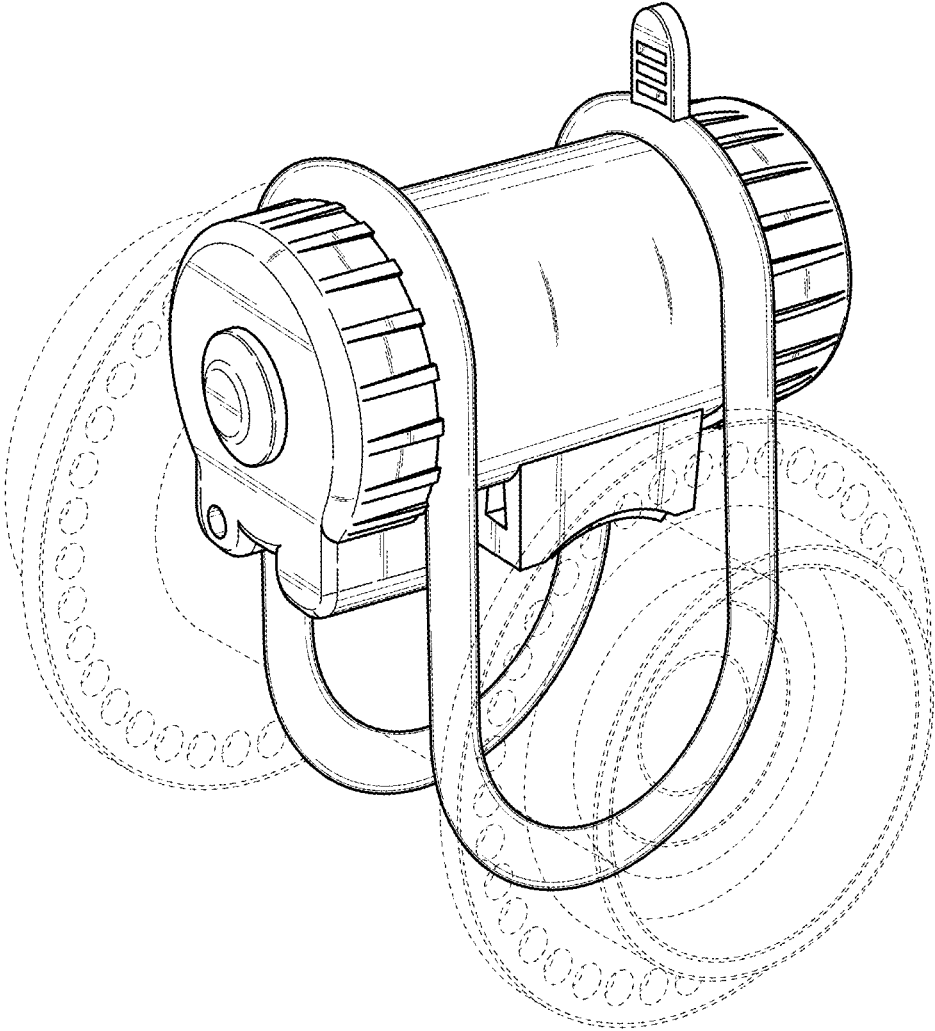

FIG. 1

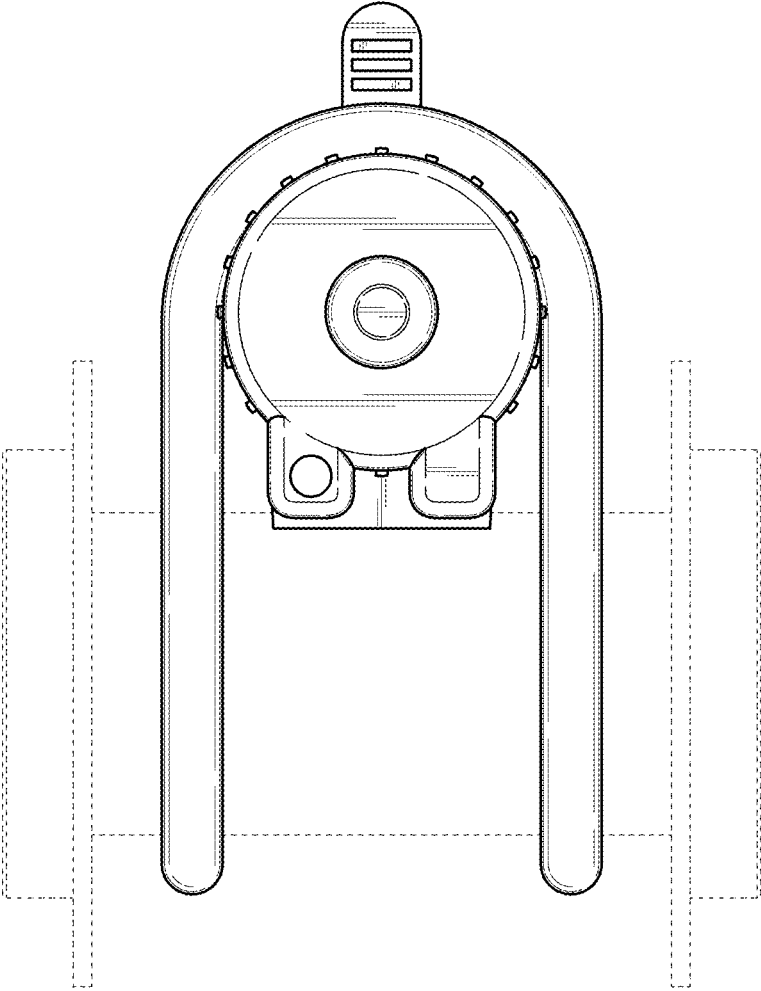

FIG. 2

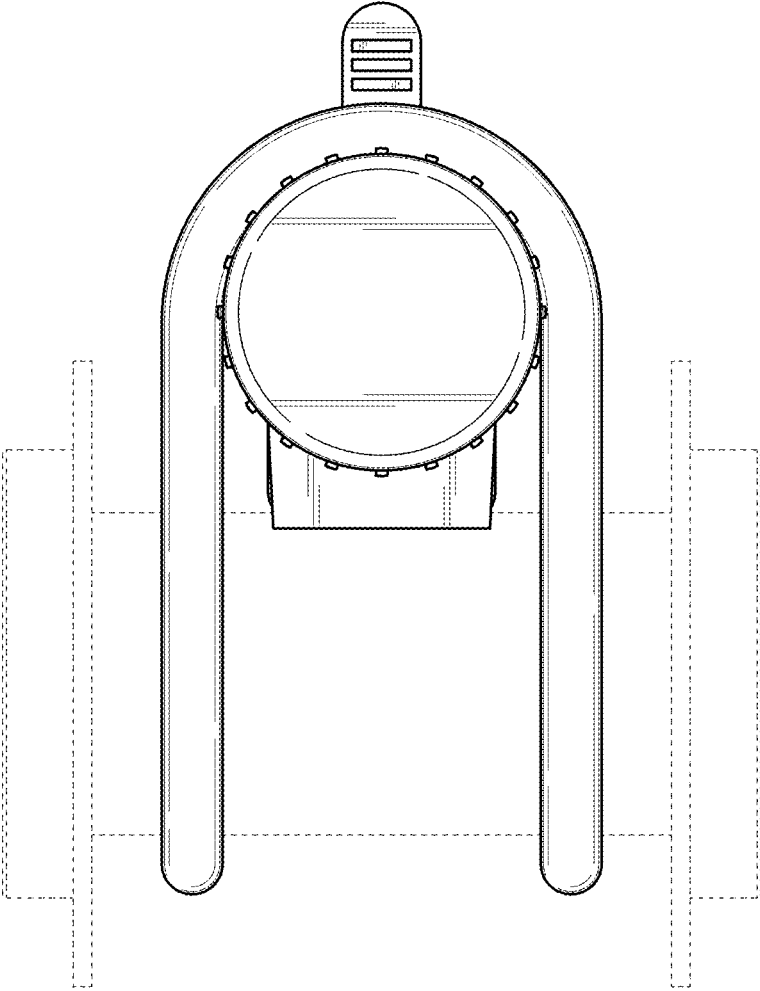

FIG. 3

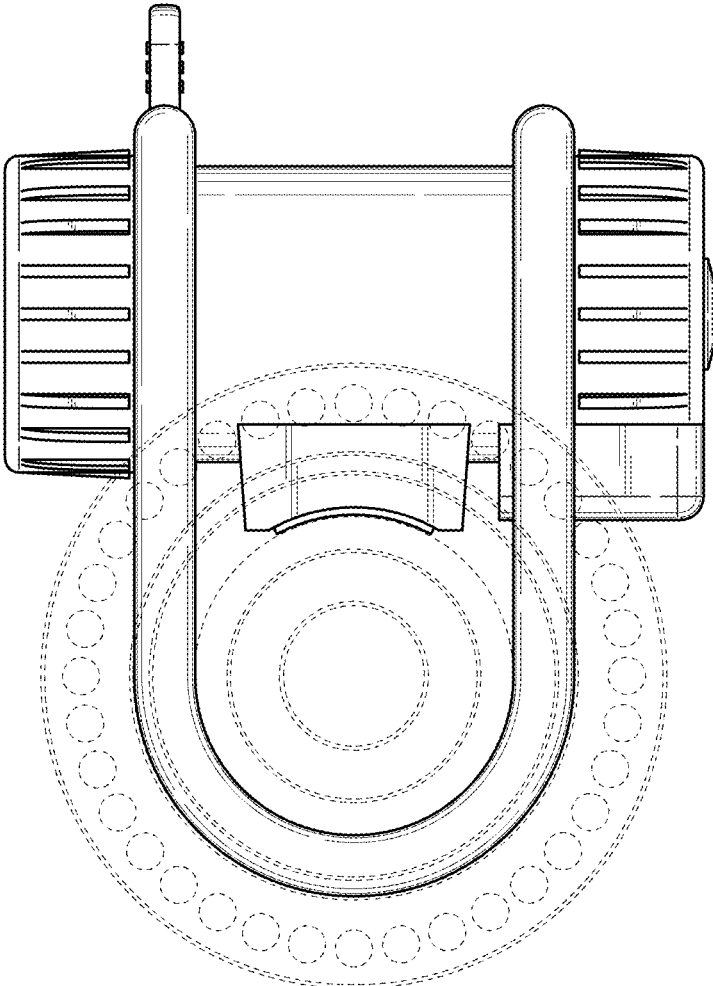

FIG. 4

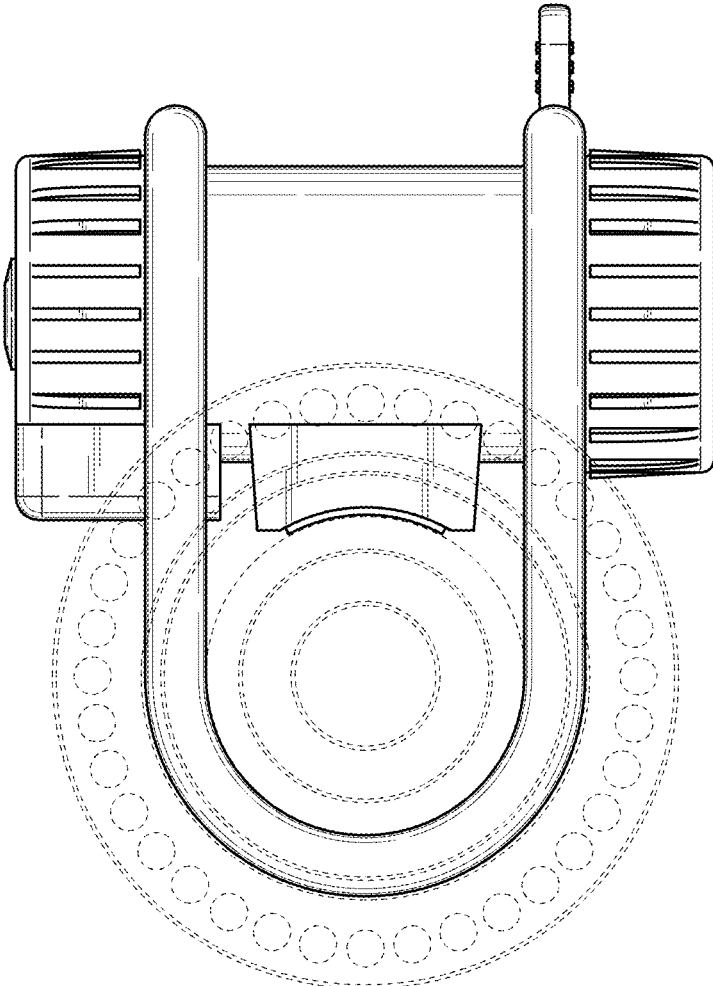

FIG. 5

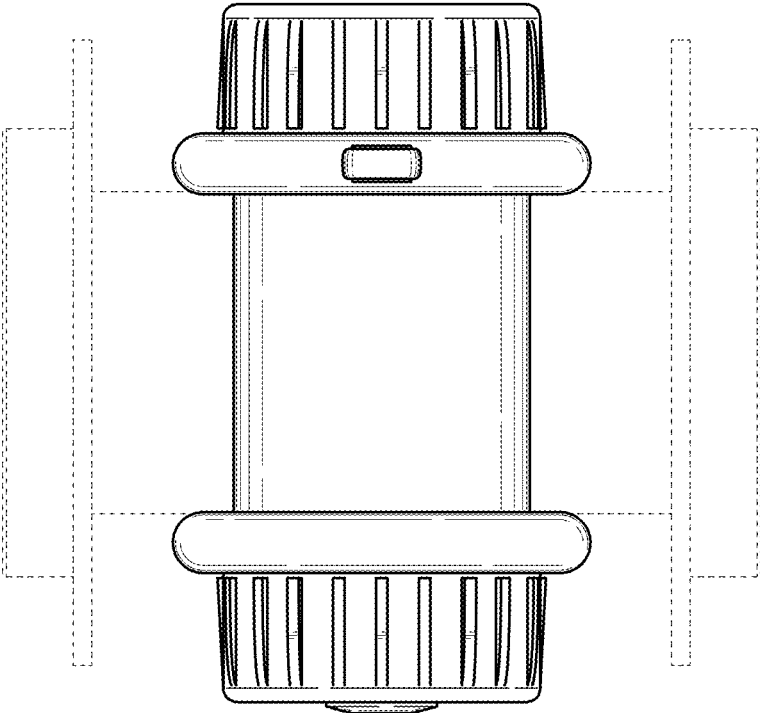

FIG. 6

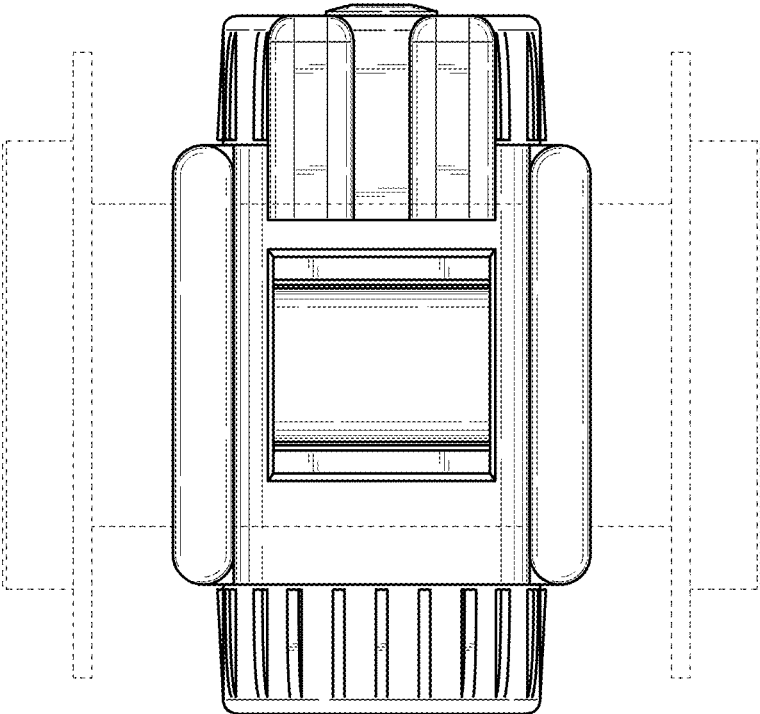

FIG. 7



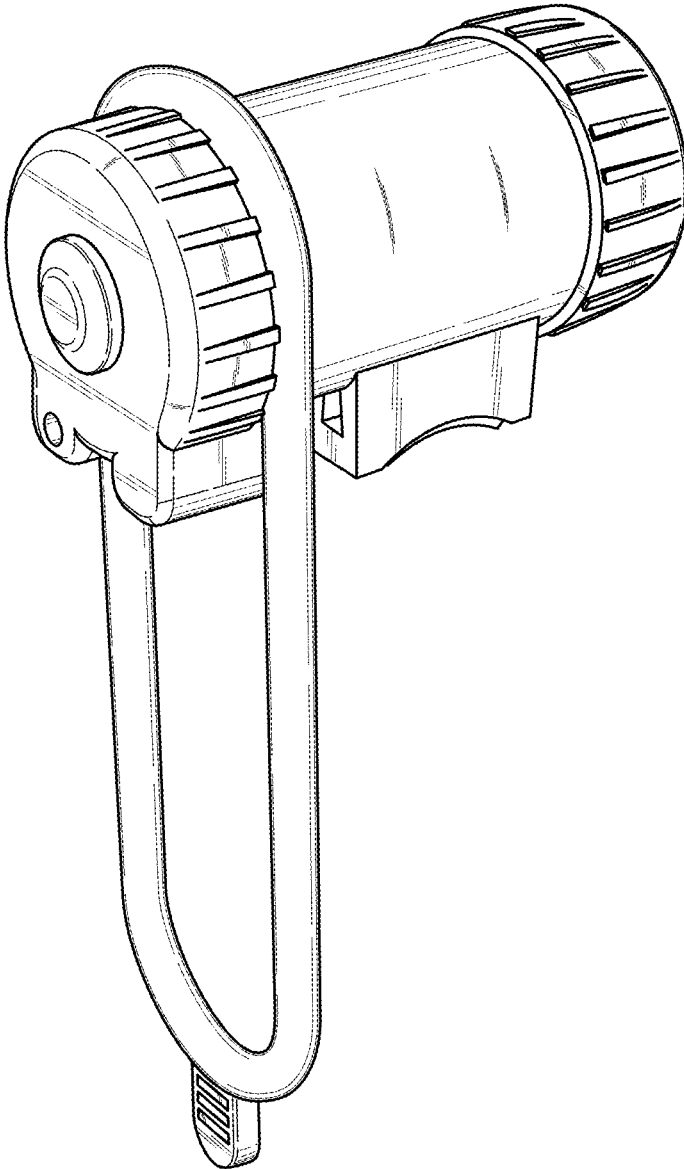

FIG. 8