

(19)
(12)

(KR)
(B1)

(51) 。 Int. Cl.7
H01J 29/02

(45)
(11)
(24)

2004 04 06
10-0426013
2004 03 24

(21) 10-2002-0024938

(65)

10-2003-0086773

(22) 2002 05 07

(43)

2003 11 12

(73) . ()
1 184

(72) 203 1402

(74)

:

(54)

(tube)

100% 120%

(purity)

3a

1
2a
2b

3a
3b
4

1

1 (1) (2) 가

(tube)
(3) (3) (4)

(3) (4) (5) (6) (7) (5)가 (8) (1)

(9) (6) R,G,B (CPM)(10)

가 (11) (12)가 (4) (11) (

12) (3) (11) (5) , CPM(10) R,G

,B (9) (6)

(11) (3) (9)가 (6)

(11) 가 가 2a 2

b (1) (6) (Lmin_a) (Lmax_a)

(Lmax_a/Lmin_a) 120% 200% 가 , (1) (6)

(Lmin_a, Lmax_a)가 14mm 30mm 가 가 2b

(Lmin_b) (Lmax_b) (1) (6)

(1) (6) (Lmax_b/Lmin_b) 110% 130% 가 ,

(Lmin_a) (Lmax_a) 가 16mm 27mm 가 .

(201) 가 (202) 가 (202)

가 (6) (1) 2 (201) (202)

가 >> (201) , 가 (201) (202)

가 가 가 가

가 (가) 가 가

가 가

		(purity)		(tube)		가		가 (shift)	
0%	120%	100%	120%	10mm	20mm	10mm	15mm	10mm	20mm
3a	3b	3a	3b	3a	3b	3a	3b	3a	3b
(Lmin_a')	(Lmin_b')	(Lmin_a')	(Lmin_b')	(Lmax_a')	(Lmax_b')	(Lmax_a')	(Lmax_b')	(Lmax_a')	(Lmax_b')
100%	120%	100%	120%	10mm	20mm	10mm	20mm	10mm	20mm
(1)	(6)	(1)	(6)	(1)	(6)	(1)	(6)	(1)	(6)
30mm	27mm	16mm	27mm	16mm	27mm	16mm	27mm	16mm	27mm
(301)	(301)	(301)	(301)	(301)	(301)	(301)	(301)	(301)	(301)
120%	200%	120%	200%	120%	200%	120%	200%	120%	200%
(1)	(6)	(1)	(6)	(1)	(6)	(1)	(6)	(1)	(6)
14m	14m	14m	14m	14m	14m	14m	14m	14m	14m
(3)	(3)	(3)	(3)	(3)	(3)	(3)	(3)	(3)	(3)
110%	130%	110%	130%	110%	130%	110%	130%	110%	130%
(301)	(301)	(301)	(301)	(301)	(301)	(301)	(301)	(301)	(301)

3

2

4 (1) (6) 100% 150%

4)가 가 가 (1) (6) (/)가 120% (/)

/) 100% 120% (6) ((

「 2」 (1) (6) (100% 120%) 10mm 15mm 10mm 18mm 10mm

(1) (6) (6) (1) (1) (scratch)

h)가 가 10mm 15mm 18mm (1)

「 3」 (1) (6) (100% 120%) 10mm 20mm 10mm 24mm

10mm (scratch)가 가 10mm 20mm (6) (1) (1) (1) 24mm

120%

100%

10mm 18mm 10mm 20mm, 10mm 15mm, 10mm 24mm

가 가 가

(57)

1.

가
가

()
「 / 「

「 100% 120%

2.

1

10mm 15mm

3.

1	,		10mm	18mm
1	4.	,	10mm	20mm
1	5.	,	10mm	24mm

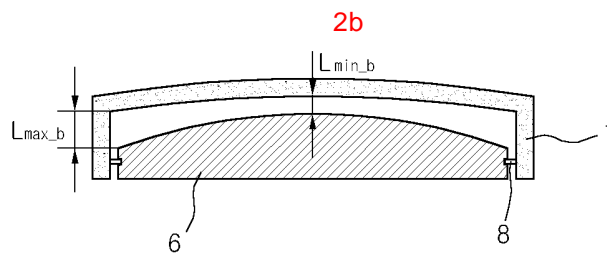
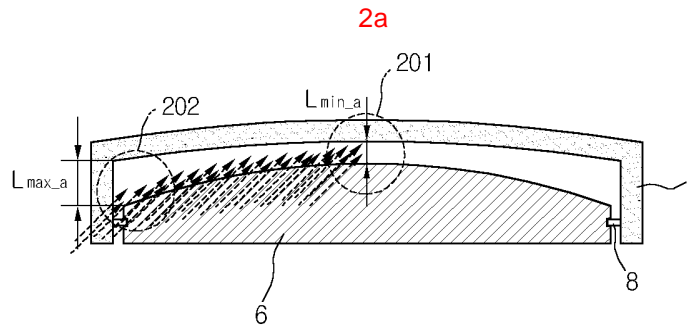
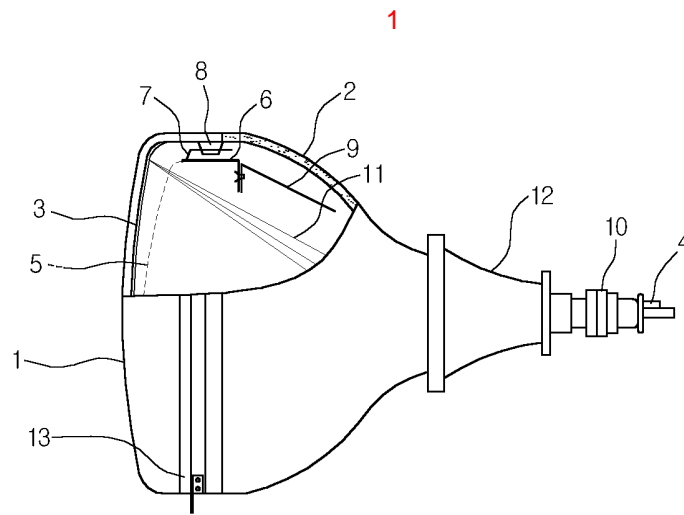

3a

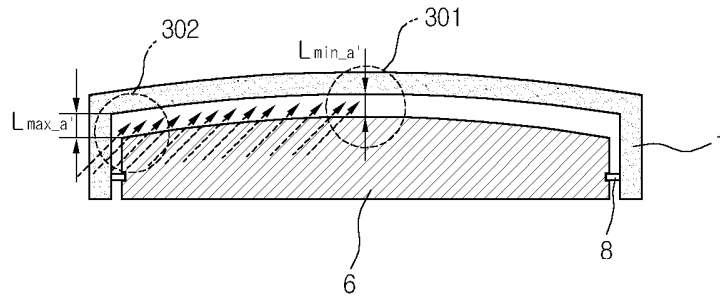

3b

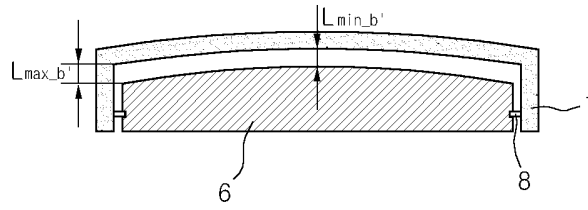

4

