

Aug. 10, 1965

E. R. KOPPEL

3,199,571

BURNER CASTING FOR INFRARED GAS BURNER

Filed Oct. 1, 1962

2 Sheets-Sheet 1

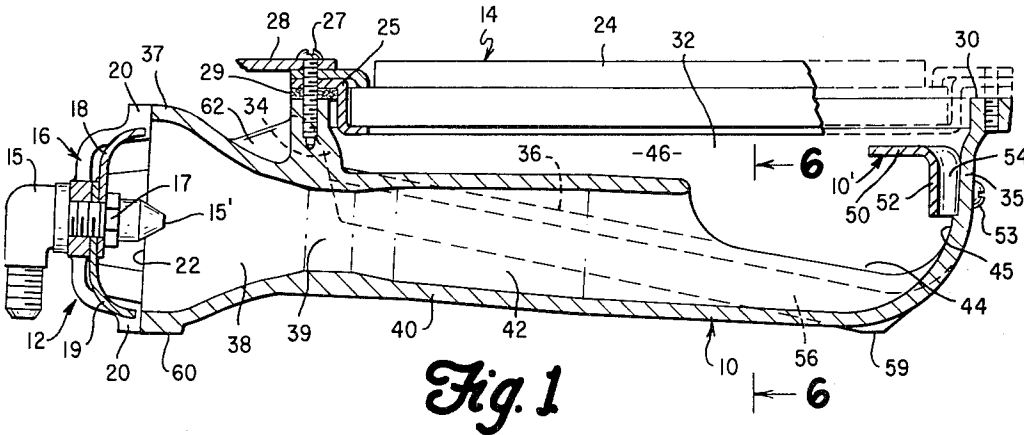

Fig. 1

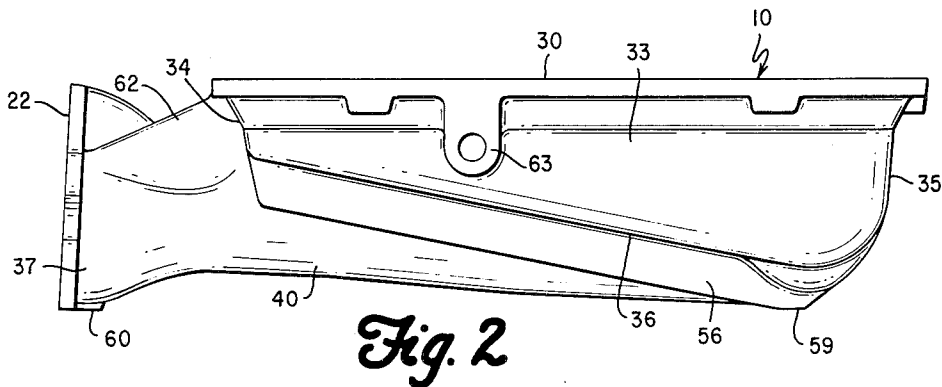

Fig. 2

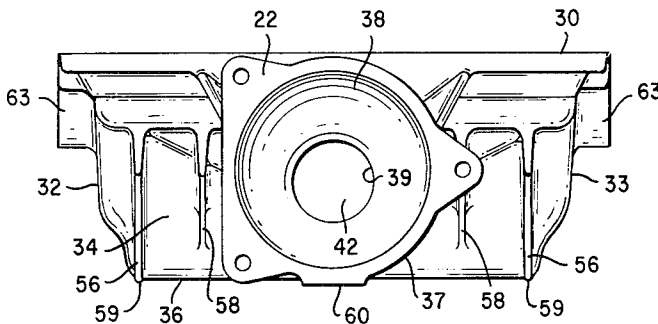

Fig. 3

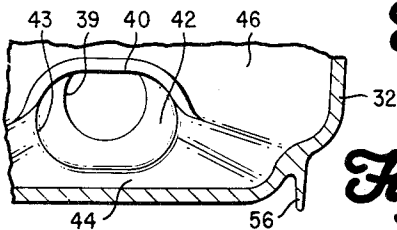

Fig. 6

INVENTOR.
ERNST RUDOLF KOPPEL

BY
Souther & Stoltenberg
ATTORNEYS

1

2

3,199,571
**BURNER CASTING FOR INFRARED GAS
 BURNER**

Ernst R. Koppel, Ferrysburg, Ohio, assignor, by mesne assignments, to General Precision, Inc., Tarrytown, N.Y., a corporation of Delaware
 Filed Oct. 1, 1962, Ser. No. 227,263
 1 Claim. (Cl. 158—114)

This invention relates to gas burners of the infra-red type and more particularly to a supporting device for a burner mat which comprises a main casting serving as a housing member for such burner mats and also as a means for supplying an explosive fuel mixture to the rear side of the mat, through which it passes to be burned on the outer face thereof.

The invention contemplates the provision of a cast metal supporting housing for a burner mat having an interior configuration which will improve the transmission and distribution of the combustible fuel mixture to the inner surface of a mat or like burner mat mounted on the casting.

The invention further contemplates the provision of a metal housing which is provided with baffling means to improve the distribution of the air-gas fuel mixture when the explosive fuel mixture is directed into the housing serving as a distribution chamber.

The invention includes a burner device having improved baffling means in the supporting housing to enhance the distribution of the combustible fuel which consists of a preformed sheet-metal member suitably mounted to the casting.

It is well known by those experienced in the art that heat from radiant heaters of the infra-red gas burner type is not produced by individual projecting flames as is characteristic of the common gas burner. The radiant heat of an infra-red burner is produced by the combustion of air-gas fuel within a plurality of closely spaced comparatively small passages formed in a burner mat which results in combustion without a visible flame across the entire surface of the mat and not a series of visible irregularly projecting flames. The overall result is a uniform glow having an incandescent appearance.

There are two requirements necessary in a burner casting to produce a so-called uniform radiant glow on the surface of the burner mats. First, it is essential that a proper mixture of air and gas is provided and that a thorough mixing of the fuel element takes place in the rear chamber of the burner formed between the mat and the supporting casting. If the air and gas is not thoroughly mixed in the mixing chamber before the fuel reaches the passages at the lower surface of the burner mat, a uniform combustion of the fuel will not take place and thus a uniform glow will not be produced on the upper or heated surface of the mat where the combustion is completed. A thorough air-gas mixture is the result of controlled turbulences in the air-fuel elements in the mixing chamber which is caused by the inner configuration of the casting.

The second requirement is that a uniform volume of air-fuel mixture is distributed to the lower surface of the burner mat to thereby provide a uniform pressure at all of the combustion passages in the burner mat. The proper distribution of the air-fuel mixture is also dependent on the inner configuration of the burner casting. Both of the aforementioned requirements have been a recurring problem in the infra-red burner industry. It is, therefore, a principal object of this invention to provide an improved burner casting for infra-red type gas burners which will produce a uniform radiant heat from burner mats mounted on the burner housing.

It is another object of this invention to provide a burner housing for infra-red gas burners which has an inner configuration designed to improve the mixing process of the air-fuel mixture supplied to a mixing chamber in the casting.

It is another object of the invention to provide a burner housing device for infra-red gas burners which will have a unique inner configuration and a cooperating baffling member to insure a uniform distribution of the air-fuel mixture to the bottom surface of a burner mat, the baffling member creating a reverse flow of the fuel mixture in a plane parallel with the bottom surface of the burner mat.

It is still another object of the invention to provide an improved burner casting or housing for infra-red gas burners that will have features inherent in its design which will simplify the manufacturing of the device both in casting and machining operations, thus reducing the manufacturing costs.

Other objects and advantages of this invention relating to the arrangement, operation and function of the related elements of the structure, to various details of construction, to combinations of parts and to economies of manufacture will be apparent to those skilled in the art upon consideration of the following description and appended claim, reference being had to the accompanying drawings forming a part of this specification wherein like reference characters designate corresponding parts in the several views.

Referring to the drawings:

FIG. 1 is a sectional elevation through an infra-red gas burner assembly with a portion of the assembly broken away;

FIG. 2 is a side elevation of a burner casting showing portions of the exterior configuration;

FIG. 3 is an end elevation showing the fuel inlet end of the burner casting;

FIG. 4 is a top plan view of the burner casting showing the interior of the casting;

FIG. 5 is a bottom plan view showing additional portions of the exterior configuration; and

FIG. 6 is a sectional elevation taken along the line 6—6 of FIG. 1.

In the drawings, particularly FIG. 1, an infra-red gas burner assembly is shown, partly in section, comprising a main cast metal support member 10 referred to hereinafter as a burner casting or supporting housing, a gas jet coupling and air regulating assembly 12, and a burner mat assembly 14, which are attached thereto as shown. The assembly 12 includes a gas fitting 15 which is secured to a mounting bracket 16 by a nipple 17, which also may secure a pair of cooperating segmental cup-shaped members 18 and 19 to the mounting bracket 16. The members 18 and 19 are rotatably adjustable to open or close a triangularly shaped opening (not shown) between the two members to control the flow of atmospheric air into the burner, the basic principle of which is well known in the art. The mounting bracket 16 is formed with a plurality of radial projections 20 having air passages therebetween, by which it is mounted to a surface 22 of the burner casting 10 with suitable bolts or the like, not shown. The assembly 12 forms no part of this invention and will not be described further in detail.

The burner mat assembly 14 includes a mat 24 formed of ceramic or the like material, or a metallic screen and a two-piece metal frame 25. Bolts 27 are used to secure the mat assembly 14 and a heat reflector 28 (only a portion of which is shown) to the burner casting. A suitable gasket 29 is provided between the frame 25 and a machined surface 30 of the casting 10 to seal a fuel distribution chamber formed in the burner housing. The burner mat and related elements also form no part of this

invention but are the subject of a separate application for U.S. Letters Patent Serial No. 184,978, and, therefore, will not be described further in the instant disclosure. Serial No. 184,978 was filed on April 4, 1962 and is now abandoned.

The important feature of this invention is the burner casting 10 and its related baffle member 10'. The housing or casting 10 is generally conventional in form, in that it is provided with side walls 32 and 33 (FIGS. 1 through 5), end walls 34 and 35, and the bottom wall 36. The unique features of the casting are the means provided to improve inspiration of the air with mixing and distributing of the gaseous fuel within the interior of the casting.

The housing or casting 10 is provided with a flaring air inlet 37 having a mouth 38 in which gas is injected by an injection nozzle 15' formed in the nipple 17. The injected gas flows into the venturi constriction 39 and draws atmospheric air into the mouth 38 through the controlled opening provided by the members 18 and 19. The air-gas fuel then flows through the restricted opening 39 into the flare of the venturi tube 40. The restricted opening 39 of the venturi provides the initial action for the mixing process of the air and gas by causing the streams of air and gas to be closely intermingled when passing through the opening 39.

The venturi tube 40 provides a mixing chamber 42 for the air-gas supply, and has a conical configuration which fans out at its opposite end 43 terminating into a triangular fan-shaped area 44 formed in the bottom wall 36 of the casting (FIGS. 1 and 4). As can be seen in FIG. 1, the venturi slopes slightly downwardly which permits a shallower burner body and a longer flare for the venturi within a standard length burner casting, thus providing better air inspiration and uniform flow and distribution. The air-gas mixture is, further, improved when the fuel leaves the venturi and enters the triangular outwardly and downwardly extending fan-shaped area 44 which distributes the flow of the fuel over the whole width of the burner plenum. Turbulence is promoted by the change in the direction of the flow when the fuel mixture reaches an inner curved surface 45 extending transversely of the casting parallel to the casting wall 35 which tends to reverse the direction of flow.

Both the fan-shaped area 44 of the casting and the wall surface 45 serve a dual purpose, in that they not only cause additional mixing of the air-gas fuel by creating turbulence, but they also change the direction of flow of the fuel to an upward direction, so that after their influence diminishes, the fuel flow assumes a flattened pattern against the underside of the burner mat. The bottom wall 36 of the casting slopes upwardly on an angle from the area 44, thus providing a sloping floor for the distribution chamber 46. As the fuel mixture flows up the slope of the bottom wall 36 to move into the forward end of the distribution chamber, the volume becomes progressively smaller to again increase the overall pressure with relation to the volume of flow of the fuel mixture. This arrangement creates a more uniform static pressure in the fuel mixture underneath the burner mat which is necessary to assure uniform distribution of the fuel.

The baffle 10', mentioned hereinbefore, is provided to further assist in diverting the flow of fuel to the opposite end of the casting and also to insure flattening the flow pattern of fuel against the entire bottom surface of the burner mat, including the area directly above a horizontal portion 50 of the baffle 10'. The baffle is provided with a central indented vertical portion 52 formed therein and is suitably mounted to the casting wall 35 with rivets, bolts 53 or the like. The indented portion 52 forms an opening 54 between the baffle 10' and the inner surface of the casting wall 35 which is generally in a vertical position. The opening 54 allows more than enough fuel to flow therethrough to reach the portion of the mat di-

rectly above portion 50 of the baffle member. Also, the fuel is caused to flow above and below the portion 50 of the baffle, which causes the flow to be flatter and more directional, thus quieting the turbulence in the fuel mixture as it enters the main distribution chamber to assure uniform distribution of the fuel.

The arrangement as described for mixing, directing, and distributing the explosive gaseous fuel mixture in the casting has been found to be an improvement over existing burner castings, in that separate and distinct provisions are provided within the casting for each of the steps mentioned that are known to be necessary requirements to realize peak efficiency from infra-red gas burners. The casting also has features on its exterior that do not affect the burner operation but are desirable for other reasons which will now be described.

The outer surface of the casting 10 is provided with cooling and strengthening means in the form of longitudinal fins 56 and 58. The fins are integral portions of the casting and provide a means for heat radiation from the casting which maintains the temperature in the distribution chamber at a lower figure to prevent back-firing. The existence of the fins also permits a thinner wall construction in the bottom of the casting since the strength required in this area is provided by the addition of the fins. The casting is designed, so that it can be supported in a horizontal position by resting on lower edges 59 of the fins 56 and on a lower portion 60 of the fuel inlet 37 on a plane surface. This has no effect on the operation of the burner since the burner can be used in any position, but is a desirable feature from a manufacturing standpoint. Horizontal positioning of the castings facilitates machining and assembling operations on the castings and also provides for easier storing. Strengthening webs 62 are provided at each side of the fuel inlet mouth 37 which are integral portions between the fuel inlet and the wall 34. This also permits thinner wall construction. The casting also has projecting bosses 63 provided on the side walls 32, 33 having threaded cavities therein to facilitate bolting the casting to either a floor standard, furnace frame, or the like.

It is to be understood that the above detailed description of the present invention is intended to disclose an embodiment thereof to those skilled in the art, but that the invention is not to be construed as limited in its application to the details of construction and arrangement of parts illustrated in the accompanying drawings since the invention is capable of being practiced and carried out in various ways without departing from the spirit of the invention. The language used in the specification relating to the operation and function of the elements of the invention is employed for purposes of description and not of limitation, and it is not intended to limit the scope of the following claim beyond the requirements of the prior art.

What is claimed:

In an infrared gas burner, a housing having an open box-like configuration including a bottom, a pair of side walls and front and back end walls, a venturi tube extending along the bottom of said housing, one end of said venturi tube defining a mouth adjacent to said front end wall for introducing fuel into said housing, a burner mat mounted over the open top of said housing, gas injecting means for injecting a mixture of gas and air into said mouth of the venturi tube, said venturi tube having a restriction intermediate the ends thereof and flaring outwardly from said restriction toward the other end of the venturi tube, which other end terminates in spaced relation to said back end wall, said bottom having a triangular fan-shaped depression therein extending the flare of the venturi tube to substantially the entire width of said back end wall to distribute the fuel over said back end wall, said venturi tube and housing being formed as a single casting with the portions of said bottom on either side of said venturi tube sloping upwardly from said fan-

shaped depression toward said front end wall whereby the volume of the housing becomes progressively smaller toward the front of said housing, and baffle plate means projecting forwardly from said back end wall along the under side of said burner mat, the juncture between said fan-shaped depression and the bottom of said back end wall being curved to smoothly deflect the fuel upwardly toward said baffle plate means, said baffle plate means extending over substantially the entire width of said back end wall to direct fuel flowing up said back end wall from said triangular depression back along the under side of said burner mat, said baffle plate means having an angle-shaped cross section with one leg being fixed to said back end wall and the other leg extending forwardly beneath and spaced from the burner mat, said one leg cooperating with said rear end wall to define a channel extending substantially the width of said baffle plate means for passing part of the fuel to the portion of the burner mat overlying said other leg.

References Cited by the Examiner

UNITED STATES PATENTS

529,003	11/94	Whittingham.	
678,624	7/01	McKallip	158-114
2,550,296	4/51	Raulston	158-114
2,870,830	1/59	Schwank	158-114
3,084,736	4/63	Mentel	158-114
3,152,873	10/64	Wright.	

FOREIGN PATENTS

500,724	2/51	Belgium.
616,491	3/61	Canada.

15 FREDERICK L. MATTESON, Jr., *Primary Examiner*.
 JAMES W. WESTHAVER, *Examiner*.