

W. B. FORD.
FLOAT ACTUATED VALVE.

(Application filed Jan. 15, 1900.)

(No Model.)

Fig. 1.

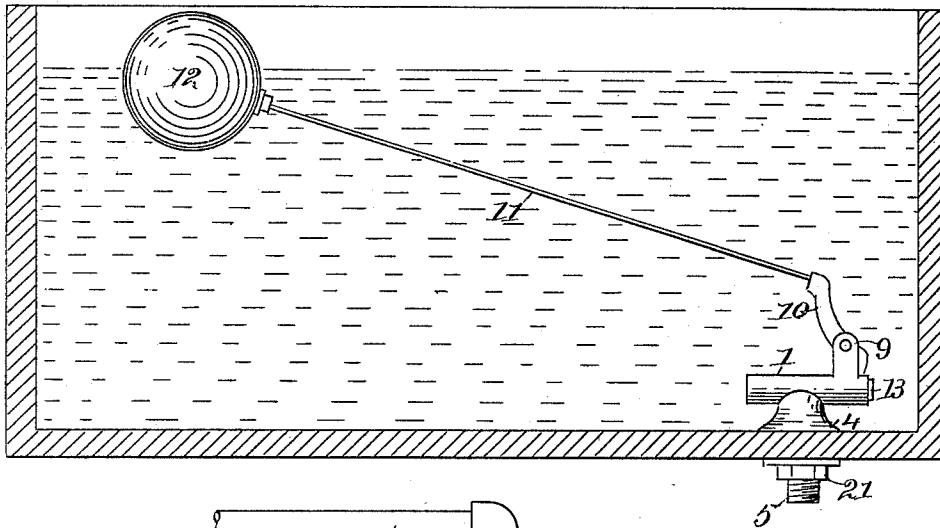

Fig. 2.

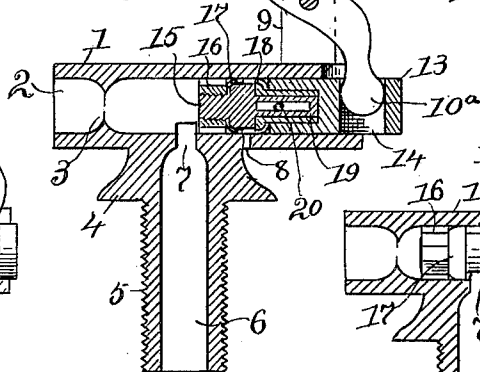

Fig. 4.

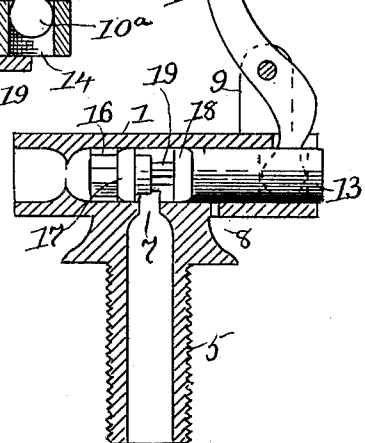

Fig. 3.

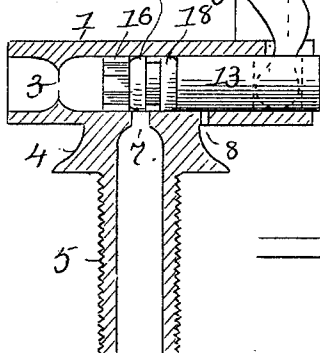
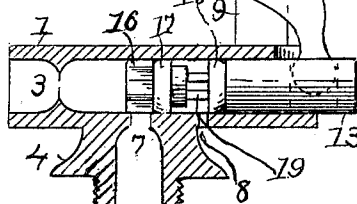

Fig. 5.



Attest,
Nora Graham
Sua Graham.

Inventor,
Wm. B. FORD,
by L. P. Graham
his attorney

UNITED STATES PATENT OFFICE.

WILLIAM B. FORD, OF DECATUR, ILLINOIS.

FLOAT-ACTUATED VALVE.

SPECIFICATION forming part of Letters Patent No. 649,635, dated May 15, 1900.

Application filed January 15, 1900. Serial No. 1,438. (No model.)

To all whom it may concern:

Be it known that I, WILLIAM B. FORD, of the city of Decatur, county of Macon, and State of Illinois, have invented a certain new and useful Ball-Cock, of which the following is a specification.

This invention provides a durable partly-automatic valve for closet-tanks and the like which is quick-acting and noiseless in closing and that has no seat to wear and be cut away by the action of the water. It is exemplified in the structure hereinafter set forth, and it is defined in the appended claims.

In the drawings forming part of this specification, Figure 1 is a section through a tank supplied with one of my valves. Fig. 2 is a section lengthwise through a valve constructed in accordance with my invention, the passage-way of the valve being shown open to admit water to the tank. Fig. 3 is a longitudinal section through the valve-body, showing the valve partly closed by the action of the float in the tank. Fig. 4 is a like section showing the valve forced entirely closed by the action of the water. Fig. 5 is a similar section showing the valve forced open. In the last-named figure the parts of the valve are supposed to be held separated by water which has not yet passed through the waste-hole.

The body of the valve is a hollow cylinder 1. A base 4 is ordinarily formed on a side of the body, and a threaded extension 5 of the base 4 is adapted to extend through the bottom of a tank and provide a connection for a supply-pipe. A passage-way 6 in the threaded lateral extension communicates with the interior of the valve-body through a narrow slit 7, which extends crosswise of the body.

The valve is of the piston type, and it stops the flow of water by moving past the inlet-slit 7. The valve-stem is in two parts, one of which has a limited amount of longitudinal motion with relation to the other, and this motion is utilized in closing the valve by permitting the inlet flow to pass behind the valve-cup when the valve is only partly closed and to complete the closing operation independent of the float or other outside influence.

In the drawings one part of the valve-stem is shown at 13 and the other part at 15. (See Fig. 2.) The part 15 has an extension 19,

which extends into a bore in part 13 and has a limited amount of independent motion lengthwise thereof. In this case the extension 19 is longitudinally slotted and is held connected with part 13 of the valve-stem by means of a pin 20, which extends through the slot; but I do not confine myself to this particular means of providing the limited independent longitudinal motion in part 15.

The part 15 of the valve-stem has a cup-valve 17, which is presented or cupped toward part 13, and part 13 has a valve 18, which is cupped in the opposite direction. The valves are separated some distance by a shoulder formed on part 15 of the valve-stem or by other means, and the part 15 has a guide nut or extension 16, which is in advance of valve 17, which conforms in general outline to the interior of the cylindrical valve-body 1 and which has peripheral passage-ways for water.

The part 13 of the valve-stem has a slot 14. (Shown in Fig. 2.) Lugs 9 rise from the valve-body, and a lever 10 is fulcrumed between the lugs and has a rounded end 10^a extended into the slot 14 in the valve-stem. A float-stem 11 is fastened in the upper end of the lever 10, and a float 12 is carried on the swinging end of the stem. The extension 5 of the base of the body is set through a hole in the bottom of the tank and held therein by a clamp-nut, as shown at 21 in Fig. 1, and the projecting threaded end provides a connection for a supply-pipe.

When the tank begins to fill, the valve is in the position shown in Fig. 2. As the water rises the float is carried up with it and the valves are shifted toward the closing-point until the rear edge of valve 17 passes the rear edge of slit 7, as shown in Fig. 3. At this juncture some water is still passing into the tank; but the instant water is admitted back of valve 17 such valve is noiselessly shot by the force of the water to the position shown in Fig. 4 and further passage of water to the tank is effectually stopped. In addition to this the pressure of the water tends to expand the cup-formed valves against the interior of the valve-body and effectively and automatically prevents leakage.

When the water is drawn from the tank, the float forces the valves to the position shown in Fig. 5, where they are temporarily

held widely separated by the water contained between them; but as soon as such inclosed water can pass through a waste-hole, as 8, the valve 17 is forced to the position shown in Fig. 2 by the pressure of the water accumulating in the tank, and by the time the tank is filled all is in readiness for a repetition of the operation already described.

To lessen the possibility of the valve 17 traveling prematurely in advance of the movement of the float-lever, I diminish the outlet 2 of the valve-body to a size smaller than the inlet 6 and 7, as shown at 3, which gives a slight back pressure on the automatic valve and insures its proper action.

The slit 7 is slightly wider than is the valve 17, and its sides are parallel. It is crossed at all points simultaneously, and there is no tendency to develop the peculiar noise incident to the closing of a gradually-decreasing opening even if the quick automatic action of the valve would give time for the production of the noise. The lateral extension of the slit permits a short closing movement of the valve, and this expedites the operation.

The valve is particularly applicable to closet-tanks; but I do not confine it to that or any other particular use.

I claim—

1. A valve comprising a body having a side inlet, a two-part piston-valve stem one part of which has a limited amount of longitudinal motion independent of the other and a valve on each part of the stem completely closing the body; the valve on the independently-movable part of the stem being narrower than the inlet-opening and having a path of motion back and forth across the same, and the body having a waste-hole opposite the space between the valves when the inlet is open.

2. A valve comprising a body having a slit-formed side inlet crosswise of the body, a two-part piston-valve stem one part of which has a limited amount of longitudinal motion independent of the other, and a valve on each part of the stem completely closing the body; the valve on the independently-movable part of the stem being narrower than the slit-formed opening and having a path of motion back and forth across the same, and the body having a waste-hole opposite the space between the valves when the inlet is open.

3. A valve comprising a body having a side inlet, a two-part valve-stem one part of which has a limited amount of longitudinal motion independent of the other, a valve on one part having a path of motion back and forth across the inlet and a valve on the other part having a path of motion toward and from the inlet, the valves being separated one from the other and the body having a waste-hole opposite the space between the valves when the inlet is open.

4. A valve comprising a body having a side inlet, a two-part valve-stem one part of which is controlled by a float and the other of which has a limited amount of independent longitudinal movement, a valve on the independently-movable part having a path of motion back and forth across the inlet, and a valve on the float-controlled part having a path of motion toward and from the inlet, the valves being separated one from the other and the body having a waste-hole opposite the space between the valves when the inlet is open.

In testimony whereof I sign my name in the presence of two subscribing witnesses.

W. B. FORD.

Witnesses:

PHILIP MUELLER,
C. O. FOUGET.