

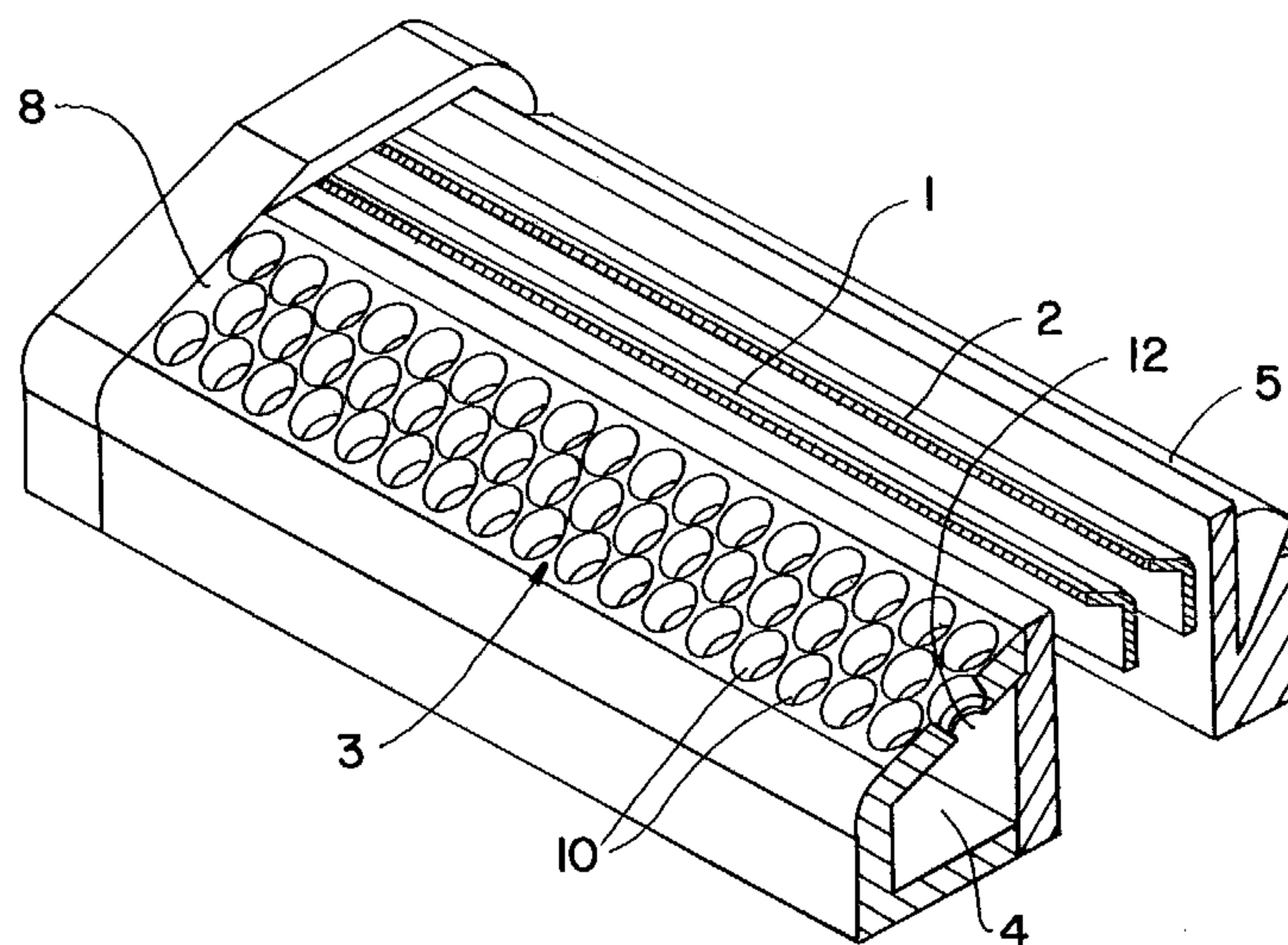

(11) (21) (C) **2,194,278**  
(86) 1995/07/11  
(87) 1996/02/01  
(45) 2000/02/29

(72) Oldroyd, Brian, GB  
(73) THE GILLETTE COMPANY, US  
(51) Int.Cl.<sup>6</sup> B26B 21/14  
(30) 1994/07/13 (9414092.8) GB  
(54) **RASOIRS DE SECURITE**  
(54) **SAFETY RAZORS**



(57) Une unité de rasoir de sécurité (Fig. 1) comprend au moins une lame allongée (1, 2), et un élément (3) venant au contact de la peau s'étend longitudinalement par rapport à la lame ou aux lames (1, 2), il définit une surface (9) destinée à venir en contact avec la peau durant le rasage. L'élément (3) venant au contact de la peau comporte une multitude de poches (10) contenant des portions individuelles de produit améliorant le rasage (Fig. 2). Chacune de ces poches (10) s'ouvre au niveau de la surface (9) venant en contact avec la peau. Les poches (10) sont réparties le long de la surface (9) et sur sa largeur, formant un motif recouvrant sensiblement toute la surface (9) venant en contact avec le peau.

(57) A safety razor blade unit (fig. 1) comprises at least one elongate blade (1, 2), and a skin engaging member (3) extends longitudinally of the blade(s) (1, 2) and defines a surface (9) exposed for contact with the skin during shaving. A multiplicity of pockets (10) are provided in the skin engaging member (3) for holding respective portions of a shaving enhancement product (fig. 2). Each of the pockets (10) opens at the skin contacting surface (9). The pockets (10) are distributed along the surface (9) and across the width thereof in an array spanning substantially the whole of the area of the skin contacting surface (9).



## INTERNATIONAL APPLICATION PUBLISHED UNDER THE PATENT COOPERATION TREATY (PCT)

(51) International Patent Classification <sup>5</sup> : B26B 21/14	A1	(11) International Publication Number: WO 96/02369 (43) International Publication Date: 1 February 1996 (01.02.96)
<p>(21) International Application Number: PCT/US95/08634</p> <p>(22) International Filing Date: 11 July 1995 (11.07.95)</p> <p>(30) Priority Data: 9414092.8 13 July 1994 (13.07.94) GB</p> <p>(71) Applicant (for all designated States except US): THE GILLETTE COMPANY [US/US]; Prudential Tower Building, Boston, MA 02199 (US).</p> <p>(72) Inventor; and (75) Inventor/Applicant (for US only): OLDROYD, Brian [GB/GB]; 39 Cambrian Way, Calcot, Reading, Berkshire RG3 7DD (GB).</p> <p>(74) Agents: GALLOWAY, Peter, D.; Ladas &amp; Parry, 26 West 61st Street, New York, NY 10023 (US) et al.</p>	<p>(81) Designated States: AM, AT, AU, BB, BG, BR, BY, CA, CH, CN, CZ, DE, DK, EE, ES, FI, GB, GE, HU, IS, JP, KE, KG, KP, KR, KZ, LK, LR, LT, LU, LV, MD, MG, MN, MW, MX, NO, NZ, PL, PT, RO, RU, SD, SE, SG, SI, SK, TJ, TM, TT, UA, UG, US, UZ, VN, European patent (AT, BE, CH, DE, DK, ES, FR, GB, GR, IE, IT, LU, MC, NL, PT, SE), OAPI patent (BF, BJ, CF, CG, CI, CM, GA, GN, ML, MR, NE, SN, TD, TG), ARIPO patent (KE, MW, SD, SZ, UG).</p> <p>Published With international search report.</p> <p style="text-align: center; font-size: 2em;">2194278</p>	

(54) Title: SAFETY RAZORS

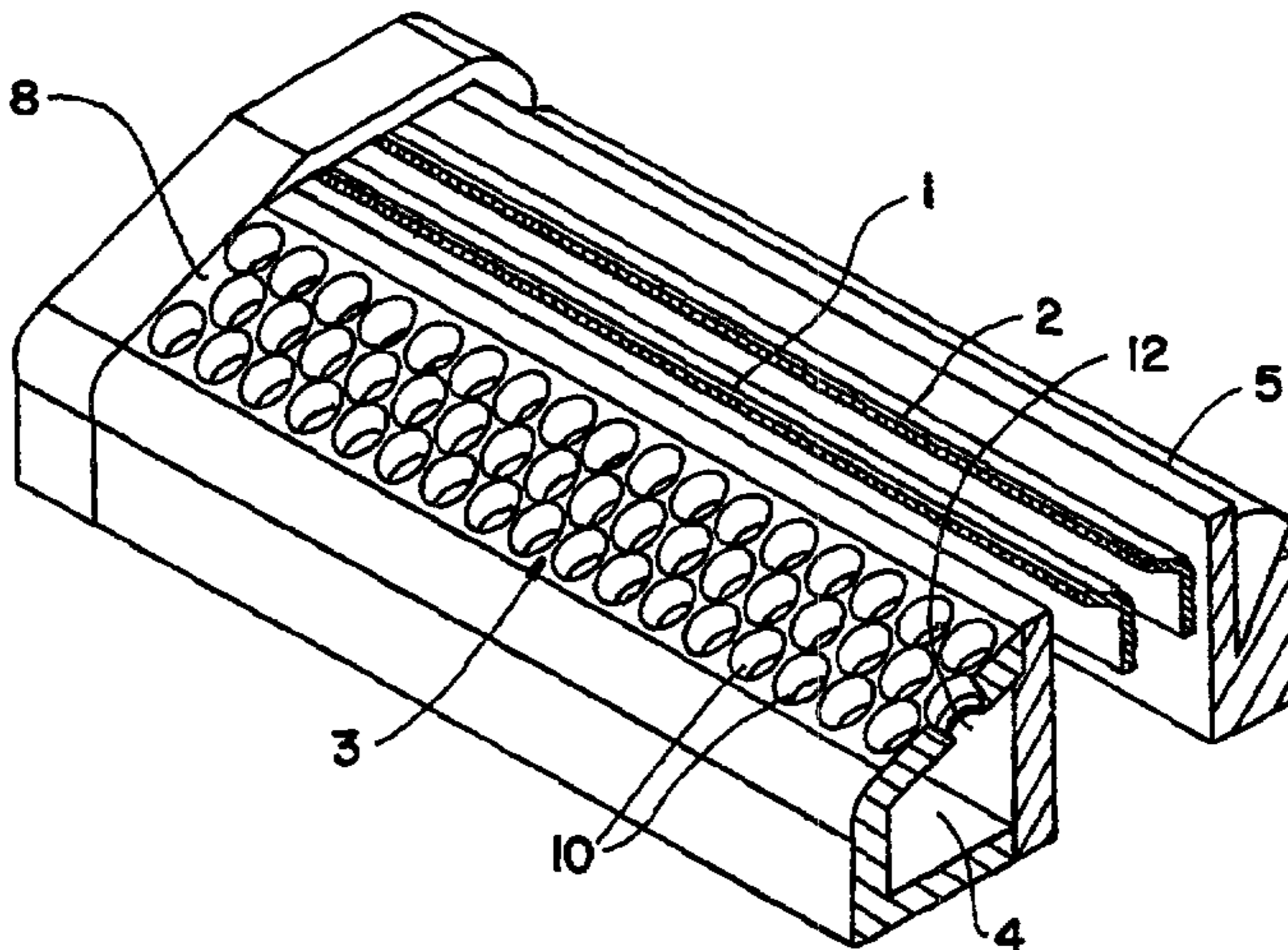

(57) Abstract

A safety razor blade unit (fig. 1) comprises at least one elongate blade (1, 2), and a skin engaging member (3) extends longitudinally of the blade(s) (1, 2) and defines a surface (9) exposed for contact with the skin during shaving. A multiplicity of pockets (10) are provided in the skin engaging member (3) for holding respective portions of a shaving enhancement product (fig. 2). Each of the pockets (10) opens at the skin contacting surface (9). The pockets (10) are distributed along the surface (9) and across the width thereof in an array spanning substantially the whole of the area of the skin contacting surface (9).

SAFETY RAZORS

This invention relates to shaving devices and concerns a safety razor blade unit having at least one blade with a cutting edge which is moved across the surface of the skin being shaved by means of a handle to which the blade unit is attached. The blade unit may be mounted detachably on the handle to enable the blade unit to be replaced by a fresh blade unit when blade sharpness has diminished to an unsatisfactory level, or it may be attached permanently to the handle with the intention that the entire razor be discarded when the blade or blades have become dulled. Razor blade units generally include a guard which defines a surface for contacting the skin in front of the blade(s) and a cap for contacting the skin behind the blade(s), the cap and guard serving important roles in establishing the so-called "shaving geometry", i.e. the parameters which determine the blade orientation and position relative to the skin during shaving. The present invention is especially concerned with the guard and/or cap of a razor blade unit.

As a preliminary step prior to shaving it is common to apply a shaving preparation to the skin, such as shaving soap or the like to

- 2 -

facilitate the shaving operation. One effect of the shaving preparation, for example, is to lubricate the skin to enable the razor to slide more easily over the skin. In some situations, however, the skin is not prepared as well as it might be. Furthermore, at the end of shaving most of the preparation will have been removed. Therefore, it can be advantageous to provide the razor with a means for delivering a shaving enhancement composition or medium during shaving. Thus, it is known to provide a blade unit with a strip of material from which a lubricant is very gradually leached out during shaving. The benefits of such a lubricating strip have been well proven, but the active materials which can be incorporated in them is limited, e.g. by the manufacturing process, and the rate at which the lubricant is discharged is so low that an effective preparation of the skin before shaving is still needed. There have also been proposed razors which include a chamber containing a liquid shaving preparation, and a system for discharging the liquid onto the operative parts of the razor by squeezing a sponge impregnated with the liquid by applying finger pressure. However, there still remains a need for a razor adapted to dispense a shaving aid product gradually throughout the useful life of the razor blade unit, without requiring special attention by the user, such as to refill a reservoir or to cause the product to be discharged when required.

According to the present invention there is provided a safety razor blade unit having at least one elongate blade, and a skin engaging member defining a surface exposed for contact with the skin during shaving, said

- 3 -

member including a multiplicity of pockets for holding respective portions of shaving enhancement product, said pockets being distributed longitudinally and laterally over the skin contacting surface and each being open at the surface.

A skin engaging member provided according to the invention may allow for the dispensing of materials which can not be included in prior art lubricating strips, e.g. because they can not withstand the manufacturing process. The shaving enhancement product may be a formulation, such as semi-solid gel, which has been designed to have the desired solubilizing properties, and is conveniently retained in the pockets due to the properties of the product. The product may be a viscous fluid, or a gel, and may be of a nature to be miscible with water, which is generally present during shaving, or to dissolve in water, to render the product more fluid for discharge from the pockets.

In order to provide adequate supply of shaving enhancement product to last the useful lifetime of the blade unit, the pockets can communicate at the inner ends with a reservoir chamber containing the shaving enhancement product to be dispensed via the pockets.

The pockets should be disposed in an array with sufficient density of packing to ensure satisfactory application of product during shaving. A width of surface between the adjacent pockets of 5% to 100% of the maximum transverse dimensions of the pockets should be adequate while retaining a sufficiently well defined skin contacting surface.

In a preferred construction the

pockets are cylindrical, i.e. have smoothly curved side walls, and conveniently the pockets are right circular cylindrical with their axes substantially perpendicular to the skin contacting surface. However, other shapes are also possible, such as hexagonal or elliptical in cross section. The depth of the pockets is less than the pocket diameter, e.g. approximately equal to the pocket radius, and the width of material between adjacent pockets is less than the pocket radius.

The pockets are preferably formed in a front wall of a chamber for holding a supply of a fluid shaving enhancement product, each of the pockets communicating with the chamber through a restricted opening to control flow of product into the pockets and hence release at the skin contacting surface.

The skin engaging member can be the guard of the blade unit or it can be another member, such as the cap.

A better understanding of the invention will be gained from the following detailed description of an embodiment, reference being made to the accompanying drawings, in which:

Figure 1 is a cut away perspective view of a razor blade unit according to the invention;

Figure 2 is a transverse cross section through the blade unit.

The safety razor blade unit shown in the drawings comprises a pair of blades 1, 2 mounted in tandem in a supporting frame, a guard 3 fastened to the frame and defining a hollow reservoir chamber 4, and a cap 5 e.g. in the form of a strip of lubricating material carried by the frame behind the blades.

The guard includes an upper wall 8 with an exposed surface 9 which is arranged to contact the skin during shaving. Within this wall is formed a multiplicity of pockets 10 positioned in a regular array extending over the length and width of the skin contacting surface. The pockets are disposed in a plurality of longitudinal rows, and in the shown example there are three rows with the pockets in adjacent rows

longitudinally off set to permit the pockets to be closely spaced. The pockets are of circular configuration and in the illustrated embodiment all have the same diameter.

5 Some of the pockets 10 are, and preferably each  
pocket 10 is, in communication with the reservoir chamber 4  
through a hole 12 shown to be of restricted area at the floor  
or inner end of the pocket. The through flow area of the hole  
is selected to allow shaving enhancement product contained in  
10 the chamber 4 to flow at a controlled rate into the pockets  
where the product collects and remains held e.g. under the  
surface tension properties of the fluid product, ready to be  
discharged during shaving. The restricted hole also serves to  
obstruct the passage of the shaving aid product from the  
pocket back into the reservoir chamber, so that the pockets  
15 remain charged with product. In practice the reservoir  
chamber will contain sufficient volume of shaving aid product  
to last the full useful lifetime of the blade unit, that is  
until the blades have become dulled.

20 The shaving aid product preferably has lubricating  
property, but it may have, either alternatively or in  
addition, other e.g. moisturizing properties considered  
beneficial

- 6 -

during shaving. It will have adequate fluidity to enable the product to pass from the reservoir chamber into the pockets, and adequate viscosity and surface tension characteristics to be held  
5 in the pockets without flowing freely out from the pocket openings, and to be dispensed gradually during shaving, e.g. upon being made more fluid by contact with water, when the guard surface slides over the skin during shaving.

10 It is not an essential feature that the pockets should be supplied with shaving enhancement product and it is within the ambit of the present invention for the pockets to be shaped and dimensioned to collect a shaving  
15 enhancement product applied to the skin during one time of shaving and to retain that product until the next time of shaving, e.g. to provide improved lubrication during the initial stages of the subsequent shave.

20 Modifications are of course possible without departing from the underlying inventive concept. For example, the member incorporating the pockets filled with shaving aid product could be made of a resilient material so that  
25 the member will flex slightly during shaving to encourage product to flow from the pockets. In addition to the benefits mentioned above the apertured member with the pockets may have a beneficial tactile influence upon the skin.



**THE EMBODIMENTS OF THE INVENTION IN WHICH AN EXCLUSIVE PROPERTY OR PRIVILEGE IS CLAIMED ARE DEFINED AS FOLLOWS:**

1. A safety razor blade unit comprising  
at least one elongate blade, and

5 a skin engaging member extending longitudinally of the or each blade and having an exterior skin contacting surface exposed for contact with a skin of a user during shaving, said member including

10 a multiplicity of pockets sized for holding respective portions of a non-rigid shaving enhancement product due to the fluid mechanical properties of the product, each of said pockets opening at the skin contacting surface and being defined by side wall portions depending inward from the skin contacting surface, and

15 said pockets being distributed along the surface and across the width thereof in a plurality of generally longitudinally extending rows forming an array spanning substantially the whole of the area of the skin contacting surface.

20 2. A safety razor blade unit comprising at least one elongate blade, and a skin engaging member extending longitudinally of the or each blade and having an exterior skin contacting surface exposed for contact with a skin of a user during shaving, said member including a multiplicity of  
25 pockets for holding respective portions of a non-rigid shaving enhancement product, each of said pockets opening at the skin contacting surface and being defined by side wall portions depending inward from the skin contacting surface, said pockets being distributed along the surface and across the  
30 width thereof in a plurality of generally longitudinally extending rows forming an array spanning substantially the whole area of the skin contacting surface, each pocket containing the non-rigid shaving enhancement product which is retained in the pocket due to the fluid mechanical properties  
35 of the product and which is discharged gradually therefrom during shaving.

3. A safety razor blade unit comprising  
at least one elongate blade,

5 a skin engaging member extending longitudinally of the or  
each blade and having an exterior skin contacting surface  
exposed for contact with a skin of a user during shaving, said  
member including a multiplicity of pockets sized for holding  
10 respective portions of a non-rigid shaving enhancement product  
due to the fluid mechanical properties of the product, each of  
said pockets opening at the skin contacting surface and being  
defined by side wall portions depending inward from the skin  
15 contacting surface, said pockets being distributed along the  
surface and across the width thereof in a plurality of  
generally longitudinally extending rows forming an array  
spanning substantially the whole of the area of the skin  
contacting surface, and

a reservoir chamber disposed underlying the skin  
contacting surface and containing the shaving enhancement  
product to be dispersed via the pockets, and

20 wherein some of the pockets have inner end portions  
bounding the depending side walls, said inner end portions  
defining flow restricting apertures communicating with the  
reservoir chamber, said flow restricting apertures metering a  
flow of the product from the reservoir to the skin contacting  
surface and constricting a backflow into the reservoir so the  
25 pockets remain charged with product.

4. A safety razor blade unit according to claim 3, wherein  
each pocket has said aperture communicating with the reservoir  
chamber.

5. A safety razor blade unit according to claim 3, wherein  
30 said skin engaging member partially confines said reservoir  
chamber.

6. A safety razor blade unit according to claim 1, wherein  
the pockets have smoothly curved side walls.

7. A safety razor blade unit according to claim 6, wherein the pockets are cylindrical with the axes thereof substantially perpendicular to the skin contacting surface.

5 8. A safety razor blade unit according to claim 6, wherein the pockets are right circular cylindrical.

9. A safety razor blade unit according to claim 7, wherein the pockets have a depth not greater than the pocket diameter.

10 10. A safety razor blade unit according to claim 3, wherein the pockets are positioned in a plurality of longitudinal rows.

11. A safety razor blade unit comprising at least one elongate blade, and

15 a skin engaging member extending longitudinally of the or each blade, said member having an exterior surface exposed for contact with a skin of a user during shaving, said member including a multiplicity of pockets sized for holding  
20 respective portions of a non-rigid shaving enhancement product due to the fluid mechanical properties of the product, each of said pockets opening at the skin contacting surface and being defined by side wall portions depending inward from the skin  
25 contacting surface, said pockets being distributed along the surface and across the width thereof in an array spanning substantially the whole of the area of the skin contacting surface,

wherein the pockets are positioned in a plurality of longitudinal rows, and the pockets of adjacent rows are longitudinally offset.

30 12. A safety razor blade unit comprising at least one elongate blade, and a skin engaging member extending longitudinally of the or each blade, said member having an exterior surface exposed for contact with a skin of a user during shaving, said member including a multiplicity of

pockets for holding respective portions of a shaving enhancement product, each of said pockets opening at the skin contacting surface and being defined by side wall portions depending inward from the skin contacting surface, said  
5 pockets being distributed along the surface and across the width thereof in an array spanning substantially the whole area of the skin contacting surface, each pocket containing a shaving enhancement product which is retained in the pocket due to the fluid mechanical properties of the product and  
10 which is discharged gradually therefrom during shaving, and wherein the pockets are positioned in a plurality of longitudinal rows, wherein the pockets of adjacent rows are longitudinally offset.

13. A safety razor blade unit comprising  
15 at least one elongate blade,  
a skin engaging member extending longitudinally of the or each blade and having an exterior surface exposed for contact with a skin of a user during shaving, said member including a multiplicity of pockets sized for holding respective portions  
20 of a non-rigid shaving enhancement product due to the fluid mechanical properties of the product, each of said pockets opening at the skin contacting surface and being defined by side wall portions depending inward from the skin contacting surface, said pockets being distributed along the surface and  
25 across the width thereof in an array spanning substantially the whole of the area of the skin contacting surface, and a reservoir chamber disposed underlying the skin contacting surface and containing the shaving enhancement product to be dispersed via the pockets,  
30 wherein some of the pockets have inner end portions bounding the depending side walls, said inner end portions defining flow restricting apertures communicating with the reservoir chamber, said flow restricting apertures metering a flow of the product from the reservoir to the skin contacting  
35 surface and constricting a backflow into the reservoir so the pockets remain charged with product, and

wherein the pockets are positioned in a plurality of longitudinal rows, wherein the pockets of adjacent rows are longitudinally offset.

5 14. A safety razor blade unit according to claim 1, wherein the pockets have depth at least about 50% of the maximum transverse dimension of the pockets.

15. A safety razor blade unit according to claim 14, wherein the pockets have depth not greater than the maximum transverse dimension of the pockets.

10 16. A safety razor blade unit according to claim 1, wherein the skin engaging member comprises a resilient material capable of flexing during shaving and exerting traction force on the skin surface being shaved.

15 17. A safety razor blade unit according to claim 1, wherein a width of surface between adjacent pockets is less than 50% of the maximum transverse dimension of the pockets.

18. A safety razor blade unit according to claim 1, wherein there are at least three longitudinally extending rows of pockets.

20 19. A safety razor blade unit according to claim 1, wherein the skin engaging member occupies a position of a guard surface in advance of the at least one blade.

25 20. A safety razor blade unit according to claim 1, wherein the skin engaging member occupies a position of a cap surface behind the at least one blade.

21. A safety razor blade unit according to claim 1, wherein the pockets are further defined by floor portions formed transverse to the depending side walls.

22. A safety razor blade unit according to claim 2, wherein the pockets are further defined by floor portions formed transverse to the depending side walls.

23. A safety razor blade unit according to claim 21 or 22 further comprising

5 a reservoir chamber receiving non-rigid shaving enhancement product, and

10 wherein the pocket floor portions define flow restricting apertures in communication with the reservoir, said flow restricting apertures metering a flow of the product from the reservoir to the skin contacting surface and constricting a backflow into the reservoir so the pockets remain charged with product.

24. A safety razor blade unit according to claim 2, wherein 15 the pockets have depth at least about 50% of the maximum transverse dimension of the pockets.

25. A safety razor blade unit according to claim 24, wherein the pockets have depth not greater than the maximum transverse dimension of the pockets.

20 26. A safety razor blade unit according to claim 2, wherein the skin engaging member comprises a resilient material capable of flexing during shaving and exerting traction force on the skin surface being shaved.

25 27. A safety razor blade unit according to claim 2, wherein a width of surface between adjacent pockets is less than 50% of the maximum transverse dimension of the pockets.

28. A safety razor blade unit according to claim 2, wherein there are at least three longitudinally extending rows of pockets.

30 29. A safety razor blade unit according to claim 2, wherein

the skin engaging member occupies a position of a guard surface in advance of the at least one blade.

5 30. A safety razor blade unit according to claim 2, wherein the skin engaging member occupies a position of a cap surface behind the at least one blade.

31. A safety razor blade unit according to claim 3, wherein the pockets have depth at least about 50% of the maximum transverse dimension of the pockets.

10 32. A safety razor blade unit according to claim 31, wherein the pockets have depth not greater than the maximum transverse dimension of the pockets.

15 33. A safety razor blade unit according to claim 3, wherein the skin engaging member comprises a resilient material capable of flexing during shaving and exerting traction force on the skin surface being shaved.

34. A safety razor blade unit according to claim 3, wherein a width of surface between adjacent pockets is less than 50% of the maximum transverse dimension of the pockets.

20 35. A safety razor blade unit according to claim 10, wherein there are at least three longitudinally extending rows of pockets.

36. A safety razor blade unit according to claim 3, wherein the skin engaging member occupies a position of a guard surface in advance of the at least one blade.

25 37. A safety razor blade unit according to claim 3, wherein the skin engaging member occupies a position of a cap surface behind the at least one blade.

38. A safety razor blade unit according to claim 1, 2 or 3,

wherein the at least one elongate blade comprises a linear edged blade member.

5 39. A safety razor blade unit according to claim 1 or 11, wherein the pockets of the array are spaced from adjacent pockets by wall segments having a width of 5% to 100% of the maximum transverse dimension of the pockets.

40. A safety razor blade unit according to claim 19, 29, or 36, further comprising a skin engaging member occupying a position of a cap surface behind the at least one blade.

10 41. A safety razor blade unit according to claim 11, 12 or 13, wherein neighboring rows are offset relative one another in the longitudinal direction by an amount less than a maximum transverse dimension of the pockets,

15 whereby an overlap, as viewed projected in a direction transverse to the longitudinal extent of the rows, results between neighboring pockets of adjacent rows.



1 / 2

FIG. 1

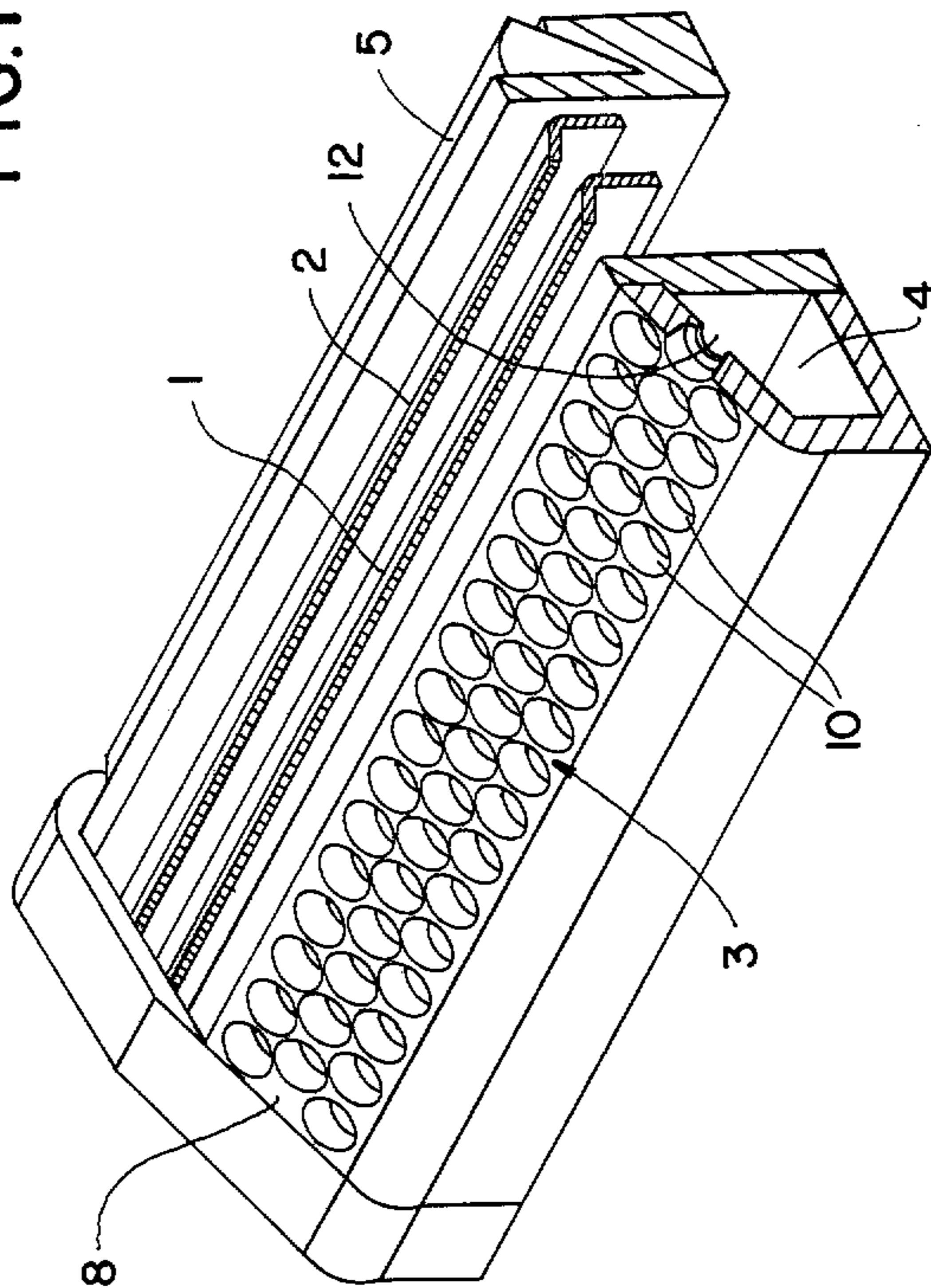

FIG. 2

