

[72] Inventor **Lucas H. Moe, Jr.**  
 Andover, Conn.  
 [21] Appl. No. **858,264**  
 [22] Filed **Sept. 16, 1969**  
 [45] Patented **Aug. 31, 1971**  
 [73] Assignee **United Aircraft Corporation**  
 East Hartford, Conn.

[56] **References Cited**

| UNITED STATES PATENTS |         |               |           |
|-----------------------|---------|---------------|-----------|
| 2,555,037             | 5/1951  | Jensen.....   | 128/417   |
| 3,151,619             | 10/1964 | Sullivan..... | 128/418 X |
| 3,163,166             | 12/1964 | Brant.....    | 128/405   |

*Primary Examiner*—Richard A. Gaudet  
*Assistant Examiner*—J. G. McGowan  
*Attorney*—Melvin Pearson Williams

[54] **PASTE DISPENSING BODY ELECTRODE**  
 3 Claims, 6 Drawing Figs.  
 [52] U.S. Cl. .... 128/2.06,  
 128/172.1, 128/417  
 [51] Int. Cl. .... A61b 5/04  
 [50] Field of Search ..... 222/386,  
 390; 128/172.1, 404, 405, 414, 417, 418, 218 D,  
 218 DA, 2.06, DIG. 4

**ABSTRACT:** A male electrode assembly fashioned with a body contacting adhesive coated web for attachment to a body includes a pair of relatively movable parts defining a reservoir for a conductive paste or jelly which is dispensed at the body-contacting side of the electrode in response to relative movement of the parts. Specific embodiments include a push plunger, with or without ribs, a threaded plunger, a bayonet locking plunger, and a simple female structure. Membranes protect the paste against effects of atmosphere, when required.

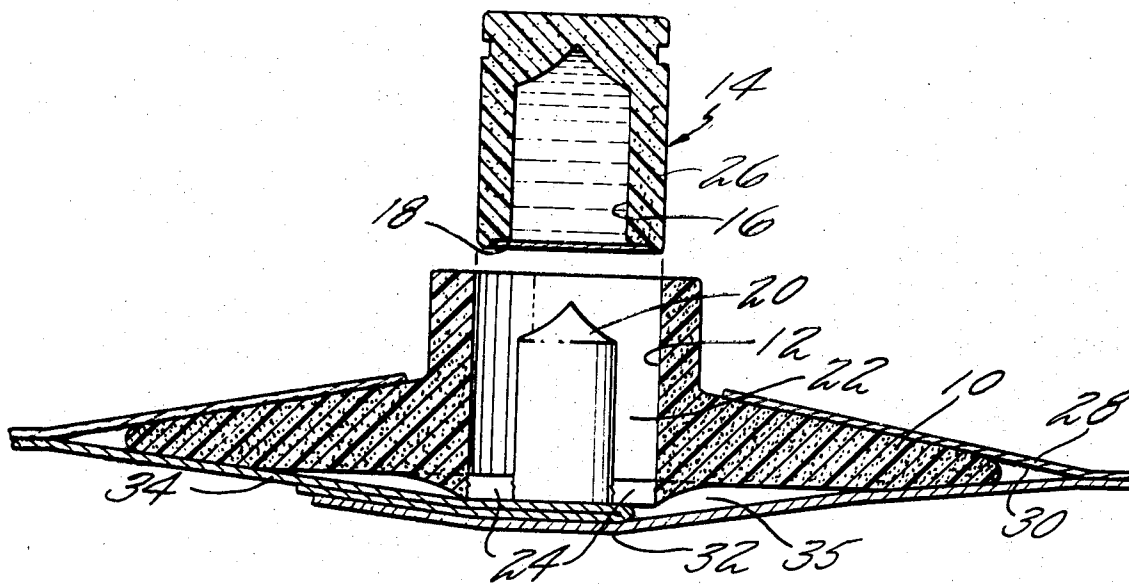

FIG. 1

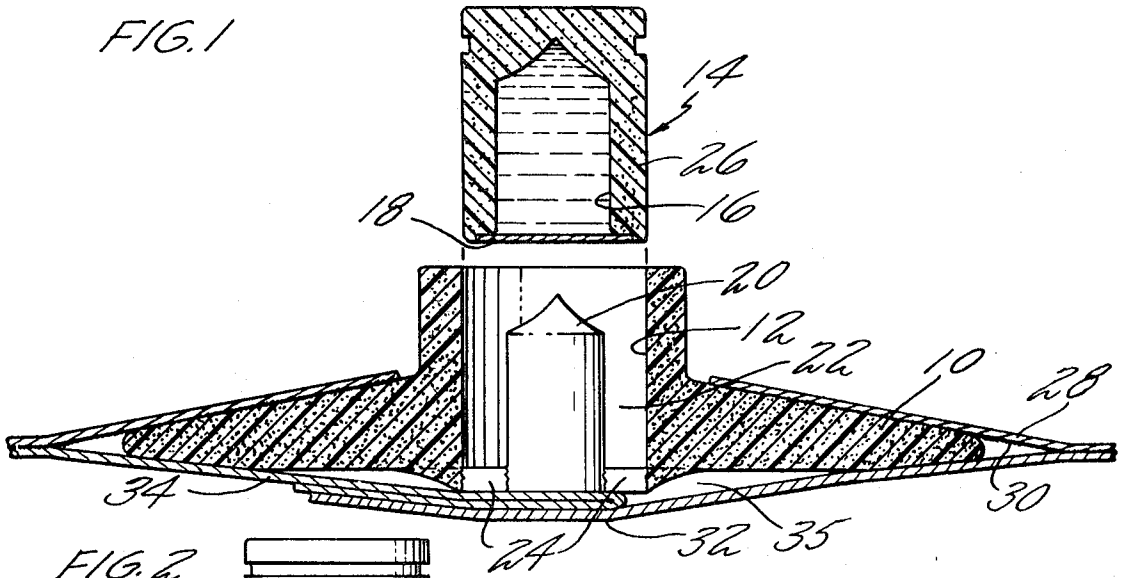

FIG. 2

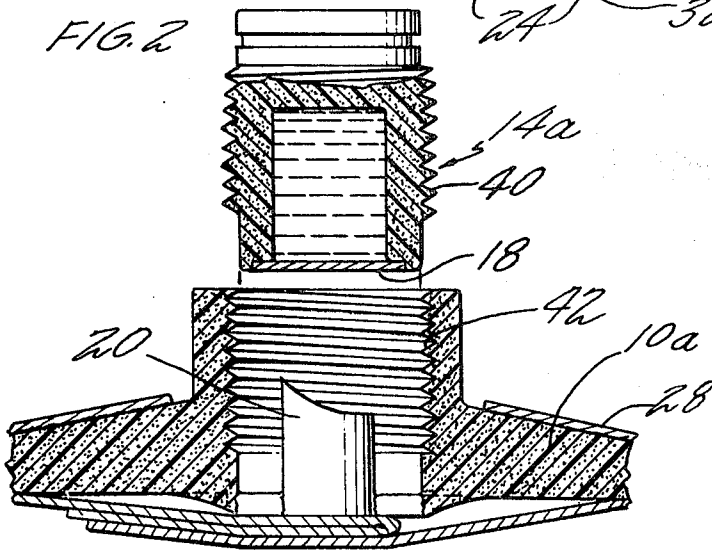

FIG. 4

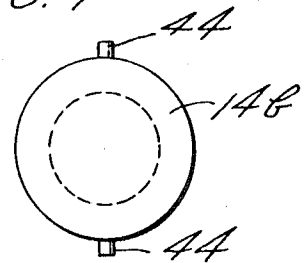
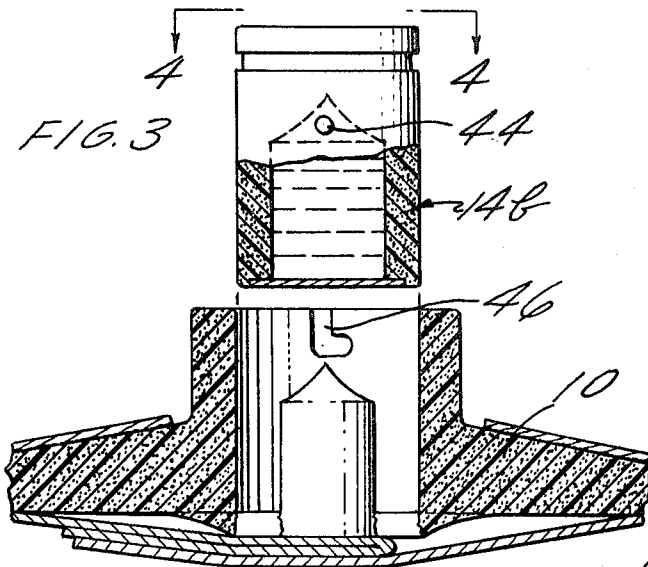

FIG. 3



INVENTOR  
LUCAS H. MOE, JR.  
Melvin Pearson Williams  
BY ATTORNEY

FIG. 5

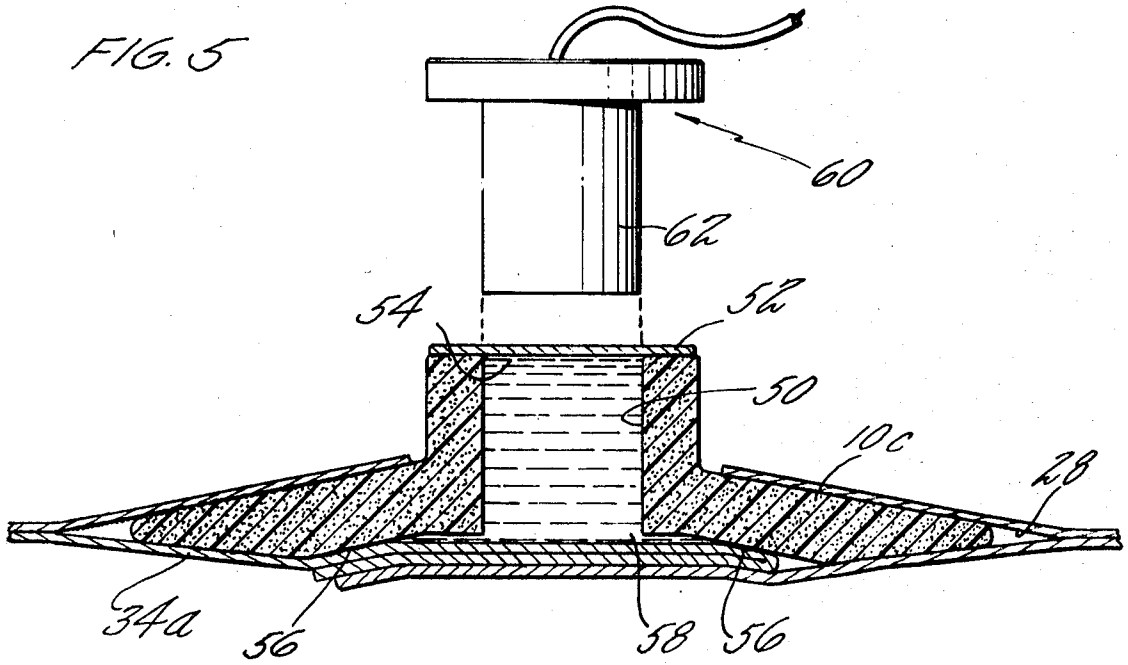
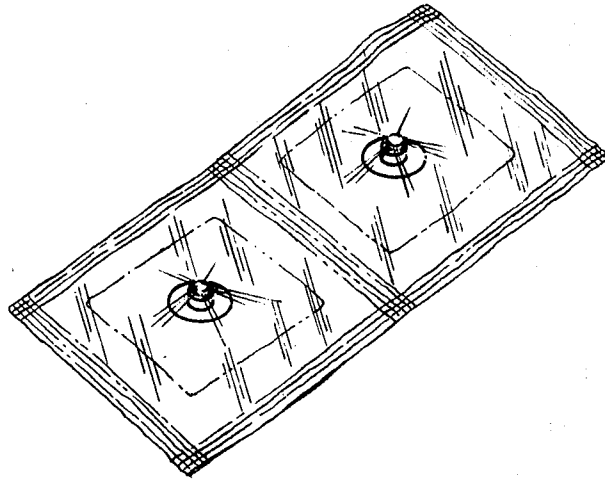

FIG. 6



## PASTE DISPENSING BODY ELECTRODE

### BACKGROUND OF THE INVENTION

#### 1. Field of Invention

This invention relates to body electrodes, and more particularly to a body electrode having conductive fluid dispensing capability.

#### 2. Description of the Prior Art

In the electromedical arts, the usage of body contacting electrodes, particularly for generating electrocardiograms, is well known. The basic structure of such devices includes a male or female electrode adapted to be secured to the skin of a patient by adhesive tape or the like integrally formed therewith. The electrode may include a conductive mesh to enhance electrical contact with the skin. In addition, conduction is improved by the application of a conductive fluid, such as a paste or jelly, to the skin at the area where the electrode is to make contact, prior to the securing of the electrode to the skin. This art is illustrated in Berman U.S. Pat. No. 3,085,577.

The application of a conductive paste or jelly to the skin must be carefully performed so as not to provide a slippery, nonadherable surface in the area where the adhesive or the like is to be firmly secured to the skin. Preferentially, a small area, exactly coextensive with the conducting portion of the electrode, should be provided with a suitable coating of conductive paste, the surrounding skin being left perfectly dry, coextensively with the area to which the adhesive material is to be secured. In this fashion, not only is the electrode mechanically fastened to the skin, but the tight adhesion of the adhesive material seals off the portion of skin to which contact is to be made, thus to avoid drying out of the conductive paste. The application of such electrodes has found some disfavor due to the difficulty of applying just the right amount of paste while insuring sufficiently good adhesion of the electrode to the skin to permit physical exercise of the wearer without loosening of the electrode.

### SUMMARY OF INVENTION

The object of the present invention is to provide an improved method and means for the application of a body electrode with an electric conduction enhancing paste.

According to the present invention, a multi part electrode includes a reservoir for receiving an electrically conductive paste or jelly, relative movements between the parts of the electrode causing the paste or jelly to be dispensed at the area of said electrode with which electrical contact is to be made to the skin of the wearer. In further accord with the present invention a one-piece female electrode has paste forced out of a void therein by insertion of a matching male connector.

The present invention permits a simple, substantially single step application of a body electrode with an electrically conductive fluid. Application to a wearer is achieved in a simple fashion requiring only the opening of a package, removing peel off layers, application of the adhesive portion of the electrode to the skin, followed by a simple motion causing relative movement between two parts of the electrode, or of the electrode and a matching connector, to dispense the electrically conductive paste or jelly in the area where electrical contact is to be made between the electrode and the skin. This area is sealed on dry skin by the integral adhesive, whereby application of the fluid will not impair the adherence of the electrode to the skin.

Other objects, features and advantages of the present invention will become more apparent in the light of the following detailed description of preferred embodiments thereof, as illustrated in the accompanying drawing.

### BRIEF DESCRIPTION OF THE DRAWING

FIG. 1 is a sectioned, exploded, side elevation of a plunger embodiment of the invention;

FIG. 2 is a sectioned, exploded, side elevation of a threaded embodiment of the present invention;

FIG. 3 is a sectioned, exploded, side elevation of a bayonet embodiment of the present invention;

FIG. 4 is a section taken on the line 4—4 of FIG. 3;

FIG. 5 is a sectioned, exploded, female embodiment of the present invention; and

FIG. 6 is a perspective view of exemplary packaging of electrodes in accordance with the present invention.

### DESCRIPTION OF THE PREFERRED EMBODIMENT

Referring now to FIG. 1, a paste dispensing electrode in accordance with the present invention comprises a main portion 10 which may be fabricated of metal or a conductive plastic, such as carbon impregnated nylon or Teflon of the type marketed under the designation LF-219 by the Polimer Corp. Reading, Pa. Otherwise, it may comprise a sintered porous plastic impregnated with conductive paste or liquid. The main portion 10 has a central opening 12 therein within which is disposed a male connector portion 14 which is movable with respect to the main portion 10. The connector 14 is provided with a chamber 16 adapted to store a conductive paste or jelly, of the type of saline paste known in the art to enhance conductivity between body electrodes and the skin. The conductive paste is sealed within the connector portion 14 by a membrane 18 which is relatively thin and easily pierceable by a punch anvil section 20 which may be designed in any number of ways to cause piercing of the membrane 18 prior to the application of substantial pressure to the conductive paste or jelly within the chamber 16. Surrounding the punch anvil section 20 is a cylindrical well 22 which accommodates a cylindrical wall 26 that forms the chamber 16, and which opens into a plurality of channels 24 which allow free passage of the conductive paste from the chamber 16 into contact with the skin as a result of pressure caused by forcing the male connector portion 14 downwardly to its fully seated position within the main structure 10. The electrode of FIG. 1 is provided with a thin webbing 28 having an adhesive layer 30 thereon, which may comprise well-known adhesive bandage material. A pair of peel off papers 32, 34 are used to protect the adhesive during shipment and storage.

Application of the embodiment of the present invention illustrated in FIG. 1 simply requires the removal of the peel off papers 32, 34 and sealing the electrode by means of the adhesive to a relatively clean dry area of the skin. When the adhesive backed webbing 28 is fully seated on the skin, a female electrode of the type illustrated in the aforementioned Berman patent may be applied to the male connector portion 14, forcing it downwardly so that the punch anvil 20 pierces the membrane 18, and continued downward motion causes the anvil 20 to displace the conductive paste from the chamber 16 and through the cylindrical void 22 and the channels 24 so that the paste then makes contact between the skin and the main portion 10, all within the sealed area 35 provided by the adhesive tape or webbing 28.

It is obvious that this operation is far simpler than that required in the prior art wherein the technician, nurse or patient applying the electrode has to gauge the amount of paste to be used, and properly center the electrode over the paste so that the paste does not interfere with the adherence of the adhesive webbing. Further, tubes or jars of paste and application paddles need not be maintained in inventory.

There are a large number of variations which may be made in the present invention, only a few of which are shown herein for exemplary purposes. For instance, in the embodiment of FIG. 1, either the male connector portion 14 or the hole 12 may be provided with vertical slots and the dimensions so chosen that, as the connector portion 14 is pressed into the main portion 10, the splines between the slots are deformed slightly thus causing an interference fit which will cause a good connection between the two pieces, both mechanically and electrically.

Another variation is illustrated in FIG. 2. Therein, matching threads 40, 42 are provided in the connector portion 14a and the main portion 10a, and the connector portion is rotated and

threaded inwardly prior to the application of the female connector. This has the advantage of guaranteeing relative motion between the two parts, with little or no pressure, but has the disadvantage of requiring the technician to achieve a firm grip on the connector portion 14 so as to be able to thread it inwardly.

Another variation is illustrated in FIGS. 3 and 4. Therein, the only distinction between the embodiment of FIG. 1 is that the connector portion 14b is provided with one or more bayonets 44 and the main portion 10 is provided with an L-shaped groove 46 to receive each bayonet, whereby the male portion 14b may be locked in place after being pushed into the paste extracting position.

A further embodiment of the present invention is illustrated in FIG. 5. Therein, the main portion 10c is provided with a simple central void 50 which is adapted to receive the conductive paste. An adhesive peel off membrane 52 is provided to seal the outward end 54 of the void 50, and the peel off piece 34a is provided with an adhesive portion 56 to seal the inner end 58 of the void 50. Application of the embodiment of FIG. 5 requires the removal of all three peel off layers 52, 32 and 34a, tightly adhering the adhesive layer 28 to the skin, and inserting a male connector 60, a plug portion 62 of which displaces the conductive paste through the inner end 58 of the void 50 into contact with the skin.

It should be noted that each of the embodiments has provided for sealing of the conductive paste so as to avoid thickening or hardening of it as a result of exposure to the atmosphere during shipment and storage prior to use. The invention is, however, usable in a simpler form without the various paste protective membranes in the case where the paste is constituted to the inert to atmosphere or to create a thin film by exposure to atmosphere, which film protects the remainder of the paste from alteration as a result of atmospheric exposure. Similarly, the affects of atmosphere on thickening or hardening of the conductive paste are mitigated by hermetic packaging, as illustrated briefly in FIG. 6. In some cases, it is possible that the hermetic packaging is all that is required, application of a very weak vacuum as the package is sealed being sufficient to remove excess atmosphere so that there will be no undue effect on the conductive paste. In such a case, the use of membranes as illustrated in FIGS. 1-5 herein may be eliminated.

In the foregoing embodiments, a conductive fluid, which may comprise a paste or jelly as is known in the art, is contained within a body electrode, and simple motion, required to connect the electrode to an external system through a matching electrode, or a plunging action, or rotation, is all that is required in order to dispense the conducting fluid to a skin-contacting area of the surface of said electrode. It should be understood that the embodiments of FIGS. 1-4 may be implemented with female connectors at the top thereof for matching with an external male connector. Similarly, the peel off membrane of the embodiment of FIG. 5 may be utilized if desired in the embodiments of FIGS. 1-4, or variations therein. The significant factor is that either a protective membrane must be peeled off prior to application of the electrode

to the skin, or the membrane should be pierced by the relative motion of two parts prior to application of significant pressure to the fluid so that the fluid will neither tend to resist the relative motion nor to flow outwardly, away from the skin-contacting surface of the body electrode.

Although the invention has been shown and described with respect to preferred embodiments thereof, it should be understood by those skilled in the art that the foregoing and other changes and omissions in the form and detail thereof may be made therein without departing from the spirit and scope of the invention.

Having thus described typical embodiments of my invention, that which I claim as new and desire to secure by Letters Patent of the United States is:

1. A multi part skin contacting body electrode assembly containing an electrically conductive fluid and adapted to dispense the fluid against the surface of the skin to which it is operatively attached in use, said assembly comprising:

a main portion of electrically conductive material having a central opening therethrough and a skin contacting area at one end of said central opening;

means for securing the assembly to the body of the user;

an electrically conductive connector portion disposed in an initial position within said central opening at the end thereof opposite to said skin contacting area, said main and connector portion adapted to permit movement of said connector portion in said central opening toward said skin contacting area, said main portion and said connector portion mutually configured so as to provide a chamber for fluid therebetween with said connector portion in said initial position, said chamber becoming smaller as a consequence of said connector portion being moved toward said skin contacting area; and

an electrically conductive fluid material disposed in said chamber and adapted to be dispersed from said one end of said central opening when said connector portion is moved toward said skin contacting area.

2. The electrode assembly according to claim 1 additionally comprising:

a membrane disposed at the skin contacting area end of said central opening to isolate said conductive fluid from the atmosphere, said membrane comprising a peeloff layer adapted to be removed prior to operatively contacting said assembly to the skin.

3. The electrode assembly according to claim 1 wherein said connector portion includes a cavity therein, said cavity opening toward said skin contacting area end, and wherein said conducting fluid is disposed within said cavity; and further comprising:

a membrane disposed across said cavity opening of said connector portion and sealing off said cavity to isolate said conducting fluid from the atmosphere; and

means disposed in said main portion in the skin contacting area end of said central opening for piercing said membrane as a consequence of relative motion of said connector portion toward said skin contacting area.

60

65

70

75