

[54] **APPARATUS FOR FEEDING ARTICLES AT CONSTANT RATE**

[75] Inventor: **Harumi Yamada**, Kashihara, Japan

[73] Assignee: **Koyo Lindberg Hevi Duty Company, Limited**, Osaka, Japan

[22] Filed: **Aug. 10, 1971**

[21] Appl. No.: **170,506**

[30] **Foreign Application Priority Data**

Aug. 14, 1970 Japan.....45/71646

[52] U.S. Cl.222/167, 222/306, 222/411, 221/186

[51] Int. Cl.**B67d 5/64**

[58] Field of Search.....222/367, 370, 355, 222/302, 303, 304, 305, 307, 167, 411, 160, 306, 444; 221/186

[56] **References Cited**

UNITED STATES PATENTS

3,426,688	2/1969	Jones.....	222/367 X
3,311,272	3/1967	Westbrook.....	222/355
1,214,776	2/1917	Greenfield.....	232/167 X

640,141 12/1899 Lombas.....222/367 X

Primary Examiner—Robert B. Reeves

Assistant Examiner—James M. Slattery

Attorney—Charles R. Fenwick, Thomas B. Van Poole, S. Ellwood Wilson et al.

[57] **ABSTRACT**

A rotatable drum for receiving articles to be measured out is formed with a recess defined by an outwardly jutting wall of the drum and a passage communicating with the recess. A measuring section includes an independent compartment within the drum formed with a window and has a measuring member whose position is adjustable with respect to the window to control the volume of the articles to be determined by the measuring section. Due to the rotation of the drum, the articles are collected in the recess and then carried through the passage to the measuring section, where the measuring member receives the articles at the adjusted position and permits a constant amount of the articles to be sent into the compartment. An excess amount of the articles are sent back to the interior of the drum through the window. The articles in the compartment are then sent out of the drum by way of a delivery path.

3 Claims, 2 Drawing Figures

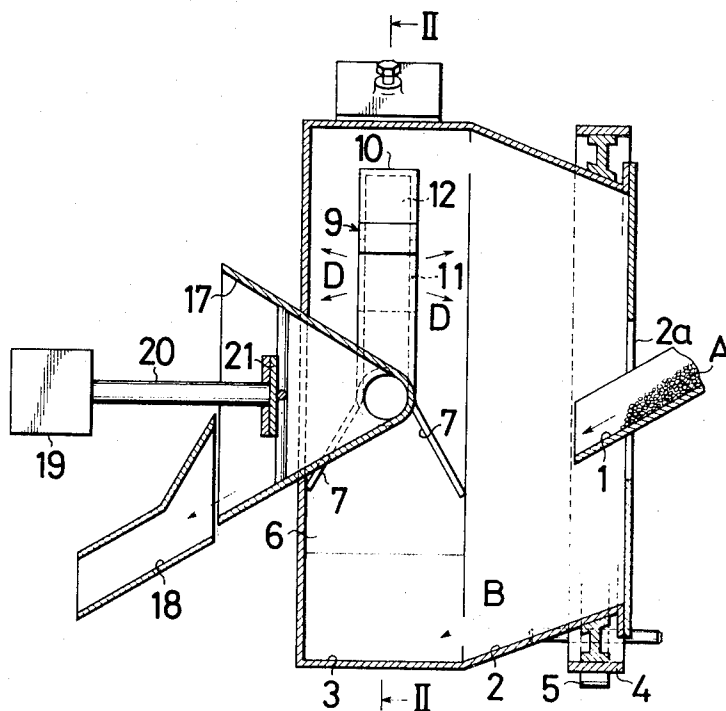

Fig.1

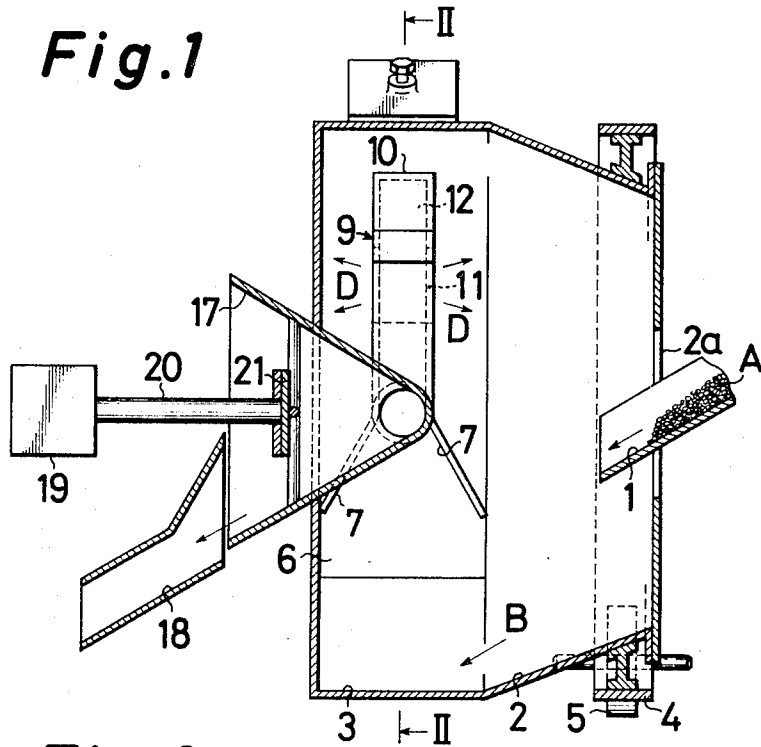
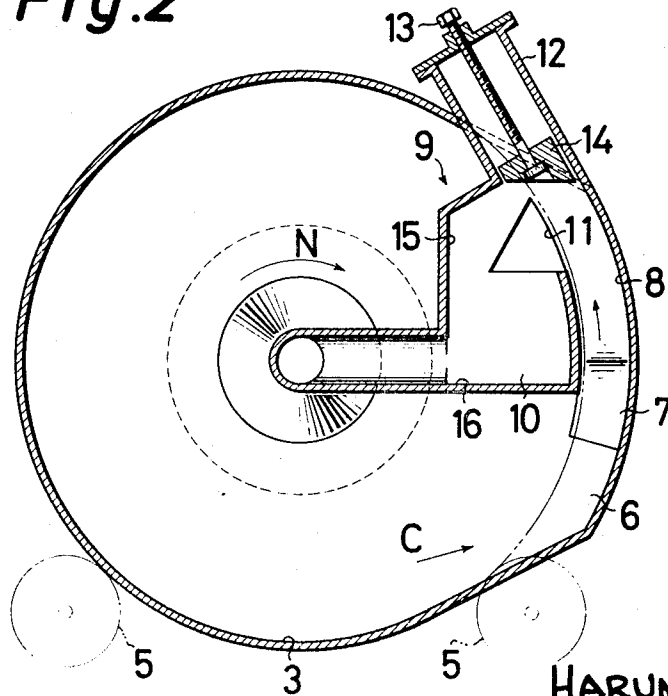

Fig.2



INVENTOR
HARUMIYAMADA
BY
Mason, Fenwick & Lawrence
ATTORNEYS

APPARATUS FOR FEEDING ARTICLES AT CONSTANT RATE

BACKGROUND OF THE INVENTION

The present invention relates to an apparatus for feeding articles such as granules, relatively short rods, cylindrical articles or the like at a constant rate to a subsequent process.

In the case where a predetermined amount of various small parts or articles are fed to a subsequent process or to a packaging process at plants for manufacturing machines and parts for electrical appliances, it is very troublesome to count the number of the parts one by one. To eliminate such trouble, the articles may be batched, but even in this case measurement is conducted manually with low efficiency.

For improved production, it has been suggested to rationalize the supply line in recent years. From this viewpoint, the above-mentioned method of measurement which requires labor is by no means efficient.

SUMMARY OF THE INVENTION

An object of this invention is to provide an apparatus for automatically feeding granules, relatively short rod-like articles, cylindrical articles or the like always at a constant rate by each cycle of feeding operation.

Another object of this invention is to provide an apparatus of the type described for feeding articles at a constant and yet readily controllable rate.

Another object of this invention is to provide an apparatus of the foregoing type which can be installed at an intermediate portion of a supply path such as a chute or the like for automatically conveying the articles from one process to another.

The apparatus of this invention comprises a rotatable drum for receiving articles to be fed formed with a recess defined by an outwardly jutting wall of the drum, guide walls extending upright from the inner face of the drum for guiding the articles collected in the recess, a passage defined by the extension of the outwardly jutting wall for passing the articles guided by the guide walls, a measuring section including an independent compartment within the drum for receiving the articles from the passage and discharging the articles at a constant rate upon measurement, and a delivery path for sending out the articles from the measuring section to the outside of the drum by the rotation of the drum. The measuring section is formed with a window for returning an excess amount of the articles to the interior of the drum and has a measuring member whose position is adjustable with respect to the window to control the volume of feed to be determined by the measuring section. The articles supplied from the passage is received by the measuring member at the adjusted position, whereby a constant amount of the articles are sent into the compartment and an excess amount of the articles are returned to the interior of the drum.

The drum is further formed at its one side with an inlet for receiving the articles from transport means such as a chute and has at the other side an outlet of the delivery path for feeding the articles at a constant rate to a subsequent process by way of transport means such as a chute.

In accordance with this invention, the articles supplied into the rotating drum are collected in the recess and then sent into the measuring section through the passage. The amount of the articles are limited when

they pass through the passage, and at the measuring section the articles in excess of the volume determined by the measuring member are sent back to the interior of the drum through the window. Due to the continuous rotation of the drum, the articles measured out are carried through the delivery path onto the transport means for conveying the articles to the next process.

By adjusting the position of the measuring member with respect to the window, the volume of the articles to be measured out at the measuring section by one cycle of operation is suitably determined.

It will be apparent from the foregoing description that the apparatus of this invention may be installed at an intermediate portion of a supply path to feed articles automatically at a constant rate.

The articles to be fed at a constant rate by the apparatus of this invention are not limited to the parts of machines and electrical appliances, but any articles in granular, rodlike, cylindrical or like form such as grains or processed foods can also be measured.

Other objects and advantages of this invention will become more apparent from the following description.

BRIEF DESCRIPTION OF THE DRAWING

FIG. 1 is a front view in vertical section showing the construction of principal part of an embodiment of this invention; and

FIG. 2 is a side elevation showing the principal part in section taken along the line II — II in FIG. 1.

DESCRIPTION OF THE PREFERRED EMBODIMENT

Referring to the drawing, indicated at A are articles to be measured which are supplied by transport means 1 such as a chute. The articles may be in the form of granules, rods, cylinders, or in any desired form. The transport means 1 may be a chute as illustrated or a hopper, conveyor, a gravity-feeding chute or any desired means.

The chute 1 extends into an opening 2a at the center of the end face of a tapered cylindrical portion 2 extending from a drum 3 and supplies the articles A to be measured into the drum 3. Provided externally around the drum 3 is a guide rail 4 which is placed on guide rollers 5 rotatably supported on unillustrated support means. Drive means to be described later rotates the drum 4 at a constant speed.

The drum 3 further includes a recess 6 defined by an outwardly jutting wall of the drum 3 into which the articles A supplied into the drum 3 are collected by the rotation of the drum 3. Guide walls 7 disposed at the opposite sides of the recess 6 extend upright from the inner face of the drum 3 to conduct the articles A from the recess 6 into a passage 8 extending along the outer wall of the drum 3 and communicating with a measuring section 9.

The measuring section 9 is defined by a partition 10 which forms an independent compartment within the drum 3. A window 11 permitting the measuring section 9 to communicate with the interior of the drum 3 is formed in the partition 10. The measuring section 9 further includes adjusting means 12 incorporating therein a measuring block 14 whose position is adjustable by an adjusting bolt 13 with respect to the window 11. The block 14 serves as a measuring member and is so positioned as to receive the articles A sent through the channel 8 by virtue of the rotation of the drum 3.

The constant rate of feed of the articles as determined by the measuring section 9 can be controlled by adjusting the position of the block 14 relative to the window 11 and an excess amount of the articles A are returned to the interior of the drum 3 by way of the window 11.

Arranged subsequent to the measuring section 9 are delivery passages 15 and 16 for discharging the measured amount of the articles from the measuring section 9 at a constant rate by the rotation of the drum 3. The passage 16 communicates with a flaring outlet chute 17 disposed at the center of the end of the drum 3. Positioned below the chute 17 is another chute 18 or some other means for transporting the articles to the next process.

To drive the drum 3, the output shaft 20 of a reduction gear to be operated by a motor or the like is connected to the drum 3 by a coupling 21. The drum 3 is driven on the guide rollers 5 at a constant speed in the direction of an arrow N in FIG. 2.

In the foregoing apparatus, the articles A supplied into the drum 3 are carried forward by the rotation of the drum 3 in the direction of the arrow N in FIG. 2. When charged into the drum 3 by means of the chute 1, the articles are moved within the drum 3 in the direction of an arrow B and the rotation of the drum 3 sends them toward the direction of an arrow C into the recess 6 and then into the passage 8 along the guides 7. At this time, the articles other than those led into the passage 8 pass over the guide walls 7, along the inner face of the drum 3 and back into the recess 6 again due to the continuous rotation of the drum. The articles are then sent into the passage 8.

After passing through the passage 8, the articles abut the measuring block 14 at the measuring section 9, whereupon a given amount of the articles as determined by the position of the block 14 relative to the window 11 are sent forward along the delivery passages 15 and 16 and discharged from the outlet chute 17, while an excess amount of the articles are sent out through the window 11 to the interior of the drum 3 as indicated by arrows D. In this manner, the articles are fed to the next process at a constant rate every time the drum 3 makes one turn of rotation.

More specifically, when the drum 3 rotates about 60° from the position of FIG. 2 in the direction of the arrow

N, the articles are collected in the recess 6. When the drum 3 further rotates about 150° from this position, measurement is conducted at the measuring section and the articles measured out are then sent out of the drum by way of the delivery path as the drum further rotates.

The window 11 may be of a desired shape, insofar as it does not permit the articles measured out to return to the interior of the drum after measurement.

What is claimed is:

1. An apparatus for feeding articles at a constant rate comprising, a drum rotatable in a given direction at a constant speed and formed with a recess defined by an outwardly jutting wall of said drum for collecting the articles supplied into said drum for measurement and a passage defined by the extension of said wall and communicating with said recess, guide plates having a given height for guiding the articles from said recess into said passage, a measuring section including an independent compartment communicating with said passage, said measuring section having a window formed in a partition wall between said compartment and said drum and adjustable means supporting a movable measuring member for bodily adjustment with respect to said window for receiving the articles sent through said passage and determining the volume of the articles by the position of said measuring member with respect to said window to permit an excess amount of the articles to be sent back to the interior of the drum through said window, and a delivery path defining means extending from said compartment to an outlet of said drum for discharging the articles measured out at said measuring section from said drum by the rotation of said drum.

2. The apparatus as set forth in claim 1 wherein said adjustable means for adjusting the position of said measuring member with respect to said window to thereby control the volume of the articles to be determined by said measuring section includes adjustable screw means connected to said measuring member.

3. The apparatus as set forth in claim 1 wherein said drum is formed at the center of one end thereof with an opening for supplying the articles directly from transport means and said outlet is a flaring outlet chute formed at the center of the other end of said drum.

* * * * *

50

55

60

65