

Dec. 30, 1952

G. D. HAVER

2,623,378

ADJUSTABLE LOCKING DEVICE

Filed Dec. 27, 1948

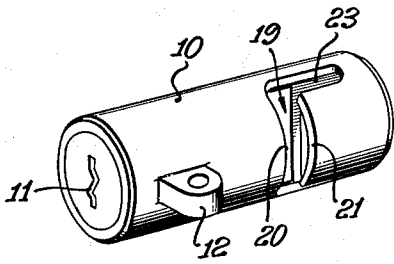

Fig. 1.

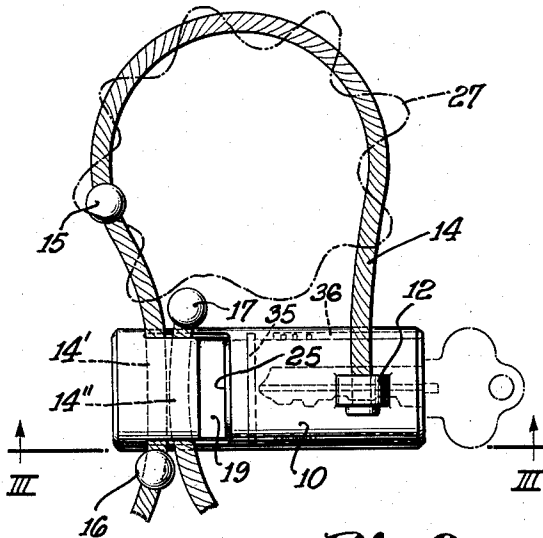

Fig. 2.

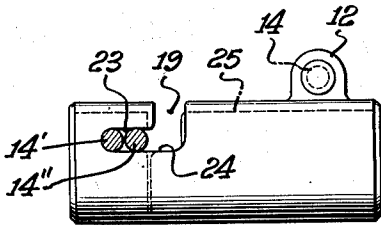

Fig. 3.

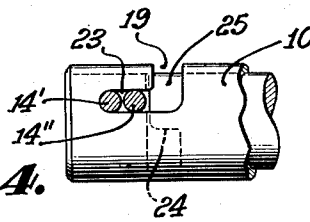

Fig. 4.

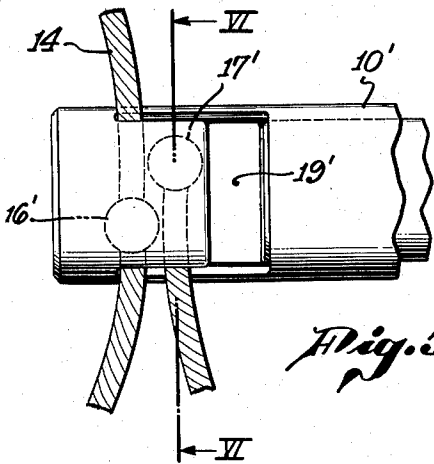

Fig. 5.

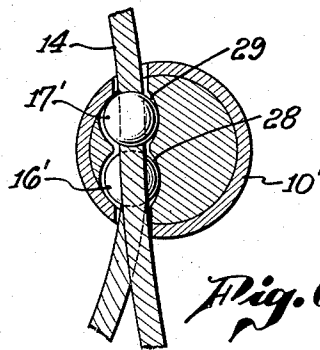

Fig. 6.

INVENTOR.
GABRIEL D. HAVER,
BY

C. J. [Signature]
ATTORNEY.

UNITED STATES PATENT OFFICE

2,623,378

ADJUSTABLE LOCKING DEVICE

Gabriel D. Haver, National City, Calif.

Application December 27, 1948, Serial No. 67,290

4 Claims. (Cl. 70-49)

1

This invention pertains to an adjustable locking device and is particularly directed to a key-operated adjustable lock whereby two elements or articles may be inseparably connected. Even more particularly stated, the invention pertains to an adjustable locking device particularly adapted for use in closing and securely locking a dunnage bag such as a seaman's bag, and providing means whereby the bag, after being thus locked or closed, can be lashed or secured to a stanchion, pipe, or other relatively immovable and fixed object so that the bag is locked and anchored. Similarly, objects such as motorcycles, bicycles and the like, may be locked and anchored to a fixed object.

Locking devices capable of closing and locking a bag or the like and simultaneously including means whereby the locked bag may be anchored to a fixed object are disclosed in my co-pending application Serial No. 609,289, now abandoned, and employ a flexible cable provided with a plurality of spaced, enlarged, stop elements, the flexible cable permitting locking means to be adjusted to any desired size or position. In the device disclosed in my prior application, however, a padlock was employed in actually latching or holding the locking means in locked position. The present invention is directed to an improved form of device in which the flexible cable is an inseparable part of a cylinder lock, the device thereby being a complete, self-contained, adjustable unit of low weight, great strength, and remarkable flexibility in that it is capable of being employed under a great variety of conditions.

Generally stated, the present invention relates to a rigid locking element capable of receiving a key for its actuation, said locking element having a flexible cable permanently connected thereto and including means for removably securing spaced portions of the cable thereto to thereby provide two separate loops rigidly connected to the locking bar, said loops locking and anchoring various devices to a stanchion, post or other object.

An object of the present invention, therefore, is to disclose and provide a simple and efficient construction for an adjustable locking device.

A further object of the invention is to disclose and provide a relatively light weight, adjustable locking device employing a flexible cable.

A still further object of the device is to disclose and provide a key-operated adjustable locking device adapted to form and releasably hold two separately disposed loops of cable, each loop resisting enlargement.

2

These and various other objects of the invention will become apparent to those skilled in the art from the following description which will be amplified, in order to facilitate understanding, by reference to the appended drawings, in which:

Fig. 1 is a perspective view of the locking bar without its associated cable.

Fig. 2 is a side elevation indicating one illustrative position of a cable with respect to the locking bar.

Fig. 3 is a plan view taken along the plane III-III of Fig. 2.

Fig. 4 is a plan view of a portion of the locking bar with the bolt in locked position.

Fig. 5 is a side elevation of a portion of the locking bar of a slightly modified form.

Fig. 6 is a transverse section taken along the plane VI-VI of Fig. 5.

The rigid locking element or locking bar of the present invention preferably comprises a cylindrical housing 10 containing a well known cylinder lock having a partially rotatable plug provided with a suitably shaped opening 11 adapted to receive a key. The partially rotatable plug is suitably keyed into the housing to prevent longitudinal movement of the plug within the housing. The keyhole is preferably positioned in one end of the locking bar. It is to be understood that the locking bar need not be cylindrical, as shown in the drawings, but may be of polygonal cross section if desired.

The housing may be provided with an outstanding ear or lug 12 which may be ported so as to receive one end of a flexible cable 14, as best shown in Fig. 2. The cable 14 may be soldered into the port of the ear 12 or it may be otherwise firmly and irremovably connected to the ear. The cable 14 is preferably of appreciable length and provided with a plurality of spaced, enlarged, stop elements, such as the balls 15, 16, 17, etc. These various stop elements or balls may be swedged, pressed, brazed, or otherwise attached to the flexible cable 14.

The housing of the pear-shaped locking element is provided with a transversely extending groove in a side wall of said housing, the bottom portion of said groove being in communication with a longitudinally disposed slot so as to form a tongue from a portion of the side wall of the housing.

The transversely extending groove 19 may be defined by the parallel walls 20 and 21, the corners or edges of the housing around such groove being suitably rounded. Inasmuch as the housing 10 is cylindrical, the groove 19 may be

3

said to have an open front and open opposing ends. The bottom portion of this groove 19 communicates with a longitudinally extending slot 23 also having open ends. Preferably the slot 23 extends from the groove 19 in a direction away from the keyhole end 11 of the cylinder lock.

The groove 19 and slot 23 are sufficiently wide to receive a section of the cable. The bottom 24 of the groove 19 constitutes a face of a bolt head 25 rotatably positioned within the housing and selectively rotatable by actuation of the cylinder lock. The bolt head 25 is a part of the rotary plug of the cylindrical lock. The end of the bolt head, provided with the face 24 is of semi-circular cross-section whereas the rest of the rotary plug is rotatably mounted within the housing 10 as by means of an expansion ring 35 cooperating between a circular groove formed on the inner face of the housing 10 and a groove formed in the rotary plug. The inner surfaces of the housing 10 are provided in the customary manner with a pair of opposed longitudinally extending grooves 36 into which the tumblers carried by the rotary plug extend when the device is in locked position and from which they are withdrawn by the key. The slot 23 extends longitudinally a distance sufficient to receive two adjacent sections of cable, as best illustrated in Figs. 3 and 4. It will be noted that when in unlocked position (Fig. 3) the face 24 of the bolt head 25 extends between ends of groove 19 and is in alignment with the inner wall of slot 23; when the bolt head 25 is rotated 180° in a plane transverse to the slot 23 into the position shown in Fig. 4, then the curved or cylindrical outer surface of the bolt head acts as a plug for groove 19 and isolates slot 23 (which extends beyond the plane of rotation of the bolt head) from the groove, thereby preventing cable in slot 23 from being withdrawn into groove 19.

The operation of the device can be readily understood from a consideration of an example. If, for instance, it is desired to close a sea-bag, the loose or free end of the cable (shown provided with a stop 17) is threaded through the grommet holes of a sea-bag indicated diagrammatically at 27. By pulling on the free end of the flexible cable 14, the neck of the sea-bag may be constricted until the locking bar 10 is immediately adjacent the constricted neck of the sea-bag.

A section of the cable immediately adjacent the sea-bag is then inserted into the groove 19 and this section of the cable, indicated at 14', is permitted to extend into the longitudinal slot 23. Since a number of stop elements, such as 15, and 16, are carried by the cable, the tensioning of the devices around the neck of a sea-bag is carried out until one of these stops, such as the stop 16, is just beyond the locking bar 10. When the section 14' slips into the slot 23, the stop element immediately adjacent said slot, such as the stop element 16, will bear against the outer surfaces of the locking bar 10 and hold the neck of the sea-bag in its constricted position. It will be noted that the expanding force of the cable tends to more firmly hold the section 14' of the cable within the slot 23.

If it is only desired to lock the sea-bag, the cylinder lock may be actuated by a suitable key, causing a partial 180° rotation of the bolt 25, the bolt in its locked position closing the groove 19, as illustrated in Fig. 4. If, however, it is desired to not only lock the sea-bag but also to anchor it

4

to a stanchion or other fixed object, then the free end of the cable 14 is passed around a pipe, stanchion, or other fixed object and the free end of the cable introduced through the groove 19 into the slot 23 so as to place the section 14' of the cable in the position indicated in Fig. 3. The cylinder lock is then returned with the appropriate key and as shown in Fig. 4, the bolt 25 will firmly lock both sections of cable in position, the free end of the cable being irremovably held by the locking bar by reason of the enlarged stop element 17.

It is understood that in Fig. 2 the complete lower loop is not indicated in order to conserve space, but the broken ends of the cable are joined and carry additional stop elements, not shown.

Details of the cylinder lock are not shown since they form no part of the present invention. Cylinder locks capable of locking a bolt in two positions, one 180° removed from the other, are well known in the art.

It is to be noted that in the device illustrated in Figs. 2, 3 and 4 the stop elements, such as 16 and 17, being larger than the groove 19 and slot 23, are held exteriorly of the locking bar 10. The modification illustrated in Figs. 5 and 6 shows a construction wherein the stop elements are enclosed by the housing. In this form of construction the groove 19' is sufficiently wide to admit the stop elements 16' and 17' and the walls of the slot 23 are formed with recesses or indentations 28 and 29 adapted to receive the stop elements.

Although specific reference has been made to the utilization of the locking device with respect to a sea-bag, it is to be understood that the invention is not limited to this use but may be employed wherever it is deemed necessary or desirable to join two or more articles together, or to encircle and hold or lock a single object or article. For example, the device can be employed to good advantage in firmly connecting a number of pieces of luggage so as to prevent their disposal. Numerous modifications and changes can be made in the construction of the device and all changes and modifications coming within the scope of the appended claims are embraced thereby.

I claim:

1. An adjustable locking device including a virtually cylindrical hollow locking bar containing a key-operated, partially rotatable cylinder-type lock comprising, in combination: a semi-cylindrical locking bolt head in the locking bar and selectively operable by the cylinder lock; the locking bar being provided with a transversely extending cable-receiving groove, a face of the locking bolt head extending between ends of the groove when the lock is in open position, and a longitudinally extending slot in communication with each end of the groove and arranged to receive two adjacent sections of flexible cable, said bolt head being arranged to close the transverse groove when the lock is in closed position; and a length of flexible cable carrying a plurality of fixed, spaced, enlarged stop elements, one end of the cable being fixedly connected to the locking bar, the stops being larger than the slot to limit movement of the cable held within the slot by the bolt head when the latter is in closed position.

2. In an adjustable locking device including a rigid, elongated locking bar containing a key-operated, partially rotatable, cylinder-type lock

5

and a locking bolt head, the provision of: a flexible cable carrying a plurality of spaced, enlarged stop elements, means carried by the locking bar for permanently holding one end of the flexible cable; a groove formed in the locking bar transversely thereto, and a longitudinally extending slot in communication with each end of the groove, said groove and slots being adapted to receive a section of the flexible cable; the locking bolt head being segmental in form and arranged to form a wall of the groove when the lock is in open position and to selectively close the transversely extending groove to retain two adjacent sections of flexible cable in the longitudinal slot when in closed position.

3. An adjustable locking device including: a rigid, elongated walled housing; a key operated, partially rotatable cylinder lock carried within the housing at one end thereof; a flexible cable carrying a plurality of spaced, enlarged stop elements; means carried by the housing for permanently holding one end of the cable; the wall of the housing being provided with a transversely extending groove and a longitudinally extending dead end slot in communication with each end of the groove; said groove and slot being arranged to receive a section of said cable, said slot being of such width as to prevent passage of a stop element when the cable is in the slot and is moved longitudinally; and a bolt head within the housing and operably associated therewith for partial rotation in a transverse plane in the housing, said bolt head being virtually semi-cylindrical and having a face arranged to extend between opposing ends of the groove when the locking device is in unlocked position, said slot extending away from the plane of rotation of said bolt head, said bolt head having a semi-cylindrical surface arranged to close said groove and prevent withdrawal of said cable from said

6

slot into the groove without pressure contact against the cable when the bolt head is partially rotated into locked position.

4. In an adjustable locking device including a rigid, elongated housing provided with a key operated, partially rotatable cylinder lock carried within the housing at one end thereof, the provision of: a flexible cable carrying a plurality of spaced, enlarged stop elements; means carried by the housing for permanently holding one end of the cable; the housing being provided with a transverse groove and a longitudinally extending slot in communication with the bottom of the groove, said groove and slot being arranged to receive a section of said cable, the width of the slot being insufficient to permit stop elements to pass therethrough when a cable section is moved longitudinally; a virtually semi-cylindrical bolt head within the housing and operably associated with the cylinder lock for partial rotation in a transverse plane; said bolt head having a face arranged to extend between ends of the groove when the locking device is in unlocked position, said slot extending away from the plane of rotation of the bolt head, said bolt head having a semi-cylindrical surface arranged to plug the groove and isolate the slot when said bolt head is partially rotated into locked position.

GABRIEL D. HAVER.

REFERENCES CITED

The following references are of record in the file of this patent:

UNITED STATES PATENTS

Number	Name	Date
1,358,184	Voight	Nov. 9, 1920
2,440,012	Haver	Apr. 20, 1948