

(12) PATENT
(19) AUSTRALIAN PATENT OFFICE

(11) Application No. AU 199933197 B2
(10) Patent No. 719660

(54) Title
Structure body and hollow shape extruded frame member

(51)⁷ International Patent Classification(s)
F16S 001/02 B61D 017/04

(21) Application No: **199933197** (22) Application Date: **1999.06.07**

(30) Priority Data

(31) Number	(32) Date	(33) Country
10-168016	1998.06.16	JP

(43) Publication Date : **1999.12.23**

(43) Publication Journal Date : **1999.12.23**

(44) Accepted Journal Date : **2000.05.11**

(71) Applicant(s)
Hitachi, Ltd.

(72) Inventor(s)
Masakuni Ezumi; Akihiro Satou; Kazusige Fukuyori; Takeshi Kawasaki

(74) Agent/Attorney
DAVIES COLLISON CAVE, 1 Little Collins Street, MELBOURNE VIC 3000

(56) Related Art
WO 82/00313
EP 151550
AU 66112/94

Abstract of the Disclosure :

End portions of face plates 111 and 112 of a frame member 110 are connected by a rib 116A. To protrusion
5 chips 117b1 and 117b2 end portions of face plates 101 and 102 of another frame member 100 are overlapped. A connection line between the rib 116A and a rear face of the face plates 111 and 112 are connected by a circular arc 131 which protrudes to a side of a hollow portion 119
10 of the frame member 110. Both end portions of the circular arc 131b1 is connected to the rib 116A and the face plates 111 and 112 by two smooth recessed circular arcs 132b1 and 133b1. Accordingly, since a flow-out of a metal does not occur from this portion, a cross-section
15 can be small and a light weight structure can be obtained. A hollow shape frame members which is joined according to a friction stir welding is to provide a light weight structure.

AUSTRALIA
PATENTS ACT 1990
COMPLETE SPECIFICATION

NAME OF APPLICANT(S):

Hitachi, Ltd.

ADDRESS FOR SERVICE:

DAVIES COLLISON CAVE
Patent Attorneys
1 Little Collins Street, Melbourne, 3000.

INVENTION TITLE:

Structure body and hollow shape extruded frame member

The following statement is a full description of this invention, including the best method of performing it known to me/us:-

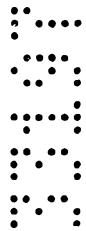

Background of the Invention :

5 The present invention relates to a structure body
and a hollow shape extruded frame member manufactured by
using a friction stir welding manner, etc. and relates
particularly to a joint shape of a structure body using a
friction stir welding manner, etc. and a joint shape of a
10 hollow shape extruded frame member using a friction stir
welding manner, etc..

 The present invention relates to a structure body
and a hollow shape extruded frame member using a friction
stir welding manner and relates particularly to suited to
15 the structure body for example, such as an aluminum alloy
member which is used in a railway vehicle and a structural
building construction.

 As described in Japanese application patent laid open
publication No. Hei 9-309164 (EP 0797043 A2), a friction
20 stir welding method is a method in which by rotating a
round rod (it is called as a rotary body) which is
inserted to a joining portion of hollow shape extruded
frame members to be subjected to joining and by moving the
rotary rod along to a joining line of the frame members to
25 be subjected to joining, then the joining portion of the
frame members to be subjected to joining is exothermical
heated and softened and the joining portion is elastically

fluidized and is carried out to form a solid joining.

The rotary body for carrying out the friction stir welding comprises a small diameter portion which is inserted to the joining portion and a large diameter portion which is positioned at an outside portion. The small diameter portion and the large diameter portion of the rotary body have the same axis. A boundary face portion between the small diameter portion and the large diameter portion of the rotary body is inserted a little to the joining portion. The joining according to the friction stir welding is applied to an abutted portion of the frame members and an overlap portion of the frame members.

As shown in the above stated prior art, a protrusion portion of the frame member is provided to the joining portion of the frame member to be subjected to joining. This protrusion portion of the frame member is protruded to a side of the rotary body, and the protrusion portion of the frame member is carried out to join using the friction stir welding manner.

Further, as shown in the above stated prior art, a protrusion chip is provided to the joining portion of the frame member to be subjected to joining. This protrusion chip is protruded from a rib of an end portion of a hollow shape extruded frame member of one of the frame members to be subjected to joining to a side of another hollow shape extruded frame member to be subjected to joining. To

this protrusion chip a face plate of the another hollow shape extruded frame member is overlapped.

Since the friction stir welding is that by inserting the rotary body being a joining tool to the hollow shape frame members to be subjected to joining and a metal is fluidized, a large force works on the frame members to be subjected to joining. Namely, the large force is a force for inserting the rotary body into the frame members to be subjected to joining and the frame members to be subjected to joining is necessary to endure the above stated large force.

As a result, when the hollow shape extruded frame members are joined, as shown in the above stated prior art, the metal is flown easily to a rear side. Therefore, it is necessary to form large the protrusion portion of the hollow shape extruded frame members for supplementing the flown metal. Further, void holes occur easily to a joining bead of the frame members.

As one means for preventing the above stated various defects shown in the above stated prior art, a thickness of the frame member to be subjected to joining of the joining portion is made thick, thereby the flow-out of the metal from the frame members to be subjected to joining can be prevented.

For example, making large a circular arc of a connection line between the face plate and the rib on the joining portion of the frame member, thereby a thickness of

an outer portion of the frame member to be subjected to joining is made thick. Further, for example, making large a diameter of the circular arc of a joining line between the protrusion chip and the rib of the frame member, thereby the thickness of the 5 outer portion of the frame member to be subjected to joining is made thick.

The above stated circular arc of the frame member to be subjected to joining is recessed to a side of the face plate of the frame member. Accordingly, a cross sectional area of the 10 frame member to be subjected to joining becomes large and then a weight of the frame member to be subjected to joining increases.

Summary of the Invention :

15 According to the present invention, there is provided a structure body characterized in that:

a first member having substantially parallel two first face plates and plural first ribs for connecting said two first face plates; and

20 a second member having substantially parallel two second face plates and plural second ribs for connecting said two second face plates;

said first member and said second member are joined according to two joining beads;

25 one of said two joining beads joins one of said two first face plates of said first member and said one of said two joining beads joins one of said two second face plates of said second member;

another of said two joining beads joins another of said two 30 first face plates of said first member and said another of said two joining beads joins another of said two second face plates of said second member; and

a first connection line between said first rib of said first member at a vicinity of the one of said two joining beads

5
10
15
20

25
30



and a rear face of said one of said two first face plates of said first member at a position of a first hollow portion of said first member is a first circular arc shape protrusion arc which is protruded to a side of said first hollow portion of said
5 first member.

According to the present invention, there is provided a structure body characterized in that:

a first member having substantially parallel two first face plates and plural first ribs for connecting said two first face
10 plates; and

a second member having substantially parallel two second face plates and plural second ribs for connecting said two second face plates;

said first member and said second member are joined
15 according to two joining beads;

one of said two joining beads joins one of said two first face plates of said first member and said one of said two joining beads joins one of said two second face plates of said second member;

20 another of said two joining beads joins another of said two first face plates of said first member and said another of said two joining beads joins another of said two second face plates of said second member;

a first connection line between said first rib of said
25 first member at a vicinity of said one of said two joining beds and a rear face of said one of said two first face plates of said first member at a position of a first hollow portion of said first member is a first circular arc shape protrusion arc which is protruded to a side of said first hollow portion of
30 said first member; and

a second connection line between said first rib of said first member at a vicinity of said another of said two joining beads and a rear face of said one of said two first face plates of said first member at a position of said first hollow portion



of said first member is a second circular arc shape protrusion arc which is protruded to said of said first hollow portion of said first member.

The invention also provides a structure body characterized 5 in that:

a first member having substantially parallel two first face plates and plural first ribs for connecting said two first face plates; and

a second member having substantially parallel two second 10 face plates and plural second ribs for connecting said two second face plates;

said first member and said second member are joined according to two joining beads;

one of said two joining beads joins one of said two face 15 plates of said first member and said one of said two joining beads joins one of said two second face plats of said second member;

another of said two joining beads joins another of said two first face plates of said first member and said another of said 20 two joining beads joins another of said two second face plates of said second member;

said two joining beads are positioned respectively at an intermediate portion between said first rib of said first member and said second rib of said second member;

25 one of said two second face plates of said second member is overlapped to a protrusion chip which is protruded directing for from said first rib at a vicinity of said one of said two joining beads to said second member;

a first connection line between said first rib at the 30 vicinity of said one of said two joining beads and a rear face of one of said first face plate at a position of a first hollow portion of said two first members is a first circular arc shape protrusion arc which is protruded to a side of said first hollow portion of said first member; and

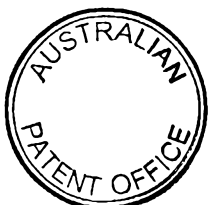

a second connection line between said second rib at the vicinity of said one of said two joining beads and a rear face of one of said two second face plates at a position of a second hollow portion of said second member is a third circular arc shape protrusion arc which is protruded to a side of said second hollow portion of said second member.

The invention further provides a structure body characterized in that:

a first member having substantially parallel two first face plates and plural first ribs for connecting said two first face plates; and

a second member having substantially parallel two second face plates and plural second ribs for connecting said two second face plates;

said first member and said second member are joined according to two joining beads;

one of said two joining beads joins one of said two first face plates of said first member and said one of said two joining beads joins one of said two second face plates of said second member;

another of said two joining beads joins another of said two first face plates of said first member and said another of said two joining beads joins another of said two second face plates of said second member;

a first connection line between said first rib of said first member at a vicinity of said one of said two joining beads and a rear face of one of said two first face plates of said first member at a position of a first hollow portion of said first member is a first circular arc shape protrusion arc which is protruded to a side of said first hollow portion of said first member;

a second connection line between said second rib of said second member at a vicinity of said one of said two joining beads and a rear face of one of said two second face plates of



said second member at a position of a second hollow portion of said second member is a second circular arc shape protrusion arc which is protruded to said side of said second hollow portion of said second member;

5 a third connection line between said first rib of said first member at a vicinity of said another of said two joining beads and a rear face of another of said two first face plates of said first member at a position of said first hollow portion of said first member is a third circular arc shape protrusion
10 arc which is protruded to said side of said first hollow portion of said first member; and

a fourth connection line between said second rib of said second member at a vicinity of said another of said two joining beads and a rear face of another of said two second face plates
15 of said second member at a position of said second hollow portion of said second member is a fourth circular arc shape protrusion arc which is protruded to said side of said second hollow portion of said second member.

The invention further provides in a hollow shape extruded
20 frame member having substantially parallel two face plates and plural ribs for connecting said two face plates, characterized in that

a connection line formed between said rib of at least one end portion of said hollow shape extruded frame member and a
25 rear face of said face plate at a position of a hollow portion of said hollow shape extruded frame member is a circular arc shape protrusion arc which protrudes to a side of said hollow portion of said hollow shape extruded frame member.

Embodiments of the present invention provide a structure
30 body wherein a light weight joint member or a light weight joining portion member of the structure body can be attained and a hollow shape extruded frame member wherein a light weight joint member or a light weight joining portion member of the hollow shape extruded frame member can be attained.

Embodiments of the present invention provide a structure

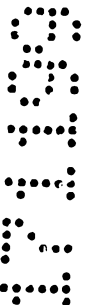
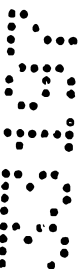

body wherein a small cross-sectional area of the structure body can be obtained and a hollow shape extruded frame member wherein a small cross-sectional area of the hollow shape extruded frame member can be obtained.

5 In embodiments of the invention a connection line between a rib at a vicinity of a joining portion and a face plate of the structure body or the hollow shape extruded frame member exists to be a center or a connection line between a protrusion chip and a rib of the structure body or the hollow shape extruded
10 frame member which is formed with a circular arc in which a side of a joining portion exists to be a center, namely a circular arc is protruded to a side of a hollow portion of the structure body or the hollow shape extruded frame member.

15 Brief Description of the Drawings :

Fig. 1 is a partially enlarged longitudinal cross-sectional view showing a structure body having a joint member for use in a friction stir welding of one embodiment according to the present invention;

20 Fig. 2 is a partially enlarged longitudinal cross-sectional view of a structure body which is comprised of two hollow shape extruded frame members using the joint member of the structure body shown in Fig. 1; and

25 Fig. 3 is a partially enlarged longitudinal cross-sectional view showing a structure body having a joint member for use in a friction stir welding of another embodiment according to the present invention.



Description of the Invention :

A structure body of one embodiment according to the present invention will be explained referring to Fig. 1 and Fig. 2. A member to be subjected to joining by using, for example, a friction stir welding is a metal material, for example, such an aluminum alloy hollow shape extruded frame member. By joining these frame members, a structure body, for example, such a car body of a railway vehicle is manufactured. According to an employment of plural frame members, a side body structure, a roof body structure, an end body structure, and a floor body structure of the car body of the railway vehicle are constituted.

In a case of the side body structure and the roof body structure of the car body of the railway vehicle, a length of the frame member for constituting the side body structure or the roof body structure is similar to a length of the car body of the railway vehicle at the maximum. A longitudinal direction of the frame member for constituting the side body structure or the roof body structure is directed for a longitudinal direction of the car body of the railway vehicle.

One hollow shape extruded frame member 100 for constituting the structure body comprises substantially parallel two face plates 101 and 102, plural ribs 103 and 106A for connecting the face plates 101 and 102, and two protrusion portions 104a1 and 104a2 which protrude to a

thickness direction of the frame member 100.

Another hollow shape extruded frame member 110 for constituting the structure body comprises substantially parallel two face plates 111 and 112, plural ribs 113 and 116A for connecting the face plates 111 and 112, two protrusion portion 114b1 and 114b2 which protrude to a thickness direction of the frame member 110, and two protrusion chips 117b1 and 117b2 which protrude direction for from the rib 116A at an end portion to the frame member 110.

The plural ribs 103 of the frame member 100 are provided along to a width direction of the frame member 100. The rib 103 of the frame member 100 is provided to incline against to the face plates 101 and 102. The rib 106A of the frame member 100 is provided orthogonal to the face plates 101 and 102. A reference numeral 109 is a hollow portion of the frame member 100.

The plural ribs 113 of the frame member 110 are provided along to a width direction of the frame member 110. The rib 113 of the frame member 110 is provided to incline against to the face plates 111 and 112. The rib 116A of the frame member 110 is provided orthogonal to the face plates 111 and 112. A reference numeral 119 is a hollow portion of the frame member 110.

An end portion of the frame member 100, two vertical faces 121a1 and 121a2, two slope faces 122a1 and 122a2, a horizontal face 123a1 for connecting the vertical face

121a1 and the slope face 122a1, and a horizontal face 123a2 for connecting the vertical face 121a2 and the slope faces 122a2 are provided.

The vertical face 121a1 is provided at the end
5 portion side of the face plate 101 of the frame member 100, and the vertical face 121a2 is provided at the end portion side of the face plate 102 of the frame member 100. The horizontal face 123a1 is provided in parallel to the face plate 101 of the frame member 100, and the
10 horizontal face 123a2 is provided in parallel to the face plate 102 of the frame member 110.

The slope face 122a1 of the frame member 100 is provided in a face of a side of the face plate 101 of the protrusion chip 117a1, and the slope face 122a2 of the
15 frame member 100 is provided in a face of a side of the face plate 102 of a protrusion chip 117a2.

The slope face 122a1 of the frame member 100 is provided in a recessed portion which receives the protrusion chip 117b1 of the frame member 110. The slope
20 face 122a2 of the frame member 100 is provided in a recessed portion which receives the protrusion chip 117b2 of the frame member 110.

The slope face 122a1 is sloped from a position which enters to the thickness direction of the frame member 100 or from an end portion of the horizontal face 123a1. The
25 slope face 122a2 is sloped from a position which enters to the thickness direction of the frame member 100 or

from an end portion of the horizontal face 123a2.

The protrusion chip 117a1 is protruded to an outer portion (the frame member 100 side) of the width direction of the frame member 100 from the vertical face 121a1 of
 5 the frame member 100. The protrusion chip 117a2 is protruded to an outer portion (the frame member 100 side) of the width direction of the frame member 100 from the vertical face 121a2 of the frame member 100.

The protrusion portion 104a1 is provided to the end
 10 portion of the face plate 101 of the frame member 100, and the protrusion portion 104a2 is provided to the end portion of the face plate 102 of the frame member 100.

An end portion of the frame member 110, two vertical faces 121b1 and 121b2, two slope faces 122b1 and 122b2, a
 15 horizontal face 123b1 for connecting the vertical face 121b1 and the slope face 122b1, and a horizontal face 123b2 for connecting the vertical face 121b2 and the slope face 122b2 are provided.

The vertical face 121b1 is provided at the end
 20 portion side of the face plate 111 of the frame member 100, and the vertical face 121b2 is provided at the end portion side of the face plate 112 of the frame member 110. The horizontal face 123b1 is provided in parallel to the face plate 111 of the frame member 110, and the
 25 horizontal face 123b2 is provided in parallel to the face plate 112 of the frame member 110.

The slope face 122b1 of the frame member 110 is

provided in a face of a side of the face plate 111 of the protrusion chip 117b1, and the slope face 122b2 of the frame member 110 is provided in a face of a side of the face plate 112 of the protrusion chip 117b2.

5 The slope face 122b1 of the frame member 110 is provided in a recessed portion which receives the protrusion chip 117a1 of the frame member 100, and the slope face 122b2 of the frame member 110 is provided in a recessed portion which receives the protrusion chip 117a2
10 of the frame member 100.

 The slope face 122b1 is sloped from a position which enters to the thickness direction of the frame member 110 or from an end portion of the horizontal face 123b1, and the slope face 122b2 is sloped from a position which
15 enters to the thickness direction of the frame member 110 or from an end portion of the horizontal face 123b2.

 The protrusion chip 117b1 is protruded to an outer portion (the frame member 110 side) of the width direction of the frame member 110 from the vertical face 121b1 of
20 the frame member 110. The protrusion chip 117b2 is protruded to an outer portion (the frame member 110 side) of the width direction of the frame member 110 from the vertical face 121b2 of the frame member 110. The protrusion portions 114b1 is provided to the end portions
25 of the face plate 111 of the frame member 110. The protrusion portions 114b2 is provided to the end portions of the face plate 112 of the frame member 110.

The rib 116A of the frame member 110 is positioned at an extension line of a joining portion of the two frame members 100 and 110. The frame member 110 is supported by the rib 116A in which an axis center of a rotary body 20 is positioned at an extension line of a center of a plate thickness of the rib 116A of the frame member 110. Each of the vertical face 121b1 and the vertical face 121b2 of the frame member 110 is positioned a little at a center side of the width direction of the frame member 110 from a center of the plate thickness of the rib 116A. The vertical face 121b1 of the frame member 100 and the vertical face 121b2 of the frame member 110 are provided within a range of the extension line of the rib 116A. The plate thickness of the rib 116A of the frame member 110 is thicker than the plate thickness of the rib 106A of the frame member 100.

When the two frame members 100 and 110 are abutted, the vertical face 121a1 of the frame member 100 and the vertical face 121b1 of the frame member 110 are contacted together with. Further, when the two frame members 100 and 110 are abutted, the vertical face 121a2 of the frame member 100 and the vertical face 121b2 of the frame member 110 are contacted together with.

However, the above stated case is an ideal case, according to a dimension tolerance difference in the structure body, in many cases a gap is formed between the vertical face 121a1 of the frame member 100 and the

vertical face 121b1 of the frame member 110 and also a gap is formed between the vertical face 121a2 of the frame member 100 and the vertical face 121b2 of the frame member 110.

5 In Fig. 1 and Fig. 2, the slope face 122a1 of the frame member 100 and the slope face 122b1 of the frame member 110 are shown to contact together with and further the slope face 122a2 of the frame member 100 and the slope face 122b2 of the frame member 110 are shown to contact
10 together with, but in many cases there is a gap.

When the two frame members 100 and 110 are assembled, the faces of the outer faces of the two face plates 101 and 102 of the frame member 100 and the outer faces of the two face plates 111 and 112 of the frame member 110
15 are formed with the same faces. Namely, the slope faces 122a1 and 122b2 of the frame member 100 are recessed but the slope faces 122b1 and 122b2 of the frame member 110 are arisen. Accordingly, the two frame members 100 and 110 can be assembled easily.

20 Between a rear face of the face plate 111 which is positioned at the hollow portion 119 of the frame member 110 and the rib 116A of the frame member 110 is connected according to a circular arc 131b1 which is protruded to a side of the hollow portion 119 of the frame member 110 and
25 a recessed circular arc 132b1 and a recessed circular arc 133b1 of the frame member 110 at both ends.

Further, between a rear face of the face plate 112

which is positioned at the hollow portion 119 of the frame member 110 and the rib 116A of the frame member 110 is connected according to a circular arc 131b2 which is protruded to a side of the hollow portion 119 and a
5 recessed circular arc 132b2 and a recessed circular arc 133b2 at both ends.

The recessed portion of the circular arcs 132b1 and 133b1 of the frame member 110 is caused by protruding the circular arc 131b1 of the frame member 110. The recessed
10 portion of the circular arcs 132b2 and 133b2 of the frame member 110 is caused by protruding the circular arc 131b2 of the frame member 110.

The recessed portion of the circular arcs 132b1 and 133b2 of the frame member 110 means that the recessed
15 portion is recessed in comparison with a tangent line of a position of a central portion of the circular arc 131b1 of the frame member 110. The protrusion portion of the circular arc 131b1 of the frame member 110 can be called as a circular arc shape protrusion portion in the present
20 invention.

Also, the recessed portion of the circular arcs 132b2 and 133b2 of the frame member 110 means that the recessed
portion is recessed in comparison with a tangent line of a position of a central portion of the circular arc 131b2
25 of the frame member 110. The protrusion portion of the circular arc 131b2 of the frame member 110 can be called as a circular arc shape protrusion portion in the present

invention.

The position of the circular arc 131b1 of the frame member 110 is determined to ensure a predetermined distance along to a tip end of a small diameter portion 5 21 of the rotary body 20 when the rotary body 20 is inserted to a predetermined position. A center position of the circular arc 131b1 of the frame member 110 is determined that a position of a corner portion of the small diameter portion 21 of the rotary body 20 which has 10 inserted to the above predetermined position forms a standard basis.

Since an insertion force of the rotary body 20 is supported by the rib 116A of the frame member 110, in the prior art the metal can be flown out easily to an outer 15 portion from a surrounding portion of this rib 116A.

Accordingly, the thickness of the above stated surrounding portion of this rib 116A of the frame member 110 is made thick. According to the experimentation by the inventors of the present invention, a distance from the 20 corner portion of the small diameter portion 21 of the rotary body 20 to the circular arc 131b1 of the frame member 110 is 5 mm degree, for example.

As a result, in the prior art, the metal is flown out easily from the gap formed between the slope face 122a1 25 of the frame member 100 and the slope face 122b1 of the frame member 110 and also the metal is flown out easily from the gap formed between the protrusion chip 117b1 of

the frame member 110 and the rib 106A of the frame member 100.

Herein, a dot line in Fig. 1 shows a connection line of the rib and the face plate according to the conventional
 5 technique of the prior art. In this example of the prior art, the connection line comprises a linear line at a central portion and circular arcs which are provided at both ends of the linear line. The above stated linear line at the central portion is a tangent line which
 10 contacts to a central portion of the circular arc 131b1 or the circular arc 131b2 of the frame member 110. As another example of the prior art, a whole connection line is formed to have a circular arc which is recessed to a side of a joining bead of the frame members 100 and 110.

15 Understood from the comparison the dot line of the connection line according to the prior art with the real line of the connection line according to the present invention, a cross-sectional area of the parts, which are the portion between the frame member 100 and the rib 106A
 20 and the portion between the frame member 110 and the rib 116A, can be made small according to by the employment of the present invention. As a result, according to the structure body of this embodiment according to the present invention, a light weight structure of the frame member
 25 for constituting the structure body can be attained.

In this embodiment according to the present invention, the recessed portions are formed at the both

ends of the circular arc 131b1 of the frame member 110 and also at the both ends of the circular arc 131b2 of the frame member 110. However, such a recessed portion can be provided only one end of the circular arc 131b1 of the frame member 110 or one end of the circular arc 131b2 of the frame member 110. At a side where the recessed portion is not provided, a liner line is connected to an end portion of the circular arc and further this end portion and a rib (or a face plate) are connected by another circular arc. However, in this latter case, the degree of the light weight structure of the frame member for constituting the structure body can be lowered.

A rear face of a tip end of the protrusion chip 117b1 of the frame member 110 is formed with a circular arc which goes thinner according to the tip end of the protrusion chip 117b1 of the frame member 110. Also, a rear face of a tip end of the protrusion chip 117b2 of the frame member 110 is formed with a circular arc which goes thinner according to the tip end of the protrusion chip 117b2 of the frame member 110. A circular arc 135b1 is provided on the face plate 111 of the frame member 110 and a circular arc 135b2 is provided on the face plate 112 of the frame member 110. The circular arc 135b1 is provided on the face plate 111 has the same radius of the circular arc 131b1 provided on the face plate 111 and the circular arc 135b2 provided on the face plate 112 has the same radius of the circular arc 131b2 provided on the

face plate 112.

The rotary body 20 for carrying out the friction stir welding use provides the small diameter portion 21 at a tip end of a large diameter round rod portion 20a. A boundary face portion 20b formed between the large diameter portion 20a and the small diameter portion 21 of the rotary body 20 has a circular arc shape which is recessed to a side of the large diameter portion 20a. The small diameter portion 21 of the rotary body 20 is a screw member.

The friction stir welding for joining the two frame members 100 and 110 is carried out by rotating the rotary body 20 and inserting the rotary body 20 to the two frame members 100 and 110 and moving it along to a joining line of the two frame members 100 and 110. An axis center of the rotary body 20 is that the side of the large diameter portion 20a of the rotary body 20 is inclined against the moving direction of the rotary body 20.

Accordingly, a rear end of the boundary face portion 20b of the rotary body 20 is inserted to the two frame members 100 and 110, however a front end of the boundary face portion 20b of the rotary body 20 is positioned at an outer side (an upper portion) from an outer face (in Fig. 1, in a case of the upper side protrusion portion 104a1 of the frame member 100 and the upper side protrusion portion 114b1 of the frame member 110) of an upper portion of an apex of the protrusion portion 104a1 of the frame

member 100 and an upper portion of an apex of the protrusion portion 114b1 of the frame member 110.

The rear end of the boundary face portion 20b of the rotary body 20 is positioned between the protrusion
5 portion 104a1 of the frame member 100 and the protrusion portion 114b1 of the frame member 110 and the outer faces of the two face plates 101 and 102 of the frame member 100 and the two face plates 111 and 112 of the frame member 110. The above stated "rear end" term and "front end"
10 term in the present invention are defined from the moving direction of the rotary body 20 as a standard basis.

Fig. 1 shows a condition where the rotary body 20 is inserted to a predetermined position of the two frame members 100 and 110 for constituting the structure body.
15 In Fig. 1, a part of the tip end of the small diameter portion 21 of the rotary body 20 is omitted. The tip end of the small diameter portion 21 of the rotary body 20 is positioned at a vicinity of the horizontal face 123a1 of the frame member 100 and the horizontal face 123b1 of the
20 frame member 110.

During the friction stir welding process, the two frame members 100 and 110 are pressed and are restrained to a bed (not shown in figure) by means of a vise of an apparatus (not shown in figure) under from the upper
25 portion. To contact the slope face 122a1 of the frame member 100 and the slope face 122b1 of the frame member 110 together with, the frame member 100 is pressed

directing for (in Fig. 1, a right and left direction) the opposed frame member 110.

During the friction stir welding process, there is a roller (not shown in figure) which move accompany with
 5 the move of the friction stir welding use rotary body 20. The roller presses down the right and the left portion of the protrusion portion 104a1 of the frame member 100 and the protrusion portion 114b1 of the frame member 110 or the upper portion of the protrusion portion 104a1 of the
 10 frame member 100 and the upper portion of the protrusion 114b1 of the frame member 110.

Each of the friction stir welding for the upper and lower portions of the frame member 100 and the upper and lower portions of the frame member 110 is carried out as
 15 following. Namely, after one side face of the two frame members 100 and 110 has joined by the friction stir welding, turning over the two frame members 100 and 110 or by arranging the two rotary bodies 20 and 20, a simultaneous friction stir welding manner is carried out.

20 A number of the frame members 110 and 110 which are mounted on the bed is two or more than two. After the friction stir welding process, the structure body obtained by this friction stir welding process is carried out to join further according to the friction stir welding or a
 25 common welding and the car body of the railway vehicle is obtained.

To an abutted face of the frame members 100 and 110

the slope faces 122a1 and 122a2 of the frame member 100 and the slope faces 122b1 and 122b2 of the frame member 110 are provided. As a result, the two frame members 100 and 110 can be assembled and further a slip-off to the up and down directions between the two frame members 100 and 110 can be prevented.

Further, when the two slope face 122a1 of the frame member 100 and the slope face 122b1 of the frame member 110 and the slope face 122a2 of the frame member 100 and the slope face 122b2 of the frame member 110 are contacted, in comparison with a non-contact condition case, the flow-out of the metal in the above stated case can be prevented from these portions.

A gap formed between the vertical face 121a1 of the frame member 100 and the vertical face 121b1 of the frame member 110 is closed and further a gap formed between the vertical face 121a2 of the frame member 100 and the vertical face 121b2 of the frame member 110 is closed by the move of the metal from the protrusion portions 104a1 and 104a2 of the frame member 100 and the protrusion portions 114b1 and 114b2 of the frame member 110.

The vertical faces 121a1 and 121a2 of the frame member 100 and the vertical faces 121b1 and 121b2 of the frame member 110 may provide to incline, however it is necessary to make large the move amount of the metal from the protrusion portions 104a1 and 104a2 of the frame member 100 and the protrusion portions 114b1 and 114b2 of the

frame member 110.

To the end portions of the protrusion chip 117b1 and 117b2 of the frame member 110 and the two slope faces 122a1 and 122a2 of the frame member 100 and the two slope
 5 faces 122b1 and 122b2 of the frame member 110 are provided. However it can provide the faces which are in parallel to the face plates 101 and 102 of the frame member 100 and to the face plates 111 and 112 of the frame member 110.

10 After the friction stir welding process, demands to occasions, the protrusion faces 104a1 of the frame member 100 and the protrusion face 114b1 of the frame member 110 may cut off to have the same face to form the outer face of the face plate 101 of the frame member 100 and the outer
 15 face of the face plate 111 of the frame member 110. Also, the protrusion face 104a2 of the frame member 100 and the protrusion face 114b2 of the frame member 110 may cut off to have the same face to form the outer face of the face plates 102 of the frame member 100 and the outer face of
 20 the face plate 112 of the frame member 110.

In a case where it is employed as the car body of the railway vehicle, as shown in Fig. 2, the protrusion face 104a1 of the frame member 100 and the protrusion face 104b1 of the frame member 110 which from the outer
 25 face of the car body of the railway vehicle are cut off. Also the protrusion face 104a2 of the frame member 100 and the protrusion face 104b2 of the frame member 110

which from the outer face of the car body of the railway vehicle are cut off. Reference numeral 30a and 30b shown in Fig. 2 denote a joining bead of the two frame members 100 and 110, respectively.

5 A structure body and a hollow shape extruded frame member of another embodiment according to the present invention will be explained referring to Fig. 3. Fig. 3 is a partially enlarged longitudinal cross-sectional view showing a structure body having a joint member for use in
10 a friction stir welding of another embodiment according to the present invention.

In the structure body shown in Fig. 3, a joining portion is positioned at an intermediate portion between a rib 106B of the frame member 100 and a rib 116B of the
15 frame member 110. Between the rib 116B and the face plate 111 of the frame member 110 is connected by one circular arc shape protrusion chip 131b1 and also between the rib 116B and the face plate 112 of the frame member 110 is connected by another circular arc shape protrusion chip
20 131b2.

A root of the rib 116B and the protrusion chip 117b1 of the frame member 110 are connected by a circular arc 141b1 which is raised to a side of the face plate 111 of the frame member 110 and two circular arcs 142b1 and 143b1
25 which are recessed directing for a side of the face plate 111 of the frame member 110. A root of the rib 116B and the protrusion chip 117b2 of the frame member 110 are

connected by a circular arc 141b2 which is raised to a side of the face plate 112 of the frame member 110 and two circular arcs 142b2 and 143b2 which are recessed directing for a side of the face plate 112 of the frame member 110.

Between the rib 106B and the face plate 101 of the frame member 100 is connected by a circular arc 145a1 which is raised to a side of the hollow portion 109 and two circular arcs 146a1 and 147a1 which are recessed to a side of the vertical face 121a1 of the face plate 101 of the frame member 100. Further, between the rib 106B and the face plate 102 of the frame member 100 is connected by a circular arc 145a2 which is raised to a side of the hollow portion 109 and two circular arcs 146a2 and 147a2 which are recessed to a side of the vertical face 121a2 of the face plate 102 of the frame member 100.

A dot line shown in Fig. 3 is a connection line according to the conventional technique shown in the prior art and a whole connection line according to the conventional technique forms a circular arc. The connection line according to the conventional technique shown in the dot line against the circular arcs 141b1, 142b1 and 143b1 of the protrusion chip 117b1 is omitted. Also the connection line according to the conventional technique shown in the dot line against the circular arcs 141b2, 142b2 and 143b2 of the protrusion chip 117b2 is omitted. Further, the above stated two connection lines

according to the conventional technique in the prior art shown in the dot lines at the side of the face plates 101 and 102 of the frame member 100 are omitted.

Each of the dimensions of the circular arcs 131b1, 141b1 of the face plate 111 of the frame member 110 and the circular arc 145a1 of the face plate 101 of the frame member 100 is the same. Namely, each of the radius of the circular arcs 131b1, 141b1 of the frame member 110 and the circular arc 145a1 of the frame member 100 has an equal size. Further, each of the dimensions of the circular arcs 131b2 and 141b2 of the face plate 112 of the frame member 110 and the circular arc 145a2 of the face plate 102 of the frame member 100 is the same. Namely, each of the radius of the circular arcs 131b2 and 141b2 of the frame member 110 and the circular arc 145a2 of the frame member 100 has an equal size.

According to the structure body and the hollow shape extruded frame member of this embodiment according to the present invention, since the load during the friction stir welding process is burdened according to the two ribs 106B and 116B, the vicinities of the two ribs 106B and 116B are formed thick. The vicinities of the two ribs 106B and 116B are the connection parts of the face plates 101 and 102 of the frame member 100 and the face plates 111 and 112 of the frame member 110.

Further, according to the structure body and the hollow shape extruded frame member of this embodiment

according to the present invention, a total value of the plates thicknesses of the two ribs 106B and 116B can be made smaller than the structure body of the former embodiment according to the present invention shown in
5 Fig. 1 and Fig. 2.

As a result, according to the structure body and the hollow shape extruded frame member of this embodiment according to the present invention, the light weight structure in the structure body and the light weight
10 structure in the hollow shape extruded frame member can be obtained.

Even the plate thickness of the rib 116B of the frame member 110 is made thicker than the plate thickness of the rib 116A of the frame member 100 shown in Fig. 1 and Fig.
15 2, the plate thickness of the rib 106B of the frame member 110 and the plate thickness of the rib 116B of the frame member 110 can be the same thickness.

Further, in each of between the rib 106B and the face plates 111 and 112 of the frame member 110, between the
20 rib 106B and the protrusion chip 117b1 of the plate face 111 of the frame member 110 and the protrusion chip 117b2 of the plate face 112 of the frame member 110 and further between the rib 106B and the face plates 101 and 102 of the frame member 100, the light weight structure in the
25 structure body and the light weight structure in the hollow shape extruded frame member can be obtained.

Since the recessed portions 132b1 and 133b1 formed

between the circular arc 131b1 and the rib 116B of the face plate 111 of the frame member 110 are small and also the recessed portions 132b2 and 133b2 formed between the circular arc 131b2 and the rib 116B of the face plate 112 of the frame member 110 are small, it can employ a case to which no recessed portion is provided in the frame member 110. For example, a tangent line is provided to an end portion at a side of the circular arc 131b1 and the rib 116B and this tangent line and the rib 116B are connected by a circular arc. When the protrusion chip 117b1 or 117b2 at a side of the face plate 112 of the frame member 110 is provided at a side of the rib 106B, the similar effect can be obtained.

Further, without of the provisions of the slope face 122a1 of the face plate 101 of the frame member 100 and the slope face 122a2 of the face plate 102 of the frame member 100, the horizontal face can be employed. Further, without of the provisions of the slope face 122b1 of the face plate 111 of the frame member 110 and the slope face 122b2 of the face plate 112 of the frame member 110, a horizontal face can be employed.

When the two frame members 100 and 110 are assembled, the slope face 122a1 of the face plate 101 of the frame member 100 and the slope face 122b1 of the face plate 111 of the frame member 110 are contacted together with and the gap is provided between the vertical face 121a1 of the face plate 101 of the frame member 100 and the

vertical face 121b1 of the face plate 111 of the frame member 110.

Further, when the two frame members 100 and 110 are assembled, the slope face 122a2 of the face plate 102 of the frame member 100 and the slope face 122b2 of the face plate 112 of the frame member 110 are contacted together with and the gap is provided between the vertical face 121a2 of the face plate 101 of the frame member 100 and the vertical face 121b2 of the face plate 112 of the frame member 110. For example, an interval between the recessed portion slope faces 122a1 and 122a2 of the frame member 100 is provided to be smaller than an interval between the arisen portion slope faces 122b1 and 122b2 of the frame member 110.

As a result, according to the structure body and the hollow shape extruded frame member of this embodiment according to the present invention, the flow-out of the metal from the slope face 122a1 of the frame member 100 and the slope shape 122b1 of the frame member 110 can be prevented and further the flow-out of the metal from the slope face 122a2 of the frame member 100 and the slope face 122b2 of the frame member 110 can be prevented.

The technical range according to the present invention is not limited to the terms stated in each claim of the claims what is claimed item or the terms stated in the means for solving the problems item but refers to the range in which the ordinary man belonged to

this technical field can be replaced easily.

Although, the present invention has been described and illustrated in detail, it is be clearly understood that the same is by way of illustration and example, and
5 it is not to be taken by way of limitation. The spirit and scope of the present invention are not limited only by the terms of the appended claims.

According to the structure body and the hollow shape extruded frame member of the present invention, in the
10 case where the friction stir welding manner is applied, the structure body and the hollow shape extruded frame member can be made with the light weight structure.

Throughout this specification and the claims which follow, unless the context requires otherwise, the word "comprise", and variations such as "comprises" and "comprising", will be understood to imply the inclusion of a stated integer or step or group of integers or steps but not the exclusion of any other integer or step or group of integers or steps.

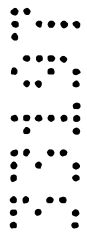

The claims defining the invention are as follows:

1. A structure body characterized in that:

5 a first member having substantially parallel two first face plates and plural first ribs for connecting said two first face plates; and

a second member having substantially parallel two second face plates and plural second ribs for connecting said two second face plates;

10 said first member and said second member are joined according to two joining beads;

one of said two joining beads joins one of said two first face plates of said first member and said one of said two joining beads joins one of said two second face plates of said second member;

15 another of said two joining beads joins another of said two first face plates of said first member and said another of said two joining beads joins another of said two second face plates of said second member; and

20 a first connection line between said first rib of said first member at a vicinity of said one of said two joining beads and a rear face of said one of said two first face plates of said first member at a position of a first hollow portion of said first member is a first circular arc

25 shape protrusion arc which is protruded to a side of said first hollow portion of said first member.

2. A structure body according to claim 1, characterized in that

both end portions of said first circular arc shape protrusion arc are recessed directing for a side of said one of said two joining beads.

3. A structure body characterized in that:

a first member having substantially parallel two first face plates and plural first ribs for connecting said two first face plates; and

a second member having substantially parallel two second face plates and plural second ribs for connecting said two second face plates;

said first member and said second member are joined according to two joining beads;

one of said two joining beads joins one of said two first face plates of said first member and said one of said two joining beads joins one of said two second face plates of said second member;

another of said two joining beads joins another of said two first face plates of said first member and said another of said two joining beads joins another of said two second face plates of said second member;

a first connection line between said first rib of said first member at a vicinity of said one of said two joining beads and a rear face of said one of said two first face plates of said first member at a position of a first

hollow portion of said first member is a first circular arc shape protrusion arc which is protruded to a side of said first hollow portion of said first member; and

5 a second connection line between said first rib of said first member at a vicinity of said another of said two joining beads and a rear face of said one of said two first face plates of said first member at a position of said first hollow portion of said first member is a second circular arc shape protrusion arc which is
10 protruded to said side of said first hollow portion of said first member.

4. A structure body according to claim 3, characterized in that

15 both end portions of said first circular arc shape protrusion arc are recessed directing for a side of said one of said two joining beads; and

both end portions of said second circular arc shape protrusion arc are recessed directing for a side of said
20 another of said two joining beads.

5. A structure body characterized in that:

a first member having substantially parallel two first face plates and plural first ribs for connecting
25 said two first face plates; and

a second member having substantially parallel two second face plates and plural second ribs for connecting

said two second face plates;

said first member and said second member are joined according to two joining beads;

one of said two joining beds joins one of said two face
5 plates of said first member and said one of said two joining
beads joins one of said two second face plates of said second
member;

another of said two joining beads joins another of said two
first face plates of said first member and said another of said
10 two joining beads joins another of said two second face plates
of said second member;

said two joining beads are positioned respectively at an
intermediate portion between said first rib of said first member
and said second rib of said second member;

15 one of said two second face plates of said second member is
overlapped to a protrusion chip which is protruded directing for
from said first rib at a vicinity of said one of said two
joining beads to said second member;

a first connection line between said first rib at the
20 vicinity of said one of said two joining beads and a rear face
of one of said first face plate at a position of a first hollow
portion of said two first members is a first circular arc shape
protrusion arc which is protruded to a side of said first hollow
portion of said first member; and

25 a second connection line between said second rib at the
vicinity of said one of said two joining beads and a rear face
of one of said two second face plates at a position of a second
hollow portion of said second member is a third circular arc
shape protrusion arc which is protruded to a side of said second
30 hollow portion of said second member.

6. A structure body according to claim 5, characterized in
that

both end portions of said first circular arc shape



protrusion arc is recessed directing for to a side of one of said two joining beads; and

both end portions of said second circular arc shape protrusion arc is recessed directing for to a side of said one 5 of said two joining beads.

7. A structure body according to claim 5, characterized in that

between said protrusion chip and said first rib having said 10 protrusion chip is connected according to a second circular arc shape arc protrusion arc which is protruded directing for to a side of another said first face plate of said first member.

8. A structure body according to claim 7, characterized in 15 that

both end portions of said first circular arc shape

5
10
15

20
25
30
35



protrusion arc of said protrusion chip is recessed directing for said both end portions of said protrusion chip.

5 9. A structure body characterized in that:

a first member having substantially parallel two first face plates and plural first ribs for connecting said two first face plates; and

10 a second member having substantially parallel two second face plates and plural second ribs for connecting said two second face plates;

said first member and said second member are joined according to two joining beads;

15 one of said two joining beads joins one of said two first face plates of said first member and said one of said two joining beads joins one of said two second face plates of said second member;

20 another of said two joining beads joins another of said two first face plates of said first member and said another of said two joining beads joins another of said two second face plates of said second member;

25 a first connection line between said first rib of said first member at a vicinity of said one of said two joining beads and a rear face of one of said two first face plates of said first member at a position of a first hollow portion of said first member is a first circular arc shape protrusion arc which is protruded to a side of said

first hollow portion of said first member;

a second connection line between said second rib of said second member at a vicinity of said one of said two joining beads and a rear face of one of said two second face plates of 5 said second member at a position of a second hollow portion of said second member is a second circular arc shape protrusion arc which is protruded to said side of said second hollow portion of said second member;

a third connection line between said first rib of said 10 first member at a vicinity of said another of said two joining beads and a rear face of another of said two first face plates of said first member at a position of said first hollow portion of said first member is a third circular arc shape protrusion arc which is protruded to said side of said first hollow portion 15 of said first member; and

a fourth connection line between said second rib of said second member at a vicinity of said another of said two joining beads and a rear face of another of said two second face plates of said second member at a position of said second hollow 20 portion of said second member is a fourth circular arc shape protrusion arc which is protruded to said side of said second hollow portion of said second member.



10. In a hollow shape extruded frame member having substantially parallel two face plates and plural ribs for connecting said two face plates, characterized in that

a connection line formed between said rib of at

5 least one end portion of said hollow shape extruded frame member and a rear face of said face plate at a position of a hollow portion of said hollow shape extruded frame member is a circular arc shape protrusion arc which protrudes to a side of said hollow portion of said hollow

10 shape extruded frame member.

11. A hollow shape extruded frame member according to claim 10, characterized in that

both end portions of said circular arc shape

15 protrusion arc are recessed directing for to a side of said end portion of said hollow shape extruded frame member.

12. A hollow shape extruded frame member according to

20 claim 11, characterized in that

said hollow shape extruded frame member comprises a protrusion chip which is protruded from said rib of said end portion to a side of said end portion;

said protrusion chip is arranged at said rib having

25 said circular arc shape protrusion arc and at a side at least one of said face plate; and

a connection line formed between said protrusion

chip and said rib is a circular arc one which protrudes to a side of another said face plate.

13. A hollow shape extruded frame member according to
5 claim 12, characterized in that

both end portions of said circular arc shape protrusion arc of said protrusion chip are recessed directing for a side of another end portion of said rib.

10 14. A hollow shape extruded frame member according to claim 11, characterized in that

said hollow shape extruded frame member comprises a protrusion chip which is protruded from said rib of said end portion to a side of said end portion;

15 said protrusion chip is arranged at said rib of said end portion and at a side of at least one another of said face plate; and

at a tip end of said protrusion chip a face at an opposite side to said face plate is a circular arc shape
20 protrusion arc in which a thickness becomes thinner according to a tip end; and

a connection line formed between said protrusion chip and said rib is a circular arc shape protrusion arc which is protruded to a side of another said face plate.

14. A body substantially as hereinbefore described with reference to the drawings and/or Examples.

15. A frame member substantially as hereinbefore described with 5 reference to the drawings and/or Examples.

DATED this 14th day of March, 2000

10

HITACHI, LTD.

By its Patent Attorneys

Davies Collison Cave

5
12

8

9

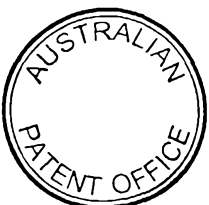

FIG. 1

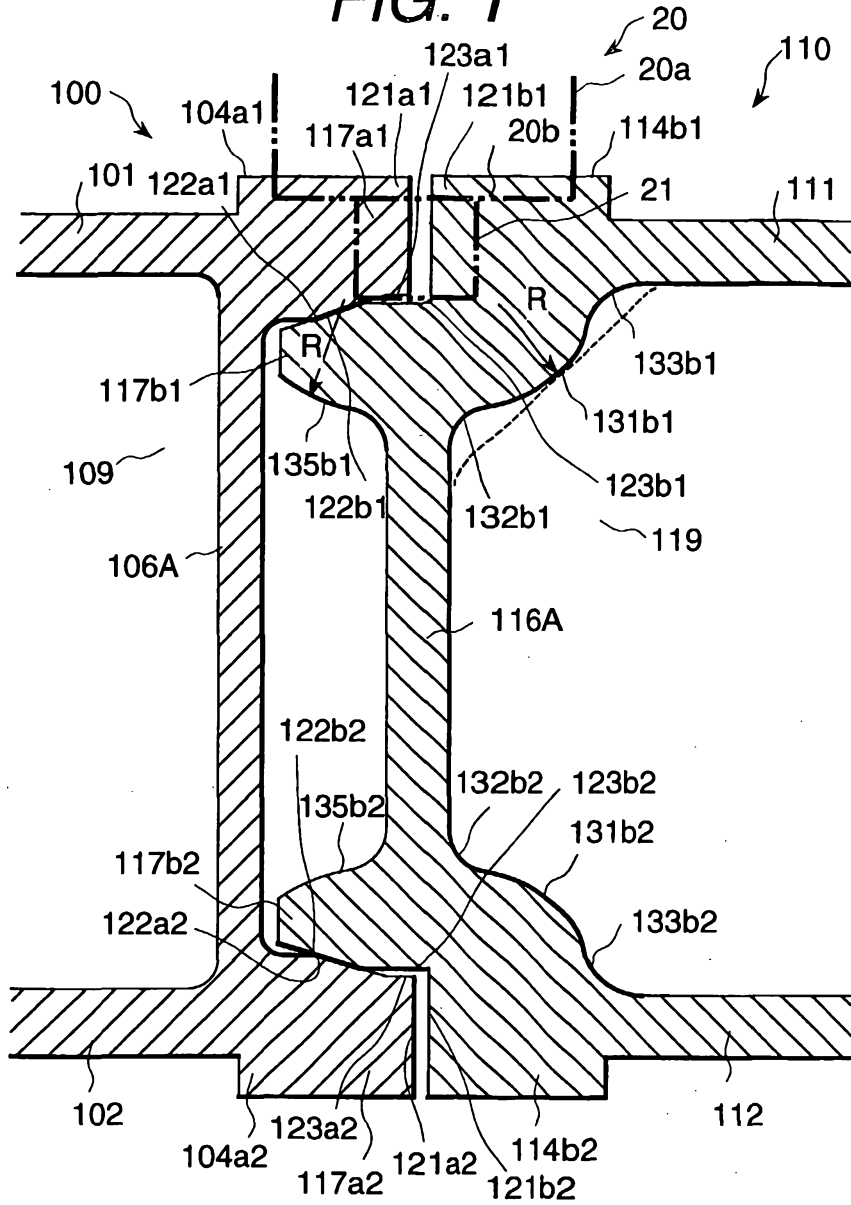

FIG. 2

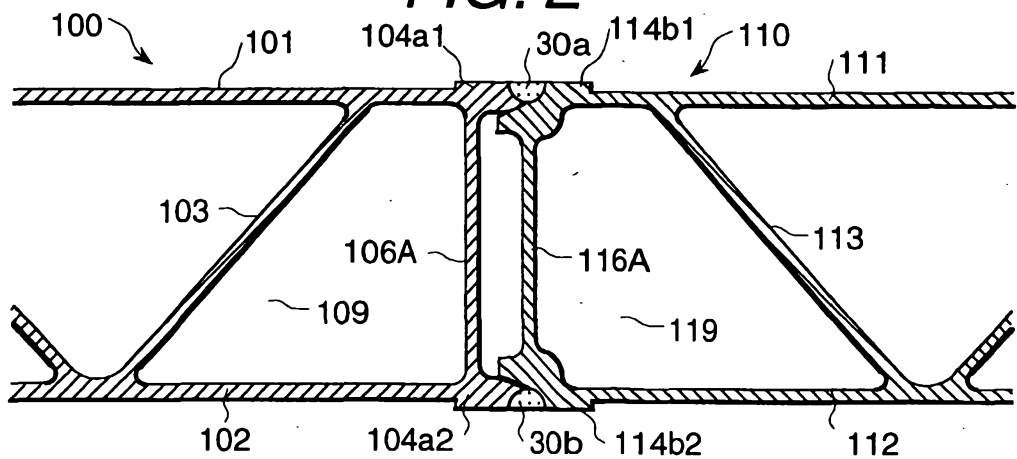

FIG. 3

