



US 20050055874A1

(19) **United States**

(12) **Patent Application Publication**
Bekemeyer

(10) **Pub. No.: US 2005/0055874 A1**

(43) **Pub. Date: Mar. 17, 2005**

(54) **METHOD AND SYSTEM FOR BLENDING AND DISPENSING FUELS**

(52) **U.S. Cl. 44/629**

(76) **Inventor: Neil Bekemeyer, Washington, KS (US)**

(57) **ABSTRACT**

Correspondence Address:
THOMAS B. LUEBBERING
HOVEY WILLIAMS LLP
Suite 400
2405 Grand
Kansas City, MO 64108 (US)

A method and system for blending and dispensing fuels that makes it easier for a retail filling station (10) to provide blended fuels to its customers and that more effectively encourages customers to purchase the blended fuels. Gasoline and additives such as ethanol are received and stored in separate tanks (12-18) at the filling station. Customers of the filling station are then allowed to select the amount of additive, if any, to add to their gasoline. Once a selection has been made, a proportioner (40) blends the selected amount of additive with gasoline at the time of purchase and then dispenses the blended fuel to the customer.

(21) **Appl. No.: 10/663,542**

(22) **Filed: Sep. 16, 2003**

Publication Classification

(51) **Int. Cl.⁷ C10L 5/00**

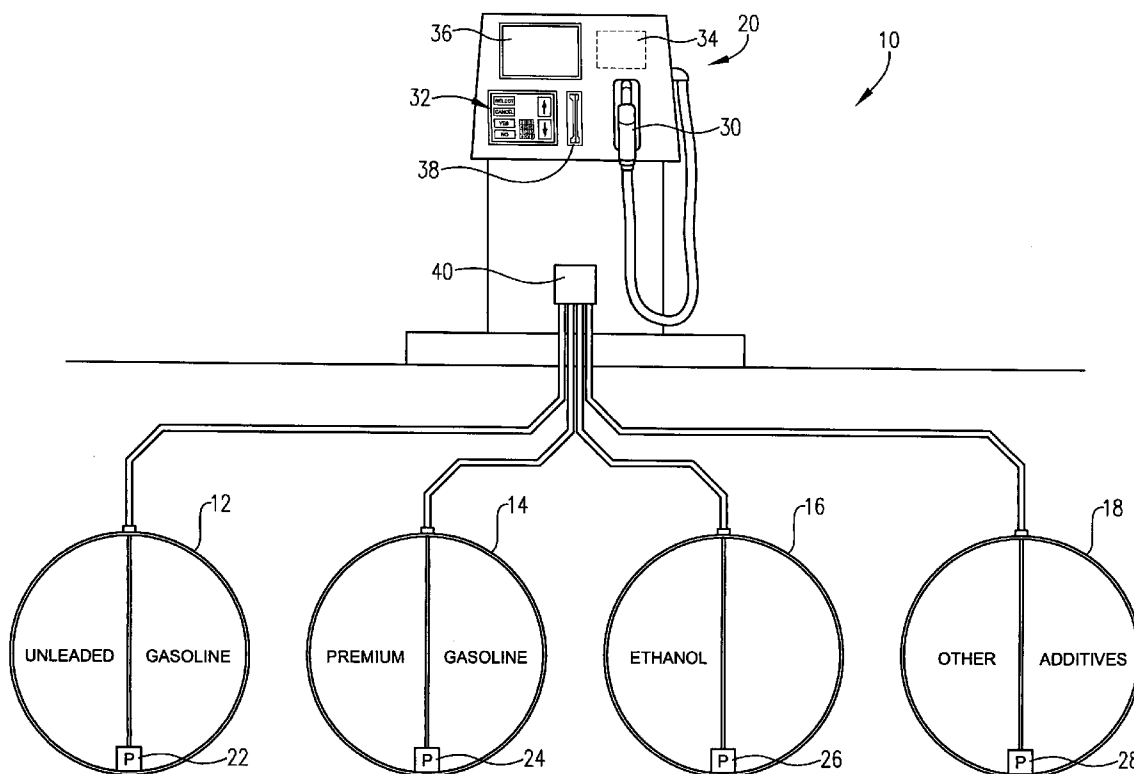

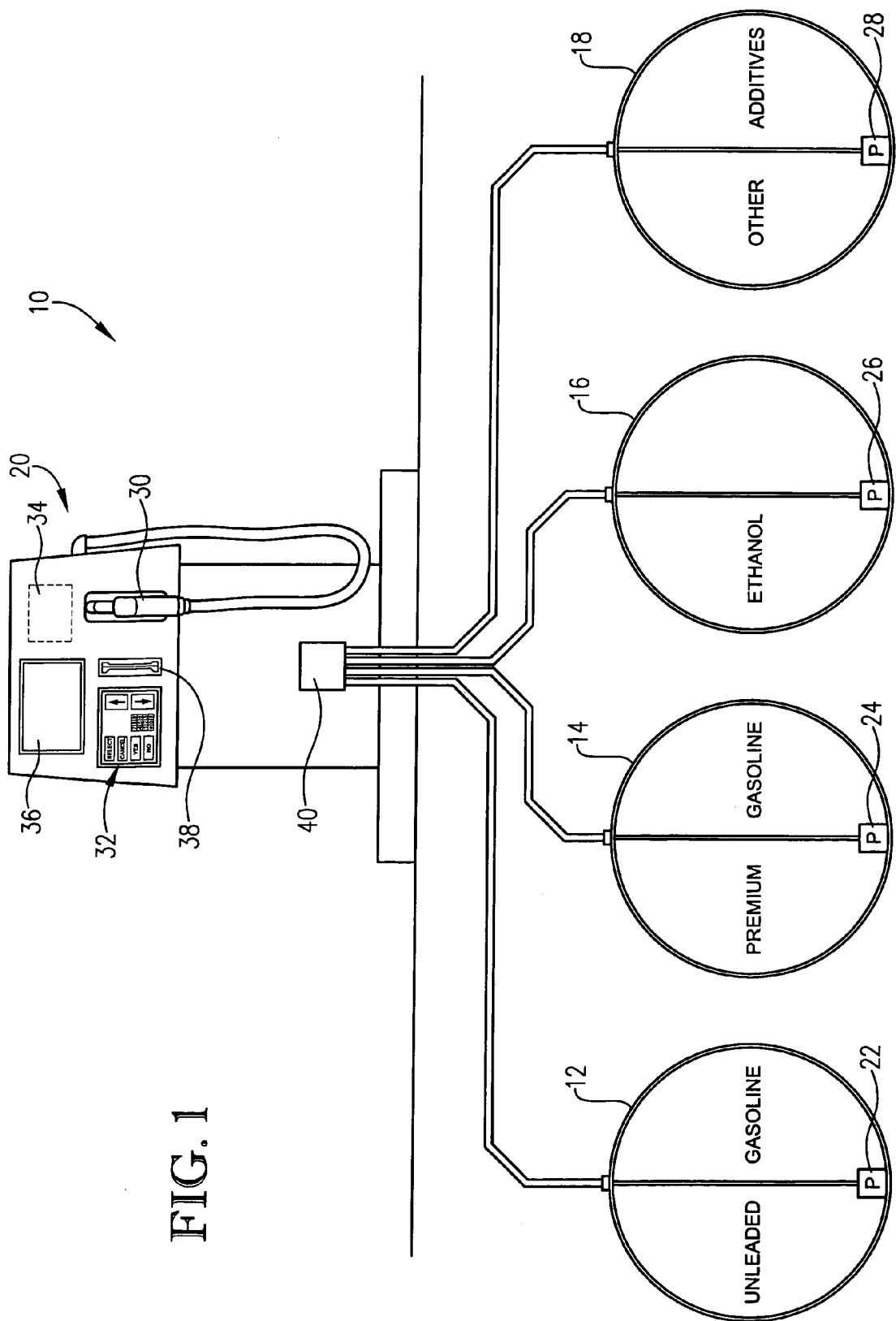

FIG. 1

FIG. 2a

PLEASE SELECT:
- REGULAR UNLEADED
- UNLEADED
- PREMIUM UNLEADED
THEN PRESS "SELECT" BUTTON

FIG. 2b

PLEASE SELECT ADDITIVE:
- NONE
- ETHANOL
- OCTANE
THEN PRESS "SELECT" BUTTON

FIG. 2c

PLEASE SELECT PERCENT
OF ADDITIVE WITH ↑↓
THEN PRESS "SELECT" BUTTON

FIG. 2d

YOUR SELECTION IS:

5% ETHANOL

95% PREMIUM UNLEADED

COST - \$1.12/gal.

PRESS "SELECT" TO CONFIRM

FIG. 2e

OPTIONS:

10% ETHANOL - \$1.06/gal.

20% ETHANOL - \$1.00/gal.

20% ETHANOL W/ CLEANER - \$1.12/gal.

METHOD AND SYSTEM FOR BLENDING AND DISPENSING FUELS

BACKGROUND OF THE INVENTION

[0001] 1. Field of the Invention

[0002] The present invention relates to methods and systems for blending and dispensing fuels. More particularly, the invention relates to a method and system for blending ethanol with gasoline at a retail filling station so as to better encourage the use of blended ethanol fuels.

[0003] 2. Description of the Prior Art

[0004] Biomass fuels or biofuels are organic substances made from crops, trees, or even landfill gases that can be broken down into chemical building blocks and used as a energy sources to produce heat, fuel, or electricity. Ethanol, the best known of the biomass fuels, is distilled from corn and blended with conventional gasoline as a fuel source for combustion engines such as those found in automobiles. The use of ethanol as a gasoline additive reduces our nation's dependence on imported oil and provides an important new market for farmers and other grain producers.

[0005] The United States government therefore encourages the use of ethanol by providing tax incentives. Current tax incentives include: 1) an excise tax exemption in which the federal excise tax on gasoline is reduced for ethanol blended fuel, and 2) a blenders' income tax credit in which blenders are given an income tax credit for each gallon of gasoline blended with ethanol. Although these tax incentives encourage the use of ethanol blended fuels, they are not completely effective.

[0006] Currently, gasoline and ethanol are shipped to a fuel terminal (commonly referred to as a "rack") where trucks supplying retail filling stations are loaded. Ethanol is blended with gasoline at the rack, and the blended fuel is then shipped to retail filling stations and stored in tanks until it is dispensed to customers. This arrangement, and the distribution of the tax incentives mentioned above, limit the use of ethanol for several reasons. First, the ethanol tax incentives are provided to the blenders, which are typically owned by petroleum companies. Petroleum companies do not want to reduce the demand for their conventional gasolines by offering cheaper ethanol blends and therefore rarely pass on the tax incentives to customers. Therefore, the cost to purchase ethanol blended fuels is currently about the same as the cost to purchase unblended gasoline, providing no incentive for customers to purchase the ethanol blended fuels.

[0007] Second, because ethanol and gasoline are currently blended before delivery to filling stations, the filling stations must provide dedicated storage tanks for the blended fuel. This is a problem because filling stations typically only have space for a few tanks and cannot easily add more. Moreover, pre-mixing the blended fuel typically limits customers to one blend only. If a filling station wants to offer more than one blend (e.g. a 10% ethanol blend and a 7% blend), multiple dedicated tanks are required. Most filling stations do not have room for extra fuel tanks and therefore provide only one blend of ethanol fuel or none at all.

[0008] Accordingly, there is a need for an improved method and system for blending and dispensing fuels that overcomes the limitations of the prior art.

SUMMARY OF THE INVENTION

[0009] The present invention solves the above-described problems and provides a distinct advance in the art of fuel blending and dispensing methods. More particularly, the present invention provides a method and system for blending and dispensing fuels that: 1) makes it easier for retail filling stations to provide blended fuels to their customers; and 2) more effectively encourages customers to purchase the blended fuels by providing more fuel choices and price incentives.

[0010] In one implementation of the invention, a retail filling station receives and stores gasoline in one or more tanks and an unblended fuel additive such as ethanol in a separate tank. The station will typically include several gasoline tanks for different types of gasoline such as unleaded, regular, and premium. The station may also include multiple tanks for additives, such as one for ethanol and another for an engine cleaner additive.

[0011] One or more pump assemblies are operatively coupled with the tanks in a conventional manner so as to pump fuels or additives therefrom. In accordance with one aspect of the present invention, each pump assembly is equipped with a proportioner or other mixing device which mixes or blends a selected amount of ethanol or other additive with gasoline as it is dispensed to a customer. Thus, a retail filling station utilizing the present invention receives and stores unblended ethanol and gasoline and then blends a selected amount of the ethanol with gasoline as it is purchased. In preferred forms, the customer is allowed to select the amount of ethanol to blend with the gasoline. For example, the customer may select a 10% blended fuel containing 10% ethanol and 90% gasoline.

[0012] The pump assembly then calculates or looks-up the cost of the blended fuel based on the amount of ethanol selected. Because use of ethanol is subject to the tax incentives described above, the filling station may provide a greater discount for higher percentage ethanol blends, thus encouraging customers to add more ethanol to their fuel. The filling station may pass on the entire tax incentives to customers or may retain a portion of it to offset the costs of storing the ethanol.

[0013] The pump assembly may also store the percentage of ethanol selected by a customer along with some identifier for the customer such as the customer's credit card. This percentage may then be displayed to the customer at subsequent visits to the filling station so that the customer may automatically purchase the same blended fuel every time. The pump assembly may also automatically calculate and display the cost of various blends of fuel so that customers may make informed choices as to the amount of ethanol they select.

[0014] The present invention provides numerous advantages. For example, by receiving and storing both unblended gasoline and unblended ethanol and/or other additives at a filling station and then blending the fuels and additives as they are purchased, customers are allowed to select the exact amount of ethanol or other additive they wish to have blended in their gasoline. Moreover, even though any amount of additive can be selected, only one storage tank is required for each additive. This allows filling stations to provide customers with more fuel choices without purchasing, installing, and maintaining a separate storage tank for each blend of fuel.

[0015] Additionally, by blending the ethanol and gasoline at the point of purchase, the station can obtain the ethanol tax incentives and pass on the savings to customers. This encourages filling stations to offer ethanol and encourages customers to purchase more ethanol blended fuel, thus reducing our nation's dependence on imported oil and providing more revenue to farmers.

[0016] These and other important aspects of the present invention are described more fully in the detailed description below.

BRIEF DESCRIPTION OF THE DRAWING FIGURES

[0017] A preferred embodiment of the present invention is described in detail below with reference to the attached drawing figures, wherein:

[0018] FIG. 1 is a schematic diagram illustrating certain components of a retail filling station which may be used to implement the present invention;

[0019] FIG. 2a depicts a screen display of a display on the pumping assembly shown in FIG. 1.

[0020] FIG. 2b depicts another screen display;

[0021] FIG. 2c depicts another screen display;

[0022] FIG. 2d depicts another screen display;

[0023] FIG. 2e depicts another screen display.

[0024] The drawing figures do not limit the present invention to the specific embodiments disclosed and described herein. The drawings are not necessarily to scale, emphasis instead being placed upon clearly illustrating the principles of the invention.

DETAILED DESCRIPTION OF THE PREFERRED EMBODIMENTS

[0025] Turning now to the drawing figures, and particularly FIG. 1, certain components of a retail filling station 10 which may be used to implement the present invention are illustrated. The preferred retail filling station 10 broadly includes one or more storage tanks 12, 14 for receiving and storing gasoline, one or more storage tanks 16, 18 for receiving and storing fuel additives, and at least one pump assembly 20 operatively coupled with the storage tanks 12, 14, 16, 18 for pumping and dispensing gasoline and additives therefrom.

[0026] The storage tank 12 is preferably provided for storing regular unleaded gasoline and the storage tank 14 is provided for storing premium unleaded gasoline. However, these or additional tanks that may be provided for regular leaded gasoline, diesel fuel or other grades of unleaded gasoline.

[0027] Similarly, the storage tank 16 is preferably provided for storing ethanol and the storage tank 18 is provided for storing some other additive such as an octane-increasing chemical compound or some other biomass fuel. However, the storage tanks 16, 18 and/or additional storage tanks may be provided for other additives.

[0028] The storage tanks 12-18 are entirely conventional and are preferably buried below grade at the filling station 10. The storage tanks 12-18 are sized based on the demand

for the fuel or additives stored therein. For example, if the filling station 10 sells much more regular unleaded gasoline than premium unleaded, the storage tank 12 will be larger than the storage tank 14.

[0029] The filling station 10 preferably includes multiple pump assemblies 10; however, for purposes of describing the present invention, only one is depicted. The pump assembly 20 is mostly conventional and broadly includes submersible pumps 22, 24, 26, 28 located in each of the storage tanks 12-18, a nozzle/valve assembly 30 for dispensing fuels to an automobile or approved storage container, a keypad 32 or other input device for permitting customers to initiate and pay for fuel purchases, a computing device 34, and a display screen 36 for displaying information to customers.

[0030] The submersible pumps 22-28 are entirely conventional and are provided for pumping fuels and additives from the storage tanks 12-18. The nozzle/valve assembly 30 is also conventional and is operably coupled with the submersible pumps 22-28 by appropriate fluid-carrying conduits. The keypad 32 or input device is coupled with the computing device 34 for permitting customers to select the type of fuel desired and to pay for the fuel as discussed in more detail below. The computing device 34 may be any programmable device such as a processor or controller coupled with memory. The display screen 36 is operatively coupled with the computing device 34 for displaying information to customers as described in more detail below. The computing device is programmed to receive inputs from the keypad 32 and other input devices and to control operation of the submersible pumps 22-28, display 36 and other components of the pump assembly 20. The pump assembly 20 may also include a conventional credit card reader 38 and other controls and input devices coupled with and/or controlled by the computing device 34.

[0031] In accordance with one aspect of the present invention, the pump assembly 20 also includes a proportioner 40 interposed between the submersible pumps 22-28 and the nozzle/valve assembly 30. The proportioner 40 may be located in the main housing of the pump assembly or may be positioned elsewhere as a matter of design choice. As described in more detail below, the proportioner 40 blends or mixes gasoline pumped from the storage tanks 12, 14 with ethanol and/or other additives pumped from the storage tanks 16, 18. The proportioner 40 may be any device capable of blending or mixing fuels and additives such as those found in the Ovation® line of pumps manufactured by Dresser Wayne.

[0032] To implement the present invention, unblended gasoline and additives are first delivered to the filling station 10 and pumped into the storage tanks 12-18 in a conventional manner. The storage tanks can of course be re-filled as necessary.

[0033] A customer wishing to purchase fuel from the filling station 10 then drives up to the pump assembly 20 and selects the type of fuel and amount of desired additive, if any, with the keypad 32 or other input device. The display screen 36 may initially prompt the customer to select a type of gasoline as depicted in FIG. 2a. The display screen 36 may then list all available additives and prompt the user to select a desired additive for their fuel as depicted in FIG. 2b. If the user selects one of the additives, the display screen

then prompts the user to select the amount of additive as depicted in **FIG. 2c**. The user may do so by operating up and down arrows on the keypad **32** or by entering the percentage additive using numeric buttons on the keypad.

[0034] The computing device **34** then calculates or looks-up the cost of the blended fuel based on the amount of additive selected. Details of the selected fuel, including its cost, are then displayed as depicted in **2d**. For example, if the customer selected a blended fuel consisting of 95% premium unleaded gasoline and 5% ethanol, the computing device **34** calculates or looks up the cost of this blend and displays it on the display. The customer is then prompted to press the Select button or otherwise confirm the fuel selection.

[0035] The computing device **34** may also calculate or look up the cost of other blends and display these costs to the customer as depicted in **FIG. 2e** so the customer may make an informed decision as to the amount of additive desired. For example, if the customer selects a 5% ethanol blend, the computing device **34** may display a lower cost for a 10% ethanol blend to permit the customer to choose this blend instead. The computing device **34** and display **36** may also indicate the cost for adding other fuel additives such as octane-enhancing compounds, engine cleaners, etc. and allow the customer to select one of these other additives.

[0036] Once the customer has made his or her final decision as to the blend of fuel, the pumping assembly **20** begins pumping the gasoline and selected additive(s) from the appropriate storage tanks **12-18** and then mixes the gasoline and additive(s) with the proportioner **40**. Once the fuel has been properly blended, it is dispensed to the customer with the nozzle/valve assembly **30** in a conventional manner.

[0037] The computing device **34** may also store details of the blend selected by each customer along with a customer identifier for future reference. For example, if a customer selects a fuel consisting of 90% gasoline and 10% ethanol, data corresponding to this blend may be stored along with the customer's credit card number or other identifier. Then, when the customer next visits the filling station **10** and enters his or her credit card number or other identifier, the computing device **34** displays the same selected blend and asks the customer if he or she would like to purchase it again. This permits customers to more quickly and easily receive a desired fuel blend every time they visit the filling station **10**.

[0038] The computing device **34** may also be programmed to provide information to customers as to the appropriate amount of additive and may even limit the amount of additives that can be selected. For example, it is often recommended that a blended fuel contain no more than 50% ethanol. The computing device **34** may display such a warning and limit the amount of ethanol that can be selected to no more than 50%.

[0039] Although the invention has been described with reference to the preferred embodiment illustrated in the attached drawing figures, it is noted that equivalents may be employed and substitutions made herein without departing from the scope of the invention as recited in the claims. For example, although the present invention is particularly useful for blending gasoline with ethanol, any other additives may be used in addition to, or instead of, the ethanol.

Having thus described the preferred embodiment of the invention, what is claimed as new and desired to be protected by Letters Patent includes the following:

1. A method for blending and dispensing fuel comprising:
 - receiving and storing gasoline in a first tank at a filling station;
 - receiving and storing a fuel additive in a second tank at the filling station;
 - pumping a portion of the gasoline from the first tank and a portion of the additive from the second tank;
 - blending the gasoline pumped from the first tank with the additive pumped from the second tank to create a blended fuel; and
 - dispensing the blended fuel to a customer.
2. The method as set forth in claim 1, wherein the gasoline and the additive are blended with a chemical proportioner.
3. The method as set forth in claim 1, further including the step of permitting the customer to select a percentage of additive to blend with the gasoline.
4. The method as set forth in claim 3, further including the step of storing the percentage selected by the customer along with an identifier for the customer.
5. The method as set forth in claim 4, further including the step of displaying the stored percentage to the customer during subsequent trips to the filling station so that the customer may automatically select the percentage.
6. The method as set forth in claim 5, wherein the identifier is a credit card number used by the customer when paying for the blended fuel.
7. The method as set forth in claim 1, wherein the additive is selected from the group consisting of a biomass fuel, an octane enhancing compound and an engine cleaner.
8. The method as set forth in claim 7, wherein the biomass fuel is ethanol.
9. The method as set forth in claim 3, further including the step of determining a price for the blended fuel based on the percentage additive selected by the customer and displaying the price.
10. A filling station comprising:
 - a first tank for receiving and storing gasoline;
 - a second tank for receiving and storing an additive;
 - a pump assembly operably coupled with the first and second tanks and including
 - a first pump positioned in the first tank,
 - a second pump positioned in the second tank,
 - a proportioner operably coupled with the first and second pumps for blending a selected amount of gasoline pumped from the first tank with a selected amount of additive pumped from the second tank to create a blended fuel, and
 - a nozzle/valve assembly operatively coupled with the proportioner for dispensing the blended fuel to a customer.
11. The filling station as set forth in claim 10, the pump assembly further including an input device for permitting the customer to select a percentage of additive to blend with the gasoline.

12. The filling station as set forth in claim 11, the pump assembly further including a computing device for calculating a price for the blended fuel based on the percentage of additive selected by the customer.

13. The filling station as set forth in claim 11, the computing device being further operable for storing the percentage selected by the customer along with an identifier for the customer.

14. The filling station as set forth in claim 13, the computer device being further operable for presenting the percentage to the customer during subsequent trips to the filling station so that the customer may automatically select the percentage.

15. The filling station as set forth in claim 10, wherein the additive is ethanol.

* * * * *