

July 11, 1939.

C. T. HILL

2,165,547

FOOT ATTACHMENT FOR SKIS AND THE LIKE

Filed Dec. 16, 1936

2 Sheets-Sheet 1

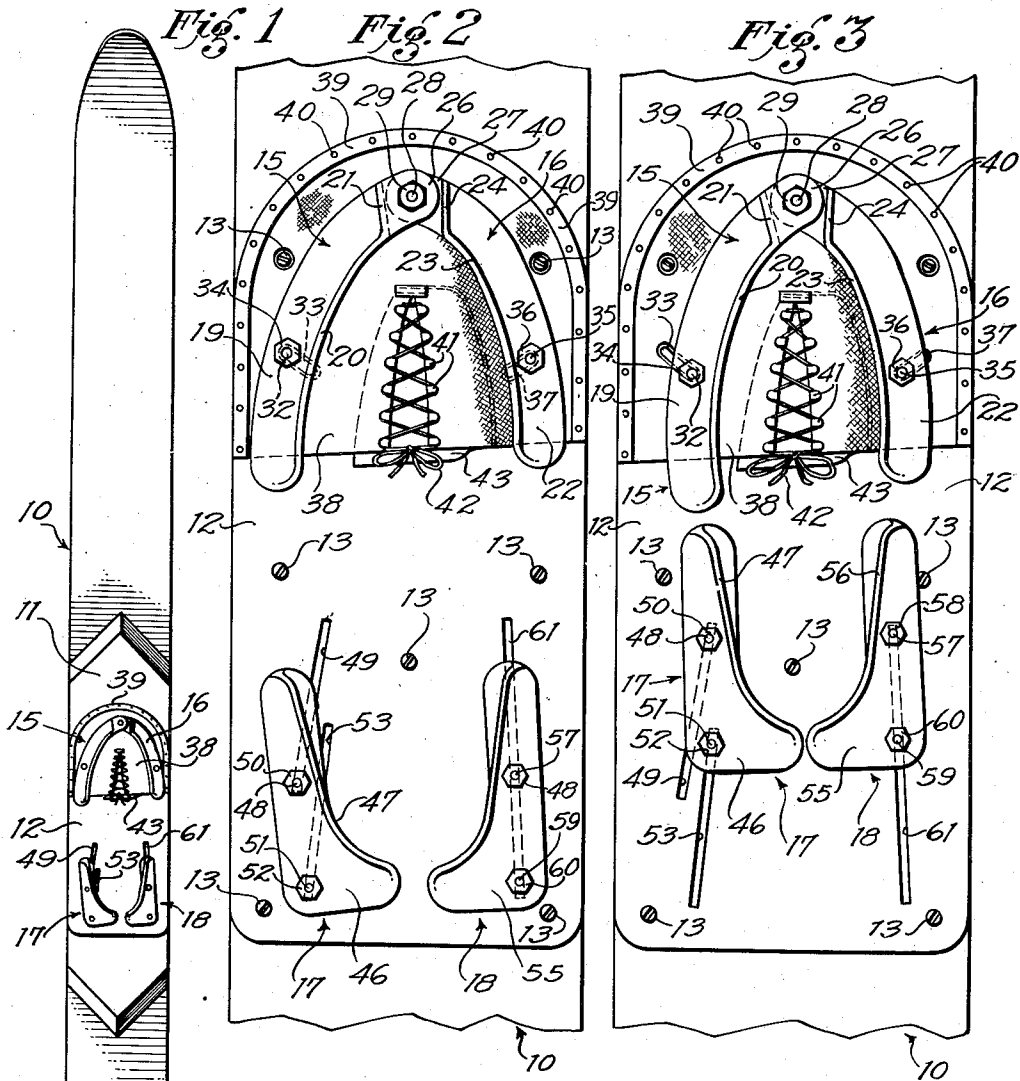

INVENTOR  
CORTLANDT T. HILL

by *M. W. O'Brien*

ATTORNEY

July 11, 1939.

C. T. HILL

2,165,547

FOOT ATTACHMENT FOR SKIS AND THE LIKE

Filed Dec. 16, 1936

2 Sheets-Sheet 2

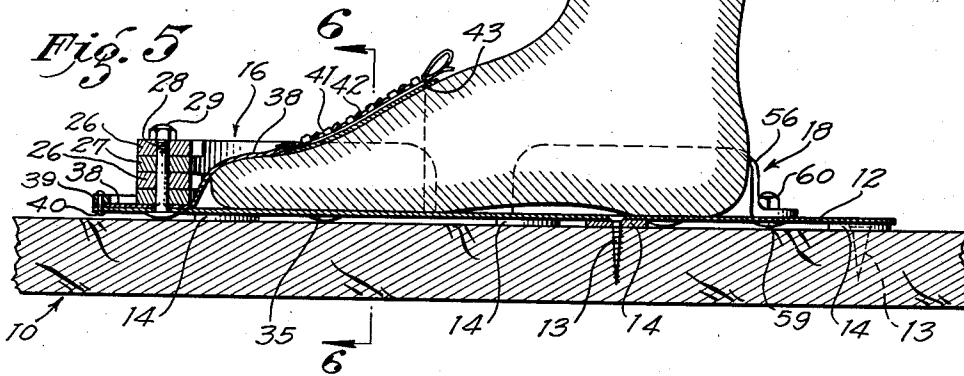
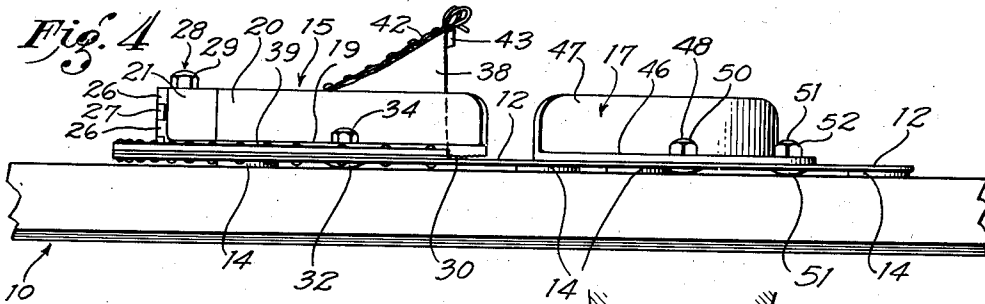
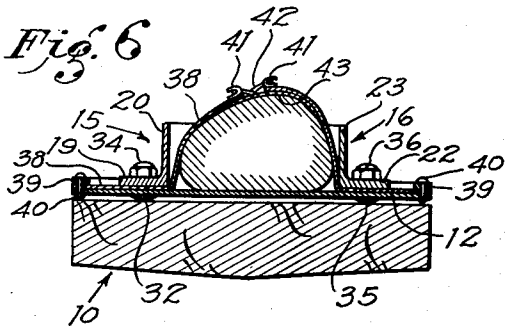
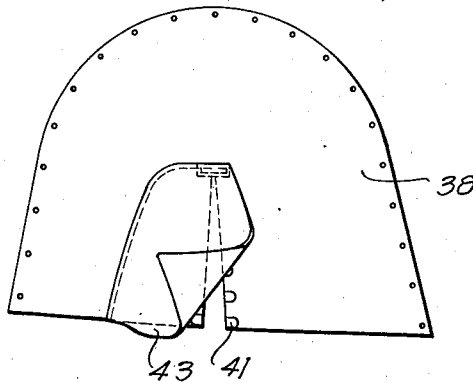

Fig. 7



INVENTOR  
CORTLANDT T. HILL

ATTORNEY

# UNITED STATES PATENT OFFICE

2,165,547

## FOOT ATTACHMENT FOR SKIS AND THE LIKE

Cortlandt T. Hill, Beverly Hills, Calif.

Application December 16, 1936, Serial No. 116,084

11 Claims. (Cl. 280—11.35)

My invention relates to foot-gear, particularly to means for attaching various types of foot-gear to the foot of the user, and is directed to an improvement in such means that is especially applicable to skis. That the principles of the invention may be readily applied to various types of foot-gear will be understood from the following example, a description of the invention specifically applied to water skis.

The usual means incorporated in a ski construction for attachment to a wearer's foot is either fixed in size and proportion to conform with the requirements of a given wearer, or else is adjustable by such an inexpedient and burdensome procedure that any practice of changing from one foot-size to another is effectively discouraged. Usually a tool is required, even when adjustment is contemplated by the manufacturer. Such adjustability as offered heretofore is generally too limited in kind and scope to permit adequate and satisfactory adaptation to a variety of foot-sizes. As a result, a pair of skis having the prevailing type of foot-retaining means is, in practice, restricted to the use of one person.

The general object of my invention is to provide, in a foot-attachment for skis and the like, quick, convenient, and flexible adjustability over an extensive range of normal foot requirements, such adjustability as will encourage the practice of putting a given pair of skis into the service of several persons.

It is my purpose to provide flexibility in width, length, and in tightness of fit over the wearer's foot, to the extent that the ski may be readily adapted to a normal foot in any combination of adjustments preferred by the individuals. A feature of my invention following from such wide adaptability is that the wearer may compensate for changes in stretch of material in the foot-attachment caused by stress in use, or caused by wetting and drying of the material, and may also change the adjustment from time to time with change of personal preference. These considerations are of major importance in the use of water skis, where confidence on the part of the wearer and the avoidance of injuries requires that the foot-attachment be adjusted in some respects for snugness to provide adequate control over the ski, and be adjusted loosely in other respects to permit the wearer to discard the ski instantly in an emergency.

Other objects and advantages of my invention, especially those relating to the comfort of the wearer and those relating to efficiency of engagement with the wearer's foot, will be best understood by reference to the detailed description to follow.

Broadly described, my invention comprises a forward pair of adjustably spaced foot-retaining

members, a flexible member associated therewith to extend adjustably over the wearer's foot, and means to engage the heel of the wearer, relative movement being provided between said means and said forward members.

In the accompanying drawings,

Fig. 1 is a plan view of a ski, on a reduced scale, showing my attachment mounted thereon for the left foot of the wearer;

Fig. 2 is a plan view, on a larger scale, of the central portion of the ski, showing my attachment adjusted for a relatively large foot;

Fig. 3 is a similar view with the attachment adjusted for a relatively small foot;

Fig. 4 is a side elevation of Fig. 3;

Fig. 5 is a longitudinal, medial section through Fig. 3, indicating the manner in which the wearer's foot fits into the attachment;

Fig. 6 is a transverse, vertical section taken as indicated by line 6—6 of Fig. 5; and

Fig. 7 shows the under side of a flexible member prior to assembly.

Ski 10 is centrally increased in thickness in the usual manner, as indicated at 11, for reinforcement where the ski receives the weight of the wearer. The movable parts of my foot-attachment are carried by a base-plate 12, which is detachably mounted on the ski by suitable screws 13. A necessary clearance between the base-plate and the ski may be provided by spacers 14 surrounding the screws, as indicated in Figs. 4 and 5.

Since, in foot-gear, parts on the left side of the left foot correspond to parts on the right side of the right foot, the terms "outside" and "inside" will be substituted for left and right, the terms "outside" and "inside" here used being associated with the outer and inner sides, respectively, of whichever foot is involved.

My invention includes a forward pair of adjustably spaced foot-engaging members comprising outside toe-block 15 and inside toe-block 16, and also includes a rearward pair of heel-engaging members, outside heel-block 17 and inside heel-block 18. Preferably, as may be noted by comparing Figs. 2 and 3, relative movement between the pair of toe-blocks and the pair of heel-blocks will be provided solely by movement of the latter.

Toe-block 15 curves to conform to the general configuration of a wearer's foot, and preferably comprises a horizontal base portion 19 resting on base-plate 12 and an upright flange 20 along the edge nearest the wearer's foot, this flange extending across the forward end of base 19, as indicated at 21.

The complementary toe-block 16, having a similar configuration, also has a horizontal base portion 22 and an upright flange 23 extending across the forward end at 24.

Preferably, the adjustable spacing of these two toe-blocks, to conform with different foot-widths, is provided by pivotally mounting them on base-plate 12 by their forward ends. The two toe-blocks may have a common pivot, the forward ends forming a hinge as shown. The knuckle of this hinge comprises two horizontal extensions 26 integral with end flange 21 of the outside toe-block, and two alternate, complementary, horizontal extensions 27 integral with end flange 24 of the inner toe-block, the pintle of the hinge being a suitable bolt 28, the lower end of which is non-rotatably mounted in base-plate 12. Bolt 28 is provided with a suitable hexagonal nut 29 that may be conveniently tightened by a suitable "key" or socket wrench to secure the assembly at any desired angular relation of the two members. Preferably, the underface of each of these forward members is roughened or corrugated, as indicated at 30 (Fig. 4.)

Base 19 of toe-block 15 is apertured to receive a suitable bolt 32 that slidably engages an arcuate slot 33 in base-plate 12 concentric with pintle 28. Preferably, the bolt has a square shank to prevent rotation in the slot when a hexagonal nut 34 on the upper end of the bolt is manipulated to clamp or unclamp the toe-block.

In similar manner, a bolt 35 having a nut 36 is provided for adjustably clamping toe-block 16 to the base-plate, the bolt engaging a complementary arcuate slot 37 also concentric with pintle 28.

Slots 33 and 37 are of sufficient extent to permit adjustment of the two toe-blocks through the normal range of narrow and wide feet. It will be noted that upright flanges 20 and 23, in addition to confining the foot of the wearer, serve as guards to protect the foot from bolts 32 and 35.

In the form of my invention here shown, toe-blocks 15 and 16 not only serve as means to restrain the ski against backward and lateral movement with respect to the foot of the wearer, but also cooperate with a flexible member 38 that serves as a casing extending over the instep to restrain the ski from downward movement away from the foot.

This casing, made of canvas or other suitable fabric, is secured at its forward and side margins to base-plate 12 by suitable means such as a U-shaped metal strip 39 and rivets 40. This flexible member extends under the two toe-blocks, having apertures registering with forward bolt 28 and the two arcuate slots 33 and 37, as well as with any screws 13 that would otherwise be inaccessible. This casing has the shape and construction of a shoe-upper, being slit longitudinally into two halves provided with hooks 41 adapted to be engaged by a shoe-lace 42. Preferably, a tongue 43 is sewn to the casing along an end and one side, as shown. The casing is laced up in the same manner as a shoe, the hook-and-lace construction providing means to adjust the casing for tightness of fit over the wearer's foot.

Passing the flexible member under the toe-blocks has several advantages. Among others, it prevents the foot of the wearer from coming into direct contact with the toe-blocks, and it also provides a yielding restraint tending to cushion violent movements of the foot against the unyielding sides of the toe-blocks. An important advantage of the arrangement is that adjustment of the toe-blocks regulates the effective width of the casing. Thus, as the toe-blocks are moved towards each other to conform with a narrow foot, slack in the width of the casing is auto-

matically taken up. This narrowing of the effective width of the casing approximates the requirements of feet of various widths within the range of further individual adjustment provided by the hook-and-lace construction.

The purpose of heel-blocks 17 and 18 is to provide means to keep the foot of the wearer under flexible member 38 by preventing forward movement of the ski with respect to the wearer's foot, and also to provide bearing surfaces to receive pressure laterally from the heel of the wearer for controlling the ski. A relatively loose fit meets these requirements and looseness rather than tightness of fit is essential to permit the wearer to discard the ski instantly in an emergency.

While a liberal tolerance in the fit of the heel-engaging means is contemplated, nevertheless it is desirable that such means be adjustable in width as well as in its spacing from the forward foot-engaging means. Since there is a certain correlation between lengths and widths of normal feet, at least a correlation that is commensurate with the tolerance of fit here permitted at the heel of the wearer, I find it convenient to combine adjustment in width with adjustment in the longitudinal position of the heel-engaging means, i. e., to arrange the heel-engaging means to narrow automatically as it is moved forward towards the toe-block. I also find it desirable, where a pair of heel-blocks of the shape shown is employed, to cause at least one of the blocks to rotate slightly as the pair is adjusted forward, such rotation conforming to narrower feet. The drawings indicate how these desired functions may be provided by mounting the two heel-blocks in suitably disposed slots in base-plate 12.

Outer heel-block 17 comprises a base portion 46 and an integral upright flange 47 to form a bearing surface for the heel of the wearer, this flange at the forward end inclining away from the vertical as shown. The forward portion of the heel-block is retained by a suitable bolt 48 thru base 46, the bolt being slidably and, preferably, non-rotatably mounted in an oblique slot 49 in base-plate 12. The bolt carries a suitable hexagonal nut 50. It will be noted that flange 47, in addition to offering a bearing surface to receive lateral pressure from the wearer's heel, serves as a guard to prevent injury to the wearer's foot by the bolt or nut.

The rear portion of heel-block 17 is secured by a second bolt 51 having a nut 52, the bolt being slidably and non-rotatably mounted in a second oblique slot 53 in base-plate 12. By disposing forward slot 49 at a slightly greater angle with respect to the longitudinal axis of the wearer's foot than rear slot 53, I cause the heel-block to rotate inward to a slight extent as it is moved forward, the rotation being apparent in a comparison of Figs. 2 and 3.

The configuration of inner heel-block 18 is similar to that of heel-block 17, the inner heel-block comprising a base portion 55 and an upright flange 56, this flange inclining away from the vertical at the forward end. The heel-block is adjustably secured by a forward bolt 57 having a nut 58 and a rearward bolt 59 having a nut 60, both bolts being slidably mounted in a common, oblique slot 61 in base-plate 12.

The toe-blocks and heel-blocks shown may be made of any suitable material such as wood, metal, or compositions similar to that known by the trade-mark "Bakelite".

The manner in which these two heel-blocks cooperate to engage the heel of the wearer will be

apparent from the drawings, and the manner in which the spacing between the two blocks narrows as they are moved forward will be readily understood.

5 To adjust my foot attachment in accordance with the requirements and preference of a particular wearer, the various nuts are loosened, and the wearer's foot is thrust forward on base-plate 12 under flexible member 38 to fit snugly against 10 the forward portions of the toe-blocks. The two toe members are then adjusted to conform with the wearer's foot and secured in their desired positions by tightening the three nuts 29, 34, and 15 36. The next operation, by preference, consists of moving the heel-blocks forward and securing them into positions desired by tightening their associated nuts. The final step is to lace together, across the foot, the two halves of casing 38.

20 The procedure required to change the adjustment of the attachment completely from one set of requirements to a different set of requirements for a different foot size, is a quick, simple process of no great inconvenience, and yet the adjustment once made is safe and as permanent as 25 may be desired. The whole foot attachment may be removed for transference from one pair of skis to another by simply taking out screws 13 thru baseplate 12.

30 The specific example herein described, as illustrative of my invention, suggests various changes in arrangement and construction without departure from the principles involved; and I reserve the right to all such changes and modifications that fall within the scope of my appended 35 claims.

Having described my invention, I claim:

1. A foot-attachment of the class described, having: a forward foot-engaging means adjustable in width and a rearward heel-engaging 40 means variable in width, said heel-engaging means being adjustable forward and backward and being constructed and arranged to automatically open to maximum width at its rearmost position and to close to minimum width at its fore- 45 most position.

2. A foot-attachment for a ski or the like, comprising: means on the ski to engage the forward end of a wearer's foot, said means being fixed against longitudinal movement; means variable in width to engage the heel of the wearer's 50 foot; and means for mounting the latter means on the ski for adjustment thru a range of longitudinal movement, said mounting means narrowing said variable means as the variable means is 55 moved forward, and vice versa.

3. A foot-attachment for a ski or the like, comprising: forward means on the ski to engage the wearer's foot, said means being adjustable in width and fixed against longitudinal movement; 60 rearward heel-engaging means variable in width mounted on the ski for adjustment thru a longitudinal range of positions; and means to automatically narrow the heel-engaging means as it is moved towards said forward means in approximation to the correlation of width of heel to 65 length of foot for normal feet.

4. A foot-attachment of the class described, having: a forward foot-engaging means variable in width; a base-plate having slots; and heel-engaging means variable in width mounted for adjustment in said slots, said slots being disposed to permit longitudinal movement of the heel-engaging means and being disposed to narrow the heel-engaging means as it is moved forward.

5. A foot-attachment of the class described, having: a forward foot-engaging means variable in width; a base-plate having slots; and a pair of heel-engaging members mounted for adjustment in said slots, said slots being disposed to permit longitudinal movement of said members, and being disposed to draw the members towards each other as they are moved longitudinally forward. 5

6. A foot-attachment of the class described, having: a forward foot-engaging means variable in width; a base-plate having slots; and a pair of heel-engaging members mounted for adjustment in said slots, said slots being disposed to permit longitudinal movement of said members, and being disposed to draw the members towards each other as they are moved longitudinally towards 10 the forward foot-engaging means and to simultaneously rotate one of said members. 15

7. In a device of the class described, the combination of: a member shaped to contact the side 20 and a portion of the rear of wearer's heel; a base-plate having a slot for the forward end of the member and a slot for the rear end of the member; and means for mounting the ends of the member for sliding adjustment in their corresponding slots; said slots being disposed at 25 angles to the longitudinal axis of the wearer's foot, the forward slot being at the greater angle to cause the forward end of the member to move towards said axis faster than the rear end as the 30 member is moved forward.

8. A foot-attachment of the class described, having: a base-plate; a pair of forward rigid members to extend along opposite sides of the 35 wearer's foot; means to releasably clamp said rigid members against the base-plate at adjusted portions; and a flexible member to extend over the wearer's foot, said flexible member being adjustably secured by said clamping of the rigid 40 members.

9. A foot-attachment of the class described, having: a base-plate; a pair of forward rigid members to extend along opposite sides of the 45 wearer's foot; manually-adjustable means to releasably clamp said rigid members against the base-plate at variably spaced positions; guards on said members to protect the wearer's foot from said adjustment means; and a flexible member to extend over the wearer's foot, said flexible member being adjustably secured by said clamping of 50 the rigid members.

10. A foot-attachment of the class described, having: a base-plate having arcuate slots; a pair of forward, arcuate foot-confining members; means mounted on the plate to pivotally retain 55 the forward ends of said members; manually-adjustable means cooperative with said arcuate slots to clamp said arcuate members to the plate at various angles with respect to each other; a flexible foot-confining means adjustably secured by 60 the clamping of said rigid members; and a means to engage the heel of the wearer, said means being movable towards and away from said pair of arcuate members.

11. A foot-attachment of the class described, 65 having, in combination: a base; a flexible casing for a wearer's foot, said casing being secured along edges to said base; and a forward foot-engaging means mounted on said base, said means being adjustable in width and superimposed on 70 said casing, thereby providing adjustment of the effective width of the casing.