



US 20050153788A1

(19) **United States**

(12) **Patent Application Publication**
Saldana

(10) **Pub. No.: US 2005/0153788 A1**

(43) **Pub. Date: Jul. 14, 2005**

(54) **PUTTING GAME SURFACE AND METHOD OF PLAY**

Publication Classification

(76) Inventor: **Todd Saldana**, Costa Mesa, CA (US)

(51) **Int. Cl.7** **A63B 69/36**

(52) **U.S. Cl.** **473/173**

Correspondence Address:

GENE SCOTT; PATENT LAW & VENTURE GROUP
3140 RED HILL AVENUE
SUITE 150
COSTA MESA, CA 92626-3440 (US)

(57) **ABSTRACT**

A golf game method comprises the steps of providing a planar playing surface having a width and a length; placing markings on the playing surface including a target area located near one end of the playing surface and a plurality of golf ball placements located at plural positions distanced from the target area. The game is played by putting golf balls from the golf ball placements to the target area and scoring the game in accordance with the final resting position of each golf ball in accordance with score markings in the target area.

(21) Appl. No.: **10/754,225**

(22) Filed: **Jan. 9, 2004**

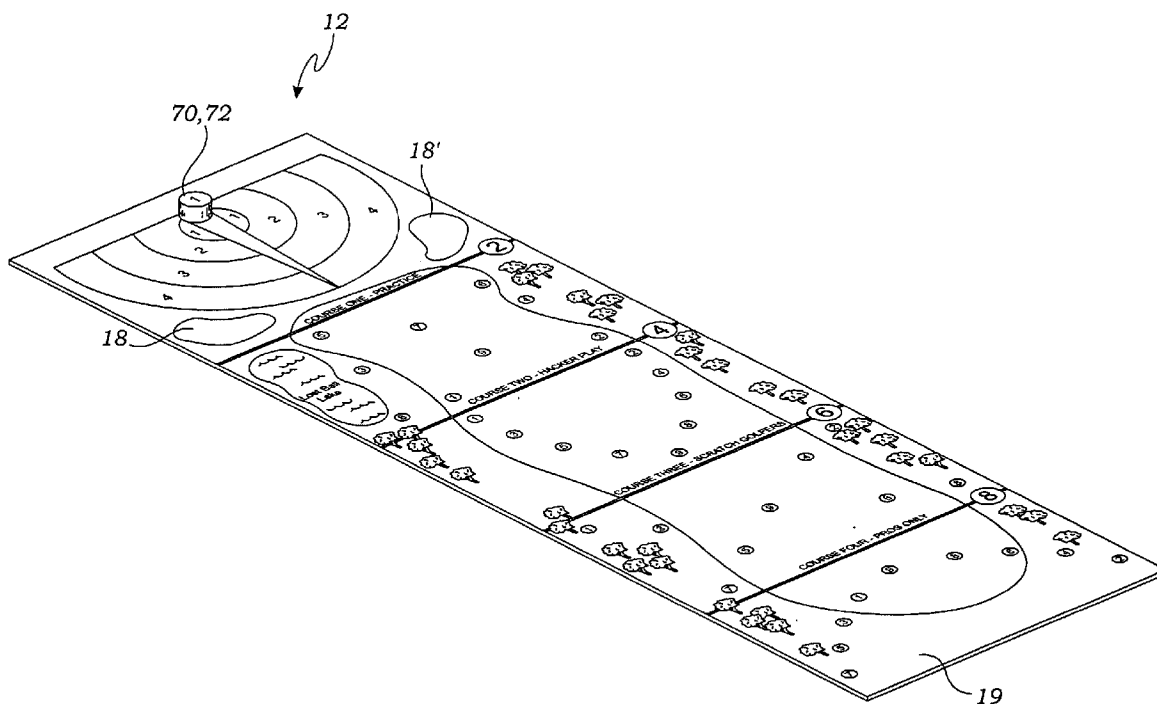

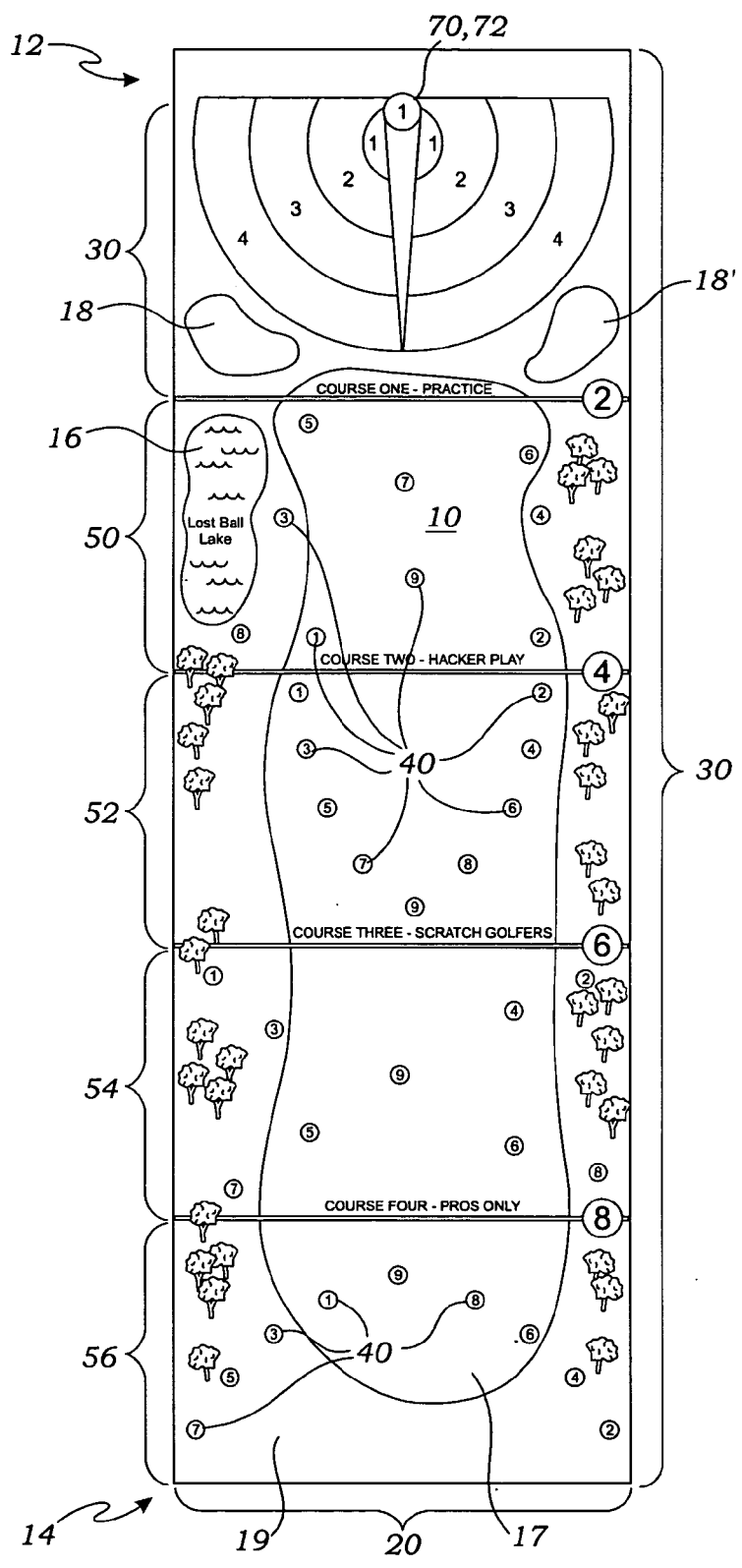

Fig. 1

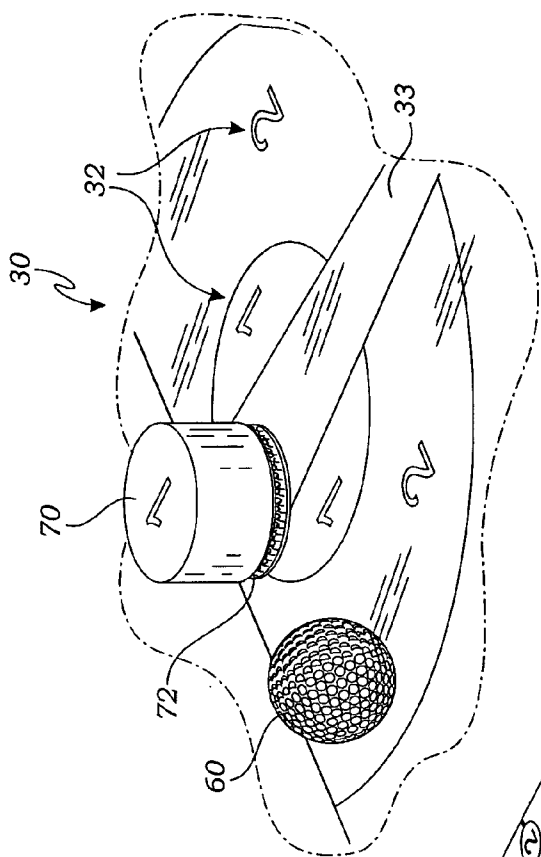

Fig. 3

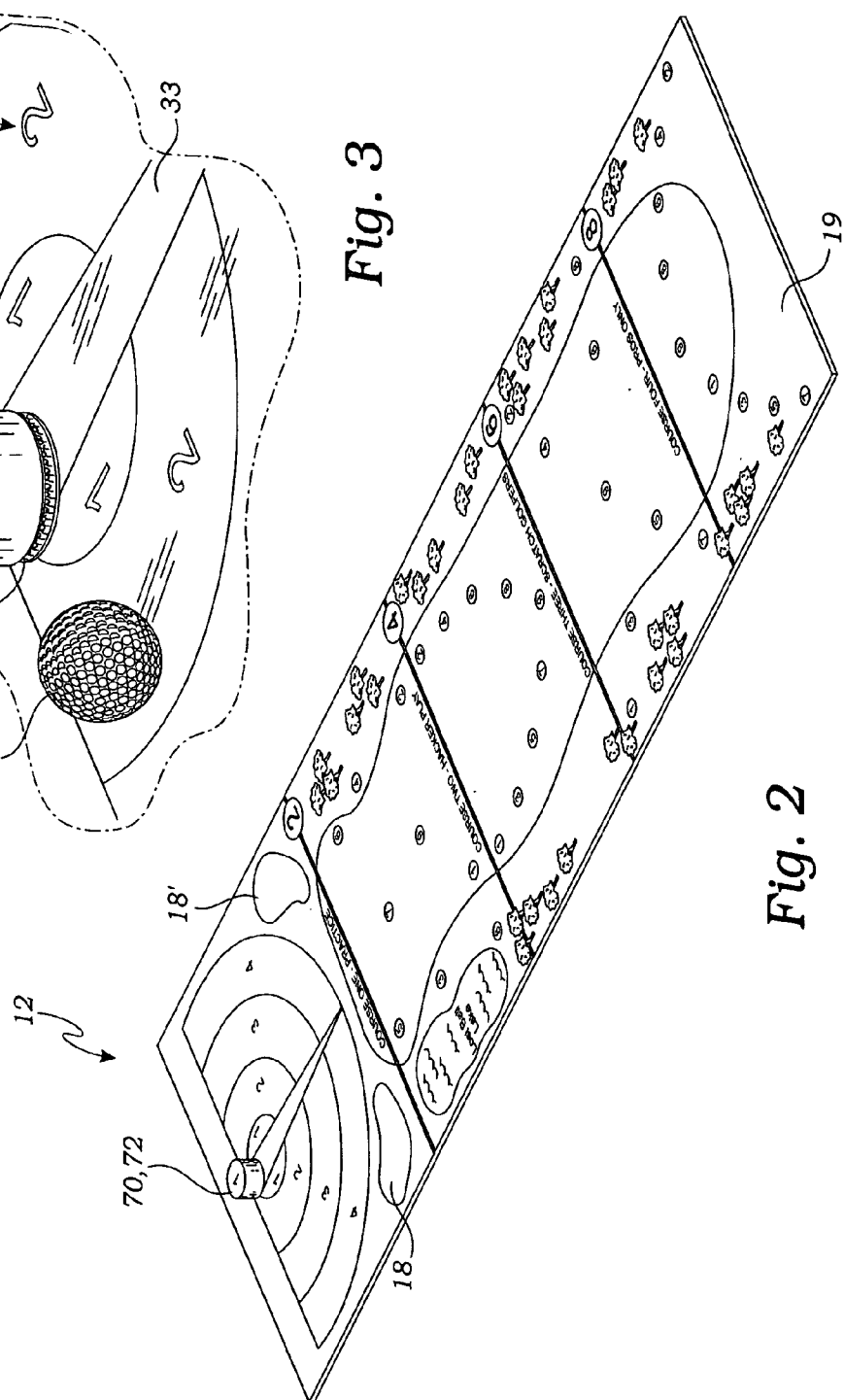

Fig. 2

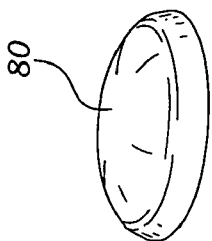

Fig. 4

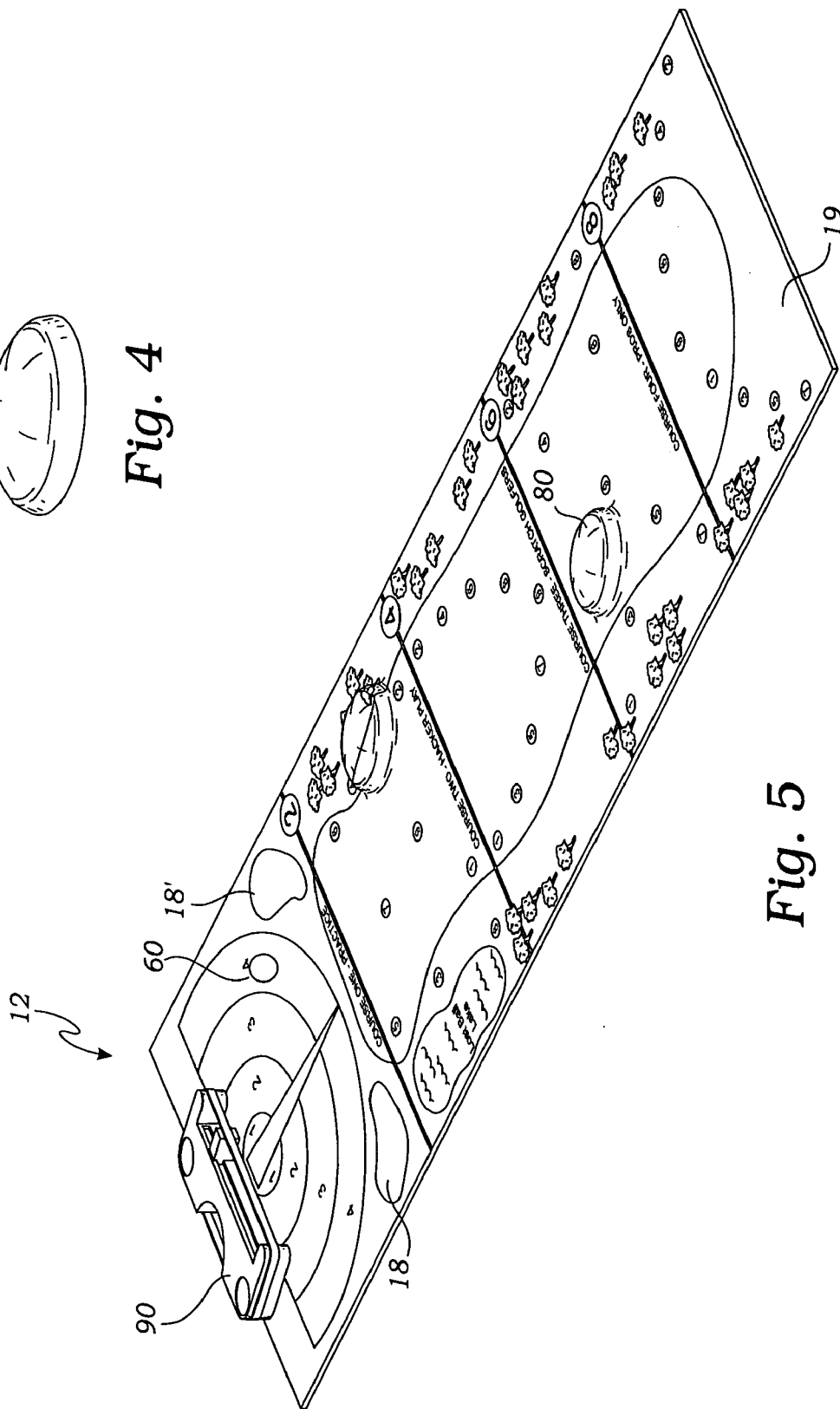

Fig. 5

PUTTING GAME SURFACE AND METHOD OF PLAY

RELATED APPLICATIONS

[0001] This application is related to an apparatus described in a U.S. application filed on Aug. 7, 2003 and having Ser. No. 10/637,368 and entitled, "Adjustable Golf Putting Feedback Leaning Apparatus."

INCORPORATION BY REFERENCE

[0002] Applicant(s) hereby incorporate herein by reference, any and all U. S. patents, U.S. patent applications, and other documents and printed matter cited or referred to in this application.

BACKGROUND OF THE INVENTION

[0003] 1. Field of the Invention

[0004] This invention relates generally to golf putting surfaces and in particular such a surface enabling a putting game between players.

[0005] 2. Description of Related Art

[0006] The following art defines the present state of this field:

[0007] Perrin, U.S. Des. 385,007 describes a putting mat design.

[0008] Soonlan, U.S. Des. 407,458 describes a golf putting mat design.

[0009] Rolfe, U.S. Pat. No. 1,338,963 describes a flat flexible playing surface, a mechanical trapping means for a ball that is situated on said surface and being entirely above said surface, said trapping means being adapted to release a ball if driven therein with a force exceeding a predetermined degree, markings on said surface surrounding the trapping means and delineating objective surfaces into which a ball may be rolled, and markings at differently spaced points from said trapping means to indicate "tee" positions for a ball.

[0010] Reirden, U.S. Pat. No. 1,679,374 describes a portable putting green, a flexible member having a putting surface and provided with an opening, and a collapsible cut mounted in said opening and capable of extension below said member and into a hole in the ground beneath said opening.

[0011] Wasley, U.S. Pat. No. 3,342,495 describes an indoor practice putting device comprising a mat with a playing surface having a rolling resistance to a golf ball approximating that of a natural outdoor green, a non-recessed simulated cup on said mat, an elongated horizontal spring member spanning said simulated cup in a position to be struck by a ball rolling toward the cup and cause the ball to rebound a distance which varies according to its approach velocity, and a line on said mat spaced a distance in front of said simulated cup to measure a rebound distance corresponding to the maximum ball velocity which would allow a ball to be retained by a standard recessed cup when passing across the center of the standard cup.

[0012] Florian, U.S. Pat. No. 3,584,877 describes a portable golf game using a golf club and a ball and including a

runner simulating a golfing green and having an inclined portion at the end of the runner with the incline and runner having selected scoring areas. The scoring area on the incline is a centrally located ball-receiving opening. The scoring area on the runner may be in the form of marks simulating s triangulated shuffleboard score area. The inclination of the incline is such that some balls traveling up the incline with inadequate momentum will reverse and roll down onto the scoring area on the runner. A vertical wall is provided beyond the upper end of the incline to form a backboard.

[0013] Buenzle, U.S. Pat. No. 3,843,136 describes a portable and compact golf practice and amusement apparatus wherein the players use regular golf balls and conventional type putters in playing on an elongated playing mat of flexible resilient material having a putting surface with material characteristics simulating an actual putting green as to drag and resistance to the rolling of a golf ball there across, a first golf ball trapping cup having a relatively small diameter and a shallow depth relative to the diameter of a golf ball and located slightly inwardly from the back edge of the mat, a second golf ball trapping cup having a relatively larger diameter and again having a shallow depth and located in the front end portion of the mat spaced inwardly from the front edge a substantial distance, a plurality of spaced apart markers positioned about the front end portion of the mat providing golf ball tee-off positions to facilitate utilization of the apparatus with each marker being appropriately identified by a marking indicia defining a preferential sequence of use of each marker, and a plurality of sections marked off on the back end portion of the mat defining different regions thereon that are used to govern the placement of the golf ball after each consecutive putting stroke.

[0014] Ren, U.S. Pat. No. 4,368,888 describes an elongate putting strip having a rebound block at one end thereof with a number of rebound faces at different widths arranged therearound. The block may be rotatably adjusted to present any of its faces to the length of the strip to require different degrees of putting skill. The rebound block also effective lengthens the putting path for the ball being driven along the strip. Each face of the rebound block is inclined relative to the vertical and the block has a layer of heavy, dense material positioned high enough to be struck by the ball to enhance the rebound action of the latter. The strip is hinged so that it may be folded into a compact package for carrying or storing purposes.

[0015] Park, U.S. Pat. No. 4,886,274 describes a portable practicing putting green having a putting surface band, a cup at one end of it, a square angle on the other end of it, and a rebound bar replacably put on either side of the square angle or near the hole, for rebounding golf ball. The square angle is bolted to one end of the putting surface band and to its standing side is outwardly bonded a rubber plate, which is perpendicular to the centerline of the putting surface band. The rebound bar has four exposed planar side surfaces with three of them bonded to a thin, medium, and thick rubber plates, respectively to provide different rebounding forces, and the remaining exposed remaining bare. When it is being carried or stored, the rebound square bar is put in between the inner sides of the square angle and the square angle and rebound bar are wound up inside putting surface band to minimize its volume.

[0016] Mull, U.S. Pat. No. 5,100,147 describes a putting stroke developer comprising of a target element that may be used with and without a putting surface element. Common to all embodiments of the inventive target element is the fact that the target element has a base surface that rests upon a putting surface as well as a vertically oriented, arcuately curved, relatively hard golf ball rebounding surface designed to produce a rebound that will indicate the accuracy of the line and force of a putt relative to the likelihood that the putt would have successfully landed within a regulation golf hole, and that the target element has sufficient mass to resist displacement, in an unsecured state, under the effect of a putted golf ball impacting against the rebounding surface. A putting surface element preferably simulates a putting green surface, and advantageously, is in the form of a mat to enable it to be rolled or folded for compact storage and transport. The mat has placement indicia for locating the target element thereon, and also has evaluating indicia for providing more accurate observational feedback as to the quality of a putt, both as a function of distance and angle of rebound.

[0017] Mull, U.S. Pat. No. 5,361,670 describes A putting stroke developer comprising of a target element that may be used with and without a putting surface element. Common to all embodiments of the inventive target element is the fact that the target element has a base surface that rests upon a putting surface as well as a vertically oriented, arcuately curved, relatively hard golf ball rebounding surface designed to produce a rebound that will indicate the accuracy of the line and force of a putt relative to the likelihood that the putt would have successfully landed within a regulation golf hole, and that the target element has sufficient mass to resist displacement, in an unsecured state, under the effect of a putted golf ball impacting against the rebounding surface. A putting surface element preferably simulates a putting green surface, and advantageously, is in the form of a mat to enable it to be rolled or folded for compact storage and transport. The mat has placement indicia for locating the target element thereon, and also has evaluating indicia for providing more accurate observational feedback as to the quality of a putt, both as a function of distance and angle of rebound.

[0018] Tu, U.S. Pat. No. 5,720,667 describes a golf targeting device having a targeting seat, a movable winder, and an artificial lawn fastened at both ends between the targeting seat and the movable winder. The targeting seat is provided with a resilient rubber pad having a grip and a targeting sign at the front end and an engagement body having a groove and two recesses at the rear end. The movable winder is formed by a square U-shaped holder pivotally joined to a cylinder and provided with a handle extending upwardly at the bottom middle section.

[0019] Kinney, U.S. Pat. No. 5,738,594 describes a mat including a top surface marked thereon dividing the top surface into a plurality of scoring areas. The scoring areas each have a scoring number marked therein. A boundary line is marked on the top surface of the mat dividing the top surface into two scoring zones, each of the scoring zones having a plurality of the scoring areas therein. Players use a golf club to attempt to hit a ball into the scoring zone across the boundary line from the player.

[0020] Barlow, U.S. Pat. No. 2003/0148813 describes a multiple molded polymeric panel mechanically fastened

together in a lengthwise configuration with a backboard at one end opposite the starting position for a putting stroke. Each panel has a planar top surface and a bottom integral grid supporting structure. The side edges of the panels are raised and the panels are attached together end to end. A simulated grass overlies the joined panels and a receptacle for receiving a golf ball is provided in one panel. A first carrying case contains the panels and backboard and a second carrying case contains the simulated grass and simulated flagstick.

[0021] Puttro Co., Ltd., WO 02/13919 describes a putting training mat. This mat has a base panel covered with an artificial lawn sheet. A plurality of tubes are longitudinally arranged on the lower surface of panel, and are different from each other in their slope angles and heights from a support surface when inflated with air. A variety of slopes are thus formed on the upper surface of the panel, and allow a user to practice putting on a complex sloped surface. In order to reinforce the polyurethane panel, a plurality of thin flat sticks are transversely and regularly set within the panel, and so the sticks maintain the horizontal surface or the sloped surface of the panel, in addition to maintaining the originally designed shape of the panel. The base panel is also tightly rolled when stored or carried.

[0022] Our prior art search with abstracts described above teaches: a putting stroke developer, portable practice putting greens, a golf putting device, a golf practice and amusement device, golf games, a golf targeting device, a portable indoor and outdoor putting green, a practice putting device, and putting mats, but does not teach a putting mat and game of the type described and claimed herein. The present invention provides further related advantages as described in the following summary.

SUMMARY OF THE INVENTION

[0023] The present invention teaches certain benefits in construction and use which give rise to the objectives described below.

[0024] A golf game apparatus and method comprises providing a planar playing surface having a width and a length; placing markings on the playing surface including a target area located near one end of the playing surface and a plurality of golf ball placements located at plural positions distanced from the target area; grouping the golf ball placements into putting areas of the playing surface, wherein each one of the putting areas extends across the full width of the playing surface and is contiguous with each next adjacent one of the putting areas in a succession of the putting areas proceeding away the target area to an other end of the playing surface in a stepwise order of positional difficulty of putting a golf ball from the golf ball placements within each of the putting areas to the target area. The game is played by putting golf balls from the golf ball placements to the target area and scoring the game in accordance with the final resting position of each golf ball in accordance with score markings in the target area.

[0025] A primary objective of the present invention is to provide an apparatus and method of use of such apparatus that yields advantages not taught by the prior art.

[0026] Another objective is to provide such an invention capable of providing a portable golf-play surface with formal rules of play.

[0027] A further objective is to provide such an invention capable of meeting the individual skill levels of players.

[0028] A still further objective is to provide such an invention capable of providing a competitive game method.

[0029] Other features and advantages of the present invention will become apparent from the following more detailed description, taken in conjunction with the accompanying drawings, which illustrate, by way of example, the principles of the invention.

BRIEF DESCRIPTION OF THE DRAWINGS

[0030] The accompanying drawings illustrate the present invention. In such drawings:

[0031] FIG. 1 is a plan view of a the invention a golf putting surface and game;

[0032] FIG. 2 is a perspective view thereof;

[0033] FIG. 3 is an enlarged partial perspective view thereof;

[0034] FIG. 4 is a perspective view of a relief bump thereof; and

[0035] FIG. 5 is a perspective view as in FIG. 2 but showing an alternate target device thereof and showing the use of the surface relief bump of FIG. 4.

DETAILED DESCRIPTION OF THE INVENTION

[0036] The above described drawing figures illustrate the invention in at least one of its preferred embodiments, which is further defined in detail in the following description. Those having ordinary skill in the art may be able to make alterations and modifications in the present invention without departing from its spirit and scope. Therefore, it must be understood that the illustrated embodiments have been set forth only for the purposes of example and that they should not be taken as limiting the invention as defined in the following.

[0037] The present invention is a golf game apparatus and method of play. The apparatus uses a planar playing surface 10 having a width 20 and a length 30 dimensions defining the overall extent of the playing surface 10. The playing surface 10 provides markings including a target area 30 located near one end 12 of the playing surface 10 and a plurality of golf ball placements 40 located at plural positions distanced from the target area 30. The golf ball placements 40 are grouped into discrete putting areas 50, 52, 54 and 56 on the playing surface, wherein each one of the putting areas 50, 52, 54 and 56 extend across the full width 20 of the playing surface 10 and are contiguous with each next adjacent one of the putting areas 50, 52, 54 and 56 in a succession of the putting areas 50, 52, 54 and 56 proceeding away the target area 30 to an other end 14 of the playing surface 10 in a stepwise order of positional difficulty of putting a golf ball 60 from the golf ball placements 40 within each of the putting areas 50, 52, 54 and 56 to a rebounding surface 70 positioned above the playing surface 10 in the target area 30.

[0038] The rebound surface 70 is preferably a post mounted to the playing surface 10 by a means for attachment 72 such as Velcro® fasteners. Such a post may be circular,

flat or may take whatever surface conformation is desired. The rebound surface 70 is preferably “live” as would be possible if made of a wood, or it may be resilient (rubber, etc.), but in any case, the rebound surface 70 should deflect the golf ball 60 when it is struck by it, with the golf ball 60 moving away from the rebound surface 70 in accordance with its incoming velocity. In this case, the ball 60 will terminate further from the rebound surface 70 if it arrives with a greater velocity.

[0039] In one preferred embodiment, the rebound surface 70 is a resilient surface (rubber band) that is stretched across an open recess, as shown in FIG. 5, so that when the ball 60 strikes the resilient surface, the surface deflects the ball 60 in accordance with its incoming direction. This device, shown as item 90 in FIG. 5, is described in a co-pending application having Ser. No. 10/036,017 and is incorporated into the present application by reference.

[0040] Preferably, each of the putting areas 50, 52, 54 and 56 provides nine of the golf ball placements 40 and in at least one of the putting areas, the nine golf ball placements 40 are randomly spaced. Each of the nine golf ball placements 40 corresponds to one hole of a nine-hole golf course so that a standard score card may be used with the present game.

[0041] Preferably, as shown in FIG. 1, the markings include at least one of a water hazard area 16, and a sand trap hazard area 18 or 18'. Further, preferably, the markings include a fairway area 17 and a rough area 19.

[0042] Preferably, at least one of the putting areas 50, 52, 54 and 56 is approximately 2 feet in length and of a width 20 which is equal to the width of the playing surface 10. Such a distance of 2 feet is the necessary condition for moving from one golf level of proficiency to the next. For instance, the areas 50, 52, 54 and 56 may fairly represent the golf levels respectively, which are usually referred to as: beginner, intermediate, scratch and professional levels. The beginner putting area 50 may be considered to present a putting range useful for practice and is so marked on the surface 10. Of course, putting practice may be taken from any location on the playing surface 10.

[0043] Preferably, the playing surface 10 forms one side of a flexible material such as a cloth, a plastic film, a rubber mat or similar materials. In this manner, the apparatus is easily stored in a rolled state or moved from place to place. In another usage of the present invention, the playing surface 10 may be formed on a hard surface such as concrete or asphalt and in this case would not be movable.

[0044] When the playing surface 10 is part of a flexible material, as defined above, the invention may further encompass at least one bump 80 positioned under the playing surface 10 for distorting the playing surface into a non-planar surface so as to increase the difficulty factor in the game. Such a bump 80 may be a plastic cup or similar object that is easily placed below the playing surface 10 at a selected position which may be changed from game to game. See FIG. 5.

[0045] In the above described apparatus the golf game method comprises providing the planar playing surface 10; placing the markings on the playing surface as described above; putting golf balls 60 from the golf ball placements 40 to the target area 30 and scoring the game in accordance with the final resting position of each golf ball 60 in accordance

with score markings **32** in the target area **30**, as best seen in **FIG. 3**. The method further comprises the step of penalizing a score when a golf ball **60** terminates in at least one of the water hazard area **16**, the sand trap hazard area **18** or **18'** and a rough area **19** which surrounds a fairway area **17**.

[0046] The method further comprises the step of placing at least one of the bumps **80** under the playing surface **10** thereby distorting the playing surface **10** into a non-planar surface and making the accurate putting of the golf ball **60** much more difficult.

[0047] A typical game is played by from two to four players. Each in turn places their golf ball **60** at the golf ball placement **40** identified with a numeral **1** and strokes the ball **60** with a putter golf club (not shown) toward the target area **30** to preferably strike the rebound surface **70**.

[0048] When such a strike is made with the ball **60** coming to rest immediately at the rebound surface **70** so that no rebounding occurs, the ball **60** is in area marked "1" i.e. a hole in one. The ball **60** is also considered to be in area **1** if it comes to rest in the extended triangular area **33**. However, if the ball **60** strikes the rebound surface **70** with some speed, the ball **60** will bounce and come to rest in one of the concentric surfaces marked with a numeral "2", "3" or "4". These numerals **1-4** represent the number of strokes that are scored for the respective balls **60** that come to rest in these areas. For instance, if one's golf ball **60** comes to rest in the area marked "3" or rebounds into that area, the player receives 3 strokes for the putt. If a ball comes to rest in a trap and an additional stroke is necessary, a penalty may apply so that a 3 stroke termination may actually be scored a 5. Players of differing proficiency may compete by using different putting areas **50**, **52**, **54** and **56**. For instance, a professional level golfer may use the putting area **56**, while a beginner competitor might use the putting area **50**. Each player uses the ball placements **40**, in turn, starting with the placement marked with a "1" and finishing with the placement marked with a "9" and counts the strokes accorded to each putt in accordance with the markings, actual strokes made and penalties to achieve a final score for each "hole."

[0049] The words used in this specification to describe the invention and its various embodiments are to be understood not only in the sense of their commonly defined meanings, but to include by special definition in this specification: structure, material or acts beyond the scope of the commonly defined meanings. Thus if an element can be understood in the context of this specification as including more than one meaning, then its use must be understood as being generic to all possible meanings supported by the specification and by the word or words describing the element.

[0050] The definitions of the words or elements of this described invention and its various embodiments are, therefore, defined in this specification to include not only the combination of elements which are literally set forth, but all equivalent structure, material or acts for performing substantially the same function in substantially the same way to obtain substantially the same result. In this sense it is therefore contemplated that an equivalent substitution of two or more elements may be made for any one of the elements in the invention and its various embodiments below or that a single element may be substituted for two or more elements in a claim.

[0051] Changes from the claimed subject matter as viewed by a person with ordinary skill in the art, now known or later

devised, are expressly contemplated as being equivalents within the scope of the invention and its various embodiments. Therefore, obvious substitutions now or later known to one with ordinary skill in the art are defined to be within the scope of the defined elements. The invention and its various embodiments are thus to be understood to include what is specifically illustrated and described above, what is conceptually equivalent, what can be obviously substituted, and also what essentially incorporates the essential idea of the invention.

[0052] While the invention has been described with reference to at least one preferred embodiment, it is to be clearly understood by those skilled in the art that the invention is not limited thereto. Rather, the scope of the invention is to be interpreted only in conjunction with the appended claims and it is made clear, here, that the inventor(s) believe that the claimed subject matter is the invention.

What is claimed is:

1. A golf game apparatus comprising: a planar playing surface having a width and a length defining an extent thereof; the playing surface providing markings including a target area located near one end of the playing surface and a plurality of golf ball placements located at plural positions distanced from the target area; the golf ball placements grouped into putting areas of the playing surface, wherein each one of the putting areas extends across the full width of the playing surface and is contiguous with each next adjacent one of the putting areas in a succession of the putting areas proceeding away the target area to an other end of the playing surface in a stepwise order of positional difficulty of putting a golf ball from the golf ball placements within each of the putting areas to a rebounding surface positioned above the playing surface in the target area.

2. The apparatus of claim 1 wherein the rebound surface is a post mounted to the playing surface by a means for attachment.

3. The apparatus of claim 1 wherein the rebound surface is resilient.

4. The apparatus of claim 3 wherein the resilient surface is stretched across an open recess.

5. The apparatus of claim 1 wherein each of the putting areas provides nine of the golf ball placements and in at least one of the putting areas, the nine golf ball placements are randomly spaced.

6. The apparatus of claim 1 wherein the markings include at least one of a water hazard area and a sand trap hazard area.

7. The apparatus of claim 1 wherein the markings include a fairway area and a rough area.

8. The apparatus of claim 1 wherein at least one of the putting areas is approximately 2 feet in length and of a width equal to the playing surface.

9. The apparatus of claim 1 wherein the playing surface forms one side of a flexible material.

10. The apparatus of claim 9 further comprising at least one bump positioned under the playing surface for forming the playing surface into a non-planar surface.

11. A golf game method comprising the steps of: providing a planar playing surface having a width and a length defining an extent thereof; placing markings on the playing surface including a target area located near one end of the playing surface and a plurality of golf ball placements

located at plural positions distanced from the target area; grouping the golf ball placements into putting areas of the playing surface, wherein each one of the putting areas extends across the full width of the playing surface and is contiguous with each next adjacent one of the putting areas in a succession of the putting areas proceeding away the target area to an other end of the playing surface in a stepwise order of positional difficulty of putting a golf ball from the golf ball placements within each of the putting areas to the target area; putting golf balls from the golf ball placements to the target area and scoring the game in accordance with the final resting position of each golf ball in accordance with score markings in the target area.

12. The method of claim 11 further comprising the step of providing a resilient surface in the target area.

13. The method of claim 11 further comprising the step of stretching the resilient surface across an open recess.

14. The method of claim 11 further comprising the step of randomly positioning the golf ball placements within at least one of the putting areas.

15. The method of claim 11 further comprising the step of penalizing a score when a associated golf ball terminates in at least one of a water hazard area, a sand trap hazard area and a rough area.

16. The method of claim 11 further comprising the step of placing at least one bump under the playing surface thereby forming the playing surface into a non-planar surface.

* * * * *