

(12) **UK Patent Application** (19) **GB** (11) **2 363 522** (13) **A**

(43) Date of Printing by UK Office 19.12.2001

(21) Application No **0119556.9**

(22) Date of Filing **02.02.2000**

(30) Priority Data

(31) **33599** (32) **23.02.1999** (33) **CH**

(86) International Application Data

**PCT/CH00/00056 De 02.02.2000**

(87) International Publication Data

**WO00/50946 De 31.08.2000**

(51) INT CL<sup>7</sup>

**G02B 6/12 6/43**

(52) UK CL (Edition S )

**H1R RAS  
G2J JGDBX**

(56) Documents Cited by ISA

**EP 0581012 A WO 90/01176 A US 5249245 A**

(58) Field of Search by ISA

INT CL<sup>7</sup> **G02B**

(71) Applicant(s)

**PPC Electronic AG  
(Incorporated in Switzerland)  
Riedstrasse 2, 6330 Cham, Switzerland**

(74) Agent and/or Address for Service

**Urquhart-Dykes & Lord  
30 Welbeck Street, LONDON, W1G 8ER,  
United Kingdom**

(72) Inventor(s)

**Peter Leo Straub**

(54) Abstract Title

**Printed circuit board for electrical and optical signals and method for producing the same**

(57) The invention relates to a printed circuit board (30) which has at least one electrical conduction level (EL) for relaying electrical signals and/or currents and at least one optical conduction level (OL) for relaying optical signals. Said conduction levels (EL, OL) are placed on top of each other in a stack inside the printed circuit board (30) and are interconnected. The aim of the invention is to provide a particularly flexible and simple construction and a simplified production method. To this end, the optical conduction level (OL) comprises at least one thin glass layer (11) as a conductor element.

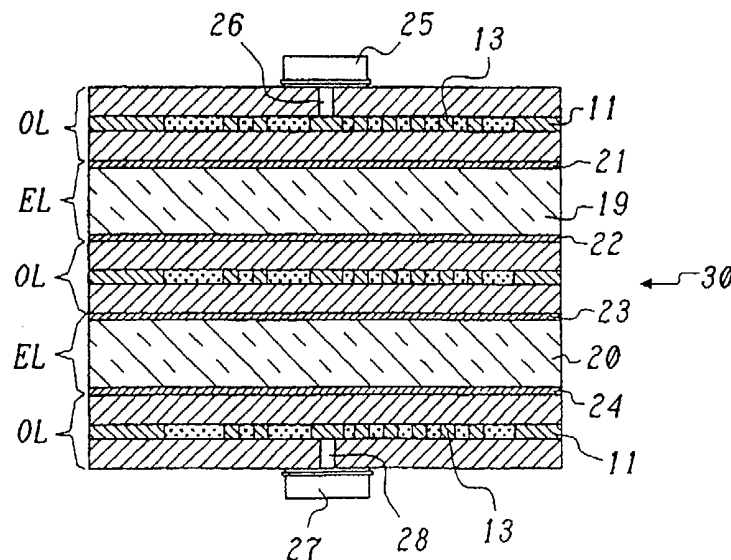

**GB 2 363 522 A**

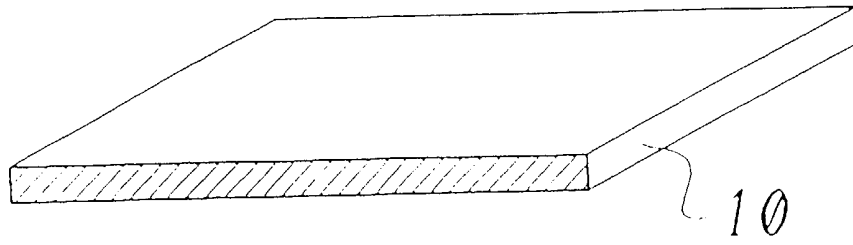

Fig. 1A

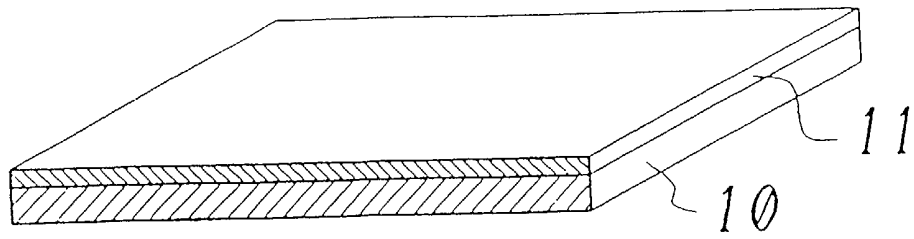

Fig. 1B

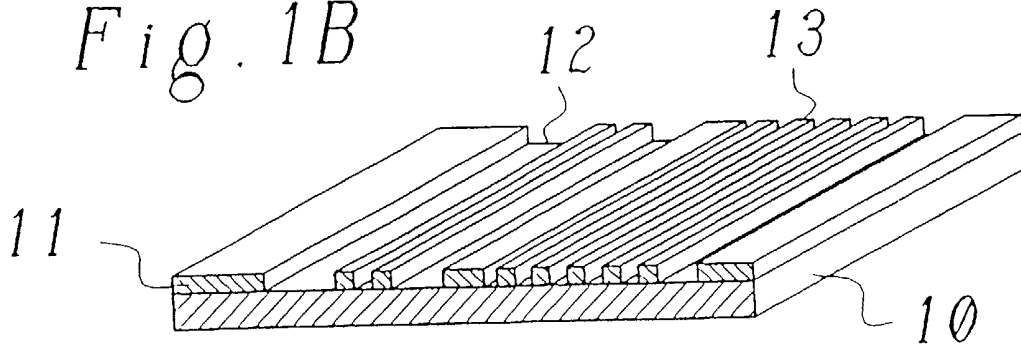

Fig. 1C

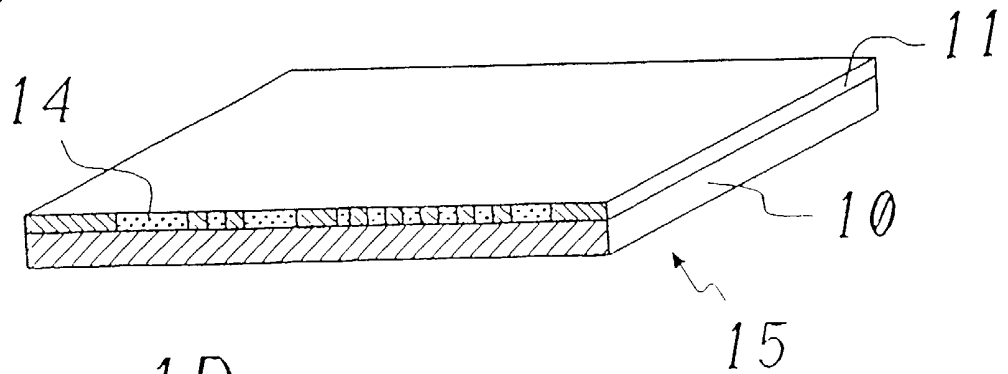

Fig. 1D

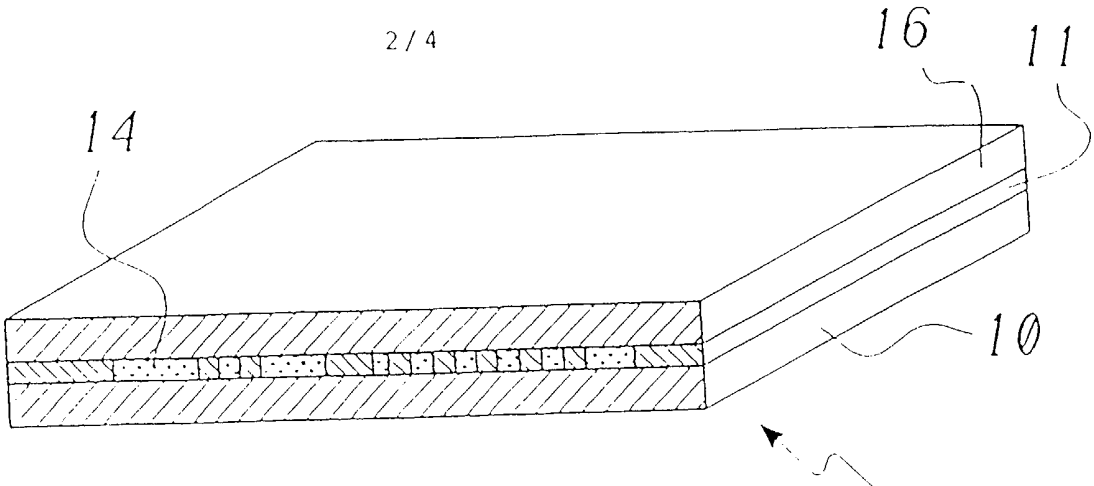

Fig. 2

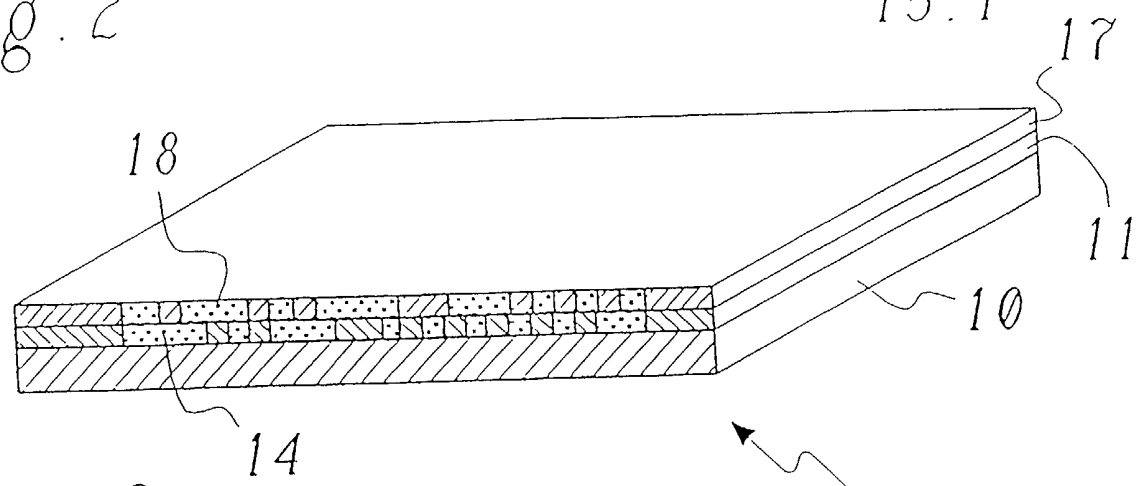

Fig. 3

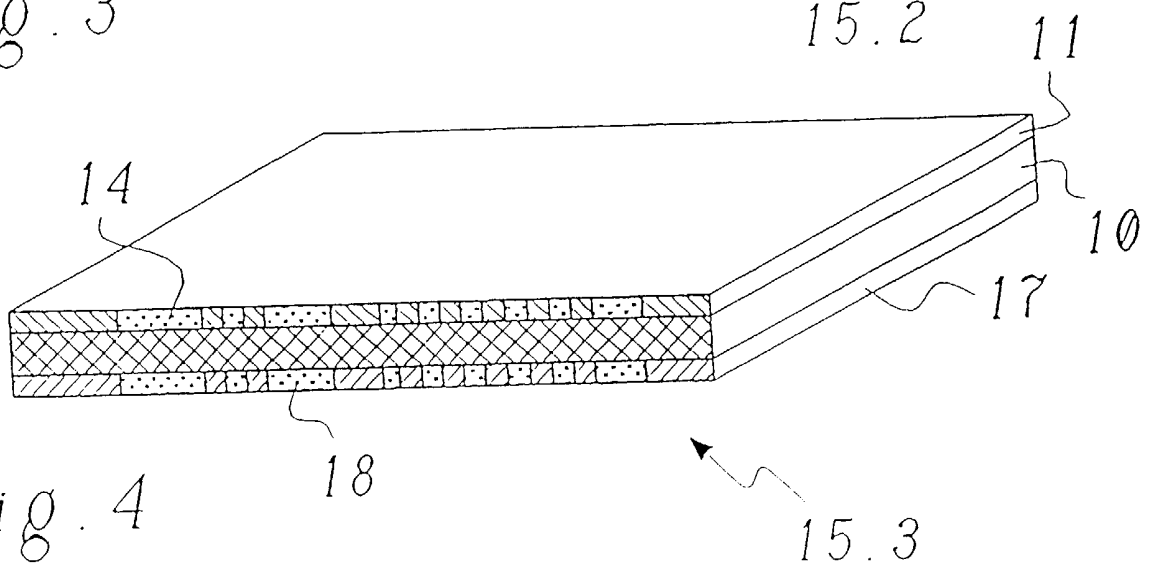

Fig. 4

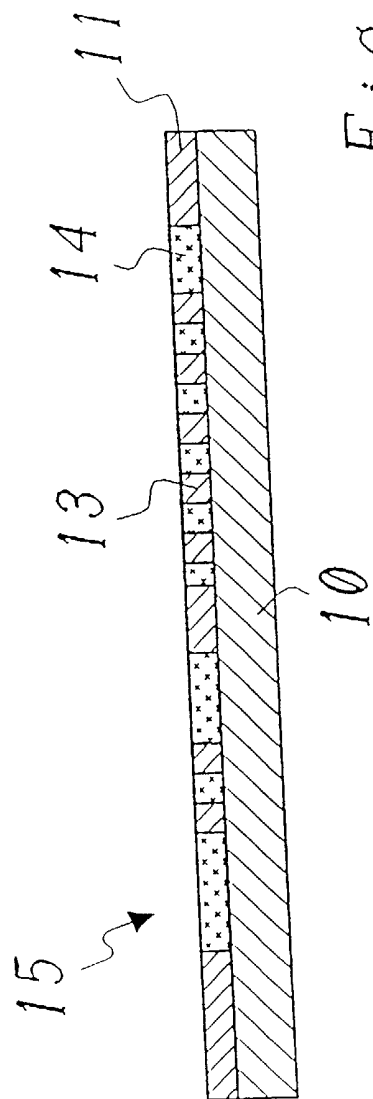

Fig. 5

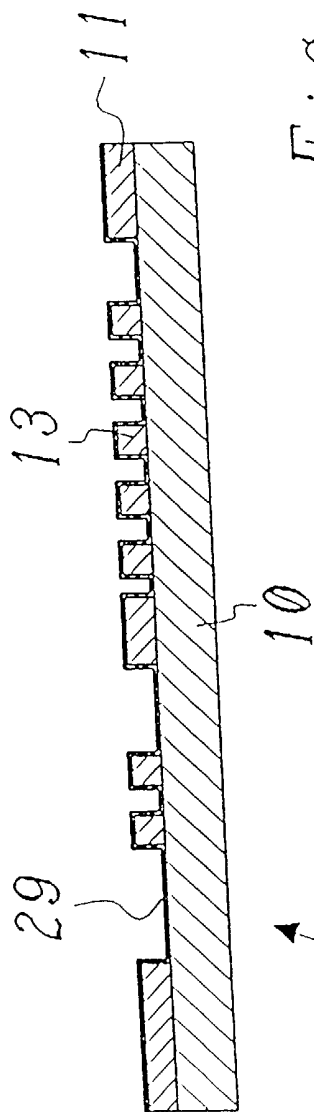

Fig. 6

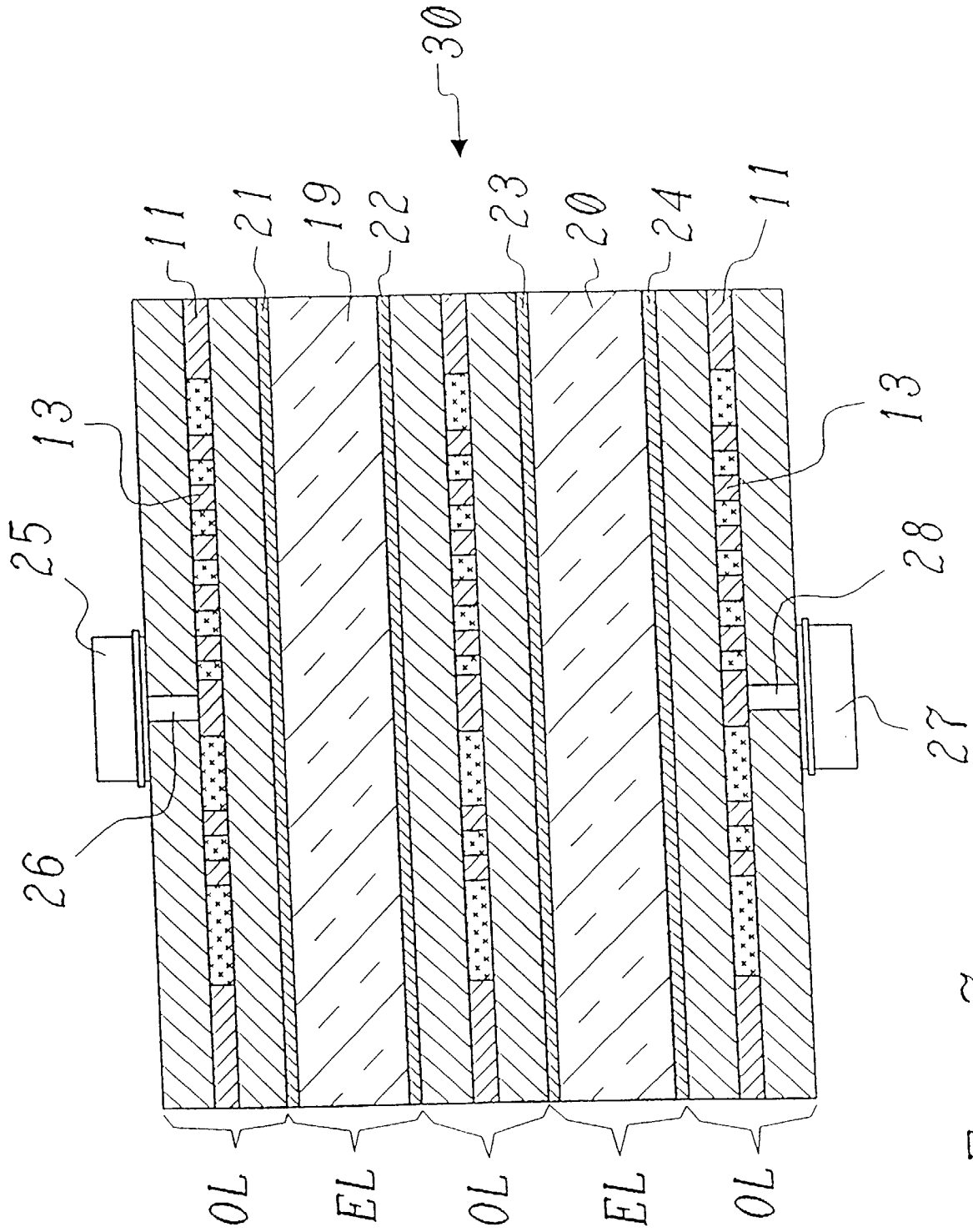

FIG. 7

## DESCRIPTION

### PRINTED CIRCUITBOARD FOR ELECTRICAL AND OPTICAL SIGNALS AND METHOD FOR PRODUCING THE SAME

#### TECHNICAL BACKGROUND

The present invention relates to the field of circuitboard technology. It concerns a circuitboard having at least one electrical conduction level for relaying electric signals and/or currents and at least one optical conduction level for relaying optical signals, said conduction levels being interconnected and arranged one above the other in a stack within the printed circuitboard.

Such a circuitboard is disclosed, for example, in the publication U.S. Patent No. 5,408,568 A.

This invention also relates to a method of producing such a circuitboard.

#### STATE OF THE ART

In the long run, the demand for higher and higher clock rates and faster and faster signal transmission cannot be met with an adequate quality by using copper lines. Through the use of optical transmission pathways (optical fibers) it is possible to transmit signals at extremely high transmission rates within a backplane and also on system boards. A high interference immunity with respect to electromagnetic interference is a very fortunate side effect which is important especially on an electric backplane. Such a backplane is responsible, for example, for the data exchange between the individual processor cards of a multiprocessor high performance computer.

Various proposals have already been made for integrating optical data transmission pathways into multilayer circuitboards. For example, U.S. Patent No. 5,230,030 A describes an optical interface for coupling to an electronic circuit in the form of multichip modules. The individual ICs are mounted on a multilayer circuitboard consisting of layers that conduct electricity, arranged in alternation with insulating layers in the form of a stack. Channels are created in the insulating layers, which consist of an optically transparent material having a low refractive index, and are then filled with another transparent plastic having a higher refractive index. The fillings then form optical conductors which are connected to the ICs on the one hand and on the other hand are led to the edge of the stack, where they can be connected externally by means of an appropriate plug. This method of integrating optical conductors into a circuitboard is not only complicated because the circuitboard must be built up and structured layer for layer in succession, but also the quality of the optical conductors produced in this way leaves much to be desired because it is very difficult to achieve a uniform and homogeneous conductor structure when filling the channels with the optically active material.

Another proposal which is disclosed in U.S. Patent No. 5,408,568 A cited above integrates a whole-area optical layer as an intermediate layer into a multilayer circuitboard. The optical layer is coupled to the outside by means of an optical fiber with a blunt connection on one end. Chips placed on the top side of the circuitboard are connected through holes beneath the chips, extending to the optical layer. The optical layer acts as a uniform optical databus over which all chips can exchange data with each other or with the outside world. No statements are made in that publication regarding the thickness or material of this optical layer. Figure 1 of that publication illustrates the optical layer with the same thickness as the printed circuitboards between which it is arranged. Therefore, this type of design could not be suitable for circuitboards having multiple optical levels and defined optical connections between selected chips.

#### EXPLANATION OF THE INVENTION

Therefore, the object of this invention is to create a circuitboard for electrical and optical signals which is characterized by a high quality of the

optical connection, a flexibly adaptable and easily varied design and simple integration into known manufacturing methods for multilayer circuitboards.

This object is achieved with a circuitboard of the type defined in the preamble by the fact that the optical conduction level as a conducting element comprises at least one thin glass layer. A thin glass layer is understood to refer to a sheet-like layer of glass with a small thickness (approximately 1 mm thick or less) but at the same time a high optical quality (planarity of the surfaces) such as that used for LCD displays, solar cells or as a cover for a CCD circuit. Due to the use of such thin glass layers, it is possible to provide within the circuitboard one or more space-saving optical conduction levels of a high transmission quality which can also be structured easily as needed to implement a localized optical connection within the circuitboard,

A first preferred embodiment of the circuitboard according to this invention is characterized in that the optical conduction level is formed by an optical sandwich which comprises, in addition to the minimum of one thin glass layer, at least one carrier plate which is connected to the minimum of one thin glass layer over the surface. Due to the combination of the thin glass layer with a carrier plate, it is possible to prefabricate the resulting optical sandwich separately from the fabrication of the actual circuitboard and to adapt it in a flexible manner to the prevailing needs of the circuit (e.g. by structuring). The prefabricated optical sandwich can be introduced as an additional conduction level or layer into a traditional manufacturing process for a multilayer circuitboard without requiring any significant changes in the process management.

It is possible here for the optical sandwich to comprise at least two carrier plates with the minimum of one thin glass layer arranged between them. The thin glass layer is then completely protected for further processing. However, it is also equally possible for the optical sandwich to comprise at least two thin glass layers which are connected to the minimum of one carrier plate over the area, with either the minimum of two thin glass layers being arranged on one side of the minimum of one carrier plate and joined together over the area or the minimum of two glass layers being arranged



on opposite sides of the minimum of one carrier plate. In this way, two different optical conduction levels that can be designed separately can be integrated into the circuitboard per optical sandwich. Of course, the number of carrier plates and thin glass layers per optical sandwich can also be increased further within the scope of this invention, although this does make production more complicated.

A second preferred embodiment of the circuitboard according to this invention is characterized in that the carrier plates are made of an electrically insulating material which is used as the basic material for the production of electric circuitboards, preferably an Aramid-reinforced resin. This guarantees that the optical sandwich can be introduced especially well into the traditional manufacturing process for multilayer circuitboards.

The thin glass layers preferably have a thickness of less than or equal to 1.1 mm and are made of a borosilicate glass. Such a thin glass which is available under the brand names AF 45 and D 263 from the German company DESAG for use in LCD displays or solar cells, for example, and which is available in thicknesses between 30  $\mu\text{m}$  and 1.1 mm is especially suitable as the optical conduction layer because of its high optical quality.

Essentially the thin glass layer may remain unstructured, then forming a single, continuous, cohesive optical layer. Another preferred embodiment of the circuitboard according to this invention, however, is characterized in that at least individual thin glass layers are structured in such a way as to form individual optical conductors within the layer, separated from one another by interspaces. In this way, a variety of independent optical conductors can be produced in one level and can assume different transmission functions without causing any mutual interference.

The optical properties of the individual optical conductors can be optimized either by covering the exposed surfaces of the individual optical conductors with a reflective layer or by filling the interspaces between the optical conductors with a filling material which has a lower refractive index than the refractive index of the glass of the thin glass layer in particular.

Another preferred embodiment of the circuitboard according to this

invention is characterized in that coupling openings are provided for optical coupling of optically active elements arranged on the top and/or bottom sides of the circuitboard, so that the concealed thin glass layer or optical conductors inside an optical conduction level is/are accessible from the outside.

The method according to this invention for producing a circuitboard is characterized in that in a first step, at least one thin glass layer is joined to at least one carrier plate over the entire area to form an optical sandwich, and in a second step the optical sandwich is connected to the circuitboard as an optical conduction level having one or more electrical conduction levels in a stack arrangement, with the thin glass layer and the carrier plate preferably being joined together by pressing and/or gluing.

Additional embodiments are derived from the dependent claims.

#### BRIEF EXPLANATION OF THE FIGURES

This invention will now be explained in greater detail below on the basis of embodiments in conjunction with the drawings, which show:

Fig. 1A-D various stages in the production of an „optical sandwich“ with a structured thin glass layer according to a preferred embodiment of this invention, shown in a perspective, partially cut-away view;

Fig. 2 an alternative embodiment to Figure 1D with a thin glass layer between two carrier plates;

Fig. 3 an alternative embodiment to Figure 1D with two thin glass layers arranged one above the other on one side of the carrier plates;

Fig. 4 an alternative embodiment to Figure 1D with two thin glass layers on opposite sides of the carrier plate;

Fig. 5 an enlarged sectional diagram of the optical sandwich according to Figure 1D with the interspaces of the structured thin glass

layer filled by an optically adapted filling material;

Fig. 6 an alternative embodiment to Figure 5B with a cover over the structured thin glass layer formed by a reflective layer; and

Fig. 7 an embodiment of a circuitboard according to this invention with three optical conduction levels (sandwiches) according to Figure 2, separated from one another by two electrical conduction levels arranged between them.

### METHODS OF EMBODYING THIS INVENTION

In production of the circuitboard according to this invention, individual so-called „optical sandwiches“ are produced first, to form the optical conduction level in a future circuitboard. The optical sandwich is produced in several steps which are shown as an example in Figure 1A-1D, starting with a carrier plate 10 (Figure 1A), which has planer surfaces on the top and bottom sides and is made of an electrically insulating material such as that used for the production of electrical circuitboards. This ensures that the finished optical sandwich can be integrated well into existing circuitboard processes from the standpoint of its material properties. The material used for this is preferably an Aramid-reinforced resin. Such carrier plates are available under the brand name Duramid-P-Cu 115ML from the German company Isola, for example. However, any other insulation material having isotropic properties and a coefficient of expansion like that of glass can also be used. The thickness of carrier plate 10 is selected so that carrier plate 10 imparts a sufficient mechanical stability to the optical sandwich, but on the other hand does not take up an unnecessary amount of height in subsequent integration into the circuitboard.

Carrier plate 10 is then joined to a thin glass layer 11 by pressing or gluing over the entire area according to Figure 1B. The thin glass layer 11 is preferably made of a borosilicate glass and has a thickness of less than or equal to 1.1 mm (30  $\mu\text{m}$  to 1.1 mm). Thin glass of this type is available under the brand names AF 45 and D 263 from the German company DESAG, for example. Thin glass AF 45 is a modified borosilicate glass

with a high BaO and Al<sub>2</sub>O<sub>3</sub> content and is characterized by a low thermal expansion coefficient and a high light transmission value. Due to low tolerances and flame-polished surfaces, this type of glass is especially suitable for large-area optical applications such as LCD displays, covers for CCD elements, solar cells or the like. Thin glass D 263 is a borosilicate glass with corresponding optical properties. Both of these thin glasses are available in a thickness in the range between 30 μm to 1.1 mm.

If the optical conduction level is provided only as a common databus in the subsequent circuitboard, then an optical sandwich can be integrated directly into the circuitboard with an unstructured thin glass layer according to Figure 1B (see Figure 7). However, if individual optical conduction connections are needed between different points in the plate, the thin glass layer is then structured according to Figure 1C after creation of the optical sandwich by completely removing the thin glass layer in certain areas to form interspaces 12 between individual optical conductors 13. The individual optical conductors 13 may have different areas (as shown in Figure 1C). They may run parallel to one another and may have the same or different lengths, but they may also be bent or shaped in some other manner in as much as this is consistent with their function as an optical conductor. Interspaces 12 can be created by different techniques. A mechanical method of production by grinding or milling is conceivable, but removal by means of a laser or by chemical methods is also conceivable.

After the thin glass layer 1 has been structured, the resulting interspaces 13 are filled with a filling material 14 to complete the optical sandwich 15 (Figure 1B and Figure 5). This filling operation has the advantage that a mechanically stable planer surface is formed on the top side of thin glass layer 11. On the other hand, if filling material 14 has a refractive index lower than the refractive index of the glass of thin glass layer 11, then this filling material ensures total reflection in optical conductors 13 and thus ensures good optical conduction properties. However, the same good optical conduction properties can also be achieved if the free surfaces of the structured thin glass layer 11 or the optical conductor 13 are coated with a preferably metallic reflective layer 29 by vapor deposition or by galvanic or chemical deposition in optical sandwich 15.4, as illustrated in

Figure 6. Again in this case, the remaining interspaces may be filled subsequently with a filling material for mechanical reasons.

Instead of the optical sandwich 15 from Figure 1B composed of two layers 10 and 11, optical sandwiches comprising more than two layers may also be used. In the case of optical sandwich 15.1 from Figure 2, the thin glass layer 11 is joined to carrier plates 10 and 16 on both sides. This further increases its mechanical stability. At the same time, optical sandwich 15.1 has the circuitboard material of carrier plates 10 and 16 as the connecting surface on the top and bottom sides and therefore it can be integrated especially well into the circuitboard manufacturing process.

In the case of the optical sandwich 15.2 from Figure 3, a second structured thin glass layer 17 is arranged above the first structured thin glass layer 11 and forms a second optical conduction level and thus provides additional optical connections within the circuitboard without taking up much space. In the case of the second thin glass layer 17, the interspaces are preferably also filled by a filling material 18.

Finally, in the case of the optical sandwich 15.3 from Figure 4, a structured thin glass layer 11 and 17 is provided with interspaces filled with filling material 14 and 18 on the opposite sides of carrier plate 10, thus providing a clear separation between thin glass layers 11 and 17. It is self-evident that other combinations of thin glass layers and carrier plates are also conceivable within the scope of this invention.

The finished optical sandwiches 15 and 15.1 through 15.4 can then be combined in a stack with traditional electric circuitboards that are metallized on both sides and connected to form a finished circuitboard for optical and electrical signals. The mechanical stability of these sandwiches permits problem-free integration into the production process. One such circuitboard 30 shown as an example has three optical conduction levels and two electrical conduction levels, as illustrated in a sectional view in Figure 7. The (three) optical conduction levels OL of the circuitboard 30 are formed by three optical sandwiches 15.1 according to Figure 2. Two electrical conduction levels EL are arranged in alternation between the optical conduction levels OL, each consisting of a dielectric

layer 19 and 20 in a traditional manner, coated on both sides with a metal layer 21, 22 and 23, 24 (e.g., copper lamination). All the layers are pressed or glued together. Both the thin glass layers of optical conduction levels OL and the metal layers of electrical conduction levels EL are structured according to the requirements of circuitboard 30, where the structuring of electrical conduction levels EL is accomplished in a known manner (e.g., by etching the metal layers 21-24); structuring of metal layers 21-24 is not illustrated in Figure 7 for the sake of simplicity. Of course, through-contacts such as those known and conventionally used in the technology of multilayer circuitboards may also be provided between electrical conduction levels EL.

If optically active elements or chips 25, 27 are to be connected to each other or to optical inputs or outputs, plug connections or the like through the optical conduction levels OL, then coupling openings 26, 28 are introduced into the circuitboard 30 for optical coupling of the elements 25, 27 arranged on the top and/or bottom sides of the circuitboard 30, these coupling openings providing access from the outside to thin glass layers 11 and optical conductors 13 which are concealed and lie in an optical conduction level OL. Accordingly, purely electronic chips which are arranged on the circuitboard can be connected to electric conduction levels EL by means of through-contacts (not shown in Figure 7).

LIST OF REFERENCE NOTATION

10, 16	carrier plate
11, 17	thin glass layer
12	interspace
13	optical conductor
14, 18	filling material
15; 15.1-15.3	optical sandwich
19, 20	dielectric layer
21-24	metal layer (e.g., Cu)
25, 27	optically active element (optical chip)
26, 28	coupling opening
29	reflective layer
30	circuitboard
EL	electrical conduction level
OL	optical conduction level

CLAIMS

1. The circuitboard (30) having at least one electrical conduction level (EL) for relaying electrical signals and/or currents as well as at least one optical conduction level (OL) for relaying optical signals, said conduction levels (EL, OL) being interconnected and arranged in a stack one above the other within the circuitboard, characterized in that the optical conduction level (OL) as a conducting element comprises at least one thin glass layer (11, 17).
2. A circuitboard according to claim 1, characterized in that the optical conduction level (OL) is formed by an optical sandwich (15; 15.1, ..., 15.3) comprising, in addition to the minimum of one thin glass layer (11, 17), at least one carrier plate (10, 16) which is joined to the minimum of one thin glass layer (11, 17) over the area.
3. A circuitboard according to claim 2, characterized in that the optical sandwich (15.1) comprises at least two carrier plates (10, 16) with a minimum of one thin glass layer (11) arranged between them.
4. A circuitboard according to claim 2, characterized in that the optical sandwich (15.2, 15.3) comprises at least two thin glass layers (11, 17) which are joined over the area to the minimum of one carrier plate (10).
5. A circuitboard according to claim 4, characterized in that the minimum of two thin glass layers (11, 17) are joined together over the area and are arranged on one side of the minimum of one carrier plate (10).
6. A circuitboard according to claim 4, characterized in that the minimum of two thin glass layers (11, 17) are arranged on opposite sides of the minimum of one carrier plate (10).
7. A circuitboard according to one of claims 2-6, characterized in that the carrier plates (10, 16) are each made of an electrically insulating material which is used as the base material for the



production of electric circuitboards, preferably an Aramid-reinforced resin.

8. A circuitboard according to one of claims 1-7, characterized in that the thin glass layers (11, 17) have a thickness of less than or equal to 1.1 mm and are made of a borosilicate glass.
9. A circuitboard according to one of claims 1-8, characterized in that the thin glass layers (11, 17) and the carrier plates (10, 16) are glued or pressed together.
10. A circuitboard according to one of claims 1-9, characterized in that at least individual layers of the thin glass layers (11, 17) are designed as continuous layers.
11. A circuitboard according to one of claims 1-9, characterized in that at least individual layers of the thin glass layers (11, 17) are structured so as to form individual optical conductors (13) within the layer, separated from one another by interspaces (12).
12. A circuitboard according to claim 11, characterized in that the exposed surfaces of the individual optical conductors (13) are covered with a reflective layer (29).
13. A circuitboard according to one of claims 11 and 12, characterized in that the interspaces (12) between the optical conductors (13) are filled with a filling material (14, 18).
14. A circuitboard according to one of claims 1-13, characterized in that coupling openings (26, 28) are provided for optical coupling of optically active elements (25, 27) arranged on the top and or bottom sides of the circuitboard (30), so that the concealed thin glass layer(s) (11, 17) or optical conductors (13) located in an optical conduction level (OL) are accessible from the outside through these coupling openings.
15. A method of producing a circuitboard according to one of claims 1

through 14, characterized in that in a first step at least one thin glass layer (11, 17) is joined over the entire area to at least one carrier plate (10, 16) to form an optical sandwich (15; 15.1, ..., 15.3), and in a second step, the optical sandwich (15; 15.1, ..., 15.3) is connected to the circuitboard (30) as an optical conduction level (OL) having one or more electrical conduction levels (EL) in a stack arrangement.

16. A method according to claim 15, characterized in that the thin glass layer (11, 17) and the carrier plate (10, 16) are joined together by pressing or gluing.
17. A method according to one of claims 15 and 16, characterized in that the thin glass layer (11, 17) joined to the carrier plate (10, 16) is structured between the first and second steps.
18. A method according to claim 17, characterized in that the thin glass layer is removed in certain predetermined areas in order to structure the thin glass layer (11, 17) to form individual optical conductors (13) separated from one another by interspaces (12).
19. A method according to claim 18, characterized in that the removal of the thin glass layer (11, 17) is accomplished by means of lasers or by mechanical or chemical methods.
20. A method according to one of claims 17 through 19, characterized in that the free surface area of the structured thin glass layer (11) is coated with a reflective layer (29), preferably made of a metal, by vapor deposition, galvanic or chemical deposition.
21. A method according to one of claims 17 through 20, characterized in that the interspaces (12) in the structured thin glass layer (11, 17) are filled with a filling material (14, 18) having a refractive index lower than the refractive index of the glass of the thin glass layer (11, 17).

# INTERNATIONAL SEARCH REPORT

International Application No  
PCT/CH 00/00056

**A. CLASSIFICATION OF SUBJECT MATTER**  
IPC 7 G02B6/43 G02B6/13

According to International Patent Classification (IPC) or to both national classification and IPC

**B. FIELDS SEARCHED**

Minimum documentation searched (classification system followed by classification symbols)  
IPC 7 G02B

Documentation searched other than minimum documentation to the extent that such documents are included in the fields searched

Electronic data base consulted during the international search (name of data base and, where practical, search terms used)

**C. DOCUMENTS CONSIDERED TO BE RELEVANT**

Category *	Citation of document, with indication, where appropriate, of the relevant passages	Relevant to claim No.
X	WO 90 01176 A (KONECHNY EDWARD THOMAS JR) 8 February 1990 (1990-02-08)  abstract; figures 1-3,5 page 6, line 5 - line 27 page 9, paragraph 1	1-7, 10, 11, 14, 15, 17-19
A	----	8, 12, 20, 21
A	EP 0 581 012 A (MOTOROLA INC) 2 February 1994 (1994-02-02) column 4, line 47 - line 55	1, 9, 13, 15, 16
A	US 5 249 245 A (LEBBY MICHAEL S ET AL) 28 September 1993 (1993-09-28) abstract; figures 1,3	1-22

Further documents are listed in the continuation of box C.

Patent family members are listed in annex.

\* Special categories of cited documents :

- "A" document defining the general state of the art which is not considered to be of particular relevance
- "E" earlier document but published on or after the international filing date
- "L" document which may throw doubts on priority claim(s) or which is cited to establish the publication date of another citation or other special reason (as specified)
- "O" document referring to an oral disclosure, use, exhibition or other means
- "P" document published prior to the international filing date but later than the priority date claimed

- "T" later document published after the international filing date or priority date and not in conflict with the application but cited to understand the principle or theory underlying the invention
- "X" document of particular relevance; the claimed invention cannot be considered novel or cannot be considered to involve an inventive step when the document is taken alone
- "Y" document of particular relevance; the claimed invention cannot be considered to involve an inventive step when the document is combined with one or more other such documents, such combination being obvious to a person skilled in the art.
- "&" document member of the same patent family

Date of the actual completion of the international search

18 April 2000

Date of mailing of the international search report

28/04/2000

Name and mailing address of the ISA

European Patent Office, P.B. 5818 Patentlaan 2  
NL - 2280 HV Rijswijk  
Tel. (+31-70) 340-2040, Tx. 31 651 epo nl,  
Fax: (+31-70) 340-3016

Authorized officer

Jakober, F

# INTERNATIONAL SEARCH REPORT

Information on patent family members

International Application No

PCT/CH 00/00056

Patent document cited in search report	Publication date	Patent family member(s)	Publication date
WO 9001176    A	08-02-1990	US 4758063 A	19-07-1988
EP 0581012    A	02-02-1994	US 5271083 A	14-12-1993
		DE 69321416 D	12-11-1998
		DE 69321416 T	29-04-1999
		JP 6067050 A	11-03-1994
US 5249245    A	28-09-1993	NONE	