



(51) International Patent Classification:
F25J 1/00 (2006.01) *F25J 1/02* (2006.01)

(72) Inventors: **LIU, Yijun**; 1211 Melford Drive, Houston, TX 77077 (US). **PIERRE, Fritz Jr.**; 18011 Bayou Mead Trail, Humble, TX 77346 (US).

(21) International Application Number:
PCT/US2019/032013

(74) Agent: **JENSEN, Nathan, O.** et al.; ExxonMobil Upstream Research Company, (EMHC-N1-4A-607), 22777 Springwoods Village Parkway, Spring, TX 77389 (US).

(22) International Filing Date:
13 May 2019 (13.05.2019)

(25) Filing Language: English

(81) Designated States (unless otherwise indicated, for every kind of national protection available): AE, AG, AL, AM, AO, AT, AU, AZ, BA, BB, BG, BH, BN, BR, BW, BY, BZ, CA, CH, CL, CN, CO, CR, CU, CZ, DE, DJ, DK, DM, DO, DZ, EC, EE, EG, ES, FI, GB, GD, GE, GH, GM, GT, HN, HR, HU, ID, IL, IN, IR, IS, JO, JP, KE, KG, KH, KN, KP, KR, KW, KZ, LA, LC, LK, LR, LS, LU, LY, MA, MD, ME, MG, MK, MN, MW, MX, MY, MZ, NA, NG, NI, NO, NZ, OM, PA, PE, PG, PH, PL, PT, QA, RO, RS, RU, RW, SA, SC, SD, SE, SG, SK, SL, SM, ST, SV, SY, TH, TJ, TM, TN, TR, TT, TZ, UA, UG, US, UZ, VC, VN, ZA, ZM, ZW.

(26) Publication Language: English

(30) Priority Data:
62/681,938 07 June 2018 (07.06.2018) US

(71) Applicant: **EXXONMOBIL UPSTREAM RESEARCH COMPANY** [US/US]; (EMHC-N1-4A-607), 22777 Springwoods Village Parkway, Spring, TX 77389 (US).

(54) Title: PRETREATMENT AND PRE-COOLING OF NATURAL GAS BY HIGH PRESSURE COMPRESSION AND EXPANSION

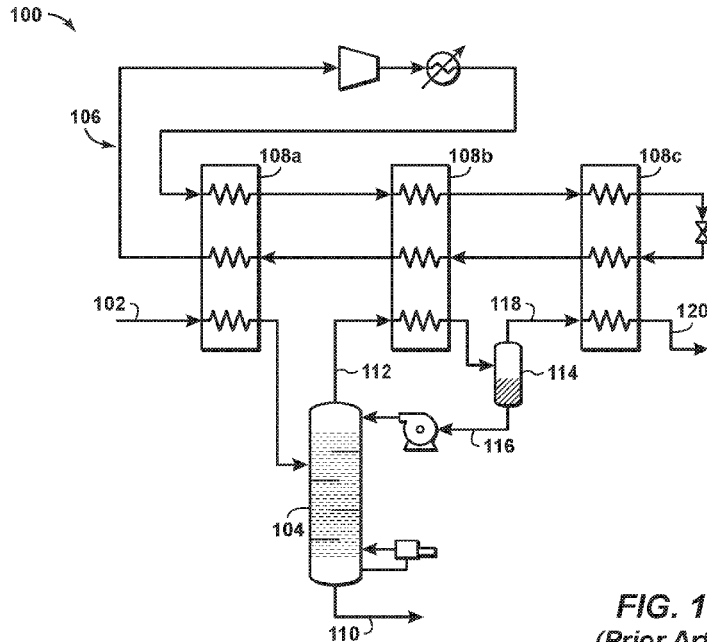

FIG. 1
(Prior Art)

(57) Abstract: A method and apparatus for producing liquefied natural gas. A pretreated natural gas stream is compressed in at least two serially arranged compressors to a pressure of at least 1,500 psia and cooled. The resultant cooled compressed natural gas stream is expanded in at least one work producing natural gas expander to a pressure less than 2,000 psia and no greater than the pressure to which natural gas stream has been compressed, thereby forming a chilled natural gas stream that is separated into a refrigerant stream and a non-refrigerant stream. The refrigerant stream is warmed in a heat exchanger through heat exchange with one or more process streams associated with pretreating the natural gas stream, thereby generating a warmed refrigerant stream. The warmed refrigerant stream and the non-refrigerant stream are then liquefied.



(84) **Designated States** (*unless otherwise indicated, for every kind of regional protection available*): ARIPO (BW, GH, GM, KE, LR, LS, MW, MZ, NA, RW, SD, SL, ST, SZ, TZ, UG, ZM, ZW), Eurasian (AM, AZ, BY, KG, KZ, RU, TJ, TM), European (AL, AT, BE, BG, CH, CY, CZ, DE, DK, EE, ES, FI, FR, GB, GR, HR, HU, IE, IS, IT, LT, LU, LV, MC, MK, MT, NL, NO, PL, PT, RO, RS, SE, SI, SK, SM, TR), OAPI (BF, BJ, CF, CG, CI, CM, GA, GN, GQ, GW, KM, ML, MR, NE, SN, TD, TG).

Declarations under Rule 4.17:

- *as to applicant's entitlement to apply for and be granted a patent (Rule 4.17(ii))*
- *as to the applicant's entitlement to claim the priority of the earlier application (Rule 4.17(iii))*

Published:

- *with international search report (Art. 21(3))*

PRETREATMENT AND PRE-COOLING OF NATURAL GAS BY HIGH PRESSURE COMPRESSION AND EXPANSION

CROSS REFERENCE TO RELATED APPLICATIONS

5 [0001] This application claims the priority benefit of United States Provisional Patent Application No. 62/681,938 filed June 7, 2018, entitled PRETREATMENT AND PRE-COOLING OF NATURAL GAS BY HIGH PRESSURE COMPRESSION AND EXPANSION. This application is related to U.S. Patent Application No. 15/348,533, Filed November 10, 2016, and entitled PRE-COOLING OF NATURAL GAS BY HIGH
10 PRESSURE COMPRESSION AND EXPANSION, the entirety of which is incorporated by reference herein.

FIELD OF THE INVENTION

[0002] The invention relates to the liquefaction of natural gas to form liquefied natural gas (LNG), and more specifically, to the production of LNG in remote or sensitive areas where the
15 construction and/or maintenance of capital facilities, and/or the environmental impact of a conventional LNG plant may be detrimental.

BACKGROUND

[0003] LNG production is a rapidly growing means to supply natural gas from locations with an abundant supply of natural gas to distant locations with a strong demand for natural
20 gas. The conventional LNG production cycle includes: a) initial treatments of the natural gas resource to remove contaminants such as water, sulfur compounds and carbon dioxide; b) the separation of some heavier hydrocarbon gases, such as propane, butane, pentane, etc. by a variety of possible methods including self-refrigeration, external refrigeration, lean oil, etc.; c) refrigeration of the natural gas substantially by external refrigeration to form liquefied natural
25 gas at near atmospheric pressure and about -160 °C; d) transport of the LNG product in ships or tankers designed for this purpose to a market location; e) re-pressurization and regasification of the LNG at a regasification plant to a pressurized natural gas that may distributed to natural gas consumers. Step (c) of the conventional LNG cycle usually requires the use of large refrigeration compressors often powered by large gas turbine drivers that emit substantial
30 carbon and other emissions. Large capital investment in the billions of US dollars and extensive infrastructure are required as part of the liquefaction plant. Step (e) of the

conventional LNG cycle generally includes re-pressurizing the LNG to the required pressure using cryogenic pumps and then re-gasifying the LNG to pressurized natural gas by exchanging heat through an intermediate fluid but ultimately with seawater or by combusting a portion of the natural gas to heat and vaporize the LNG.

5 [0004] Although LNG production in general is well known, technology improvements may still provide an LNG producer with significant opportunities as it seeks to maintain its leading position in the LNG industry. For example, floating LNG (FLNG) is a relatively new technology option for producing LNG. The technology involves the construction of the gas treating and liquefaction facility on a floating structure such as barge or a ship. FLNG is a
10 technology solution for monetizing offshore stranded gas where it is not economically viable to construct a gas pipeline to shore. FLNG is also increasingly being considered for onshore and near-shore gas fields located in remote, environmentally sensitive and/or politically challenging regions. The technology has certain advantages over conventional onshore LNG in that it has a reduced environmental footprint at the production site. The technology may
15 also deliver projects faster and at a lower cost since the bulk of the LNG facility is constructed in shipyards with lower labor rates and reduced execution risk.

[0005] Although FLNG has several advantageous over conventional onshore LNG, significant technical challenges remain in the application of the technology. For example, the FLNG structure must provide the same level of gas treating and liquefaction in an area or space
20 that is often less than one quarter of what would be available for an onshore LNG plant. For this reason, there is a need to develop technology that reduces the footprint of the liquefaction facility while maintaining its capacity to thereby reduce overall project cost. Several liquefaction technologies have been proposed for use on an FLNG project. The leading technologies include a single mixed refrigerant (SMR) process, a dual mixed refrigerant
25 (DMR) process, and expander-based (or expansion) process.

[0006] In contrast to the DMR process, the SMR process has the advantage of allowing all the equipment and bulks associated with the complete liquefaction process to fit within a single FLNG module. The SMR liquefaction module is placed on the topside of the FLNG structure as a complete SMR train. This “LNG-in-a-Box” concept is favorable for FLNG project
30 execution because it allows for the testing and commissioning of the SMR train at a different location from where the FLNG structure is constructed. It may also allow for the reduction in labor cost since it reduces labor hours at ship yards where labor rates tend to be higher than labor rates at conventional fabrication yards. The SMR process has the added advantage of

being a relatively efficient, simple, and compact refrigerant process when compared to other mixed refrigerant processes. Furthermore, the SMR liquefaction process is typically 15% to 20% more efficient than expander-based liquefaction processes.

[0007] The choice of the SMR process for LNG liquefaction in an FLNG project has its advantages; however, there are several disadvantages to the SMR process. For example, the required use and storage of combustible refrigerants such as propane significantly increases loss prevention issues on the FLNG. The SMR process is also limited in capacity, which increases the number of trains needed to reach the desired LNG production. Also, to remove heavy hydrocarbons and recover the necessary natural gas liquids for refrigerant makeup, a scrub column is often used. **Figure 1** illustrates a typical LNG liquefaction system **100** integrating a simple SMR process with a scrub column **104**. A SMR refrigerant loop **106** cools and liquefies a feed gas stream **102** in one or more heat exchangers **108a**, **108b**, **108c**. Specifically, the SMR refrigerant loop **106** cools the feed gas stream **102** before it is sent to the scrub column **104**. Heavy hydrocarbons are removed from a bottom stream **110** of the scrub column **104**, and a cooled vapor stream **112** is removed from the top of the scrub column **104**. The cooled vapor stream **112** is then cooled and partially condensed in heat exchanger **108b** through heat exchange with the SMR refrigerant loop **106**. The cooled vapor stream is sent to a separating vessel **114**, where the condensed portion of the cooled vapor stream is returned to the scrub column as a liquid reflux stream **116**, and the vapor portion **118** of the cooled vapor stream is liquefied through heat exchange with the SMR refrigerant loop **106** in the heat exchanger **108c**. An LNG stream **120** exits the LNG liquefaction system **100** for storage and/or transport.

[0008] The integrated scrub column design, such as the one depicted in **Figure 1** and described above, is usually the lowest cost option for heavy hydrocarbon removal. However, this design has the disadvantage of reducing train capacity because some of the refrigeration of the SMR train is used in heat exchanger **108b** to produce the column reflux. It also has the disadvantage of increasing the equipment count of an SMR train, which may limit the ability to place the SMR train within a single FLNG module. Furthermore, for FLNG applications of greater than 1.5 MTA, multiple SMR trains are required, with each train having its own integrated scrub column. For these reasons and others, a significant amount of topside space and weight is required for the SMR trains. Since topside space and weight are significant drivers for FLNG project cost, there remains a need to improve the SMR liquefaction process to further reduce topside space, weight and complexity to thereby improve project economics.

There remains an additional need to develop a heavy hydrocarbon removal process capable of increasing train capacity while also reducing overall equipment count for high production FLNG applications.

[0009] The expander-based process has several advantages that make it well suited for FLNG projects. The most significant advantage is that the technology offers liquefaction without the need for external hydrocarbon refrigerants. Removing liquid hydrocarbon refrigerant inventory, such as propane storage, significantly reduces safety concerns on FLNG projects. An additional advantage of the expander-based process compared to a mixed refrigerant process is that the expander-based process is less sensitive to offshore motions since the main refrigerant mostly remains in the gas phase. However, application of the expander-based process to an FLNG project with LNG production of greater than 2 million tons per year (MTA) has proven to be less appealing than the use of the mixed refrigerant process. The capacity of an expander-based process train is typically less than 1.5 MTA. In contrast, a mixed refrigerant process train, such as that of known dual mixed refrigerant processes, can have a train capacity of greater than 5 MTA. The size of the expander-based process train is limited since its refrigerant mostly remains in the vapor state throughout the entire process and the refrigerant absorbs energy through its sensible heat. For these reasons, the refrigerant volumetric flow rate is large throughout the process, and the size of the heat exchangers and piping are proportionately greater than those of a mixed refrigerant process. Furthermore, the limitations in compressor horsepower size results in parallel rotating machinery as the capacity of the expander-based process train increases. The production rate of an FLNG project using an expander-based process can be made to be greater than 2 MTA if multiple expander-based trains are allowed. For example, for a 6 MTA FLNG project, six or more parallel expander-based process trains may be sufficient to achieve the required production. However, the equipment count, complexity and cost all increase with multiple expander trains. Additionally, the assumed process simplicity of the expander-based process compared to a mixed refrigerant process begins to be questioned if multiple trains are required for the expander-based process while the mixed refrigerant process can obtain the required production rate with one or two trains. An integrated scrub column design may also be used to remove heavy hydrocarbons for an expander-based liquefaction process. The advantages and disadvantages of its use is similar to that of an SMR process. The use of an integrated scrub column design limits the liquefaction pressure to a value below the cricondenbar of the feed gas. This fact is a particular disadvantage for expander-based processes since its process efficiency is more negatively impacted by lower

liquefaction pressures than mixed refrigerant processes. For these reasons, there is a need to develop a high LNG production capacity FLNG liquefaction process with the advantages of an expander-based process. There is a further need to develop an FLNG technology solution that is better able to handle the challenges that vessel motion has on gas processing. There remains
5 a further need to develop a heavy hydrocarbon removal process better suited for expander based process by eliminating the efficiency and production loss associated with conventional technologies.

[0010] United States Patent No. 6,412,302 describes a feed gas expander-based process where two independent closed refrigeration loops are used to cool the feed gas to form LNG.
10 In an embodiment, the first closed refrigeration loop uses the feed gas or components of the feed gas as the refrigerant. Nitrogen gas is used as the refrigerant for the second closed refrigeration loop. This technology requires smaller equipment and topside space than a dual loop nitrogen expander-based process. For example, the volumetric flow rate of the refrigerant into the low pressure compressor can be 20 to 50% smaller for this technology compared to a
15 dual loop nitrogen expander-based process. The technology, however, is still limited to a capacity of less than 1.5 MTA.

[0011] United States Patent No. 8,616,012 describes a feed gas expander-based process where feed gas is used as the refrigerant in a closed refrigeration loop. Within this closed refrigeration loop, the refrigerant is compressed to a pressure greater than or equal to 1,500
20 psia (10,340 kPa), or more preferably greater than 2,500 psia (17,240 kPa). The refrigerant is then cooled and expanded to achieve cryogenic temperatures. This cooled refrigerant is used in a heat exchanger to cool the feed gas from warm temperatures to cryogenic temperatures. A subcooling refrigeration loop is then employed to further cool the feed gas to form LNG. In one embodiment, the subcooling refrigeration loop is a closed loop with flash gas used as the
25 refrigerant. This feed gas expander-based process has the advantage of not being limited to a train capacity range of less than 1 MTA. A train size of approximately 6 MTA has been considered. However, the technology has the disadvantage of an increased equipment count and increased complexity due to its requirement for two independent refrigeration loops and the compression of the feed gas.

[0012] GB 2,486,036 describes a feed gas expander-based process that is an open loop refrigeration cycle including a pre-cooling expander loop and a liquefying expander loop, where the gas phase after expansion is used to liquefy the natural gas. According to this
30 document, including a liquefying expander in the process significantly reduces the recycle gas

rate and the overall required refrigeration power. This technology has the advantage of being simpler than other technologies since only one type of refrigerant is used with a single compression string. However, the technology is still limited to capacity of less than 1.5 MTA and it requires the use of liquefying expander, which is not standard equipment for LNG
5 production. The technology has also been shown to be less efficient than other technologies for the liquefaction of lean natural gas.

[0013] United States Patent No. 7,386,996 describes an expander-based process with a pre-cooling refrigeration process preceding the main expander-based cooling circuit. The pre-cooling refrigeration process includes a carbon dioxide refrigeration circuit in a cascade
10 arrangement. The carbon dioxide refrigeration circuit may cool the feed gas and the refrigerant gases of the main expander-based cooling circuit at three pressure levels: a high pressure level to provide the warm-end cooling; a medium pressure level to provide the intermediate temperature cooling; and a low pressure level to provide cold-end cooling for the carbon dioxide refrigeration circuit. This technology is more efficient and has a higher production
15 capacity than expander-based processes lacking a pre-cooling step. The technology has the additional advantage for FLNG applications since the pre-cooling refrigeration cycle uses carbon dioxide as the refrigerant instead of hydrocarbon refrigerants. The carbon dioxide refrigeration circuit, however, comes at the cost of added complexity to the liquefaction process since an additional refrigerant and a substantial amount of extra equipment is introduced. In
20 an FLNG application, the carbon dioxide refrigeration circuit may be in its own module and sized to provide the pre-cooling for multiple expander-based processes. This arrangement has the disadvantage of requiring a significant amount of pipe connections between the pre-cooling module and the main expander-based process modules. The “LNG-in-a-Box” advantages discussed above are no longer realized.

[0014] Thus, there remains a need to develop a pre-cooling process that does not require
25 additional refrigerant and does not introduce a significant amount of extra equipment to the LNG liquefaction process. There is an additional need to develop a pre-cooling process that can be placed in the same module as the liquefaction module. Furthermore, there is an additional need to develop a pre-cooling process that can easily integrate with a heavy
30 hydrocarbon removal process and provide auxiliary cooling upstream of liquefaction. Such a pre-cooling process combined with an SMR process or an expander-based process would be particularly suitable for FLNG applications where topside space and weight significantly impacts the project economics. There remains a specific need to develop an LNG production

process with the advantages of an expander-based process and which, in addition, has a high LNG production capacity without significantly increasing facility footprint. There is a further need to develop an LNG technology solution that is better able to handle the challenges that vessel motion has on gas processing. Such a high capacity expander-based liquefaction process would be particularly suitable for FLNG applications where the inherent safety and simplicity of expander-based liquefaction process are greatly valued.

SUMMARY OF THE INVENTION

[0015] The invention provides a method of producing liquefied natural gas from a natural gas stream. Heavy hydrocarbons are removed from the natural gas stream to thereby generate a separated natural gas stream. The separated natural gas stream is partially condensed in a first heat exchanger to thereby generate a partially condensed natural gas stream. Liquids are separated from the partially condensed natural gas stream to thereby generate a pretreated natural gas stream. The pretreated natural gas stream is compressed in at least two serially arranged compressors to a pressure of at least 1,500 psia to form a compressed natural gas stream, which is cooled to form a cooled compressed natural gas stream. The cooled compressed natural gas stream is expanded in at least one work producing natural gas expander to a pressure that is less than 2,000 psia and no greater than the pressure to which the at least two serially arranged compressors compress the pretreated natural gas stream, to thereby form a chilled natural gas stream. The chilled natural gas stream is separated into a refrigerant stream and a non-refrigerant stream. The refrigerant is warmed stream through heat exchange with one or more process streams comprising the natural gas stream, the separated natural gas stream, the partially condensed natural gas stream, and the pretreated natural gas stream, thereby generating a warmed refrigerant stream. The warmed refrigerant stream and the non-refrigerant stream are then liquefied.

[0016] The invention also provides an apparatus for the liquefaction of natural gas. A first separation device is configured to remove heavy hydrocarbons from a natural gas stream to thereby generate a separated natural gas stream. A first heat exchanger partially condenses the separated natural gas stream. A second separation device separates liquids from the partially condensed natural gas stream to thereby generate a liquids stream and a pretreated natural gas stream. At least two serially arranged compressors compress the pretreated natural gas stream to a pressure greater than 1,500 psia, and a cooling element cools the compressed natural gas stream, thereby forming a cooled compressed natural gas stream. At least one work-producing expander expands the cooled compressed natural gas stream to a pressure which is less than

2,000 psia and is no greater than the pressure to which the at least two serially arranged compressors compress the pretreated natural gas stream, to thereby form a chilled natural gas stream. The chilled natural gas stream is separated into a refrigerant stream and a non-refrigerant stream, and the refrigerant stream is warmed through heat exchange in the first heat exchanger with one or more of the natural gas stream, the separated natural gas stream, the partially condensed natural gas stream, the pretreated natural gas stream, and the liquids stream, thereby generating a warmed refrigerant stream. At least one liquefaction train liquefies the warmed refrigerant stream and the non-refrigerant stream.

[0017] The invention also provides a floating LNG structure. A first separation device removes heavy hydrocarbons from a natural gas stream, to thereby generate a separated natural gas stream. A first heat exchanger that partially condenses the separated natural gas stream, and a second separation device separates liquids from the partially condensed natural gas stream, to thereby generate a liquids stream and a pretreated natural gas stream. At least two serially arranged compressors compress the pretreated natural gas stream to a pressure greater than 1,500 psia, and the compressed natural gas stream is cooled. At least one work-producing expander expands the cooled compressed natural gas stream to a pressure less than 2,000 psia and no greater than the pressure to which the at least two serially arranged compressors compress the pretreated natural gas stream, to thereby form a chilled natural gas stream. The chilled natural gas stream is separated into a refrigerant stream and a non-refrigerant stream. The refrigerant stream is warmed through heat exchange in the first heat exchanger with one or more of the natural gas stream, the separated natural gas stream, the partially condensed natural gas stream, the pretreated natural gas stream, and the liquids stream, thereby generating a warmed refrigerant stream. At least one liquefaction train liquefies the warmed refrigerant stream and the non-refrigerant stream.

[0018] The invention further provides a method of producing liquefied natural gas from a natural gas stream. The natural gas stream is pretreated and then compressed in at least two serially arranged compressors to a pressure of at least 1,500 psia to form a compressed natural gas stream. The compressed natural gas stream is cooled and then expanded in at least one work producing natural gas expander to a pressure that is less than 2,000 psia and no greater than the pressure to which the at least two serially arranged compressors compress the pretreated natural gas stream, to thereby form a chilled natural gas stream. The chilled natural gas stream is separated into a refrigerant stream and a non-refrigerant stream. The refrigerant stream is warmed in a heat exchanger through heat exchange with one or more process streams

associated with pretreating the natural gas stream, thereby generating a warmed refrigerant stream. The warmed refrigerant stream and the non-refrigerant stream are then liquefied.

BRIEF DESCRIPTION OF THE FIGURES

[0019] **Figure 1** is a schematic diagram of a SMR process with an integrated scrub column
5 for heavy hydrocarbon removal according to known principles.

[0020] **Figure 2** is a schematic diagram of a high pressure compression and expansion (HPCE) module with heavy hydrocarbon removal according to disclosed aspects.

[0021] **Figure 3** is a schematic diagram showing an arrangement of single-mixed refrigerant (SMR) liquefaction modules according to known principles.

10 [0022] **Figure 4** is a schematic diagram showing an arrangement of SMR liquefaction modules according to disclosed aspects.

[0023] **Figure 5** is a graph showing a heating and cooling curve for an expander-based refrigeration process.

[0024] **Figure 6** is a schematic diagram of an HPCE module with heavy hydrocarbon
15 removal according to disclosed aspects.

[0025] **Figure 7** is a schematic diagram of an HPCE module with heavy hydrocarbon removal and a feed gas expander-based liquefaction module according to disclosed aspects.

[0026] **Figure 8** is a flowchart of a method of liquefying natural gas to form LNG according to disclosed aspects.

20 [0027] **Figure 9** is a flowchart of a method of liquefying natural gas to form LNG according to disclosed aspects.

DETAILED DESCRIPTION

[0028] Various specific aspects, embodiments, and versions will now be described, including definitions adopted herein. Those skilled in the art will appreciate that such aspects,
25 embodiments, and versions are exemplary only, and that the invention can be practiced in other ways. Any reference to the “invention” may refer to one or more, but not necessarily all, of the embodiments defined by the claims. The use of headings is for purposes of convenience only and does not limit the scope of the present invention. For purposes of clarity and brevity, similar reference numbers in the several Figures represent similar items, steps, or structures
30 and may not be described in detail in every Figure.

[0029] All numerical values within the detailed description and the claims herein are modified by “about” or “approximately” the indicated value, and take into account experimental error and variations that would be expected by a person having ordinary skill in the art.

5 [0030] As used herein, the term "compressor" means a machine that increases the pressure of a gas by the application of work. A "compressor" or "refrigerant compressor" includes any unit, device, or apparatus able to increase the pressure of a gas stream. This includes compressors having a single compression process or step, or compressors having multi-stage compressions or steps, or more particularly multi-stage compressors within a single casing or
10 shell. Evaporated streams to be compressed can be provided to a compressor at different pressures. Some stages or steps of a cooling process may involve two or more compressors in parallel, series, or both. The present invention is not limited by the type or arrangement or layout of the compressor or compressors, particularly in any refrigerant circuit.

[0031] As used herein, "cooling" broadly refers to lowering and/or dropping a temperature
15 and/or internal energy of a substance by any suitable, desired, or required amount. Cooling may include a temperature drop of at least about 1 °C, at least about 5 °C, at least about 10 °C, at least about 15 °C, at least about 25 °C, at least about 35 °C, or least about 50 °C, or at least about 75 °C, or at least about 85 °C, or at least about 95 °C, or at least about 100 °C. The cooling may use any suitable heat sink, such as steam generation, hot water heating, cooling
20 water, air, refrigerant, other process streams (integration), and combinations thereof. One or more sources of cooling may be combined and/or cascaded to reach a desired outlet temperature. The cooling step may use a cooling unit with any suitable device and/or equipment. According to some embodiments, cooling may include indirect heat exchange, such as with one or more heat exchangers. In the alternative, the cooling may use evaporative
25 (heat of vaporization) cooling and/or direct heat exchange, such as a liquid sprayed directly into a process stream.

[0032] As used herein, the term “environment” refers to ambient local conditions, e.g., temperatures and pressures, in the vicinity of a process.

[0033] As used herein, the term "expansion device" refers to one or more devices suitable
30 for reducing the pressure of a fluid in a line (for example, a liquid stream, a vapor stream, or a multiphase stream containing both liquid and vapor). Unless a particular type of expansion device is specifically stated, the expansion device may be (1) at least partially by isenthalpic

means, or (2) may be at least partially by isentropic means, or (3) may be a combination of both isentropic means and isenthalpic means. Suitable devices for isenthalpic expansion of natural gas are known in the art and generally include, but are not limited to, manually or automatically, actuated throttling devices such as, for example, valves, control valves, Joule-Thomson (J-T) valves, or venturi devices. Suitable devices for isentropic expansion of natural gas are known in the art and generally include equipment such as expanders or turbo expanders that extract or derive work from such expansion. Suitable devices for isentropic expansion of liquid streams are known in the art and generally include equipment such as expanders, hydraulic expanders, liquid turbines, or turbo expanders that extract or derive work from such expansion. An example of a combination of both isentropic means and isenthalpic means may be a Joule-Thomson valve and a turbo expander in parallel, which provides the capability of using either alone or using both the J-T valve and the turbo expander simultaneously. Isenthalpic or isentropic expansion can be conducted in the all-liquid phase, all-vapor phase, or mixed phases, and can be conducted to facilitate a phase change from a vapor stream or liquid stream to a multiphase stream (a stream having both vapor and liquid phases) or to a single-phase stream different from its initial phase. In the description of the drawings herein, the reference to more than one expansion device in any drawing does not necessarily mean that each expansion device is the same type or size.

[0034] The term "gas" is used interchangeably herein with "vapor," and is defined as a substance or mixture of substances in the gaseous state as distinguished from the liquid or solid state. Likewise, the term "liquid" means a substance or mixture of substances in the liquid state as distinguished from the gas or solid state.

[0035] A "heat exchanger" broadly means any device capable of transferring heat energy or cold energy from one medium to another medium, such as between at least two distinct fluids. Heat exchangers include "direct heat exchangers" and "indirect heat exchangers." Thus, a heat exchanger may be of any suitable design, such as a co-current or counter-current heat exchanger, an indirect heat exchanger (e.g. a spiral wound heat exchanger or a plate-fin heat exchanger such as a brazed aluminum plate fin type), direct contact heat exchanger, shell-and-tube heat exchanger, spiral, hairpin, core, core-and-kettle, printed-circuit, double-pipe or any other type of known heat exchanger. "Heat exchanger" may also refer to any column, tower, unit or other arrangement adapted to allow the passage of one or more streams therethrough, and to affect direct or indirect heat exchange between one or more lines of refrigerant, and one or more feed streams.

[0036] As used herein, the term “heavy hydrocarbons” refers to hydrocarbons having more than four carbon atoms. Principal examples include pentane, hexane and heptane. Other examples include benzene, aromatics, or diamondoids.

[0037] As used herein, the term “indirect heat exchange” means the bringing of two fluids into heat exchange relation without any physical contact or intermixing of the fluids with each other. Core-in-kettle heat exchangers and brazed aluminum plate-fin heat exchangers are examples of equipment that facilitate indirect heat exchange.

[0038] As used herein, the term “natural gas” refers to a multi-component gas obtained from a crude oil well (associated gas) or from a subterranean gas-bearing formation (non-associated gas). The composition and pressure of natural gas can vary significantly. A typical natural gas stream contains methane (C₁) as a significant component. The natural gas stream may also contain ethane (C₂), higher molecular weight hydrocarbons, and one or more acid gases. The natural gas may also contain minor amounts of contaminants such as water, nitrogen, iron sulfide, wax, and crude oil.

[0039] As used herein, the term “separation device” or “separator” refers to any vessel configured to receive a fluid having at least two constituent elements and configured to produce a gaseous stream out of a top portion and a liquid (or bottoms) stream out of the bottom of the vessel. The separation device/separator may include internal contact-enhancing structures (e.g. packing elements, strippers, weir plates, chimneys, etc.), may include one, two, or more sections (e.g. a stripping section and a reboiler section), and/or may include additional inlets and outlets. Exemplary separation devices/separators include bulk fractionators, stripping columns, phase separators, scrub columns, and others.

[0040] As used herein, the term “scrub column” refers to a separation device used for the removal of heavy hydrocarbons from a natural gas stream.

[0041] Certain embodiments and features have been described using a set of numerical upper limits and a set of numerical lower limits. It should be appreciated that ranges from any lower limit to any upper limit are contemplated unless otherwise indicated. All numerical values are “about” or “approximately” the indicated value, and take into account experimental error and variations that would be expected by a person having ordinary skill in the art.

[0042] All patents, test procedures, and other documents cited in this application are fully incorporated by reference to the extent such disclosure is not inconsistent with this application and for all jurisdictions in which such incorporation is permitted.

[0043] Aspects disclosed herein describe a process for pretreating and pre-cooling natural gas to a liquefaction process for the production of LNG by the addition of a high pressure compression and high pressure expansion process prior to liquefying the natural gas. A portion of the compressed and expanded gas is used to cool one or more process streams associated with pretreating the feed gas. More specifically, the invention describes a process where heavy hydrocarbons are removed from a natural gas stream to form a pretreated natural gas stream. The pretreated natural gas is compressed to pressure greater than 1,500 psia (10,340 kPa), or more preferably greater than 3,000 psia (20,680 kPa). The hot compressed gas is cooled by exchanging heat with the environment to form a compressed pretreated gas. The compressed pretreated gas is near-isentropically expanded to a pressure less than 3,000 psia (20,680 kPa), or more preferably to a pressure less than 2,000 psia (13,790 kPa) to form a first chilled pretreated gas, where the pressure of the first chilled pretreated gas is less than the pressure of the compressed pretreated gas. The first chilled pretreated gas is separated into at least one refrigerant stream and a non-refrigerant stream. The at least one refrigerant stream is directed to at least one heat exchanger where it acts to cool a process stream and form a warmed refrigerant stream. The warmed refrigerant stream is mixed with the non-refrigerant stream to form a second chilled pretreated gas. The second chilled pretreated gas may be directed to one or more SMR liquefaction trains, or the second chilled pretreated gas may be directed to one or more expander-based liquefaction trains where the gas is further cooled to form LNG.

[0044] **Figure 2** is an illustration of a pretreatment apparatus **200** for pretreating and pre-cooling a natural gas stream **201**, followed by a high pressure compression and expansion (HPCE) process module **212**. A natural gas stream **201** may flow into a separation device, such as a scrub column **202**, where the natural gas stream **201** is separated into a column overhead stream **203** and a column bottom stream **204**. The column overhead stream **203** may flow through a first heat exchanger **205**, known as a ‘cold box’, where the column overhead stream **203** is partially condensed to form a two-phase stream **206**. The two-phase stream **206** may flow into another separation device, such as a separator **207**, to form cold pretreated gas stream **208** and a liquid stream **209**. The cold pretreated gas stream **208** may flow through the first heat exchanger **205** where the cold pretreated gas stream **208** is warmed by indirectly exchanging heat with the column overhead stream **203**, thereby forming a pretreated natural gas stream **210**. The liquid stream **209** may be pressurized within a pump **211** and then directed to the scrub column **202** as a column reflux stream.

[0045] The HPCE process module **212** may comprise a first compressor **213** which

compresses the pretreated natural gas stream **210** to form an intermediate pressure gas stream **214**. The intermediate pressure gas stream **214** may flow through a second heat exchanger **215** where the intermediate pressure gas stream **214** is cooled by indirectly exchanging heat with the environment to form a cooled intermediate pressure gas stream **216**. The second heat exchanger **215** may be an air cooled heat exchanger or a water cooled heat exchanger. The cooled intermediate pressure gas stream **216** may then be compressed within a second compressor **217** to form a high pressure gas stream **218**. The pressure of the high pressure gas stream **218** may be greater than 1,500 psia (10,340 kPa), or more preferably greater than 3,000 psia (20,680 kPa). The high pressure gas stream **218** may flow through a third heat exchanger **219** where the high pressure gas stream **218** is cooled by indirectly exchanging heat with the environment to form a cooled high pressure gas stream **220**. The third heat exchanger **219** may be an air cooled heat exchanger or a water cooled heat exchanger. The cooled high pressure gas stream **220** may then be expanded within an expander **221** to form a first chilled pretreated gas stream **222**. The pressure of the first chilled pretreated gas stream **222** may be less than 3,000 psia (20,680 kPa), or more preferably less than 2,000 psia (13,790 kPa), and the pressure of the first chilled pretreated gas stream **222** is less than the pressure of the cooled high pressure gas stream **220**. In a preferred aspect, the second compressor **217** may be driven solely by the shaft power produced by the expander **221**, as indicated by the dashed line **223**. The first chilled pretreated gas stream **222** may be separated into a refrigerant stream **224** and a non-refrigerant stream **225**. The refrigerant stream **224** may flow through the first heat exchanger **205** where the refrigerant stream **224** is partially warmed by indirectly exchanging heat with the column overhead stream **203**, thereby forming a warmed refrigerant stream **226**. The warmed refrigerant stream **226** may mix with the non-refrigerant stream **225** to form a second chilled pretreated gas stream **227**. The second chilled pretreated gas stream **227** may then be liquefied in, for example, an SMR liquefaction train **240** through indirect heat exchange with an SMR refrigerant loop **228** in a fourth heat exchanger **229**. The resultant LNG stream **230** may then be stored and/or transported as needed.

[0046] It should be noted that the refrigerant stream **224** may be used to cool or chill any of the process streams associated with the pretreatment apparatus **200**. For example, one or more of the column overhead stream **203**, the two-phase stream **206**, the cold pretreated gas stream **208**, the liquid stream **209**, and the pretreated natural gas stream **210** may be configured to exchange heat with the refrigerant stream **224**. Furthermore, other process streams not associated with the pretreatment apparatus **200** may be cooled through heat exchange with the

refrigerant stream 224. The refrigerant stream 224 may be split into two or more sub-streams that are used to cool various process streams.

[0047] In an aspect, the SMR liquefaction process may be enhanced by the addition of the HPCE process upstream of the SMR liquefaction process. More specifically, in this aspect, pretreated natural gas may be compressed to a pressure greater than 1,500 psia (10,340 kPA), or more preferably greater than 3,000 psia (20,680 kPA). The hot compressed gas is then cooled by exchanging heat with the environment to form a compressed pretreated gas. The compressed pretreated gas is then near-isentropically expanded to pressure less than 3,000 psia (20,680 kPA), or more preferably to a pressure less than 2,000 psia (13,790 kPA) to form a first chilled pretreated gas, where the pressure of the first chilled pretreated gas is less than the pressure of the compressed pretreated gas. The first chilled pretreated gas stream is separated into a refrigerant stream and a non-refrigerant stream. The refrigerant stream is warmed by exchanging heat with a column overhead stream in order to help partially condense the column overhead stream and produce a warmed refrigerant stream. The warmed refrigerant stream is mixed with the non-refrigerant stream to produce a second chilled pretreated gas. The second chilled pretreated gas may then be directed to multiple SMR liquefaction trains, arranged in parallel, where the chilled pretreated gas is further cooled therein to form LNG.

[0048] The combination of the HPCE process with pretreatment of the natural gas and liquefaction within multiple SMR liquefaction trains has several advantages over the conventional SMR process where natural gas is sent directly to the SMR liquefaction trains for both heavy hydrocarbon removal (final pretreatment step) and liquefaction. For example, the pre-cooling of the natural gas using the HPCE process allows for an increase in LNG production rate within the SMR liquefaction trains for a given horsepower within the SMR liquefaction trains. **Figures 3 and 4** demonstrate how the disclosed aspects provide such an LNG production increase. **Figure 3** is an illustration of an arrangement of liquefaction modules or trains, such as SMR liquefaction trains, on an LNG production facility such as an FLNG unit **300** according to known principles. A natural gas stream **302** that is pretreated to remove sour gases and water to make the natural gas suitable for cryogenic treatment may be distributed between five identical or nearly identical SMR liquefaction trains **304, 306, 308, 310, 312** arranged in parallel. As an example, each SMR liquefaction train may receive approximately 50 megawatts (MW) of compression power from either a gas turbine or an electric motor (not shown) to drive the compressors of the respective SMR liquefaction train. Each SMR liquefaction module comprises an integrated scrub column to remove heavy hydrocarbons from

the natural gas stream and to recover a sufficient amount of natural gas liquids to provide refrigerant make-up. Each SMR liquefaction module may produce approximately 1.5 million tons per year (MTA) of LNG for a total stream production of approximately 7.5 MTA for the entire FLNG unit **300**.

5 [0049] In contrast, **Figure 4** schematically depicts an LNG liquefaction facility such as an FLNG unit **400** according to disclosed aspects. FLNG unit **400** includes four SMR liquefaction trains **406, 408, 410, 412** arranged in parallel. Unlike the SMR liquefaction trains shown in Figure 3, none of the SMR liquefaction trains **406, 408, 410, 412** include a scrub column. Instead, a natural gas stream **402**, which is pretreated to remove sour gases and water to make
10 the gas suitable for cryogenic treatment, may be directed to a HPCE module **404** to produce a chilled pretreated gas stream **405**. As previously explained, the HPCE module is integrated with a heavy hydrocarbon removal process therein (including a scrub column or similar separator) to remove any hydrocarbons that may form solids during the liquefaction of the natural gas stream **402**. The HPCE module **404** may receive approximately 55 MW of
15 compression power, for example, from either a gas turbine or an electric motor (not shown) to drive one or more compressors within the HPCE module **404**. The chilled pretreated gas stream **405** may be distributed between the SMR liquefaction modules **406, 408, 410, 412**. Each SMR liquefaction module may receive approximately 50 MW of compression power from either a gas turbine or an electric motor (not shown) to drive the compressors of the respective SMR
20 liquefaction modules. Each SMR liquefaction module may produce approximately 1.9 MTA of LNG for a total production of approximately 7.6 MTA of LNG for the FLNG unit **400**. If the FLNG unit **400** uses the disclosed HPCE process module integrated with a single scrub column and cold box (referred to collectively as the HPCE process module **404**), only a single scrub column is required to remove heavy hydrocarbons from the natural gas stream **402**. The
25 replacement of one SMR liquefaction train with the disclosed HPCE module **404** is advantageous since the HPCE module is expected to be smaller, of less weight, and having significantly lower cost than the replaced SMR liquefaction train. Like the replaced SMR liquefaction train, the HPCE module **404** may have an equivalent size gas turbine to provide compression power, and it will also have an equivalent amount of air or water coolers. Unlike
30 the replaced SMR liquefaction train, however, the HPCE module **404** does not have an expensive main cryogenic heat exchanger. The vessels and pipes associated with the refrigerant flow within an SMR module are eliminated in the replaced HPCE liquefaction train. Furthermore, the amount of expensive cryogenic pipes in the HPCE module **404** is significantly

reduced.

[0050] The disclosed HPCE module comprises a single scrub column used to remove the heavy hydrocarbons from the natural gas that is then fed to all the liquefaction trains. This design increases the required power of the HPCE module by 10 to 15% compared to a design
5 where heavy hydrocarbon removal is not included. However, integrating the heavy hydrocarbon removal within the HPCE module instead of within each SMR liquefaction train reduces the weight of each SMR liquefaction train and may result in a total reduction in equipment count and overall topside weight of an FLNG system. Another advantage is that the liquefaction pressure can be greater than the cricondenbar of the feed gas, which results in
10 increased liquefaction efficiency. Furthermore, the proposed design is more flexible to feed gas changes than the integrated scrub column design.

[0051] Another advantage of the disclosed HPCE module is that the required storage of refrigerant is reduced since the number of SMR liquefaction trains has been reduced by one. Also, since a large fraction of the warm temperature cooling of the gas occurs in the HPCE
15 module, the heavier hydrocarbon components of the mixed refrigerant can be reduced. For example, the propane component of the mixed refrigerant may be eliminated without any significant reduction in efficiency of the SMR liquefaction process.

[0052] Another advantage is that for a SMR liquefaction process which receives chilled pretreated gas from the disclosed HPCE module, the volumetric flow rate of the vaporized
20 refrigerant of the SMR liquefaction process can be more than 25% less than that of a conventional SMR liquefaction process receiving warm pretreated gas. The lower volumetric flow of refrigerant may reduce the size of the main cryogenic heat exchanger and the size of the low pressure mixed refrigerant compressor. The lower volumetric flow rate of the refrigerant is due to its higher vaporizing pressure compared to that of a conventional SMR
25 liquefaction process.

[0053] Known propane-precooled mixed refrigeration processes and dual mixed refrigeration (DMR) processes may be viewed as versions of an SMR liquefaction process combined with a pre-cooling refrigeration circuit, but there are significant differences between such processes and aspects of the present disclosure. For example, the known processes use a
30 cascading propane refrigeration circuit or a warm-end mixed refrigerant to pre-cool the gas. Both these known processes have the advantage of providing 5% to 15% higher efficiency than the SMR liquefaction process. Furthermore, the capacity of a single liquefaction train using

these known processes can be significantly greater than that of a single SMR liquefaction train. The pre-cooling refrigeration circuit of these technologies, however, comes at the cost of added complexity to the liquefaction process since additional refrigerants and a substantial amount of extra equipment is introduced. For example, the DMR liquefaction process's disadvantage of higher complexity and weight may outweigh its advantages of higher efficiency and capacity when deciding between a DMR liquefaction process and an SMR liquefaction process for an FLNG application. The known processes have considered the addition of a pre-cooling process upstream of the SMR liquefaction process as being driven principally by the need for higher thermal efficiencies and higher LNG production capacity for a single liquefaction train. The disclosed HPCE process combined with the SMR liquefaction process has not been realized previously because it does not provide the higher thermal efficiencies that the refrigerant-based pre-cooling process provides. As described above, the thermal efficiency of the HPCE process with the SMR liquefaction is about the same as a standalone SMR liquefaction process. The disclosed aspects are believed to be novel based at least in part on its description of a pre-cooling process that aims to reduce the weight and complexity of the liquefaction process rather than increase thermal efficiency, which in the past has been the biggest driver for the addition of a pre-cooling process for onshore LNG applications. As an additional point, the integrated scrub column design is traditionally seen as the lowest cost option for heavy hydrocarbon removal of natural gas to liquefaction. However, the integration of heavy hydrocarbon removal with a HPCE process, as disclosed herein, provides a previously unrealized advantage of potentially reducing total equipment count and weight when multiple liquefaction trains is the preferred design methodology. For the newer applications of FLNG and remote onshore application, footprint, weight, and complexity of the liquefaction process may be a bigger driver of project cost. Therefore the disclosed aspects are of particular value.

25 **[0054]** In an aspect, an expander-based liquefaction process may be enhanced by the addition of an HPCE process upstream of the expander-based process. More specifically, in this aspect, a pretreated natural gas stream may be compressed to pressure greater than 1,500 psia (10,340 kPA), or more preferably greater than 3,000 psia (20,680 kPA). The hot compressed gas may then be cooled by exchanging heat with the environment to form a
30 compressed pretreated gas. The compressed pretreated gas may be near-isentropically expanded to a pressure less than 3,000 psia (20,680 kPA), or more preferably to a pressure less than 2,000 psia (13,790 kPA) to form a first chilled pretreated gas, where the pressure of the first chilled pretreated gas is less than the pressure of the compressed pretreated gas. The first

chilled pretreated gas stream is separated into refrigerant stream and a non-refrigerant stream. The refrigerant stream is warmed by exchanging heat with a column overhead stream in order to help partially condense the column overhead stream and produce a warmed refrigerant stream. The warmed refrigerant stream is mixed with the non-refrigerant stream to produce a
5 second chilled pretreated gas. The second chilled pretreated gas is directed to an expander-based process where the gas is further cooled to form LNG. In a preferred aspect, the second chilled pretreated gas may be directed to a feed gas expander-based process.

[0055] **Figure 5** shows a typical temperature cooling curve **500** for an expander-based liquefaction process. The higher temperature curve **502** is the temperature curve for the natural
10 gas stream. The lower temperature curve **504** is the composite temperature curve of a cold cooling stream and a warm cooling stream. The natural gas is liquefied at pressure above its cricondenbar which allows for the close matching of the natural gas cooling curve (shown at **502**) with the composite temperature curve of the cold and warm cooling streams (shown at **504**) to maximize thermal efficiency. As illustrated, the cooling curve is marked by three
15 temperature pinch-points **506**, **508**, and **510**. Each pinch point is a location within the heat exchanger where the combined heat capacity of the cooling streams is less than that of the natural gas stream. This imbalance in heat capacity between the streams results in a reduction of the temperature difference between the cooling stream to the minimally acceptable temperature difference which provides effective heat transfer rate. The lowest temperature
20 pinch-point **506** occurs where the colder of the two cooling streams, typically the cold cooling stream, enters the heat exchanger. The intermediate temperature pinch-point **508** occurs where the second cooling stream, typically the warm cooling stream, enters the heat exchanger. The warm temperature pinch-point **510** occurs where the cold and warm cooling streams exit the heat exchanger. The warm temperature pinch-point **510** causes a need for a high mass flow
25 rate for the warmer cooling stream, which subsequently increases the power demand of the expander-based process.

[0056] One proposed method to eliminate the warm temperature pinch-point **510** is to pre-cool the feed gas with an external refrigeration system such as a propane cooling system or a carbon dioxide cooling system. For example, United States Patent No. 7,386,996 eliminates
30 the warm temperature pinch-point by using a pre-cooling refrigeration process comprising a carbon dioxide refrigeration circuit in a cascade arrangement. This external pre-cooling refrigeration system has the disadvantage of significantly increasing the complexity of the liquefaction process since an additional refrigerant system with all its associated equipment is

introduced. Aspects disclosed herein reduce the impact of the warm temperature pinch-point
510 by pre-cooling the feed gas stream by compressing the feed gas to a pressure greater than
1,500 psia (10,340 kPA), cooling the compressed feed gas stream, and expanding the
compressed gas stream to a pressure less than 2,000 psia (20,690 kPA), where the expanded
5 pressure of the feed gas stream is less than the compressed pressure of the feed gas stream.
This process of cooling the feed gas stream results in a significant reduction in the in the
required mass flow rate of the expander-based process cooling streams. It also improves the
thermodynamic efficiency of the expander-based process without significantly increasing the
equipment count and without the addition of an external refrigerant. This process may also be
10 integrated with heavy hydrocarbon removal in order to remove the heavy hydrocarbon
upstream of the liquefaction process. Since the gas is now free of heavy hydrocarbons that
would form solids, the pretreated gas can be liquefied at a pressure above its cricondenbar in
order to improve liquefaction efficiency.

[0057] In a preferred aspect, the expander-based process may be a feed gas expander-based
15 process. This feed gas expander process comprises a first closed expander-based refrigeration
loop and a second closed expander-based refrigeration loop. The first expander-based
refrigeration loop may be principally charged with methane from a feed gas stream. The first
expander-based refrigeration loop liquefies the feed gas stream. The second expander-based
refrigeration loop may be charged with nitrogen as the refrigerant. The second expander-based
20 refrigeration loop sub-cools the LNG streams. Specifically, a produced natural gas stream may
be treated to remove impurities, if present, such as water, and sour gases, to make the natural
gas suitable for cryogenic treatment. The treated natural gas stream may be directed to a scrub
column where the treated natural gas stream is separated into a column overhead stream and a
column bottom stream. The column overhead stream may be partially condensed within a first
25 heat exchanger by indirectly exchanging heat with a cold pretreated gas stream and a refrigerant
stream to thereby form a two phase stream. The two phase stream may be directed to a
separator where the two phase stream is separated into the cold pretreated gas stream and a
liquid stream. The cold pretreated gas stream may be warmed within the first heat exchanger
by exchanging heat with the column overhead stream to form a pretreated natural gas stream.
30 The liquid stream may be pressurized within a pump and then directed to the scrub column to
provide reflux to the scrub column. The pretreated natural gas stream may be directed to an
HPCE process as disclosed herein, where it is compressed to a pressure greater than 1,500 psia
(10,340 kPA), or more preferably greater than 3,000 psia (20,680 kPA). The hot compressed

gas stream may then be cooled by exchanging heat with the environment to form a compressed treated natural gas stream. The compressed treated natural gas stream may be near-isentropically expanded to a pressure less than 3,000 psia (20,680 kPA), or more preferably to a pressure less than 2,000 psia (12,790 kPA) to form a first chilled treated natural gas stream, where the pressure of the first chilled treated natural gas stream is less than the pressure of the compressed treated natural gas stream. The first chilled natural gas stream may be separated into the refrigerant stream and a non-refrigerant stream. The refrigerant stream may be partially warmed within the first heat exchanger by exchanging heat with the column overhead stream to form a warmed refrigerant stream. The warmed refrigerant stream may mix with the non-refrigerant stream to form a second chilled natural gas stream. The second chilled treated natural gas may be directed to the feed gas expander process where the first expander-based refrigeration loop acts to liquefy the second chilled treated natural gas to form a pressurized LNG stream. The second expander refrigeration loop then acts to subcool the pressurized LNG stream. The subcooled pressurized LNG stream may then be expanded to a lower pressure in order to form an LNG stream.

[0058] The combination of the HPCE process with pretreatment of the natural gas and liquefaction of the pretreated gas within an expander-based process has several advantages over a conventional expander-based process. Including the HPCE process therewith may increase the efficiency of the expander-based process by 5 to 25% depending of the type of expander-based process employed. The feed gas expander process described herein may have a liquefaction efficiency similar to that of an SMR process while still providing the advantages of no external refrigerant use, ease of operation, and reduced equipment count. Furthermore, the refrigerant flow rates and the size of the recycle compressors are expected to be significantly lower for the expander-base process combined with the HPCE process. For these reasons, the production capacity of a single liquefaction train according to disclosed aspects may be greater than 30 to 50% above the production capacity of a similarly sized conventional expander-based liquefaction process. The combination of HPCE process with heavy hydrocarbon removal upstream of an expander-based liquefaction process has the additional benefit of providing the option to liquefy the gas at pressures above its cricondenbar to improve liquefaction efficiency. Expander-based liquefaction processes are particularly sensitive to liquefaction pressures. Therefore, the HPCE process described herein is well suited for removing heavy hydrocarbons while also increasing the liquefaction efficiency and production capacity of expander-based liquefaction processes.

[0059] Figure 6 is an illustration of an aspect of an HPCE module **600** with an integrated scrub column according to another aspect of the disclosure. A natural gas stream **601**, which has been pretreated to remove sour gases and water to make the gas suitable for cryogenic treatment, is fed into a separation device, such as a scrub column **602**, where the natural gas stream **601** is separated into a column overhead stream **603** and a column bottom stream **604**.
5 The column overhead stream **603** may flow through a first heat exchanger **605** where the column overhead stream **603** is partially condensed to form a two-phase stream **606**. The two-phase stream **606** may be directed to another separation device, such as a separator **607**, to form a cold pretreated gas stream **608** and a liquid stream **609**. The cold pretreated gas stream **608**
10 may flow through the first heat exchanger **605** where the cold pretreated gas stream **608** is warmed by indirect heat exchange with the column overhead stream **603** to form a pretreated natural gas stream **610** therefrom. The liquid stream may be pressurized within a pump **611** and then directed to the scrub column **602** as a column reflux stream. The pretreated natural gas stream **610** is directed to a first compressor **612** and compressed therein to form a first intermediate pressure gas stream **613**. The first intermediate pressure gas stream **613** may flow through a second heat exchanger **614** where the first intermediate pressure gas stream **613** is cooled by indirect heat exchange with the environment to form a cooled first intermediate pressure gas stream **615**. The second heat exchanger **614** may be an air cooled heat exchanger or a water cooled heat exchanger. The cooled first intermediate pressure gas stream **615** may then be compressed within a second compressor **616** to form a second intermediate pressure gas stream **617**. The second intermediate pressure gas stream **617** may flow through a third heat exchanger **618** where the second intermediate pressure gas stream **617** is cooled by indirect heat exchange with the environment to form a cooled second intermediate pressure gas stream **619**. The third heat exchanger **618** may be an air cooled heat exchanger or a water cooled heat exchanger. The cooled second intermediate pressure gas stream **619** may then be compressed within a third compressor **620** to form a high pressure gas stream **621**. The pressure of the high pressure gas stream **621** may be greater than 1,500 psia (10,340 kPa), or more preferably greater than 3,000 psia (20,680 kPa). The high pressure gas stream **621** may flow through a fourth heat exchanger **622** where the high pressure gas stream **621** is cooled by indirectly exchanging heat with the environment to form a cooled high pressure gas stream **623**. The fourth heat exchanger **622** may be an air cooled heat exchanger or a water cooled heat exchanger. The cooled high pressure gas stream **623** may then be expanded within an expander **624** to form a first chilled pretreated gas stream **625**. The pressure of the first chilled pretreated gas stream **625** may be less than 3,000 psia (20,680 kPa), or more preferably less than 2,000

psia (13,790 kPa), and the pressure of the first chilled pretreated gas stream **625** may be less than the pressure of the cooled high pressure gas stream **623**. In an aspect, the third compressor **620** may be driven solely by the shaft power produced by the expander **624**, as illustrated by line **624a**. The first chilled pretreated gas stream **625** may be separated into a refrigerant stream **626** and a non-refrigerant stream **627**. The refrigerant stream **626** may flow through the first heat exchanger **605** where the refrigerant stream **626** is partially warmed by indirectly exchanging heat with the column overhead stream **603** to form a warmed refrigerant stream **628** therefrom. The warmed refrigerant stream **628** may mix with the non-refrigerant stream **627** to form a second chilled pretreated gas stream **629**, which may then be liquefied by an SMR liquefaction process as previously explained. As with pretreatment apparatus **200**, the refrigerant stream **626** may be used to cool any process stream associated or not associated with the HPCE module **600**.

[0060] **Figure 7** is an illustration of an HPCE module **700** with an integrated scrub column and combined with a feed gas expander-based LNG liquefaction process according to disclosed aspects. A natural gas stream **701**, which has been pretreated to remove sour gases and water to make the gas suitable for cryogenic treatment, is fed into a separation device, such as a scrub column **702**, where the treated natural gas stream **701** is separated into a column overhead stream **703** and a column bottom stream **704**. The column overhead stream **703** may flow through a first heat exchanger **705** where the column overhead stream **703** is partially condensed to form a two-phase stream **706**. The two-phase stream **706** may be directed to another separation device, such as a separator **707**, to form a cold pretreated gas stream **708** and a liquid stream **709**. The cold pretreated gas stream **708** may flow through the first heat exchanger **705** where the cold pretreated gas stream **708** is warmed by indirect heat exchange with the column overhead stream **703** to form a pretreated natural gas stream **710** therefrom. The liquid stream **709** may be pressurized within a pump **711** and then directed to the scrub column **702** as a column reflux. The pretreated natural gas stream **710** is directed to a first compressor **713** and compressed therein to form an intermediate pressure gas stream **714**. The intermediate pressure gas stream **714** may flow through a second heat exchanger **715** where the intermediate pressure gas stream **714** is cooled by indirect heat exchange with the environment to form a cooled intermediate pressure gas stream **716**. The second heat exchanger **715** may be an air cooled heat exchanger or a water cooled heat exchanger. The cooled intermediate pressure gas stream **716** may then be compressed within a second compressor **717** to form a high pressure gas stream **718**. The pressure of the high pressure gas

stream **718** may be greater than 1,500 psia (10,340 kPa), or more preferably greater than 3,000 psia (20,680 kPa). The high pressure gas stream **718** may flow through a third heat exchanger **719** where the high pressure gas stream **718** is cooled by indirect heat exchange with the environment to form a cooled high pressure gas stream **720**. The third heat exchanger **719** may be an air cooled heat exchanger or a water cooled heat exchanger. The cooled high pressure gas stream **720** may then be expanded within an expander **721** to form a first chilled pretreated gas stream **722**. The pressure of the first chilled pretreated gas stream **722** is less than 3,000 psia (20,680 kPa), or more preferably less than 2,000 psia (13,790 kPa), and where the pressure of the first chilled pretreated gas stream **722** is less than the pressure of the cooled high pressure gas stream **720**. In an aspect, the second compressor **717** may be driven solely by the shaft power produced by the expander **721**, as represented by the dashed line **723**. The first chilled pretreated gas stream **722** may be separated into a refrigerant stream **724** and a non-refrigerant stream **725**. The refrigerant stream **724** may flow through the first heat exchanger **705** where the refrigerant stream **724** is partially warmed by indirect heat exchange with the column overhead stream **703** to form a warmed refrigerant stream **726** therefrom. The warmed refrigerant stream **726** may mix with the non-refrigerant stream **725** to form a second chilled pretreated gas stream **727**. As with pretreatment apparatus **200** and HPCE module **600**, the refrigerant stream **724** may be used to cool any process stream associated or not associated with the HPCE module **700**.

[0061] As illustrated in **Figure 7**, the second chilled pretreated gas stream **727** is directed to a feed gas expander-based LNG liquefaction process **730**. The feed gas expander-based process **730** includes a primary cooling loop **732**, which is a closed expander-based refrigeration loop that may be charged with components from the feed gas stream. The liquefaction system also includes a subcooling loop **734**, which is also a closed expander-based refrigeration loop preferably charged with nitrogen as the sub-cooling refrigerant. Within the primary cooling loop **732**, an expanded, cooled refrigerant stream **736** is directed to a first heat exchanger zone **738** where it exchanges heat with the second chilled pretreated gas stream **727** to form a first warm refrigerant stream **740**. The first warm refrigerant **740** is directed to a second heat exchanger zone **742** where it exchanges heat with a compressed, cooled refrigerant stream **744** to additionally cool the compressed, cooled refrigerant stream **744** and form a second warm refrigerant stream **746** and a compressed, additionally cooled refrigerant stream **748**. The second heat exchanger zone **742** may comprise one or more heat exchangers where the one or more heat exchangers may be of a printed circuit heat exchanger type, a shell and

tube heat exchanger type, or a combination thereof. The heat exchanger types within the second heat exchanger zone **742** may have a design pressure of greater than 1,500 psia, or more preferably, a design pressure of greater than 2,000 psia, or more preferably, a design pressure of greater than 3,000 psia.

5 **[0062]** The second warm refrigerant stream **746** is compressed in one or more compression units **750**, **752** to a pressure greater than 1,500 psia, or more preferably, to a pressure of approximately 3,000 psia, to thereby form a compressed refrigerant stream **754**. The compressed refrigerant stream **754** is then cooled against an ambient cooling medium (air or water) in a cooler **756** to produce the compressed, cooled refrigerant stream **744**. The
10 compressed, additionally cooled refrigerant stream **748** is near isentropically expanded in an expander **758** to produce the expanded, cooled refrigerant stream **736**. The expander **758** may be a work expansion device, such as a gas expander, which produces work that may be extracted and used for compression.

[0063] The first heat exchanger zone **738** may include a plurality of heat exchanger devices, and in the aspects shown in **Figure 7**, the first heat exchanger zone includes a main heat
15 exchanger **760** and a sub-cooling heat exchanger **762**. These heat exchangers may be of a brazed aluminum heat exchanger type, a plate fin heat exchanger type, a spiral wound heat exchanger type, or a combination thereof.

[0064] Within the sub-cooling loop **734**, an expanded sub-cooling refrigerant stream **764**
20 (preferably comprising nitrogen) is discharged from an expander **766** and drawn through the sub-cooling heat exchanger **762** and the main heat exchanger **760**. The expanded sub-cooling refrigerant stream **764** is then sent to a compression unit **768** where it is re-compressed to a higher pressure and warmed. After exiting compression unit **768**, the resulting recompressed sub-cooling refrigerant stream **770** is cooled in a cooler **772**. After cooling, the recompressed
25 sub-cooling refrigerant stream **770** is passed through the main heat exchanger **760** where it is further cooled by indirect heat exchange with the expanded, cooled refrigerant stream **736** and the expanded sub-cooling refrigerant stream **764**. After exiting the first heat exchanger area **738**, the re-compressed and cooled sub-cooling refrigerant stream is expanded through the expander **766** to provide the expanded sub-cooling refrigerant stream **764** that is re-cycled
30 through the first heat exchanger zone as described herein. In this manner, the second chilled pretreated gas stream **727** is further cooled, liquefied and sub-cooled in the first heat exchanger zone **738** to produce a sub-cooled gas stream **774**. The sub-cooled gas stream **774** may be expanded to a lower pressure to produce the LNG stream (not shown).

[0065] **Figure 8** illustrates a method **800** of producing LNG according to disclosed aspects. At block **802** heavy hydrocarbons are removed from the natural gas stream to thereby generate a separated natural gas stream. At block **804** the separated natural gas stream is partially condensed in a first heat exchanger to thereby generate a partially condensed natural gas stream. At block **806** liquids are separated from the partially condensed natural gas stream to thereby generate a pretreated natural gas stream. At block **808** the pretreated natural gas stream is compressed in at least two serially arranged compressors to a pressure of at least 1,500 psia to form a compressed natural gas stream. At block **810** the compressed natural gas stream is cooled to form a cooled compressed natural gas stream. At block **812** the cooled natural gas stream is expanded to a pressure that is less than 2,000 psia and no greater than the pressure to which the at least two serially arranged compressors compress the pretreated natural gas stream, to thereby form a chilled natural gas stream. At block **814** the chilled natural gas stream is separated into a refrigerant stream and a non-refrigerant stream. At block **816** the refrigerant stream is warmed through heat exchange with one or more process streams comprising the natural gas stream, the separated natural gas stream, the partially condensed natural gas stream, and the pretreated natural gas stream, thereby generating a warmed refrigerant stream. At block **818** the warmed refrigerant stream and the non-refrigerant stream are liquefied.

[0066] **Figure 9** illustrates a method **900** of producing LNG according to disclosed aspects. At block **902** the natural gas stream is pretreated to generate a pretreated natural gas stream. At block **904** the pretreated natural gas stream is compressed in at least two serially arranged compressors to a pressure of at least 1,500 psia. At block **906** the compressed natural gas stream is cooled. At block **908** the cooled compressed natural gas stream is expanded in at least one work producing natural gas expander to a pressure that is less than 2,000 psia and no greater than the pressure to which the at least two serially arranged compressors compress the pretreated natural gas stream, to thereby form a chilled natural gas stream. At block **910** the chilled natural gas stream is separated into a refrigerant stream and a non-refrigerant stream. At block **912** the refrigerant stream is warmed in a heat exchanger through heat exchange with one or more process streams associated with pretreating the natural gas stream, thereby generating a warmed refrigerant stream. At block **914** the warmed refrigerant stream and the non-refrigerant stream are liquefied.

While the foregoing is directed to aspects of the present disclosure, other and further aspects of the disclosure may be devised without departing from the basic scope thereof, and the scope thereof is determined by the claims that follow.

CLAIMS

What is claimed is:

1. A method of producing liquefied natural gas (LNG) from a natural gas stream, the method comprising:
 - 5 removing heavy hydrocarbons from the natural gas stream to thereby generate a separated natural gas stream;
 - partially condensing the separated natural gas stream in a first heat exchanger to thereby generate a partially condensed natural gas stream;
 - 10 separating liquids from the partially condensed natural gas stream to thereby generate a pretreated natural gas stream;
 - compressing the pretreated natural gas stream in at least two serially arranged compressors to a pressure of at least 1,500 psia to form a compressed natural gas stream;
 - cooling the compressed natural gas stream to form a cooled compressed natural gas stream;
 - 15 expanding, in at least one work producing natural gas expander, the cooled compressed natural gas stream to a pressure that is less than 2,000 psia and no greater than the pressure to which the at least two serially arranged compressors compress the pretreated natural gas stream, to thereby form a chilled natural gas stream;
 - 20 separating the chilled natural gas stream into a refrigerant stream and a non-refrigerant stream;
 - warming the refrigerant stream through heat exchange with one or more process streams comprising the natural gas stream, the separated natural gas stream, the partially condensed natural gas stream, and the pretreated natural gas stream, thereby generating a warmed refrigerant stream; and
 - 25 liquefying the warmed refrigerant stream and the non-refrigerant stream.
2. The method of claim 1, wherein the refrigerant stream is warmed through heat exchange with the separated natural gas stream.
- 30 3. The method of claim 1 or claim 2, wherein the heavy hydrocarbons are separated from the natural gas stream in a scrub column, and further comprising:
 - directing the separated liquids to the scrub column as a column reflux stream;
 - wherein the one or more process streams further comprise the column reflux stream.

4. The method of any one of claims 1-3, further comprising:
prior to compressing the pretreated natural gas stream, warming the pretreated natural
gas stream through heat exchange with the separated natural gas stream in the first heat
5 exchanger.
5. The method of any one of claims 1-4, wherein liquefying the chilled pretreated natural
gas stream is performed in one or more single mixed refrigerant (SMR) liquefaction trains.
- 10 6. The method of claim 5, wherein liquefying the chilled pretreated natural gas stream is
performed in at least three parallel SMR liquefaction trains.
7. The method of any one of claims 1-6, wherein liquefying the chilled pretreated natural
gas stream is performed in one or more expander-based liquefaction modules, and wherein the
15 expander-based liquefaction module is a nitrogen gas expander-based liquefaction module or
a feed gas expander-based liquefaction module.
8. The method of any one of claims 1-7, wherein the at least two compressors compress
the natural gas stream to a pressure greater than 3,000 psia, and wherein the work producing
20 natural gas expander expands the cooled compressed natural gas stream to a pressure less than
2,000 psia.
9. The method of any one of claims 1-8, wherein the work producing natural gas expander
is mechanically coupled to at least one compressor.
- 25 10. The method of any one of claims 1-9, wherein cooling the compressed natural gas
stream comprises cooling the compressed natural gas stream in at least one heat exchanger that
exchanges heat with an environment.
- 30 11. The method of any one of claims 1-10, wherein one of the at least two serially arranged
compressors is driven by the natural gas expander.
12. The method of any one of claims 1-11, wherein the at least two serially arranged
compressors comprise three serially arranged compressors, and wherein one of the three

serially arranged compressors is driven by the work producing natural gas expander.

13. The method of any one of claims 1-12, further comprising:
performing the removing, partially condensing, separating, compressing, cooling,
5 expanding, separating, warming, combining, and liquefying steps on a topside of a floating
LNG structure.

14. The method of claim 13, wherein the removing, partially condensing, separating,
compressing, cooling, expanding, separating, warming, and combining steps are performed
10 within a single module on the topside of the floating LNG structure.

15. An apparatus for the liquefaction of natural gas, comprising:
a first separation device configured to remove heavy hydrocarbons from a natural gas
stream to thereby generate a separated natural gas stream;
15 a first heat exchanger that partially condenses the separated natural gas stream, thereby
forming a partially condensed natural gas stream;
a second separation device that separates liquids from the partially condensed natural
gas stream to thereby generate a liquids stream and a pretreated natural gas stream;
at least two serially arranged compressors configured to compress the pretreated natural
20 gas stream to a pressure greater than 1,500 psia, thereby forming a compressed natural gas
stream;
a cooling element configured to cool the compressed natural gas stream, thereby
forming a cooled compressed natural gas stream;
at least one work-producing expander configured to expand the cooled compressed
25 natural gas stream to a pressure which is less than 2,000 psia and is no greater than the pressure
to which the at least two serially arranged compressors compress the pretreated natural gas
stream, to thereby form a chilled natural gas stream;
wherein the chilled natural gas stream is separated into a refrigerant stream and a non-
refrigerant stream, and wherein the refrigerant stream is warmed through heat exchange in the
30 first heat exchanger with one or more of the natural gas stream, the separated natural gas
stream, the partially condensed natural gas stream, the pretreated natural gas stream, and the liquids
stream, thereby generating a warmed refrigerant stream; and
at least one liquefaction train configured to liquefy the warmed refrigerant stream and
the non-refrigerant stream.

16. The apparatus of claim 15, wherein the first separation device is a scrub column, and wherein the liquids stream is directed to the scrub column as a column reflux stream.

5 17. The apparatus of any one of claims 15-16, wherein, prior to compressing the pretreated natural gas stream, the pretreated natural gas stream is directed to the first heat exchanger to be warmed through heat exchange with the separated natural gas stream therein.

10 18. The apparatus of any one of claims 15-17, wherein the at least one liquefaction train comprises at least one single mixed refrigerant (SMR) liquefaction module or at least one expander-based liquefaction module.

15 19. The apparatus of claim 18, wherein the at least one liquefaction train comprises at least one expander-based liquefaction module that is one of a nitrogen gas expander-based liquefaction module and a feed gas expander-based liquefaction module.

20. The apparatus of any one of claims 15-19, wherein the at least two compressors compress the pretreated natural gas stream to a pressure greater than 3,000 psia.

20 21. The apparatus of any one of claims 15-20, wherein the natural gas expander is a work producing expander configured to expand the cooled compressed natural gas stream to a pressure less than 2,000 psia.

25 22. The apparatus of any one of claims 15-21, wherein the natural gas expander is mechanically coupled to at least one compressor.

23. The apparatus of any one of claims 15-22, wherein the cooling element comprises a heat exchanger configured to cool the compressed natural gas stream by exchanging heat with an environment.

30

24. The apparatus of any one of claims 15-23, wherein one of the at least two serially arranged compressors is driven by the natural gas expander.

25. The apparatus of any one of claims 15-24, wherein the at least two serially arranged

compressors comprise three serially arranged compressors, and wherein one of the three serially arranged compressors is driven by the natural gas expander.

26. The apparatus of any one of claims 15-25, wherein the first and second separation devices, the first heat exchanger, at least two serially arranged compressors, the cooling element, the at least one work-producing expander, and the liquefaction train are disposed on a floating LNG structure.

27. The apparatus of claim 26, wherein the at least two serially arranged compressors, the cooling element, the first heat exchanger, the first and second separation devices, and the at least one work-producing expander are disposed within a single module on a topside of the floating LNG structure.

28. A floating LNG structure, comprising:

15 a first separation device configured to remove heavy hydrocarbons from a natural gas stream, to thereby generate a separated natural gas stream;

a first heat exchanger that partially condenses the separated natural gas stream, thereby forming a partially condensed natural gas stream;

a second separation device that separates liquids from the partially condensed natural gas stream to thereby generate a liquids stream and a pretreated natural gas stream;

20 at least two serially arranged compressors configured to compress the pretreated natural gas stream to a pressure greater than 1,500 psia, thereby forming a compressed natural gas stream;

a cooling element configured to cool the compressed natural gas stream, thereby forming a cooled compressed natural gas stream;

25 at least one work-producing expander configured to expand the cooled compressed natural gas stream to a pressure less than 2,000 psia and no greater than the pressure to which the at least two serially arranged compressors compress the natural gas stream, to thereby form a chilled natural gas stream;

30 wherein the chilled natural gas stream is separated into a refrigerant stream and a non-refrigerant stream, and wherein the refrigerant stream is warmed through heat exchange in the first heat exchanger with one or more of the natural gas stream, the separated natural gas stream, the partially condensed natural gas stream, the pretreated natural gas stream, and the liquids stream, thereby generating a warmed refrigerant stream; and

at least one liquefaction train configured to liquefy the warmed refrigerant stream and the non-refrigerant stream.

29. A method of producing liquefied natural gas from a natural gas stream, the method
5 comprising:

pretreating the natural gas stream to generate a pretreated natural gas stream;

compressing the pretreated natural gas stream in at least two serially arranged
compressors to a pressure of at least 1,500 psia to form a compressed natural gas stream;

10 cooling the compressed natural gas stream to form a cooled compressed natural gas
stream;

expanding, in at least one work producing natural gas expander, the cooled compressed
natural gas stream to a pressure that is less than 2,000 psia and no greater than the pressure to
which the at least two serially arranged compressors compress the pretreated natural gas stream,
to thereby form a chilled natural gas stream;

15 separating the chilled natural gas stream into a refrigerant stream and a non-refrigerant
stream;

in a heat exchanger, warming the refrigerant stream through heat exchange with one or
more process streams associated with pretreating the natural gas stream, thereby generating a
warmed refrigerant stream; and

20 liquefying the warmed refrigerant stream and the non-refrigerant stream.

30. The method of claim 29, wherein pretreating the natural gas stream comprises at least
one of :

removing heavy hydrocarbons from the natural gas stream;

25 partially condensing the natural gas stream;

separating liquids from the partially condensed natural gas stream; and

cooling the natural gas stream.

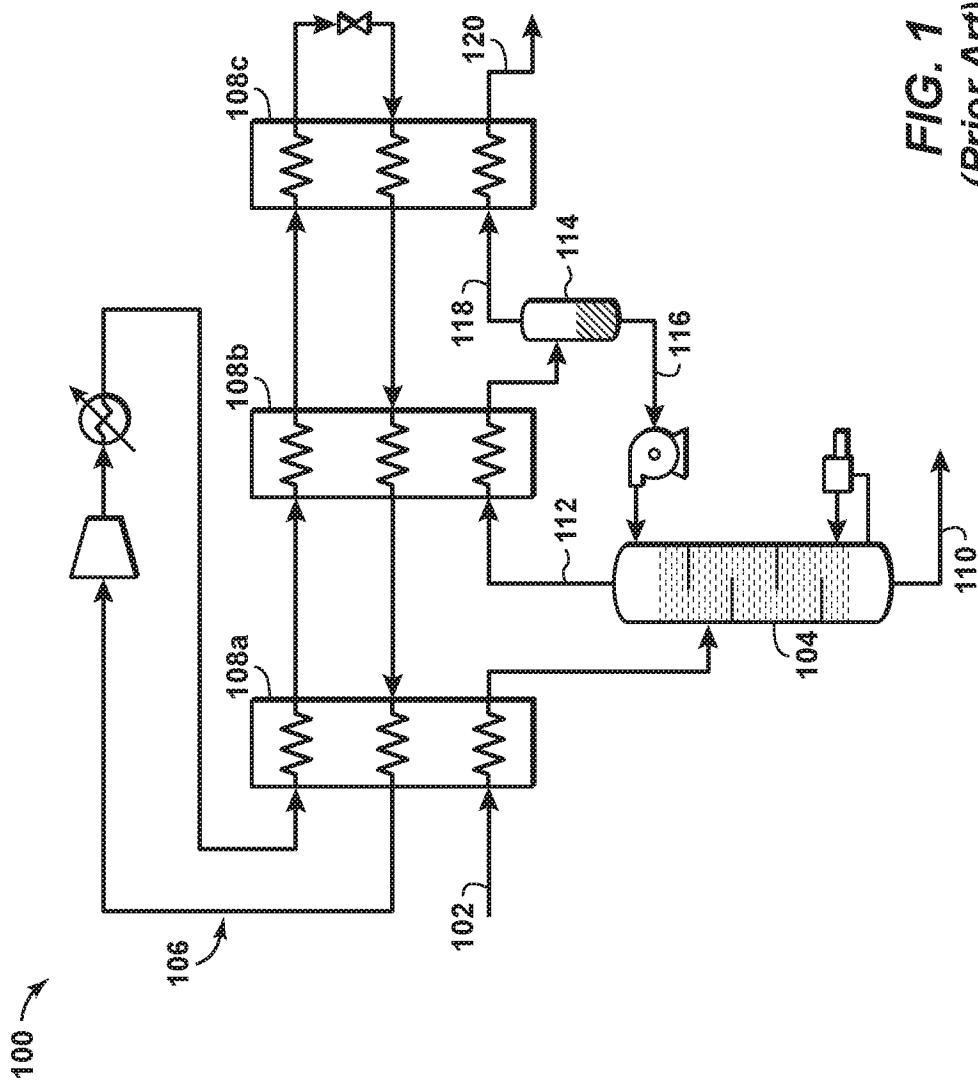

FIG. 1
(Prior Art)

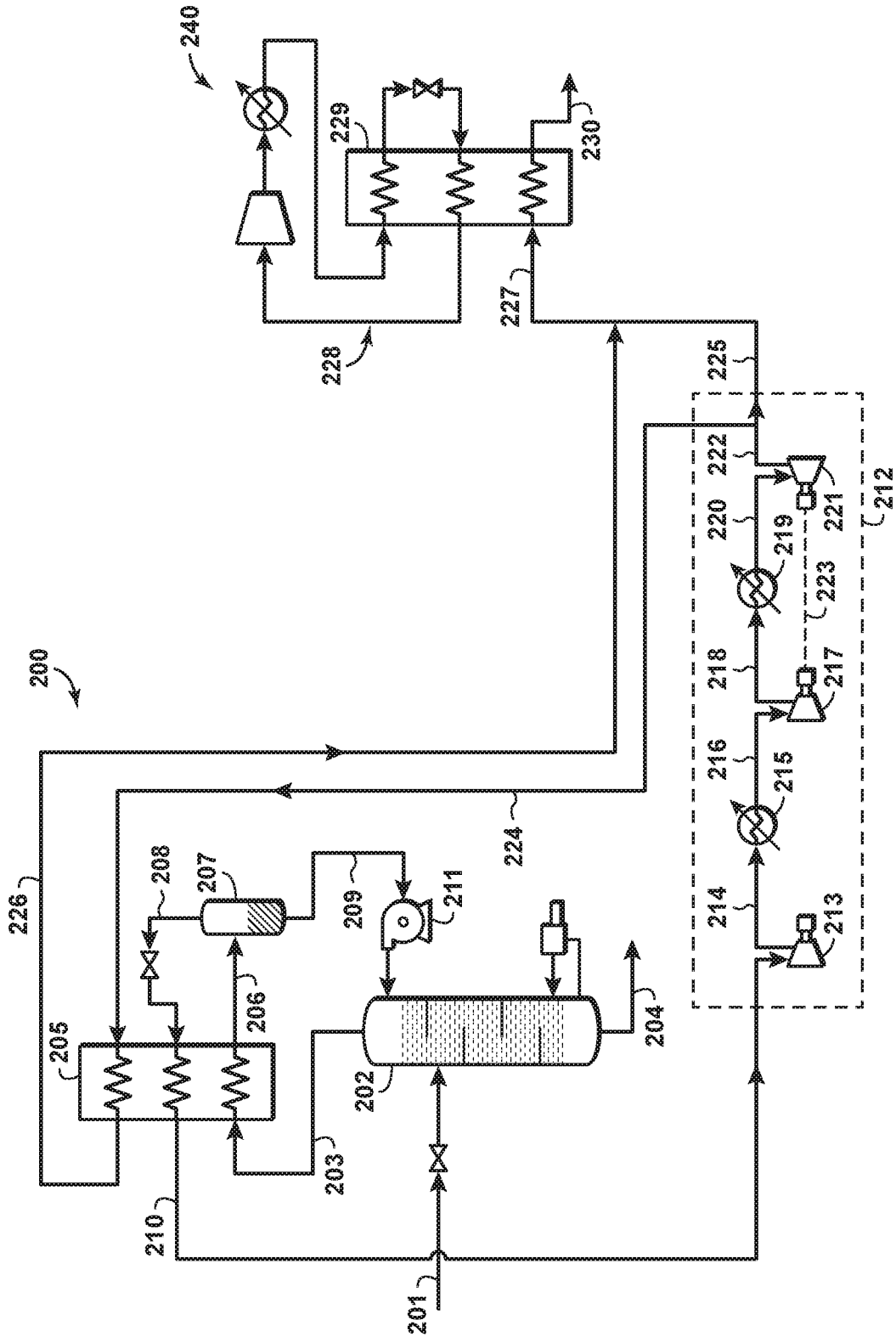

FIG. 2

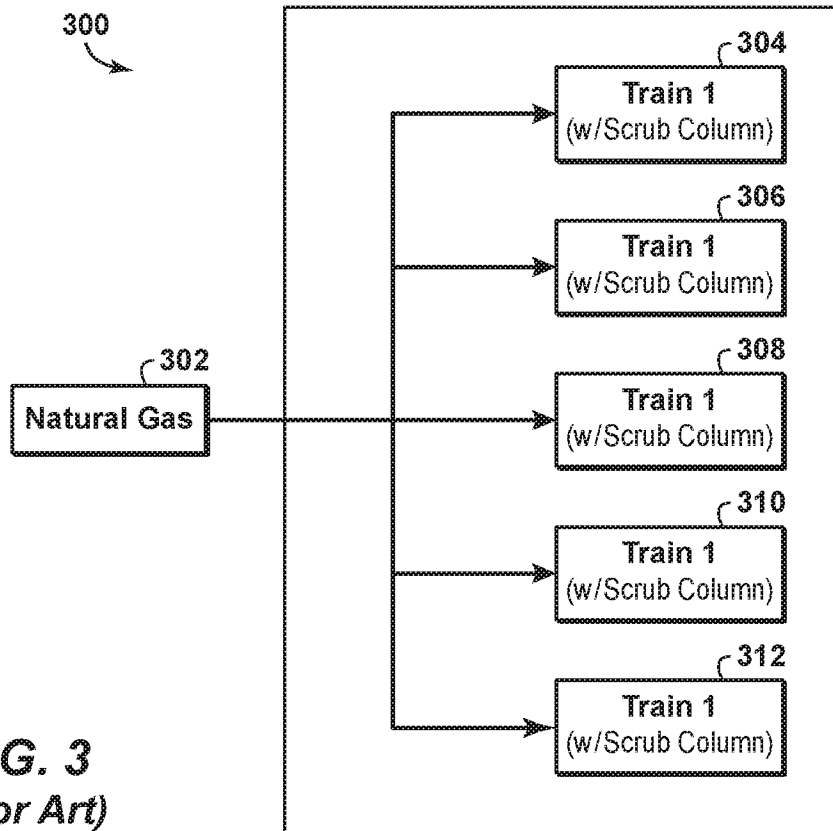

FIG. 3
(Prior Art)

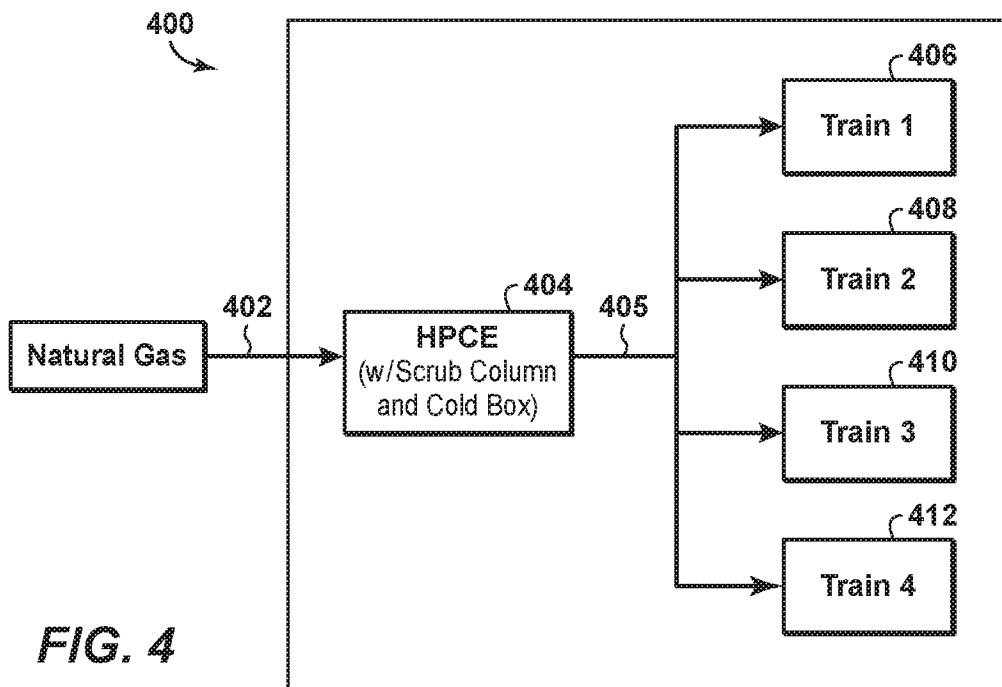

FIG. 4

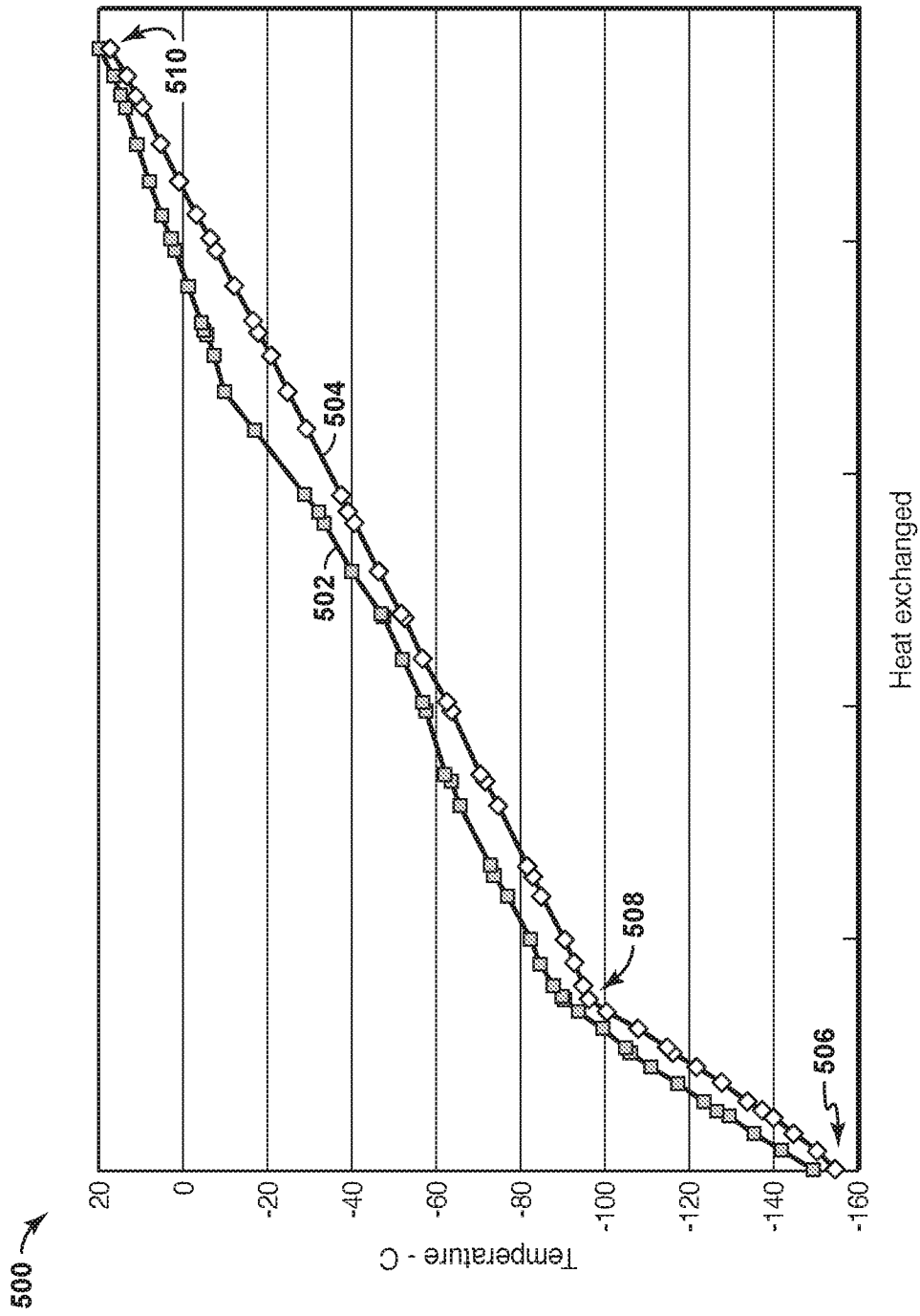

FIG. 5

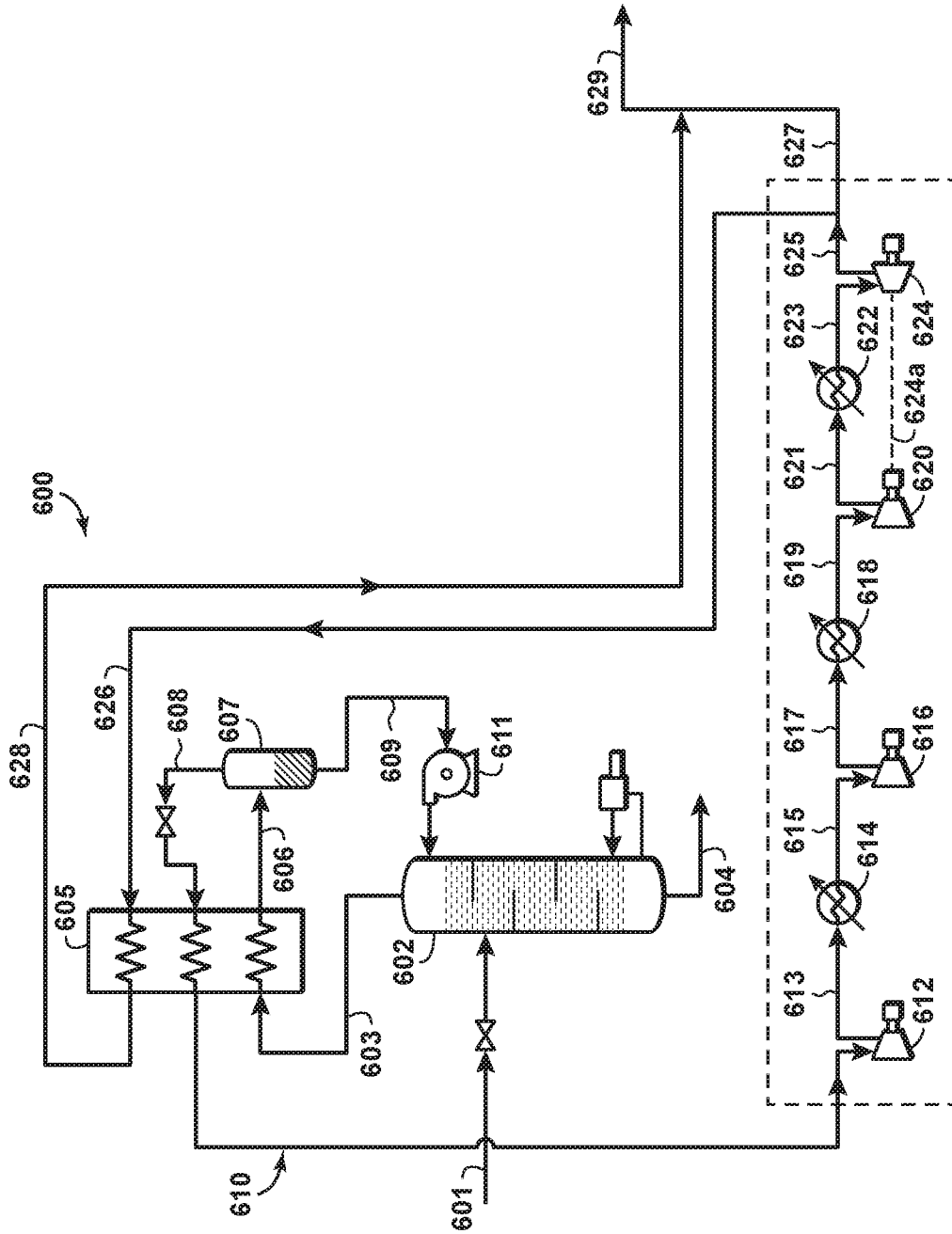

FIG. 6

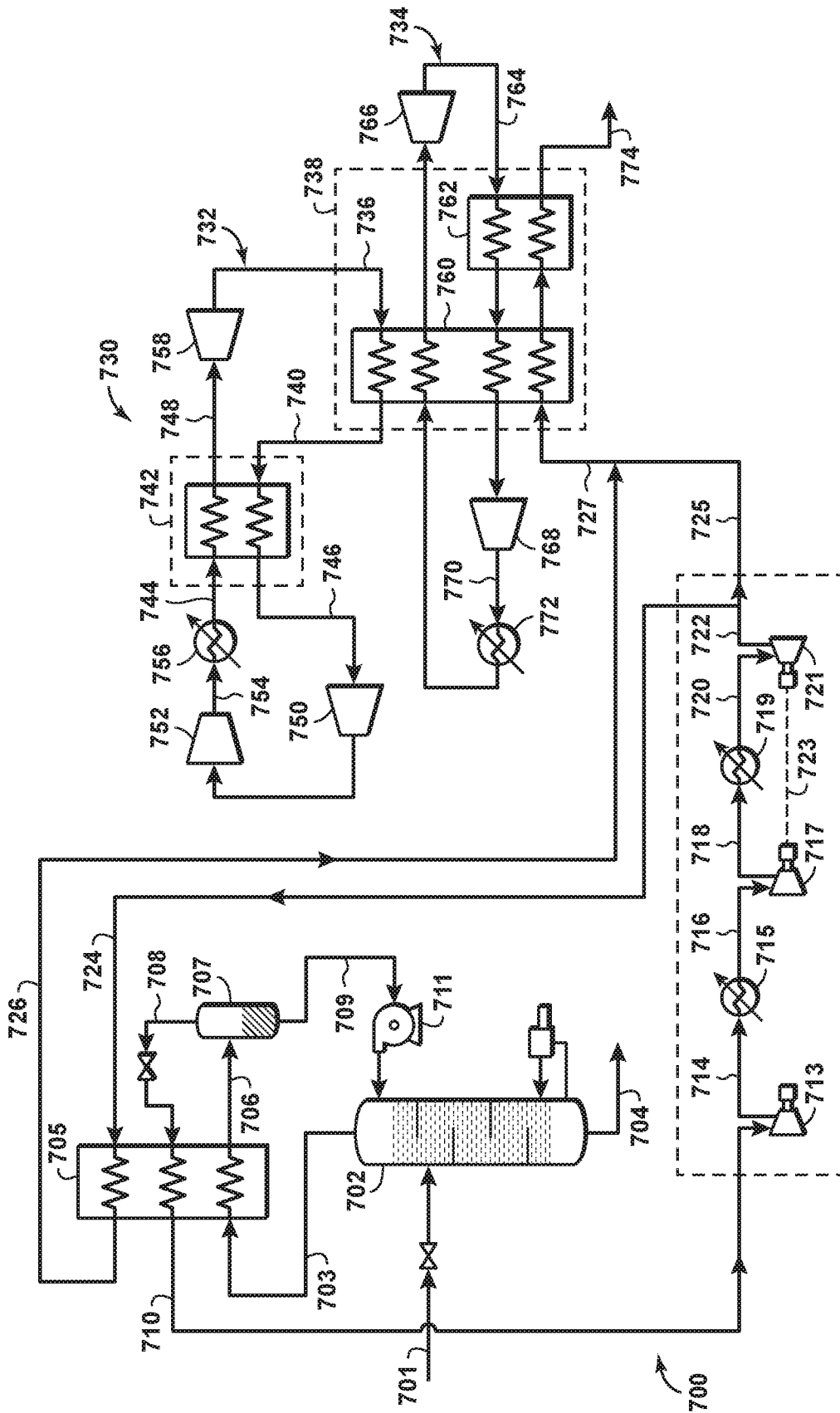

FIG. 7

7/7

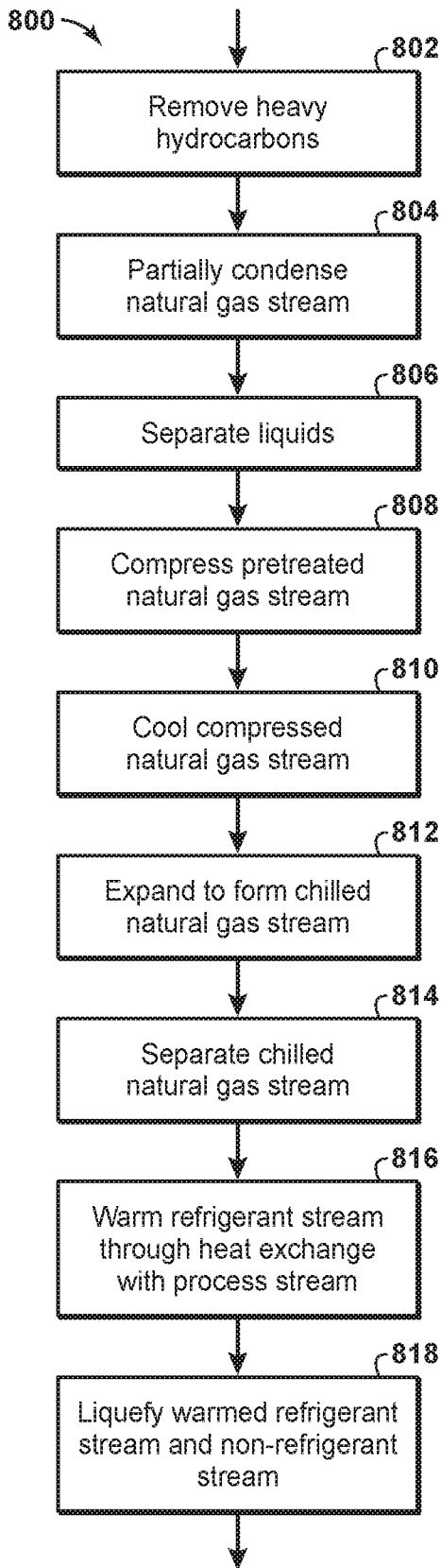

FIG. 8

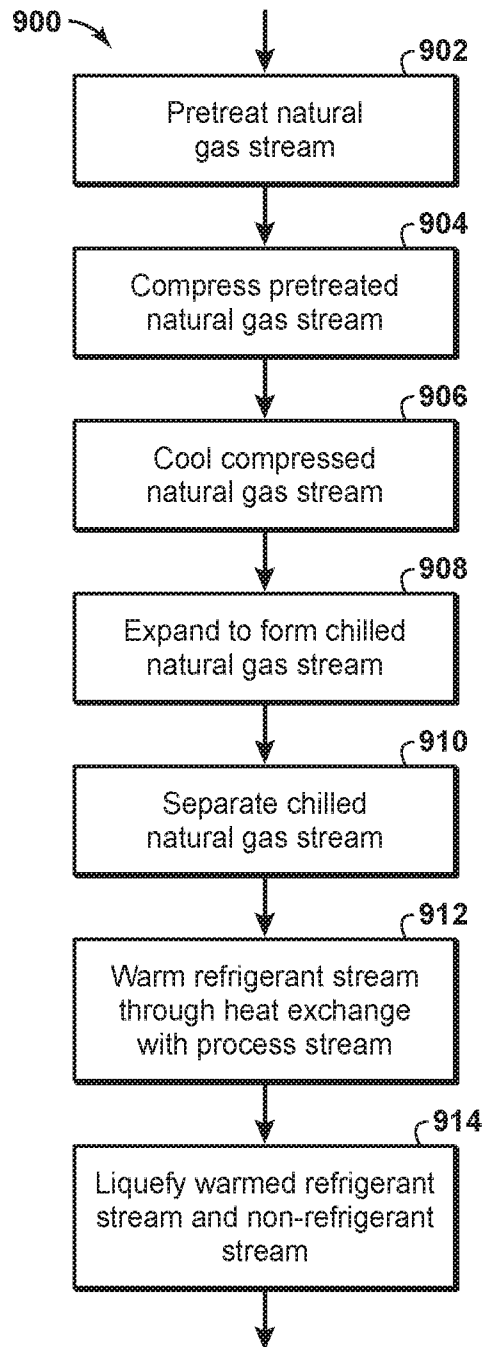

FIG. 9