

(21) Application No: 1701069.5  
(22) Date of Filing: 23.01.2017  
(30) Priority Data:  
(31) 1601500 (32) 27.01.2016 (33) GB

(51) INT CL:  
B26D 1/547 (2006.01) B26B 27/00 (2006.01)

(56) Documents Cited:  
GB 2526308 A GB 2489835 A  
WO 2011/101667 A US 6216969 B

(71) Applicant(s):  
Belron Hungary Kft - Zug branch  
(Incorporated in Switzerland)  
Gotthardstrasse 20, CH-6300 Zug, Switzerland

(72) Inventor(s):  
William Finck

(74) Agent and/or Address for Service:  
Urquhart-Dykes & Lord LLP  
UDL Intellectual Property, 7th Floor, Churchill House,  
17 Churchill Way, Cardiff, CF10 2HH, United Kingdom

(58) Field of Search:  
INT CL B23D, B26B, B26D  
Other: WPI, EPODOC, TXTA

(54) Title of the Invention: **Winder unit for vehicle glazing panel cut out**  
Abstract Title: **Winder unit comprising ratchet device**

(57) A winder unit for winding cutting line in vehicle glazing panel removal, comprising: a rotatable spindle 61 and a ratchet device 80 mounted to the spindle via a one-way bearing or clutch 75. Preferably, the ratchet comprises a collar and rotates in unison with the one-way bearing or clutch. Preferably, a demountable spool 4,5 is mounted to the spindle. Preferably, the unit comprises guide pulleys, suckers and plurality of spindles with ratchet devices. Winder unit operable in: a first mode where the spindle can freewheel in first direction, but is inhibited in second direction; a second mode where the spindle has selectively applied resistance in first direction, but is inhibited in second direction; and third mode where rotation is inhibited in both directions. Preferably, the resistance is applied by ratchet. Winder unit where a ratchet device and one-way bearing or clutch act in unison to control rotation of the spindle.

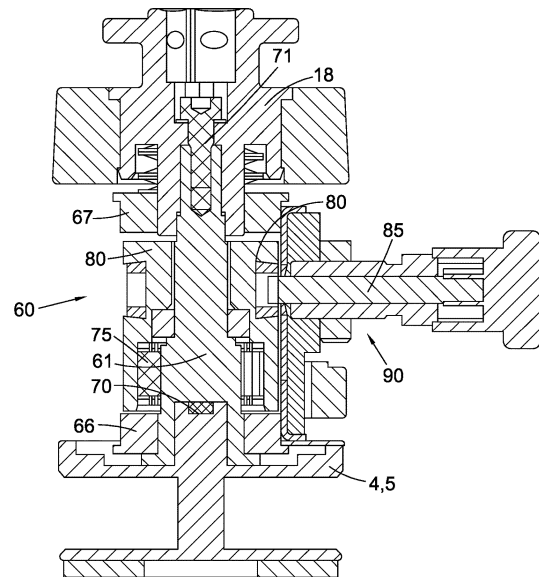

Fig. 5

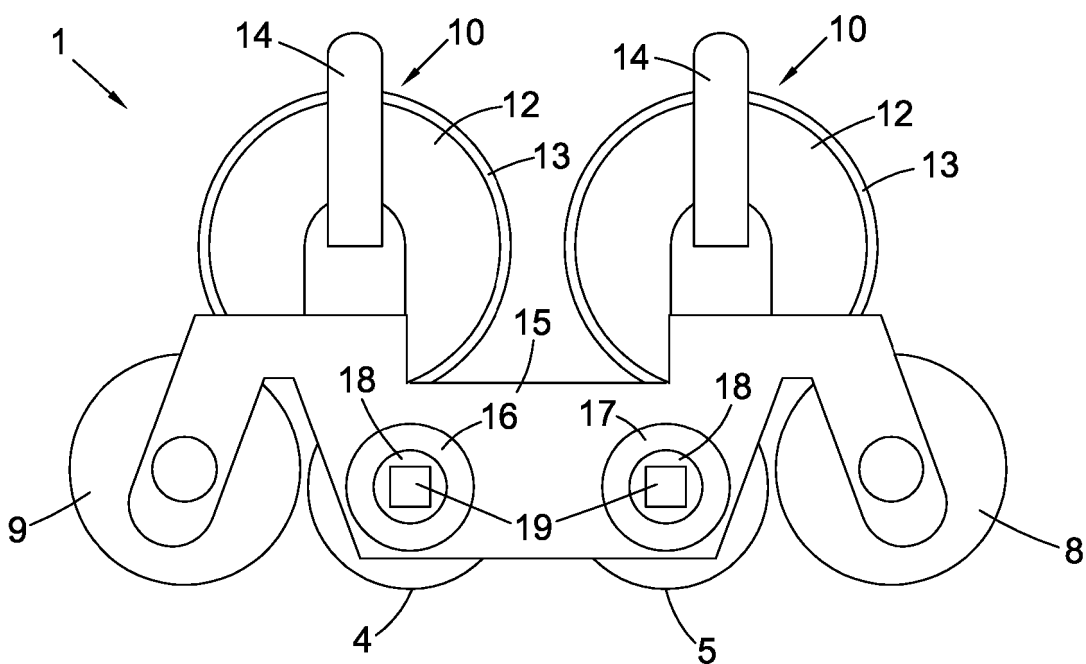
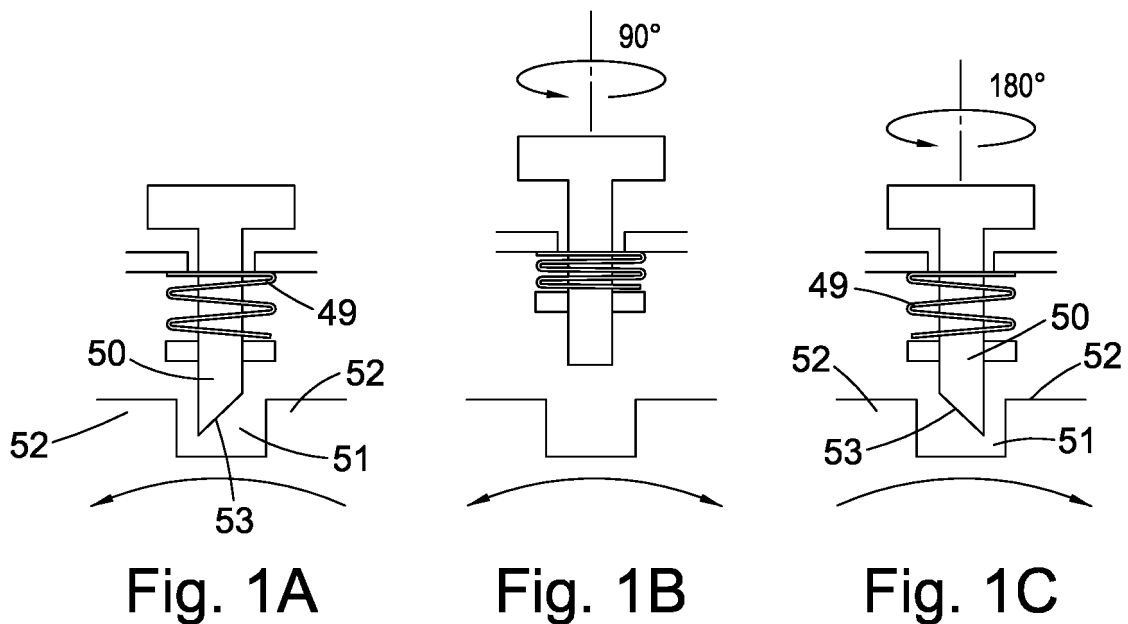

Fig. 2

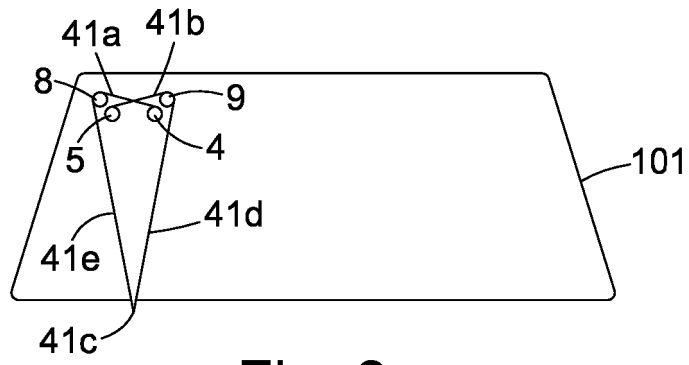

Fig. 3

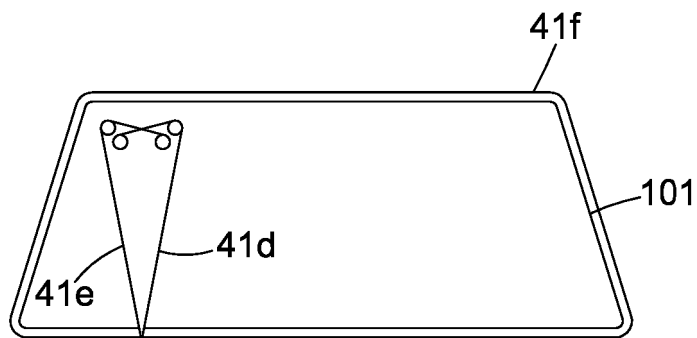

Fig. 4

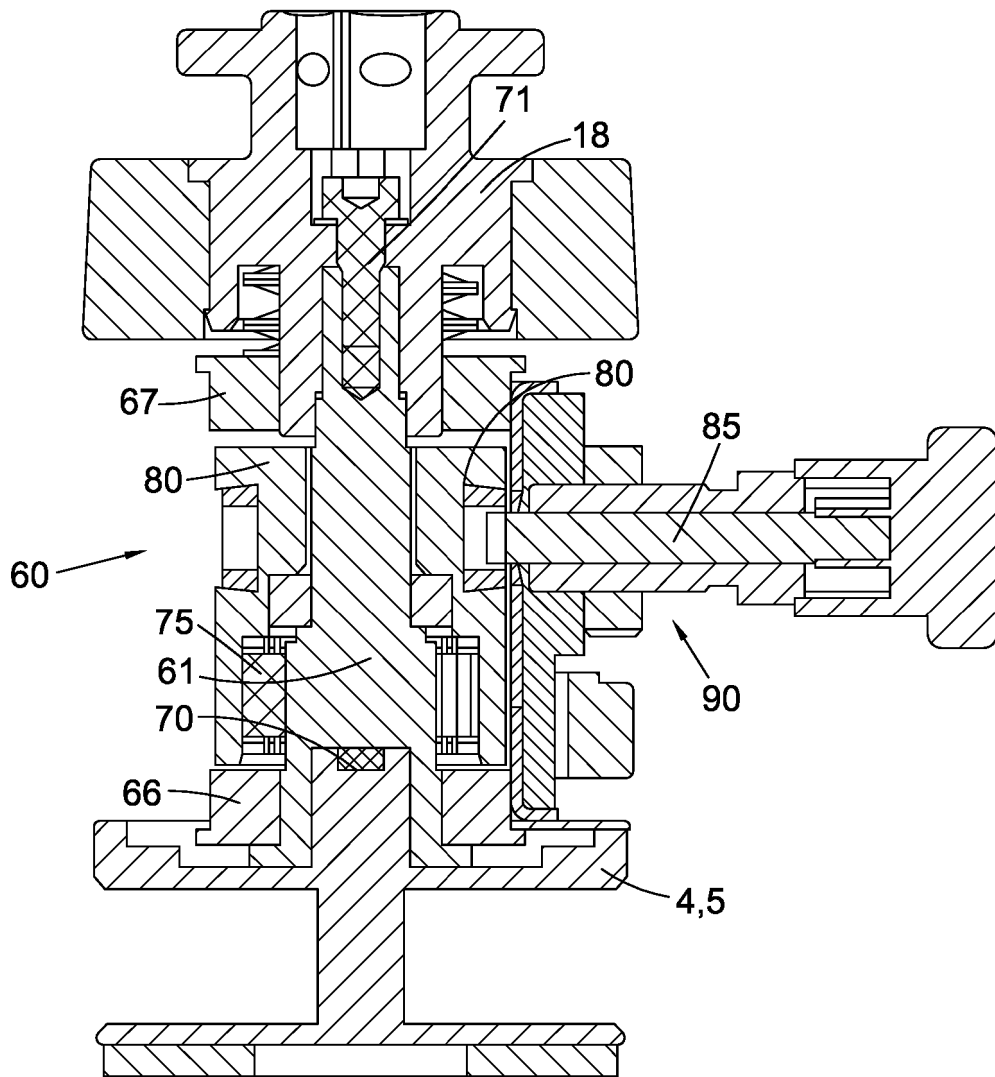

Fig. 5

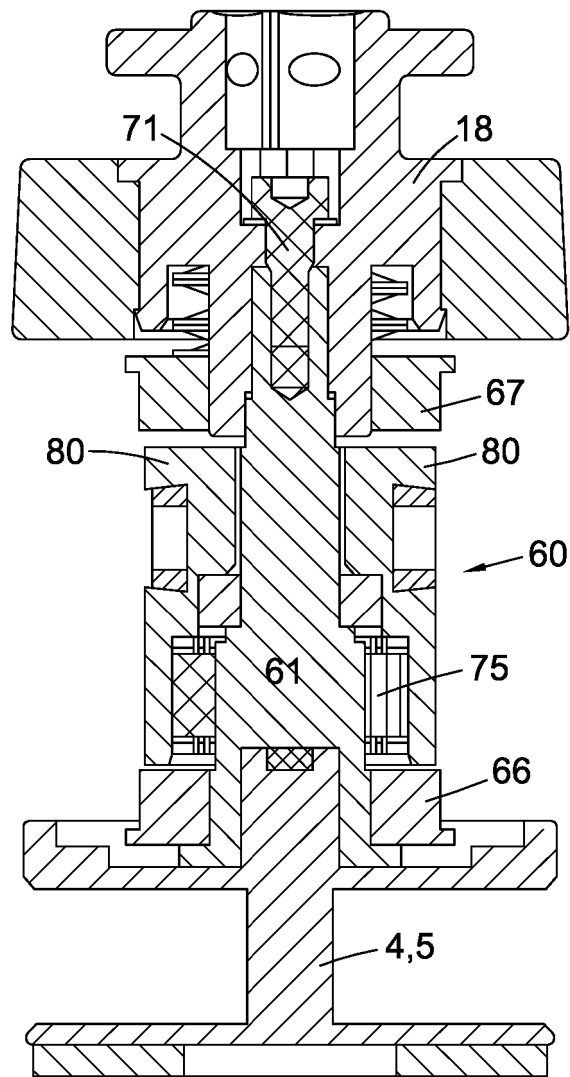

Fig. 6

5/6

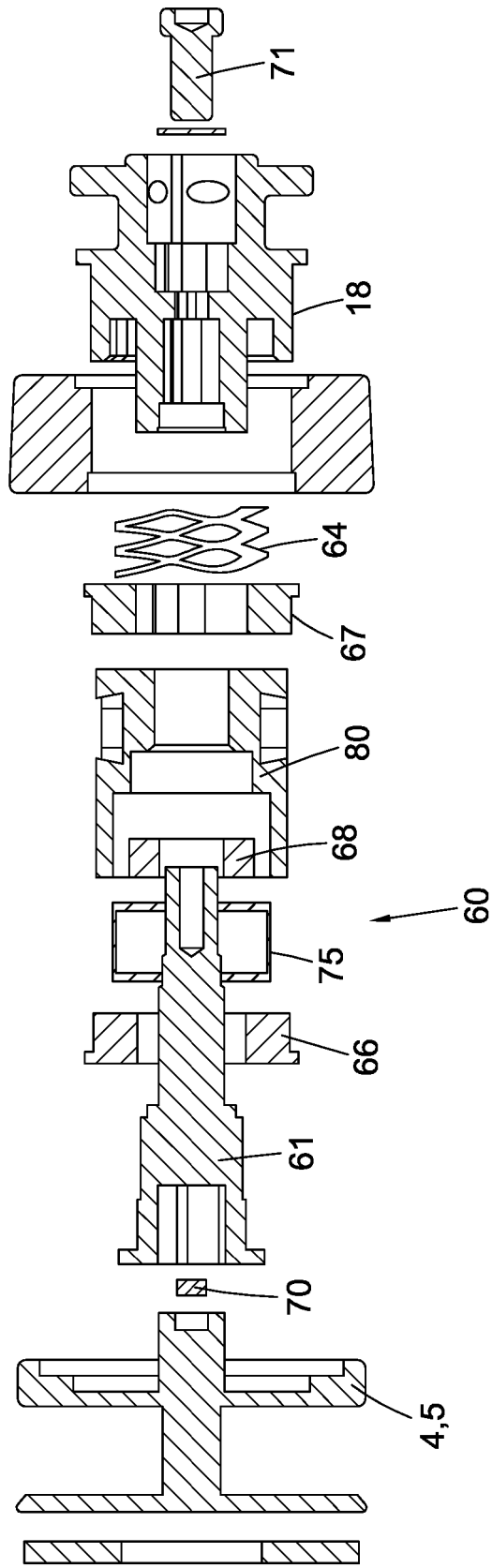

Fig. 7

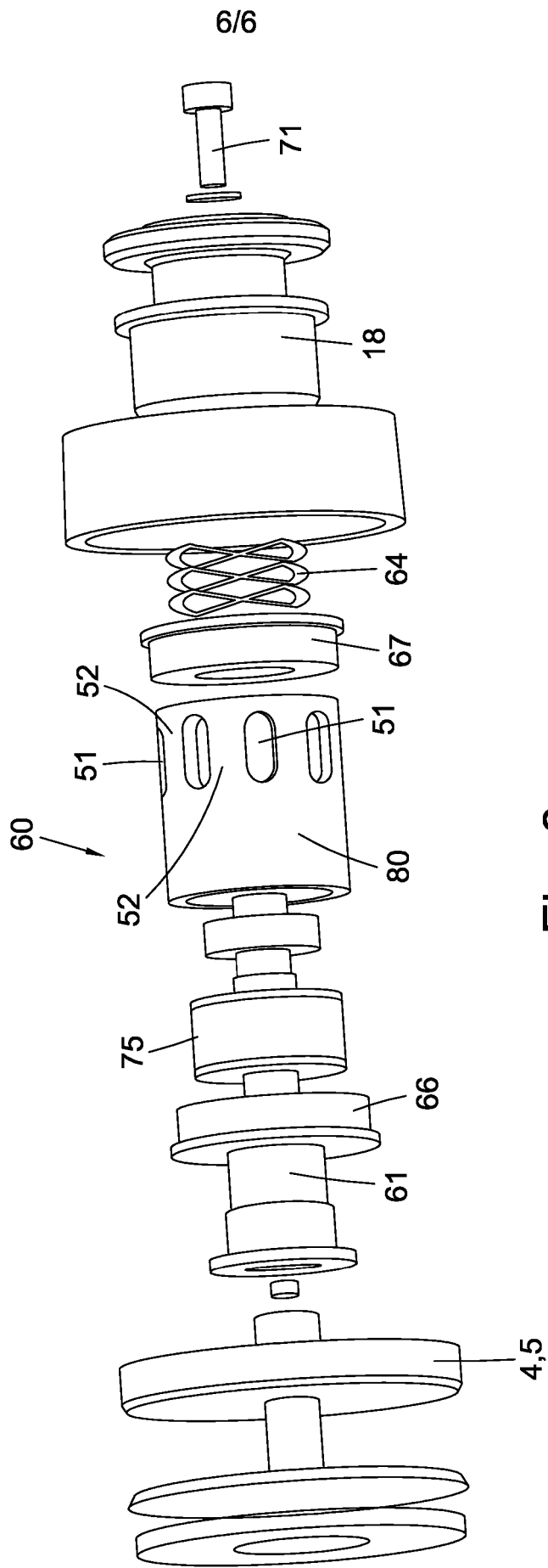

Fig. 8

Winder Unit for Vehicle Glazing Panel Cut Out

The present invention relates to a winder unit for use in a vehicle glazing panel cut out technique using a cutting line such as wire or fibre.

5

Vehicle glazing panels such as vehicle windscreens (windshields) are typically bonded in supporting frames by adhesive bonding material such as polyurethane, applied in a continuous bead about the periphery of the glazing panel and frame.

10 Wire cutting techniques have been previously proposed and used to effect glazing panel removal (for replacement or otherwise). Exemplary techniques are disclosed in, for example, EP-A-0093283, Canadian Patent Specification 2034221, US Patent 6616800, German Patent 4012207 and PCT Publications WO2006/030212, WO86/07017, WO98/58779 and GB2494548. In particular WO2006/030212 and GB2494548 disclose  
15 techniques in which, during cutting, the wire can be operated in certain circumstances to slip or slide with respect to the bonding material in order to saw or cut through the bonding material. This has proved advantageous.

WO2015/039703 discloses a technique which improves upon the earlier techniques by  
20 utilizing slip cutting in a more controlled and consistent manner. The technique can be used with cutting wire or a cutting line not of metal such as a synthetic fibre cutting line.

In the technique of WO2015/039703, a loop of the cutting line is formed around the periphery of the entire windscreen in a set up phase and the cutting line is attached at  
25 opposed ends to each of respective winders spools of the cutting device. In the cut out procedure when winding in on one of the winder spools the other is configured to allow the cutting line to be drawn off the respective spool. In other words the line is attached to both spools during the cutting procedure and slip is achieved by permitting winding off from one of the spools as the line is wound on to the other. As a result there can be constant slip  
30 cutting throughout substantially the entire process (certainly for the majority of the cut out process).



Respective winder mechanisms associated with each spool have ratchets which are toggled between a 'forward ratchet permitted' position and a 'reverse ratchet permitted' position (and a neutral ratchet off position) to enable winding onto or off a respective winder spool during the cut out procedure. In the ratchet operating positions rotation is permitted in one direction only. The ratchet as shown schematically for figures 1A to 1C comprises a spring loaded pawl which engages in teeth in a ratchet collar mounted on the drive shaft of the spool drive mechanism. The pawl is provided with an angled slip surface and the pawl can be lifted back against the spring so as to be rotated about its axis to reverse the position of the slip surface through 180 degrees. These alternative positions are the 'forward ratchet permitted' position and a 'reverse ratchet permitted' positions referred to earlier. In the configuration of fig 1A rotation is permitted in one direction only and in the other configuration (Fig 1C) the reverse direction only. It is possible to hold the ratchet in the neutral position as shown in figure 1B in which rotation is permitted in either direction.

When the ratchet is operating in either the configuration of figure 1A or figure 1C each time, in the direction of permitted rotation, the pawl lifts over the teeth as rotation is effected effectively slightly compressing the spring each time. This results in greater torque being required to effect rotation than would otherwise be the case for rotation without the ratchet.

20

US6216969B1 relates to a mechanism for enabling one-way unwinding.

An improved technique and apparatus has now been devised.

25 According to the invention, there is provided a winder unit for winding cutting line, the winder unit comprising a rotatable spindle shaft for winding; a ratchet device being mounted to the spindle shaft by means of a one-way rotational bearing or clutch.

30 According to an alternative view the invention comprises a winder unit for winding cutting line, the winder unit comprising a rotatable spindle shaft for winding; the rotatable spindle shaft being controllable to operate in:

a first mode in which the spindle is arranged to freewheel in a first rotational direction but is inhibited from rotating in the opposed direction; and/or

5 a second mode in which the spindle is arranged to be rotatable against a selectively applied resistance but is inhibited from rotating in the opposed direction; and/or,

a third mode in which the spindle is inhibited from rotating altogether.

10 According to an alternative view the invention provides a winder unit for winding cutting line, the winder unit comprising a rotatable spindle shaft for winding; operation of the rotatable spindle shaft being controlled by a ratchet device and a one-way rotational bearing or clutch.

15 According to a further alternative view, the invention provides a winder unit for winding cutting line, the winder unit comprising a rotatable spindle shaft for winding; operation of the rotatable spindle shaft being controlled by a first one-way rotational control device (for example a ratchet); and a second one way rotational control device (for example a one way bearing or clutch); both devices acting in concert to control rotation of the spindle.

20

According to any aspect, it is preferred that operation is by means of:

a first mode in which the spindle is arranged to freewheel in a first rotational direction but is inhibited from rotating in the opposed direction; and/or

25

a second mode in which the spindle is arranged to be rotatable against a selectively applied resistance but is inhibited from rotating in the opposed direction; and/or,

30

a third mode in which the spindle is inhibited from rotating altogether.

It is preferred that the ratchet device comprises a component mounted to rotate in unison with the one-way rotational bearing or clutch.

Preferably the ratchet device comprises a ratchet collar mounted to the one-way rotational bearing or clutch.

- 5 In one embodiment the one-way rotational bearing or clutch comprises a one way freewheel device.

In one embodiment the one-way rotational bearing or clutch comprises a sprag clutch.

- 10 The winder spool for the cutting line is mounted to the spindle.

It is preferred that the winder spool is demountable from the spindle. Magnetic means may be used to mount the spool to the spindle shaft.

- 15 The unit is preferably provided with mounting means for mounting the unit to a glazing panel.

The mounting means preferably comprises one or more sucker devices.

- 20 It is preferred that one or more rotatable cutting line guide pulleys are positioned spaced from the spindle.

It is preferred that the unit comprises a plurality of spindle shafts for mounting respective cutting line spools spaced from one another.

25

Beneficially, a plurality of the spindle shafts comprise a respective ratchet device being mounted to the respective spindle shaft by means of a respective one-way rotational bearing or clutch. Preferably one spindle shaft has a one way bearing or clutch device arranged to permit rotation in an opposed sense to the direction of permitted rotation of

- 30 another of the spindle shafts.

The invention will now be further described in a specific embodiment by way of example only and with reference to the accompanying drawings, in which;

5 Figures 1A to 1C show schematically a ratchet arrangement in engaged, neutral and reverse engaged positions respectively;

Figure 2 is a schematic plan view of a winder unit of an exemplary cut out system in accordance with the method of the invention;

10 Figures 3 and 4 are schematic representations in sequence of a cut out technique in accordance with the invention;

Figure 5 is a sectional view of the drive spindle and spool of the unit according to the invention with the ratchet pawl mounted in position;

15

Figure 6 is a view similar to figure 5 but with the ratchet pawl removed;

Figures 7 and 8 are exploded sectional and perspective views of the spindle of the unit according to the invention.

20

Referring to the drawings there is shown a cut out system particularly for use in cut out of bonded vehicle glazing panels such as windscreens.

25 The cut out system comprises a winder unit 1 including a pair of releasable suction cup mounts 10 enabling the winder unit to be releasably secured to the windscreen. The suction cup mounts comprise a rigid plastics cup 12 and underlying flexible rubber skirt membrane 13. Respective actuation/release levers 14 enable consistent suction to be applied and released. Such suction mounts are commonly employed in windscreen replacement and repair technology. The suction cup mounts 10 are pivotably/tiltably mounted to the  
30 support chassis 15 of the winder unit to ensure that both mounts 10 can locate in good engagement with the windscreen despite the curvature of the windscreen. The main body of the support chassis 15 carries a pair of underslung winding spools 4, 5 in side by side relationship. The spools are connected to axial spindle drive shafts which are supported in

bearings provided on the winder unit. The spools 4, 5 are driven axially rotationally either manually via a hand winder or by means of a mechanical actuator such as a motorised winding or winching tool. The manual or automatic driving tool is configured to engage with drive bosses which are provided at the opposite end of the drive shafts to the spools 4, 5. The drive shafts are compound structures comprising a number of interconnected components as will be described in detail later.

Positioned outwardly of the winding spools 4, 5 are respective wire guide pulley wheels 8, 9 of low friction plastics material. The pulley wheels are mounted to be rotatable about respective rotational axes. The guide pulleys rotate as the cutting wire is drawn tangentially across the pulleys as will be described.

To recap in the prior art the ratchet as shown schematically for figures 1A to 1C comprises a spring 49 loaded pawl 50 which engages in a recesses formed between teeth 52 in a ratchet collar mounted on the drive shaft of the spool drive mechanism. Teeth and intermediate recess for capturing the pawl 50 are provided entirely around the pawl collar. For purposes of explanation in figures 1A to 1C a single recess 51 is shown in which the pawl 50 can engage. The pawl 50 is provided with an angled slip surface 53 and the pawl can be lifted back against the spring 49 so as to be rotated about its axis to reverse the position of the slip surface through 180 degrees. These alternative positions are the 'forward ratchet permitted' position and a 'reverse ratchet permitted' positions referred to earlier. In the configuration of fig 1A rotation is permitted in one direction only and in the other configuration (Fig 1C) the reverse direction only. It is possible to hold the ratchet in the neutral position as shown in figure 1B in which rotation is permitted in either direction. Instead of 'teeth' the ratchet can comprise slots in an otherwise smooth surfaced cylinder. This is shown in the ratchet collar 80 in figure 8 which has smooth surface 52 interrupted by a series of axially extending spaced slots 51 to form the ratchet 'teeth'.

When the ratchet is operating in either the configuration of figure 1A or figure 1C each time, in the direction of permitted rotation, the pawl 50 lifts over the teeth as rotation is effected, effectively slightly compressing the spring 49 each time. This results in greater torque being required to effect rotation than would otherwise be the case for rotation without the ratchet.

The technique of WO2015/039703 seeks to improve upon prior art techniques (for example disclosed in WO2006/030212 and GB2494548 by utilizing slip cutting in a more controlled and consistent manner. In accordance with WO2015/039703, a loop of the cutting line is formed around the periphery of the entire windscreen 101 in the set up  
5 procedure and the cutting line is attached at opposed ends to each of the respective winder spools.

In setting up, the winder unit is initially provided (loaded) with a significant length of the line already wound onto the respective winder spools and positioned on the inside of the  
10 windshield. The winder spool ratchets are toggled to the ratchet position which permits the cutting line to be drawn off the respective winder spools and line is pulled off the loaded unit, separate lengths 41a 41b being drawn around pulleys 8,9 crossed over as shown in figure 2. A pinched apex 41c of the loop of line 41 is drawn out and pushed through a hole  
15 formed in the PU bonding bead. Thus the pinched apex 41c of the line 41 is drawn from inside to outside the vehicle, at a position below the winder unit 1.

Next the loop of the line is expanded and looped around the entire periphery of the windshield 101 externally of the vehicle and positioned adjacent the PU bead. This is  
20 shown in figure 3, where the unit 1 is positioned internally of the vehicle and the lengths 41d 41e are also internally but the remainder of the loop 41f is externally of the vehicle. When in position as shown in figure 3, the winder spools can be operated as described above to slip cut the PU bead and release the windscreen from the supporting frame.

25 In the cut out procedure when winding in on one of the winder spools 4, 5 the other is configured to allow the cutting line to be drawn off the respective spool. In other words the line is attached to both spools during the cutting procedure and slip is achieved by permitting winding off from one of the spools as the line is wound on to the other. As a result there can be constant slip cutting throughout substantially the entire process  
30 (certainly for the majority of the cut out process). This is achieved by means of toggling the ratchet mechanisms. The ratchets of the respective winder mechanism are toggled between a 'forward ratchet permitted' position – Fig 1A and a 'reverse ratchet permitted' - Fig 1C position (or a ratchet off/neutral position – Fig 1B) to enable winding onto or off a

respective winder spool 4, 5 during the cut out procedure. When the ratchet is operating in either the configuration of figure 1A or figure 1C each time, in the direction of permitted rotation, the pawl lifts over the teeth as rotation is effected effectively slightly compressing the spring each time. This results in greater torque being required to effect rotation than  
5 would otherwise be the case for rotation without the ratchet. More winding effort is therefore required which can be significant when added to the friction resistance caused by the line cutting through the bonding bead.

The present invention provides an improvement over the known prior art cutout devices by  
10 utilizing for the drive shaft spindle that drives the spools 4, 5 a rotational directional control mechanism which comprises 2 one-way rotational control devices cooperating in concert. For example the rotational directional control mechanism comprises a ratchet mechanism that can be selectively applied but which also comprises a one way clutch or bearing mounted to the shaft.

15 Referring to figures 5 and 6, the drive spindle 60 includes a spindle shaft 61 for mounting the spool. The spindle shaft is connected at its other end to the drive boss 18. A cylindrical stator mounts the drive spindle 60 to the chassis 15 of the winder unit. Flange bearings 66, 67 connect the stator 63 to the drive shaft spindle. A magnet 70 is provided in  
20 a recess of a quick change spool to permit mounting to the drive shaft spindle. Other means of mounting may be used. The drive boss 18 as shown is fixed using a wave spring washer 64 and a machine screw 71 to the drive shaft spindle.

A one way rotational clutch or bearing 75 mounts the ratchet collar 80 to the spindle shaft  
25 61. The ratchet collar is the item provided with the ratchet teeth and recesses extending around the collar. This feature enables rotation of the spindle shaft 61 to be governed or constrained by two means operating in concert, namely the one way clutch or bearing 75 and the ratchet mechanism (pawl 85 engaging in the slots 51 between the 'teeth' 52 on the ratchet collar 80). The one way clutch or bearing 75 acts such that torque is only  
30 transmitted between the drive shaft spindle and the mounted ratchet collar with rotation in one direction only. Such one way rotation devices are known in the art, for example as a sprag clutch or one way freewheel clutch. A sprag clutch operates in a similar way to a roller bearing, but instead of cylindrical rollers, non-revolving asymmetric figure-eight

shaped sprags are used. When the unit rotates in one direction the asymmetric sprags slip or free-wheel to enable the spindle shaft 61 to rotate in that direction, but when a torque is applied in the opposite direction, the sprags tilt slightly, producing a wedging action and binding because of friction as a frictional engagement will be formed by the wedging  
5 action of the respective sprags on the spindle shaft 61 and the ratchet collar 80 to restrict movement in the opposite direction. The sprags are usually spring-loaded so that they lock with very little backlash.

As a result of such a mounting arrangement rotation of the drive spindle shaft can be  
10 controlled by the ratchet mechanism 90 (pawl 85 and ratchet collar 80) operating in concert with the one way clutch or bearing device 75. The impact of this is:

1. With the ratchet in neutral (i.e. pawl 85 totally disengaged from the ratchet collar 80). In this condition the spindle shaft 61 can be driven to rotate in the direction  
15 permitted by the one way clutch or bearing device 75. The ratchet collar 80 is not constrained by the ratchet pawl 85 and simply rotates in unison with the one way clutch or bearing device 75, such as the sprag clutch described above, in the direction permitted by the one way clutch or bearing device, i.e. the direction permitted by the shape of the sprags which form the sprag clutch. The ratchet has  
20 no application in that it does not actively influence the movement of the spindle shaft 61 but rather moves in unison with the spindle shaft 61. The spindle shaft 61 can freely rotate in one direction (i.e. the direction permitted by the one way clutch or bearing device 75). If the cutting line is being pulled off the spool 4, 5 in this condition it is easy to do so because there is very little resistance – freewheel  
25 condition. Operation is noiseless (ratchet ‘clicks’ are not heard). This condition can be preferred for the driving spindle shaft 61 because it minimizes winding torque. The freewheeling condition can also be used for fiber line cutting when pulling off the spool as fiber line is not prone to ‘birds nesting’ as wire is. This can be described as a mode in which the spindle shaft is arranged to freewheel in a first  
30 rotational direction but is inhibited from rotating in the opposed direction. That is to say, when the cutting line is being pulled off the spool 4, 5 the spindle shaft can freely rotate in the first direction, i.e. the dispensing direction, as the sprag clutch enables the spindle shaft 61 to move in the first direction due to the free-wheel



condition of the sprag clutch. However, the movement of the spindle shaft 61 in the second direction, i.e. the opposite direction, movement of the spindle shaft 61 is inhibited by the wedging action of the respective sprags as the tilted sprags form a frictional engagement between the spindle shaft and the ratchet collar 80 which prevents movement of the spindle shaft 61.

2. In this mode, the ratchet 90 is applied and rotation of the spindle shaft 61 is permitted in the same sense as permitted by the one way bearing/clutch, i.e. the pawl 85 engages in the slots 51 between the teeth 52 on the ratchet collar and the one way clutch or bearing 75 mounts the ratchet collar 80 to the spindle shaft 61, thereby enabling the movement of the spindle shaft 61 to be influenced by the ratchet collar 80 and the pawl 85. The amount of engagement between the pawl 85 and the slots 51 can be adjusted. The higher the amount of engagement between the pawl 85 and the slot 51, the higher the amount of resistance offered by the pawl 85 to the movement of the spindle shaft 61. In this condition rotation of the spindle shaft 61 together with the one way clutch or bearing device 75 and the ratchet collar 80 is permitted in one direction but not the other (i.e. the direction permitted by the one way clutch or bearing device) but with some effect from the ratchet collar 80. The ratchet has effect so there is more resistance to rotation than in the one way freewheel state described above. The ratchet spring 49 force needs to be overcome during rotation. If the cutting line is being pulled off the spool in this condition it is less easy to do so because there is resistance in overcoming the ratchet spring force. The ratchet 'clicks' during operation. This situation can be of benefit if some resistance is required during slip cutting and also to prevent wire coming off the spool (birds nesting) under freewheel conditions during slip cutting. This can be described as a mode in which the spindle shaft is arranged to be rotatable against a selectively applied resistance. The resistance generated by the pawl 85 engaging in the slots 51 between the teeth 52 on the ratchet collar 80 and applying a small, but not an insurmountable, amount of resistance to the movement of the spindle shaft 61 in the first direction mean that movement of the spindle shaft 61 in the first direction is enabled – with some clicking. The mounting of the ratchet collar 80 to the spindle shaft 61 by way of the one way clutch or bearing 75 as described above means that movement of the spindle shaft in a second direction

(a direction opposite to the first direction) is inhibited by the wedging action of the sprags which forms a frictional engagement between the sprags, the spindle shaft 61 and the ratchet collar 80.

- 5           3. With the ratchet 90 applied permitting rotation in the opposite sense permitted by the one way bearing/clutch 75. In this condition the ratchet (pawl 85 and collar 80) inhibits rotation in one direction and the one way clutch or bearing device prevents rotation in the other direction. The spindle is held against rotation in either direction. This can be described as a mode in which the spindle is inhibited from  
10           rotating altogether.

The drive shaft spindles 61 for the separate respective spools 4, 5 have one way bearing or clutch devices arranged to permit rotation in opposed senses.

- 15       The unit according to the invention having the rotational directional control mechanism which comprises 2 one-way rotational control devices cooperating in concert, provides technical superiority over known prior art winder units for cutting out glazing panels units.

Claims:

1. A winder unit for winding cutting line, the winder unit comprising a rotatable spindle shaft for winding; a ratchet device being mounted to the spindle shaft by means of a one-way rotational bearing or clutch.  
5
2. A winder unit according to claim 1, wherein the ratchet device comprises a component mounted to rotate in unison with the one-way rotational bearing or clutch.  
10
3. A winder unit according to claim 1 or claim 2 wherein the ratchet device comprises a ratchet collar mounted to the one-way rotational bearing or clutch.  
15
4. A winder unit according to any preceding claim, wherein the one-way rotational bearing or clutch comprises a one way freewheel device.  
20
5. A winder unit according to any preceding claim, wherein the one-way rotational bearing or clutch comprises a sprag clutch.  
25
6. A winder unit according to any preceding claim, wherein a winder spool for the cutting line is mounted to the spindle.  
30
7. A winder unit according to claim 6, wherein the winder spool is demountable from the spindle.  
35
8. A winder unit according to any preceding claim including mounting means for mounting the unit to a glazing panel.
9. A winder unit according to claim 8, wherein the mounting means comprises one or more sucker devices.
10. A winder unit according to any preceding claim, wherein one or more rotatable cutting line guide pulleys are positioned spaced from the spindle.
11. A winder unit according to any preceding claim comprising a plurality of spindle shafts for mounting respective cutting line spools spaced from one another.

12. A winder unit according to claim 11, wherein a plurality of the spindle shafts comprise a respective ratchet device being mounted to the respective spindle shaft by means of a respective one-way rotational bearing or clutch.

5

13. A winder unit according to claim 12, wherein one spindle shaft has a one way bearing or clutch device arranged to permit rotation in an opposed sense to the direction of permitted rotation of another of the spindle shafts.

10

14. A winder unit for winding cutting line, the winder unit comprising a rotatable spindle shaft for winding; the rotatable spindle shaft being controllable to operate in:

15

a first mode in which the spindle is arranged to freewheel in a first rotational direction but is inhibited from rotating in the opposed direction; and/or

a second mode in which the spindle is arranged to be rotatable against a selectively applied resistance but is inhibited from rotating in the opposed direction; and/or,

20

a third mode in which the spindle is inhibited from rotating altogether.

15. A winder unit according to claim 14, wherein in the second mode, the selectively applied resistance is applied by a ratchet mechanism.

25

16. A winder unit for winding cutting line, the winder unit comprising a rotatable spindle shaft for winding; operation of the rotatable spindle shaft being controlled by a ratchet device and a one-way rotational bearing or clutch.

30

17. A winder unit according to claim 16 wherein the ratchet device acts on the one-way rotational bearing or clutch to control operation of the spindle shaft.

18. A winder unit according to claim 17 or claim 16, wherein the ratchet device and a one-way rotational bearing or clutch cooperate in:

35

a first mode in which the spindle is arranged to freewheel in a first rotational direction but is inhibited from rotating in the opposed direction; and/or

5 a second mode in which the spindle is arranged to be rotatable against a selectively applied resistance but is inhibited from rotating in the opposed direction; and/or,

a third mode in which the spindle is inhibited from rotating altogether.

10 19. A winder unit for winding cutting line, the winder unit comprising a rotatable spindle shaft for winding; operation of the rotatable spindle shaft being controlled by a first one-way rotational control device; and a second one way rotational control device; both devices acting in concert to control rotation of the spindle.



**Application No:** GB1701069.5

**Examiner:** Mr Peter Banks

**Claims searched:** 1-13

**Date of search:** 25 April 2017

**Patents Act 1977: Search Report under Section 17**

**Documents considered to be relevant:**

Category	Relevant to claims	Identity of document and passage or figure of particular relevance
X	1-7	US6216969 B (YAMAGUCHI). See fig. 7 and column 10, lines 32-59.
A		GB2489835 A (VAUGHAN). See page 13, second paragraph.
A		GB2526308 A (BELRON)
A		WO2011/101667 A (BELRON).

**Categories:**

X	Document indicating lack of novelty or inventive step	A	Document indicating technological background and/or state of the art.
Y	Document indicating lack of inventive step if combined with one or more other documents of same category.	P	Document published on or after the declared priority date but before the filing date of this invention.
&	Member of the same patent family	E	Patent document published on or after, but with priority date earlier than, the filing date of this application.

**Field of Search:**

Search of GB, EP, WO & US patent documents classified in the following areas of the UKC<sup>X</sup> :

--

Worldwide search of patent documents classified in the following areas of the IPC

B23D; B26B; B26D
------------------

The following online and other databases have been used in the preparation of this search report

WPI, EPODOC, TXTA
-------------------

**International Classification:**

Subclass	Subgroup	Valid From
B26D	0001/547	01/01/2006
B26B	0027/00	01/01/2006