

(19) World Intellectual Property
Organization
International Bureau



(43) International Publication Date
2 December 2004 (02.12.2004)

PCT

(10) International Publication Number
WO 2004/103567 A1

(51) International Patent Classification⁷: **B02C 7/12**,
D21B 1/14

(21) International Application Number:
PCT/SE2004/000678

(22) International Filing Date: 5 May 2004 (05.05.2004)

(25) Filing Language: English

(26) Publication Language: English

(30) Priority Data:
0301525-2 23 May 2003 (23.05.2003) SE

(71) Applicant (for all designated States except US): **METSO PAPER, INC** [FI/FI]; P.O. Box 1220, FIN-00101 Helsinki (FI).

(72) Inventor; and

(75) Inventor/Applicant (for US only): **VIRVING, Nils** [SE/SE]; Backtimjegränd 27, S-165 73 Hässelby (SE).

(74) Agent: **SUNDQVIST, Hans**; Metso Paper Sundsvall AB, S-851 94 Sundsvall (SE).

(81) Designated States (unless otherwise indicated, for every kind of national protection available): AE, AG, AL, AM,

AT, AU, AZ, BA, BB, BG, BR, BW, BY, BZ, CA, CH, CN, CO, CR, CU, CZ, DE, DK, DM, DZ, EC, EE, EG, ES, FI, GB, GD, GE, GH, GM, HR, HU, ID, IL, IN, IS, JP, KE, KG, KP, KR, KZ, LC, LK, LR, LS, LT, LU, LV, MA, MD, MG, MK, MN, MW, MX, MZ, NA, NI, NO, NZ, OM, PG, PH, PL, PT, RO, RU, SC, SD, SE, SG, SK, SL, SY, TJ, TM, TN, TR, TT, TZ, UA, UG, US, UZ, VC, VN, YU, ZA, ZM, ZW.

(84) Designated States (unless otherwise indicated, for every kind of regional protection available): ARIPO (BW, GH, GM, KE, LS, MW, MZ, NA, SD, SL, SZ, TZ, UG, ZM, ZW), Eurasian (AM, AZ, BY, KG, KZ, MD, RU, TJ, TM), European (AT, BE, BG, CH, CY, CZ, DE, DK, EE, ES, FI, FR, GB, GR, HU, IE, IT, LU, MC, NL, PL, PT, RO, SE, SI, SK, TR), OAPI (BF, BJ, CF, CG, CI, CM, GA, GN, GQ, GW, ML, MR, NE, SN, TD, TG).

Declaration under Rule 4.17:

— of inventorship (Rule 4.17(iv)) for US only

Published:

— with international search report

For two-letter codes and other abbreviations, refer to the "Guidance Notes on Codes and Abbreviations" appearing at the beginning of each regular issue of the PCT Gazette.

(54) Title: REFINING ELEMENT

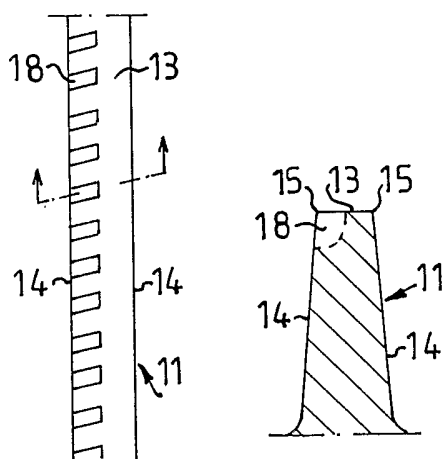

(57) Abstract: Refining element intended for refiners of disc-type for working fibrous material, where the refining element (10) is formed with a pattern of bars (11) with upper surfaces (13) and side surfaces (14) and intermediate grooves (12). A plurality of recesses (18) are arranged one after the other in longitudinal edges (15) of the bars (11), which recesses are open both to the upper surface (13) and one side surface (14) of the bars.

WO 2004/103567 A1

Refining element

This invention relates to refiners of disc-type with opposed refining discs rotating relative to one another. The refining discs are provided with refining elements, which between themselves form a refining gap with a refining zone for working fibrous material. The fibrous material preferably is lignocellulosic fibrous material and the refiner is used for the manufacture of, for example, reject pulp, recycled fibre pulp and mechanical pulps, such as board pulp, thermomechanical pulp (TMP) and chemi-thermo-mechanical pulp (CTMP) and for low-concentration refining chemical pulps.

The invention, more precisely, relates to a refining element for use in a refiner of the above kind.

A refining element is formed with a pattern of bars and intermediate grooves. The bars and grooves are formed in different ways, depending on which fibrous material is worked and which refining degree and, thus, in the case of lignocellulosic material, which pulp quality are desired. The bars have an upper surface and side surfaces so that longitudinal edges are formed between the upper surface and respective side surface. The bars can be, for example, continuous or discontinuous and be arranged in different patterns. The working of the fibrous material substantially is carried out by the bars of the refining elements. The refining gap is formed so that the fibrous material, seen in radial direction, shall pass from the inside outward. Farthermost inward in the refining gap the refining elements normally are formed so as to bring about a first disintegration of the material and to advance the material outward in the refining gap. A certain defibering, i.e. separation of the fibers of the lignocellulosic material, also takes place in the inner portion of the refining gap where the distance between the refining surfaces is the greatest. Thereafter the distance decreases outward in order that the desired working or refining of the fibrous material shall be obtained.

At the refining of fibrous material of high concentration, and above all at high energy inputs, it was found necessary to place flow restrictions, so-called dams, in the grooves of the refining elements in order to prevent unworked material from passing out through the refining gap. These dams, however, form an obstacle for the steam developing in the refining gap during the refining. A high steam pressure is thereby created in the

refining gap. The high steam pressure has a negative effect on the capacity and operational stability of the refiner. It also implies a limitation of the possible energy input. The developed steam, thus, will be forced by the flow restrictions upward out of the grooves and disturb the material flow through the refining gap.

One way of solving this problem would be to supply dilution water to the refining gap in order thereby to condense the steam. This, however, results in reducing the material concentration to a low level and thereby deteriorated pulp quality.

At the working or refining of fibrous material with low concentration no steam development takes place, and the material is transported partially by the liquid flow out of the refining gap. Also here usually dams are used to prevent unworked material from passing out through the refining gap. It can imply, however, that the flow through the refining gap will be much too low.

The present invention offers a solution of the above problems. According to the invention, the bars are provided with a plurality of recesses, which are arranged in the longitudinal edges of the bars. The recesses shall be directed across the bars or so as to form an angle of at least 45° with the bars. The recesses are open both to the upper surface of the bars and to one side surface or both side surfaces. By this configuration of the bars the flow of the fibrous material through the refining gap will be braked, so that the stay-time of the fibers in the refining gap will be longer and the working thereby be increased, without braking the steam or liquid flow in the grooves between the bars so that the flow of the fibrous material is disturbed.

The recesses can be placed, for example, along the entire length of the bars or be broken off by small portions without recesses, counted in the longitudinal direction of the bars. Each recess can have a constant or varying depth along the bars in the upper surface and side surfaces of the bars. The recesses can be formed only on one side or on both sides of the bars.

When the recesses are formed only on one side of the bars, the rotation direction of the refining discs carrying the refining elements cannot be changed. Such a configuration, however, can still be suitable with a view to strength.

The characterizing features of the invention are apparent from the attached claims.

The invention is described in greater detail in the following, with reference to the accompanying Figures illustrating some embodiments of the invention.

Fig. 1 shows the front side of a refining segment with a pattern of bars and intermediate grooves;

Figs. 2 and 3 show the upper surface of the bars with different configurations;

Figs. 4 and 5 are cross-sections of two alternatives according to Fig. 2.

In Fig. 1 is shown a refining element 10 intended for refining fibrous material with high concentration. The refining element 10 is provided with a pattern of bars 11 and intermediate grooves 12, where the bars have upper surfaces 13 and side surfaces 14 with edges 15. The pattern is divided into two zones, an inner zone 16 and an outer zone 17, where the bars and grooves in the inner zone are coarser than in the outer zone. The bars in the inner zone are intended to bring about a first disintegration of the material and to advance the material outward to the outer zone. The bars in the outer zone are placed more tightly, which yields more bar edges for effecting the substantial working and refining of the material. The pattern can also comprise more zones, where the pattern usually is made tighter from zone to zone, seen radially outward.

In Fig. 2 is shown an embodiment of a bar 11 on a refining element according to the invention. Along the bar 11 a plurality of recesses 18 are placed. The recesses are arranged slightly angular in relation to the longitudinal direction of the bars and are open both to the upper surface 13 and side surface 14. The recesses suitably can extend to about the centre of the upper surface of the bar. The depth of the recesses, counted from the edge, shall be one or some millimetres, preferably 2-5 mm. The width should also be one or some millimetres, preferably 2-5 mm. Bars thereby get toothed edges. The distance between adjacent recesses should be 1-10 mm, preferably 2-5 mm.

In Fig. 3 is shown another embodiment of a bar 11. Differently from Fig. 2 the recesses 18 are here placed in both edges 15 of the bar, so that both edges of the bar are

toothed. As regards the configuration of the recesses, the same dimensions apply as in Fig. 2. The recesses on opposed edges 15 are in this case suitably offset, so that they do not lie directly in front of each other. This implies that a refining element with such bars can rotate in both directions.

The form of the bottom of the recesses 18 can be rectilinear, as shown in Fig. 4, or curved, as shown in Fig. 5. Other forms, of course, can be imagined. The recesses shall be arranged across the bars or form an angle of at least 45° with the longitudinal direction of the bars. This applies above all to the surface, which outwardly defines a recess 18, counted in the flow direction of the material. When the recesses 18 are angular, they should extend from the side surfaces 14 obliquely outward, counted in the flow direction of the material.

Bars with a configuration according to the invention can be placed on any zone on the refining element, but preferably in an outer zone where the working and refining are most intensive and the distance between opposed refining elements is the shortest, i.e. the refining gap is the smallest and the steam development the greatest.

The invention, of course, is not restricted to the embodiments shown, but can be varied within the scope of the claims with reference to description and Figures.

Claims

1. A refining element intended for refiners of disc-type for working fibrous material, where the refining element (10) is formed with a pattern of bars (11) with upper surfaces (13) and side surfaces (14) and intermediate grooves (12), **characterized in** that a plurality of recesses (18) are arranged one after the other in longitudinal edges (15) of the bars (11), that the recesses are open both to the upper surface (13) and one side surface (14) of the bars.
2. A refining element as defined in claim 1, **characterized in** that the recesses (18) are provided only on one side of the bars (11).
3. A refining element as defined in claim 1, **characterized in** that the recesses (18) are provided on both sides of the bars (11).
4. A refining element as defined in any one of the preceding claims, **characterized in** that the recesses (18) extend inward to about the centre of the upper surface (13) of the bars.
5. A refining element as defined in any one of the preceding claims, **characterized in** that the recesses (18) have a depth of 2-5 mm, counted from the edge (15) of the bar.
6. A refining element as defined in any one of the preceding claims, **characterized in** that the recesses (18) have a width of 2-5 mm.
7. A refining element as defined in any one of the preceding claims, **characterized in** that the distance between recesses (18) is 1-10 mm.
8. A refining element as defined in any one of the preceding claims, **characterized in** that the recesses (18), counted in the flow direction of the material, form an angle of between 45° and 90° with the bar (11).
9. A refining element as defined in claim 5, **characterized in** that the recesses (18) are arranged substantially across the bars (11).

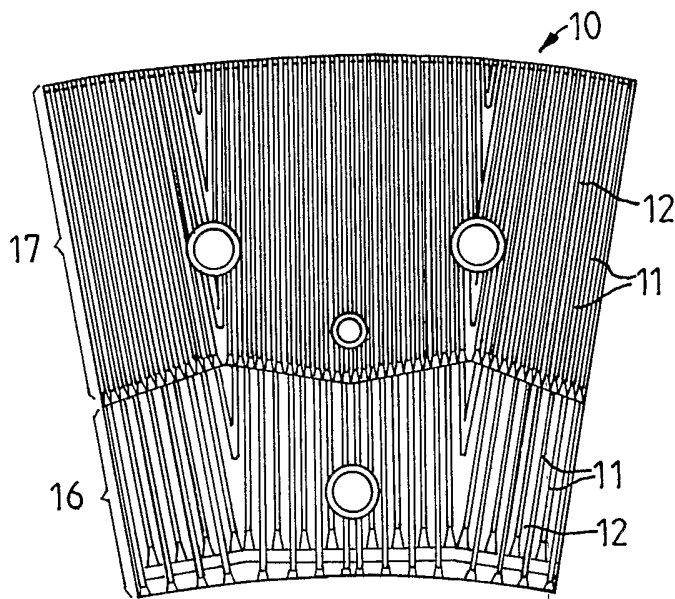

FIG. 1

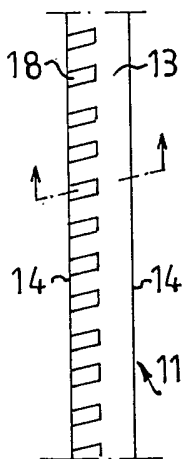

FIG. 2

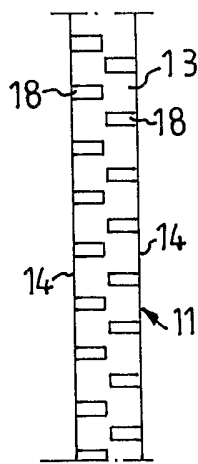

FIG. 3

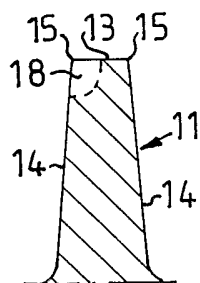

FIG. 4

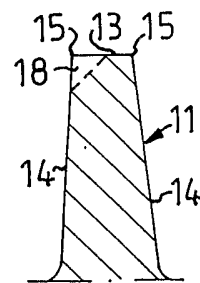

FIG. 5

INTERNATIONAL SEARCH REPORT

International application No.

PCT/SE 2004/000678

A. CLASSIFICATION OF SUBJECT MATTER

IPC7: B02C 7/12, D21B 1/14, D21D 1/30

According to International Patent Classification (IPC) or to both national classification and IPC

B. FIELDS SEARCHED

Minimum documentation searched (classification system followed by classification symbols)

IPC7: B02C, D21B, D21D

Documentation searched other than minimum documentation to the extent that such documents are included in the fields searched

SE,DK,FI,NO classes as above

Electronic data base consulted during the international search (name of data base and, where practicable, search terms used)

EPO-INTERNAL, WPI DATA, PAJ

C. DOCUMENTS CONSIDERED TO BE RELEVANT

Category*	Citation of document, with indication, where appropriate, of the relevant passages	Relevant to claim No.
X	SE 513807 C2 (VALMET FIBERTECH AB), 6 November 2000 (06.11.2000), page 4, line 2 - line 13, figures 1-4,6, claim 1, abstract	1-8
A	--	9
X	US 5467931 A (JOHN DODD), 21 November 1995 (21.11.1995), column 1, line 5 - line 8; column 2, line 52 - line 54; column 4, line 51 - line 62, figures 6,7, claims 1-8, abstract	1,3,5-9
A	--	
A	US 5165592 A (PAUL WASIKOWSKI), 24 November 1992 (24.11.1992), figures 1-5, claims 1-10, abstract	1-9
	--	

 Further documents are listed in the continuation of Box C.

 See patent family annex.

* Special categories of cited documents:

"A" document defining the general state of the art which is not considered to be of particular relevance

"E" earlier application or patent but published on or after the international filing date

"L" document which may throw doubts on priority claim(s) or which is cited to establish the publication date of another citation or other special reason (as specified)

"O" document referring to an oral disclosure, use, exhibition or other means

"P" document published prior to the international filing date but later than the priority date claimed

"T" later document published after the international filing date or priority date and not in conflict with the application but cited to understand the principle or theory underlying the invention

"X" document of particular relevance: the claimed invention cannot be considered novel or cannot be considered to involve an inventive step when the document is taken alone

"Y" document of particular relevance: the claimed invention cannot be considered to involve an inventive step when the document is combined with one or more other such documents, such combination being obvious to a person skilled in the art

"&" document member of the same patent family

Date of the actual completion of the international search

20 August 2004

Date of mailing of the international search report

25-08-2004

Name and mailing address of the ISA/

Swedish Patent Office
Box 5055, S-102 42 STOCKHOLM
Facsimile No. +46 8 666 02 86

Authorized officer

Fredrik Andersson/MP
Telephone No. +46 8 782 25 00

INTERNATIONAL SEARCH REPORT

International application No.

PCT/SE 2004/000678

C (Continuation). DOCUMENTS CONSIDERED TO BE RELEVANT		
Category*	Citation of document, with indication, where appropriate, of the relevant passages	Relevant to claim No.
A	US 4023737 A (PHILIP J. LEIDER ET AL), 17 May 1977 (17.05.1977), figures 1-4, claims 1-8, abstract --	1-9
A	FI 53469 A (ENSO-GUTZEIT OSAKEYHTIÖ), 31 January 1978 (31.01.1978), figures 1-4, claims 1-7 --	1-9
A	US 5690286 A (JOHN DODD ET AL), 25 November 1997 (25.11.1997), figures 1-19, claims 1-13, abstract -- -----	1-9

INTERNATIONAL SEARCH REPORT

Information on patent family members

03/07/2004

International application No.

PCT/SE 2004/000678

SE	513807	C2	06/11/2000	AU	760157	B	08/05/2003
				AU	4154000	A	09/10/2000
				BR	0009123	A	18/12/2001
				CA	2362667	A	28/09/2000
				CN	1344181	T	10/04/2002
				EP	1185369	A	13/03/2002
				JP	2002540298	T	26/11/2002
				NO	20014525	A	15/11/2001
				NZ	513997	A	28/03/2003
				SE	9901020	A	20/09/2000
				US	6592062	B	15/07/2003
				WO	0056459	A	28/09/2000

US	5467931	A	21/11/1995	AU	1406995	A	04/09/1995
				WO	9522653	A	24/08/1995
				ZA	9501416	A	10/01/1996

US	5165592	A	24/11/1992	NONE			

US	4023737	A	17/05/1977	NONE			

FI	53469	A	31/01/1978	NONE			

US	5690286	A	25/11/1997	CA	2185312	A,C	28/03/1997
				JP	9111683	A	28/04/1997
				US	5868330	A	09/02/1999
