

(19) World Intellectual Property Organization
International Bureau



(43) International Publication Date
10 May 2002 (10.05.2002)

PCT

(10) International Publication Number
WO 02/37475 A1

- (51) International Patent Classification⁷: **G10L 19/00** (FI). **ROTOLA-PUKKILA, Jani**; Lehvankatu 24 E 44, FIN-33820 Tampere (FI).
 - (21) International Application Number: PCT/IB01/02021
 - (22) International Filing Date: 29 October 2001 (29.10.2001)
 - (25) Filing Language: English
 - (26) Publication Language: English
 - (30) Priority Data:
09/702,540 31 October 2000 (31.10.2000) US
 - (71) Applicant: **NOKIA CORPORATION** [FI/FI]; Keilalahdentie 4, FIN-02150 Espoo (FI).
 - (71) Applicant (for LC only): **NOKIA INC.** [US/US]; 6000 Connection Drive, Irving, TX 75039 (US).
 - (72) Inventors: **MÄKINEN, Jari**; Tammelan Puistokatu 30-32 C52, FIN-33100 Tampere (FI). **MIKKOLA, Hannu, J.**; Ippisenkatu 15, FIN-33300 Tampere (FI). **VAINIO, Janne**; Laurintie 16 C, FIN-33880 Lempäälä
 - (74) Agent: **MAGUIRE, Francis, J.**; Ware, Fressola, Van Der Sluys & Adolphson LLP, 755 Main Street, P.O. Box 224, Monroe, CT 06468 (US).
 - (81) Designated States (national): AE, AG, AL, AM, AT, AU, AZ, BA, BB, BG, BR, BY, BZ, CA, CH, CN, CO, CR, CU, CZ, DE, DK, DM, DZ, EC, EE, ES, FI, GB, GD, GE, GH, GM, HR, HU, ID, IL, IN, IS, JP, KE, KG, KP, KR, KZ, LC, LK, LR, LS, LT, LU, LV, MA, MD, MG, MK, MN, MW, MX, MZ, NO, NZ, PH, PL, PT, RO, RU, SD, SE, SG, SI, SK, SL, TJ, TM, TR, TT, TZ, UA, UG, UZ, VN, YU, ZA, ZW.
 - (84) Designated States (regional): ARIPO patent (GH, GM, KE, LS, MW, MZ, SD, SL, SZ, TZ, UG, ZW), Eurasian patent (AM, AZ, BY, KG, KZ, MD, RU, TJ, TM), European patent (AT, BE, CH, CY, DE, DK, ES, FI, FR, GB, GR, IE, IT, LU, MC, NL, PT, SE, TR), OAPI patent (BF, BJ, CF, CG, CI, CM, GA, GN, GQ, GW, ML, MR, NE, SN, TD, TG).
- Published:**
— with international search report

[Continued on next page]

(54) Title: METHOD AND SYSTEM FOR SPEECH FRAME ERROR CONCEALMENT IN SPEECH DECODING

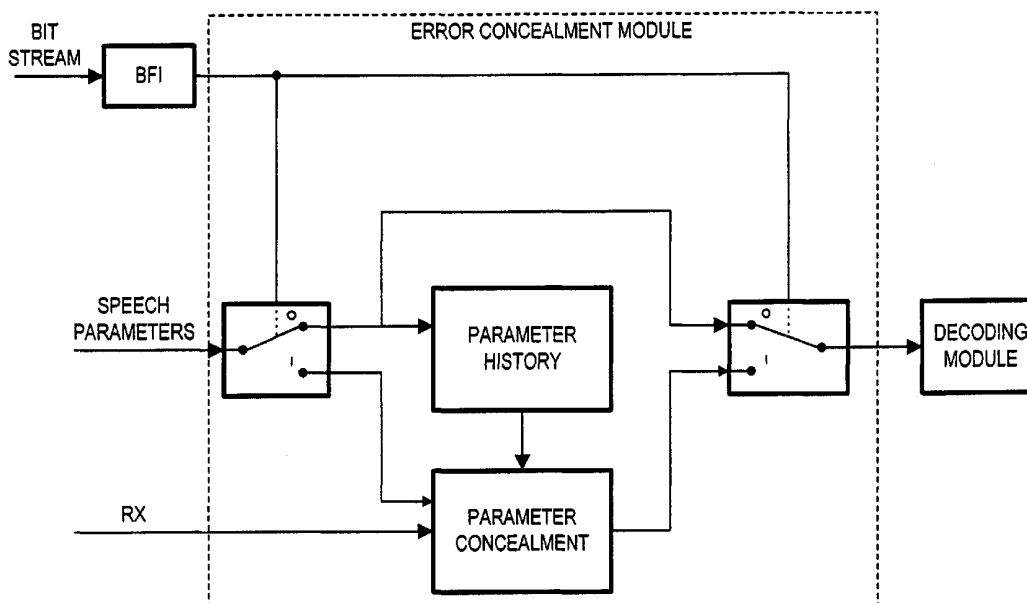

(57) Abstract: A method and system for concealing errors in one or more bad frames in a speech sequence as part of an encoded bit stream received in a decoder. When the speech sequence is voiced, the LTP-parameters in the bad frames are replaced by the corresponding parameters in the last frame. When the speech sequence is unvoiced, the LTP-parameters in the bad frames are replaced by values calculated based on the LTP history along with an adaptively-limited random term.

WO 02/37475 A1



— *before the expiration of the time limit for amending the claims and to be republished in the event of receipt of amendments*

For two-letter codes and other abbreviations, refer to the "Guidance Notes on Codes and Abbreviations" appearing at the beginning of each regular issue of the PCT Gazette.

METHOD AND SYSTEM FOR SPEECH FRAME ERROR CONCEALMENT IN SPEECH DECODING

Field of the Invention

5 The present invention relates generally to the decoding of speech signals from an encoded bit stream and, more particularly, to the concealment of corrupted speech parameters when errors in speech frames are detected during speech decoding.

Background of the Invention

10 Speech and audio coding algorithms have a wide variety of applications in communication, multimedia and storage systems. The development of the coding algorithms is driven by the need to save transmission and storage capacity while maintaining the high quality of the synthesized signal. The complexity of the coder is limited by, for example, the processing power of the application platform. In some
15 applications, for example, voice storage, the encoder may be highly complex, while the decoder should be as simple as possible.

 Modern speech codecs operate by processing the speech signal in short segments called frames. A typical frame length of a speech codec is 20 ms, which corresponds to 160 speech samples, assuming an 8 kHz sampling frequency. In the wide band codecs,
20 the typical frame length of 20 ms corresponds to 320 speech samples, assuming a 16 kHz sampling frequency. The frame may be further divided into a number of sub-frames. For every frame, the encoder determines a parametric representation of the input signal. The parameters are quantized and transmitted through a communication channel (or stored in a storage medium) in a digital form. The decoder produces a synthesized speech signal
25 based on the received parameters, as shown in Figure 1.

 A typical set of extracted coding parameters includes spectral parameters (such as Linear Predictive Coding (LPC) parameters) to be used in short term prediction of the signal, parameters to be used for long term prediction (LTP) of the signal, various gain parameters, and excitation parameters. The LTP parameter is closely related to the
30 fundamental frequency of the speech signal. This parameter is often known as a so-called pitch-lag parameter, which describes the fundamental periodicity in terms of speech samples. Also, one of the gain parameters is very much related to the fundamental periodicity and so it is called LTP gain. The LTP gain is a very important parameter in

making the speech as natural as possible. The description of the coding parameters above fits in general terms with a variety of speech codecs, including the so-called Code-Excited Linear Prediction (CELP) codecs, which have for some time been the most successful speech codecs.

5 Speech parameters are transmitted through a communication channel in a digital form. Sometimes the condition of the communication channel changes, and that might cause errors to the bit stream. This will cause frame errors (bad frames), i.e., some of the parameters describing a particular speech segment (typically 20 ms) are corrupted. There are two kinds of frame errors: totally corrupted frames and partially corrupted frames.

10 These frames are sometimes not received in the decoder at all. In the packet-based transmission systems, like in normal internet connections, the situation can arise when the data packet will never reach the receiver, or the data packet arrives so late that it cannot be used because of the real time nature of spoken speech. The partially corrupted frame is a frame that does arrive to the receiver and can still contain some parameters that are not in

15 error. This is usually the situation in a circuit switched connection like in the existing GSM connection. The bit-error rate (BER) in the partially corrupted frames is typically around 0.5-5%.

 From the description above, it can be seen that the two cases of bad or corrupted frames will require different approaches in dealing with the degradation in reconstructed

20 speech due to the loss of speech parameters.

 The lost or erroneous speech frames are consequences of the bad condition of the communication channel, which causes errors to the bit stream. When an error is detected in the received speech frame, an error correction procedure is started. This error correction procedure usually includes a substitution procedure and muting procedure. In

25 the prior art, the speech parameters of the bad frame are replaced by attenuated or modified values from the previous good frame. However, some parameters (such as excitation in CELP parameters) in the corrupted frame may still be used for decoding.

 Figure 2 shows the principle of the prior-art method. As shown in Figure 2, a buffer labeled "parameter history" is used to store the speech parameters of the last good

30 frame. When a bad frame is detected, the Bad Frame Indicator (BFI) is set to 1 and the error concealment procedure is started. When the BFI is not set (BFI=0), the parameter history is updated and speech parameters are used for decoding without error

concealment. In the prior-art system, the error concealment procedure uses the parameter history for concealing the lost or erroneous parameters in the corrupted frames. Some speech parameters may be used from the received frame even though it is classified as a bad frame (BFI=1). For example, in a GSM Adaptive Multi-Rate (AMR) speech codec (ETSI specification 06.91), the excitation vector from the channel is always used. When the speech frames are totally lost frames (e.g., in some IP-based transmission systems), no parameters will be used from the received bad frame. In some cases, no frame will be received, or the frame will arrive so late that it has to be classified as a lost frame.

In a prior-art system, LTP-lag concealment uses the last good LTP-lag value with a slightly modified fractional part, and spectral parameters are replaced by the last good parameters slightly shifted towards constant mean. The gains (LTP and fixed codebook) may usually be replaced by the attenuated last good value or by the median of several last good values. The same substituted speech parameters are used for all sub-frames with slight modification to some of them.

The prior-art LTP concealment may be adequate for stationary speech signals, for example, voiced or stationary speech. However, for non-stationary speech signals, the prior-art method may cause unpleasant and audible artifacts. For example, when the speech signal is unvoiced or non-stationary, simply substituting the lag value in the bad frame with the last good lag value has the effect of generating a short voiced-speech segment in the middle of an unvoiced-speech burst (See Figure 10). The effect, as known as the "bing" artifact, can be annoying.

It is advantageous and desirable to provide a method and system for error concealment in speech decoding to improve the speech quality.

Summary of the Invention

The present invention takes advantage of the fact that there is a recognizable relationship among the long-term prediction (LTP) parameters in the speech signals. In particular, the LTP-lag has a strong correlation with the LTP-gain. When the LTP-gain is high and reasonably stable, the LTP-lag is typically very stable and the variation between adjacent lag values is small. In that case, the speech parameters are indicative of a voiced-speech sequence. When the LTP-gain is low or unstable, the LTP-lag is typically unvoiced, and the speech parameters are indicative of an unvoiced-speech sequence.

Once the speech sequence is classified as stationary (voiced) or non-stationary (unvoiced), the corrupted or bad frame in the sequence can be processed differently.

Accordingly, the first aspect of the present invention is a method for concealing errors in an encoded bit stream indicative of speech signals received in a speech decoder, wherein the encoded bit stream includes a plurality of speech frames arranged in speech sequences, and the speech frames include at least one corrupted frame preceded by one or more non-corrupted frames, wherein the corrupted frame includes a first long-term prediction lag value and a first long-term prediction gain value, and the non-corrupted frames include second long-term prediction lag values and second long-term prediction gain values, and wherein the second long-term prediction lag values include a last long-term prediction lag value, and the second long-term prediction gain values include a last long-term prediction gain value, and the speech sequences include stationary and non-stationary speech sequences, and wherein the corrupted frame can be partially corrupted or totally corrupted. The method comprises the steps of:

determining whether the first long-term prediction lag value is within or outside an upper limit and a lower limit determined based on the second long-term prediction lag values;

replacing the first long-term prediction lag value in the partially corrupted frame with a third lag value, when the first long-term prediction lag value is outside the upper and lower limits; and

retaining the first long-term prediction lag value in the partially corrupted frame when the first long-term prediction lag value is within the upper and lower limits.

Alternatively, the method comprises the steps of:

determining whether the speech sequence in which the corrupted frame is arranged is stationary or non-stationary, based on the second long-term prediction gain values;

when the speech sequence is stationary, replacing the first long-term prediction lag value in the corrupted frame with the last long-term prediction lag value; and

when the speech sequence is non-stationary, replacing the first long-term prediction lag value in the corrupted frame with a third long-term prediction lag value determined based on the second long-term prediction lag values and an adaptively-limited random lag jitter, and replacing the first long-term prediction gain value in the corrupted frame with a third long-term prediction gain value determined based on the second long-

term prediction gain values and an adaptively-limited random gain jitter.

Preferably, the third long-term prediction lag value is calculated based at least partially on a weighted median of the second long-term prediction lag values, and the adaptively-limited random lag jitter is a value bound by limits determined based on the
5 second long-term prediction lag values.

Preferably, the third long-term prediction gain value is calculated based at least partially on a weighted median of the second long-term prediction gain values, and the adaptively-limited random gain jitter is a value bound by limits determined based on the
10 second long-term prediction gain values.

Alternatively, the method comprises the steps of:

determining whether the corrupted frame is partially corrupted or totally corrupted;

replacing the first long-term prediction lag value in the corrupted frame with a third lag value if the corrupted frame is totally corrupted, wherein when the speech
15 sequence in which the totally corrupted frame is arranged is stationary, set the third lag value equal to the last long-term prediction lag value, and when said speech sequence is non-stationary, determining the third lag value based on the second long-term prediction values and an adaptively-limited random lag jitter; and

replacing the first long-term prediction lag value in the corrupted frame with a
20 fourth lag value if the corrupted frame is partially corrupted., wherein when the speech sequence in which the partially corrupted frame is arranged in stationary, set the fourth lag value equal to the last long-term prediction lag value, and when said speech sequence is non-stationary set the fourth lag value based on a decoded long-term prediction lag value searched from an adaptive codebook associated with the non-corrupted frame preceding
25 the corrupted frame, when said speech sequence is non-stationary.

The second aspect of the present invention is a speech signal transmitter and receiver system for encoding speech signals in an encoded bit stream and decoding the encoded bit stream into synthesized speech, wherein the encoded bit stream includes a plurality of speech frames arranged in speech sequences, and the speech frames include at
30 least one corrupted frame preceded by one or more non-corrupted frames, wherein the corrupted frame is indicated by a first signal and includes a first long-term prediction lag value and a first long-term prediction gain value, and the non-corrupted frames include

second long-term prediction lag values and second long-term prediction gain values, and wherein the second long-term prediction lag values include a last long-term prediction lag value, and the second long-term prediction gain values include a last long-term prediction gain value, and the speech sequences include stationary and non-stationary speech

5 sequences. The system comprises:

a first mechanism, responsive to the first signal, for determining whether the speech sequence in which the corrupted frame is arranged is stationary or non-stationary, based on the second long-term prediction gain values, and for providing a second signal indicative of whether the speech sequence is stationary or non-stationary; and

10 a second mechanism, responsive to the second signal, for replacing the first long-term prediction lag value in the corrupted frame with the last long-term prediction lag value when the speech sequence is stationary, and replacing the first long-term prediction lag value and the first long-term gain value in the corrupted frame with a third long-term prediction lag value and a third long-term prediction gain value, respectively, when the
15 speech sequence is non-stationary, wherein the third long-term prediction lag value is determined based on the second long-term prediction lag values and an adaptively-limited random lag jitter, and the third long-term prediction gain value is determined based on the second long-term prediction gain values and an adaptively-limited random gain jitter.

Preferably, the third long-term prediction lag value is calculated based at least
20 partially on a weighted median of the second long-term prediction lag values, and the adaptively-limited random lag jitter is a value bound by limits determined based on the second long-term prediction lag values.

Preferably, the third long-term prediction gain value is calculated based at least
25 partially on a weighted median of the second long-term prediction gain values, and the adaptively-limited random gain jitter is a value bound by limits determined based on the second long-term prediction gain values.

The third aspect of the present invention is a decoder for synthesizing speech from an encoded bit stream, wherein the encoded bit stream includes a plurality of speech frames arranged in speech sequences, and the speech frames include at least one corrupted
30 frame preceded by one or more non-corrupted frames, wherein the corrupted frame is indicated by a first signal and includes a first long-term prediction lag value and a first long-term prediction gain value, and the non-corrupted frames include second long-term

prediction lag values and second long-term prediction gain values, and wherein the second long-term prediction lag values include a last long-term prediction lag value and the second long-term prediction gain values include a last long-term prediction gain value and the speech sequences include stationary and non-stationary speech sequences. The decoder comprises:

a first mechanism, responsive to the first signal, for determining whether the speech sequence in which the corrupted frame is arranged is stationary or non-stationary, based on the second long-term prediction gain values, and for providing a second signal indicative of whether the speech sequence is stationary or non-stationary; and

a second mechanism, responsive to the second signal, for replacing the first long-term prediction lag value in the corrupted frame with the last long-term prediction lag value when the speech sequence is stationary, and replacing the first long-term prediction lag value and the first long-term gain value in the corrupted frame with a third long-term prediction lag value and a third long-term prediction gain value, respectively, when the speech sequence is non-stationary, wherein the third long-term prediction lag value is determined based on the second long-term prediction lag values and an adaptively-limited random lag jitter, and the third long-term prediction gain value is determined based on the second long-term prediction gain values and an adaptively-limited random gain jitter.

The fourth aspect of the present invention is a mobile station, which is arranged to receive an encoded bit stream containing speech data indicative of speech signals, wherein the encoded bit stream includes a plurality of speech frames arranged in speech sequences, and the speech frames include at least one corrupted frame preceded by one or more non-corrupted frames, wherein the corrupted frame is indicated by a first signal and includes a first long-term prediction lag value and a first long-term prediction gain value, and the non-corrupted frames include second long-term prediction lag values and second long-term prediction gain values, and wherein the second long-term prediction lag values include a last long-term prediction lag value and the second long-term prediction gain values include a last long-term prediction gain value and the speech sequences include stationary and non-stationary speech sequences. The mobile station comprises:

a first mechanism, responsive to the first signal, for determining whether the speech sequence in which the corrupted frame is arranged is stationary or non-stationary, based on the second long-term prediction gain values, and for providing a second signal

indicative of whether the speech sequence is stationary or non-stationary; and

a second mechanism, responsive to the second signal, for replacing the first long-term prediction lag value in the corrupted frame with the last long-term prediction lag value when the speech sequence is stationary, and replacing the first long-term prediction lag value and the first long-term gain value in the corrupted frame with a third long-term prediction lag value and a third long-term prediction gain value, respectively, when the speech sequence is non-stationary, wherein the third long-term prediction lag value is determined based on the second long-term prediction lag values and an adaptively-limited random lag jitter, and the third long-term prediction gain value is determined based on the second long-term prediction gain values and an adaptively-limited random gain jitter.

The fifth aspect of the present invention is an element in a telecommunication network, which is arranged to receive an encoded bit stream containing speech data from a mobile station, wherein the speech data includes a plurality of speech frames arranged in speech sequences, and the speech frames include at least one corrupted frame preceded by one or more non-corrupted frames, wherein the corrupted frame is indicated by a first signal and includes a first long-term prediction lag value and a first long-term prediction gain value, and the non-corrupted frames include second long-term prediction lag values and second long-term prediction gain values, and wherein the second long-term prediction lag values include a last long-term prediction lag value and the second long-term prediction gain values include a last long-term prediction gain value and the speech sequences include stationary and non-stationary speech sequences. The element comprises:

a first mechanism, responsive to the first signal, for determining whether the speech sequence in which the corrupted frame is arranged is stationary or non-stationary, based on the second long-term prediction gain values, and for providing a second signal indicative of whether the speech sequence is stationary or non-stationary; and

a second mechanism, responsive to the second signal, for replacing the first long-term prediction lag value in the corrupted frame with the last long-term prediction lag value when the speech sequence is stationary, and replacing the first long-term prediction lag value and the first long-term gain value in the corrupted frame with a third long-term prediction lag value and a third long-term prediction gain value, respectively, when the speech sequence is non-stationary, wherein the third long-term prediction lag value is

determined based on the second long-term prediction lag values and an adaptively-limited random lag jitter, and the third long-term prediction gain value is determined based on the second long-term prediction gain values and an adaptively-limited random gain jitter.

The present invention will become apparent upon reading the description taken in conjunction with Figures 3 to 11c.

Brief Description of the Drawings

Figure 1 is a block diagram illustrating a generic distributed speech codec, wherein the encoded bit stream containing speech data is conveyed from an encoder to a decoder via a communication channel or a storage medium.

Figure 2 is a block diagram illustrating a prior-art error concealment apparatus in a receiver.

Figure 3 is a block diagram illustrating the error concealment apparatus in a receiver, according to the present invention.

Figure 4 is a flow chart illustrating the method of error concealment according to the present invention.

Figure 5 is a diagrammatic representation of a mobile station, which includes an error concealment module, according to the present invention.

Figure 6 is a diagrammatic representation of a telecommunication network using a decoder, according to the present invention.

Figure 7 is a plot of LTP-parameters illustrating the lag and gain profiles in a voiced speech sequence.

Figure 8 is a plot of LTP-parameters illustrating the lag and gain profiles in an unvoiced speech sequence.

Figure 9 is a plot of LTP-lag values in a series of sub-frames illustrating the difference between the prior-art error concealment approach and the approach according to the present invention.

Figure 10 is another plot of LTP-lag values in a series of sub-frames illustrating the difference between the prior-art error concealment approach and the approach according to the present invention.

Figure 11a is a plot of speech signals illustrating an error-free speech sequence having the location of the bad frame of the speech channel, as shown in Figures 11b and

11c.

Figure 11b is a plot of speech signals illustrating the concealment of parameters in a bad frame according to the prior art approach.

Figure 11c is a plot of speech signals illustrating the concealment of parameters in a bad frame according to the present invention.

Best Mode for Carrying Out the Invention

Figure 3 illustrates a decoder **10**, which includes a decoding module **20** and an error concealment module **30**. The decoding module **20** receives a signal **140**, which is normally indicative of speech parameters **102** for speech synthesis. The decoding module **20** is known in the art. The error concealment module **30** is arranged to receive an encoded bit stream **100**, which includes a plurality of speech streams arranged in speech sequences. A bad-frame detection device **32** is used to detect corrupted frames in the speech sequences and provide a Bad-Frame-Indicator (BFI) signal **110** representing a BFI flag when a corrupted frame is detected. BFI is also known in the art. The BFI signal **110** is used to control two switches **40** and **42**. Normally, the speech frames are not corrupted and the BFI flag is 0. The terminal **S** is operatively connected to the terminal **0** in the switches **40** and **42**. The speech parameters **102** are conveyed to a buffer, or "parameter history" storage, **50** and the decoding module **20** for speech synthesis. When a bad frame is detected by the bad-frame detection device **32**, the BFI flag is set to 1. The terminal **S** is connected to the terminal **1** in the switches **40** and **42**. Accordingly, the speech parameters **102** are provided to an analyzer **70**, and the speech parameters needed for speech synthesis are provided by a parameter concealment module **60** to the decoding module **20**. The speech parameters **102** typically include LPC parameters for short term prediction, excitation parameters, a long-term prediction (LTP) lag parameter, an LTP gain parameter and other gain parameters. The parameter history storage **50** is used to store the LTP-lag and LTP-gain of a number of non-corrupted speech frames. The contents of the parameter history storage **50** are constantly updated so that the last LTP-gain parameter and the last LTP-lag parameter stored in the storage **50** are those of the last non-corrupted speech frame. When a corrupted frame in a speech sequence is received in the decoder **10**, the BFI flag is set to 1 and the speech parameters **102** of the corrupted frame are conveyed to the analyzer **70** through the switch **40**. By comparing the LTP-gain

parameter in the corrupted frame and the LTP-gain parameters stored in the storage 50, it is possible for the analyzer 70 to determine whether the speech sequence is stationary or non-stationary, based on the magnitude and its variation in the LTP-gain parameters in neighboring frames. Typically, in a stationary sequence, the LTP-gain parameters are high and reasonably stable, the LTP-lag value is stable and the variation in adjacent LTP-lag values is small, as shown in Figure 7. In contrast, in a non-stationary sequence, the LTP-gain parameters are low and unstable, and the LTP-lag is also unstable, as shown in Figure 8. The LTP-lag values are changing more or less randomly. Figure 7 shows the speech sequence for the word “*viiniä*”. Figure 8 shows the speech sequence for the word “*exhibition*”.

If the speech sequence that includes the corrupted frame is voiced or stationary, the last good LTP-lag is retrieved from the storage 50 and conveyed to the parameter concealment module 60. The retrieved good LTP-lag is used to replace the LTP-lag of the corrupted frame. Because the LTP-lag in a stationary speech sequence is stable and its variation is small, it is reasonable to use a previous LTP-lag with small modification to conceal the corresponding parameter in corrupted frame. Subsequently, an RX signal 104 causes the replacement parameters, as denoted by reference numeral 134, to be conveyed to the decoding module 20 through the switch 42.

If the speech sequence that includes the corrupted frame is unvoiced or non-stationary, the analyzer 70 calculates a replacement LTP-lag value and a replacement LTP-gain value for parameter concealment. Because LTP-lag in a non-stationary speech sequence is unstable and its variation in adjacent frames is typically very large, parameter concealment should allow the LTP-lag in an error-concealed non-stationary sequence to fluctuate in a random fashion. If the parameters in the corrupted frame are totally corrupted, such as in a lost frame, the replacement LTP-lag is calculated by using a weighted median of the previous good LTP-lag values along with an adaptively-limited random jitter. The adaptively-limited random jitter is allowed to vary within limits calculated from the history of the LTP values, so that the parameter fluctuation in an error-concealed segment is similar to the previous good section of the same speech sequence.

An exemplary rule for LTP-lag concealment is governed by a set of conditions as follows:

If

$minGain > 0.5$ AND $LagDif < 10$; OR
 $lastGain > 0.5$ AND $secondLastGain > 0.5$,

5 then the last received good LTP-lag is used for the totally corrupted frame. Otherwise, $Update_lag$, a weighted average of the LTP-lag buffer with randomization, is used for the totally corrupted frame. $Update_lag$ is calculated in a manner as described below:

The LTP-lag buffer is sorted and the three biggest buffer values are retrieved. The
 10 average of these three biggest values is referred to as the weighted average lag (WAL), and the difference from these biggest values is referred to as the weighted lag difference (WLD).

Let $RAND$ be the randomization with the scale of $(-WLD/2, WLD/2)$, then

$Update_lag = WAL + RAND(-WLD/2, WLD/2)$,

15

wherein

$minGain$ is the smallest value of the LTP-gain buffer;

$LagDif$ is the difference between the smallest and the largest LTP-lag values;

$lastGain$ is the last received good LTP-gain; and

20

$secondLastGain$ is the second last received good LTP-gain.

If the parameters in the corrupted frame are partially corrupted, then the LTP-lag value in the corrupted frame is replaced accordingly. That the frame is partially corrupted is determined by a set of exemplary LTP-feature criteria given below:

25

If

(1) $LagDif < 10$ AND $(minLag - 5) < T_{bf} < (maxLag + 5)$; OR

(2) $lastGain > 0.5$ AND $secondLastGain > 0.5$ AND $(lastLag - 10) < T_{bf} < (lastLag + 10)$; OR

30

(3) $minGain < 0.4$ AND $lastGain = minGain$ AND $minLag < T_{bf} < maxLag$; OR

(4) $LagDif < 70$ AND $minLag < T_{bf} < maxLag$; OR

(5) $meanLag < T_{bf} < maxLag$

is true, then T_{bf} is used to replace the LTP-lag in the corrupted frame. Otherwise, the corrupted frame is treated as a totally corrupted frame, as described above. In the above conditions:

$maxLag$ is the largest value of the LTP-lag buffer;

5 $meanLag$ is the average of the LTP-lag buffer;

$minLag$ is the smallest value of the LTP-lag buffer;

$lastLag$ is the last received good LTP-lag value; and

T_{bf} is a decoded LTP lag which is searched, when the BFI is set, from the adaptive codebook as if the BFI is not set.

10

Two examples of parameter concealment are shown in Figures 9 and 10. As shown, the profile of the replacement LTP-lag values in the bad frame, according to the prior art, is rather flat, but the profile of the replacement, according to the present invention, allows some fluctuation, similar to the error-free profile. The difference
15 between the prior art approach and the present invention is further illustrated in Figures 11b and 11c, respectively, based on the speech signals in an error-free channel, as shown in Figure 11a.

When the parameters in the corrupted frame are partially corrupted, the parameter concealment can be further optimized. In partially corrupted frames, the LTP-lags in the
20 corrupted frames may still yield an acceptable synthesized speech segment. Accordingly to the GSM specifications, the BFI flag is set by a Cyclic Redundancy Check (CRC) mechanism or other error detection mechanisms. These error detection mechanisms detect errors in the most significant bits in the channel decoding process. Accordingly, even when only a few bits are erroneous, the error can be detected and the BFI flag is set
25 accordingly. In the prior-art parameter concealment approach, the entire frame is discarded. As a result, information contained in the correct bits is thrown away.

Typically, in the channel decoding process, the BER per frame is a good indicator for the channel condition. When the channel condition is good, the BER per frame is small and a high percentage of the LTP-lag values in the erroneous frames are correct.
30 For example, when the frame error rate (FER) is 0.2%, over 70% of the LTP-lag values are correct. Even when the FER reaches 3%, about 60% of the LTP-lag values are still correct. The CRC can accurately detect a bad frame and set the BFI flag accordingly.

However, the CRC does not provide an estimation of the BER in the frame. If the BFI flag is used as the only criterion for parameter concealment, then a high percentage of the correct LTP-lag values could be wasted. In order to prevent a large amount of correct LTP-lags from being thrown away, it is possible to adapt a decision criterion for parameter concealment based on the LTP history. It is also possible to use the FER, for example, as the decision criterion. If the LTP-lag meets the decision criterion, no parameter concealment is necessary. In that case, the analyzer 70 conveys the speech parameters 102, as received through the switch 40, to the parameter concealment module 60 which then conveys the same to the decoding module 20 through the switch 42. If the LTP-lag does not meet that decision criterion, then the corrupted frame is further examined using the LTP-feature criteria, as described hereinabove, for parameter concealment.

In stationary speech sequences, the LTP-lag is very stable. Whether most of the LTP-lag values in a corrupted frame are correct or erroneous can be correctly predicted with high probability. Thus, it is possible to adapt a very strict criterion for parameter concealment. In non-stationary speech sequences, it may be difficult to predict whether the LTP-lag value in a corrupted frame is correct, because of the unstable nature of the LTP parameters. However, that the prediction is correct or wrong is less important in non-stationary speech than in stationary speech. While allowing erroneous LTP-lag values to be used in decoding stationary speech may cause the synthesized speech to be unrecognizable, allowing erroneous LTP-lag values to be used in decoding non-stationary speech usually only increases the audible artifacts. Thus, the decision criterion for parameter concealment in non-stationary speech can be relatively lax.

As mentioned earlier, the LTP-gain fluctuates greatly in non-stationary speech. If the same LTP-gain value from the last good frame is used repeatedly to replace the LTP-gain value of one or more corrupted frames in a speech sequence, the LTP-gain profile in the gain concealed segment will be flat (similar to the prior-art LTP-lag replacement, as shown in Figures 7 and 8), in stark contrast to the fluctuating profile of the non-corrupted frames. The sudden change in the LTP-gain profile may cause unpleasant audible artifacts. In order to minimize these audible artifacts, it is possible to allow the replacement LTP-gain value to fluctuate in the error-concealed segment. For this purpose, the analyzer 70 can be also used to determine the limits between which the

replacement LTP-gain value is allowed to fluctuate based on the gain values in the LTP history.

LTP-gain concealment can be carried out in a manner as described below. When the BFI is set, a replacement LTP-gain value is calculated according to a set of LTP-gain concealment rules. The replacement LTP-gain is denoted as *Updated_gain*.

- (1) If $gainDif > 0.5$ AND $lastGain = maxGain > 0.9$ AND $subBF=1$, then
 $Updated_gain = (secondLastGain + thirdLastGain)/2$;
- (2) If $gainDif > 0.5$ AND $lastGain = maxGain > 0.9$ AND $subBF=2$, then
 $Updated_gain = meanGain + randVar * (maxGain - meanGain)$;
- (3) If $gainDif > 0.5$ AND $lastGain = maxGain > 0.9$ AND $subBF=3$, then
 $Updated_gain = meanGain - randVar * (meanGain - minGain)$;
- (4) If $gainDif > 0.5$ AND $lastGain = maxGain > 0.9$ AND $subBF=4$, then
 $Updated_gain = meanGain + randVar * (maxGain - meanGain)$;

15

In the previous conditions, *Updated_gain* cannot be larger than *lastGain*. If the previous conditions cannot be met, the following conditions are used:

- (5) If $gainDif > 0.5$, then
 $Updated_gain = lastGain$;
- (6) If $gainDif < 0.5$ AND $lastGain = maxGain$, then
 $Updated_gain = meanGain$;
- (7) If $gainDIF < 0.5$, then
 $Updated_gain = lastGain$,

25 Wherein

meanGain is the average of the LTP-gain buffer;

maxGain is the largest value of the LTP-gain buffer;

minGain is the smallest value of the LTP-gain buffer;

randVar is a random value between 0 and 1,

30 *gainDIF* is the difference between the smallest and the largest LTP-gain values in the LTP-gain buffer;

lastGain is the last received good LTP-gain;

seconLastGain is the second last received good LTP-gain;
thirdLastGain is the third last received good LTP-gain; and
subBF is the order of the subframe.

5 Figure 4 illustrates the method of error-concealment, according to the present invention. As the encoded bit stream is received at step **160**, the frame is checked to see if it is corrupted at step **162**. If the frame is not corrupted, then the parameter history of the speech sequence is updated at step **164**, and the speech parameters of the current frame are decoded at step **166**. The procedure then goes back to step **162**. If the frame is
10 bad or corrupted, the parameters are retrieved from the parameter history storage at step **170**. Whether the corrupted frame is part of the stationary speech sequence or non-stationary speech sequence is determined at step **172**. If the speech sequence is stationary, the LTP-lag of the last good frame is used to replace the LTP-lag in the corrupted frame at step **174**. If the speech sequence is non-stationary, a new lag value and new gain value
15 are calculated based on the LTP history at step **180**, and they are used to replace the corresponding parameters in the corrupted frame at step **182**.

 Figure 5 shows a block diagram of a mobile station **200** according to one exemplary embodiment of the invention. The mobile station comprises parts typical of the device, such as a microphone **201**, keypad **207**, display **206**, earphone **214**,
20 transmit/receive switch **208**, antenna **209** and control unit **205**. In addition, the figure shows transmitter and receiver blocks **204**, **211** typical of a mobile station. The transmitter block **204** comprises a coder **221** for coding the speech signal. The transmitter block **204** also comprises operations required for channel coding, deciphering and modulation as well as RF functions, which have not been drawn in Figure 5 for clarity.
25 The receiver block **211** also comprises a decoding block **220** according to the invention. Decoding block **220** comprises an error concealment module **222** like the parameter concealment module **30** shown in Figure 3. The signal coming from the microphone **201**, amplified at the amplification stage **202** and digitized in the A/D converter, is taken to the transmitter block **204**, typically to the speech coding device comprised by the transmit
30 block. The transmission signal, which is processed, modulated and amplified by the transmit block, is taken via the transmit/receive switch **208** to the antenna **209**. The signal to be received is taken from the antenna via the transmit/receive switch **208** to the receiver

block 211, which demodulates the received signal and decodes the deciphering and the channel coding. The resulting speech signal is taken via the D/A converter 212 to an amplifier 213 and further to an earphone 214. The control unit 205 controls the operation of the mobile station 200, reads the control commands given by the user from the keypad
5 207 and gives messages to the user by means of the display 206.

The parameter concealment module 30, according to the invention, can also be used in a telecommunication network 300, such as an ordinary telephone network, or a mobile station network, such as the GSM network. Figure 6 shows an example of a block diagram of such a telecommunication network. For example, the telecommunication
10 network 300 can comprise telephone exchanges or corresponding switching systems 360, to which ordinary telephones 370, base stations 340, base station controllers 350 and other central devices 355 of telecommunication networks are coupled. Mobile stations 330 can establish connection to the telecommunication network via the base stations 340. A decoding block 320, which includes an error concealment module 322 similar to the error
15 concealment module 30 shown in Figure 3, can be particularly advantageously placed in the base station 340, for example. However, the decoding block 320 can also be placed in the base station controller 350 or other central or switching device 355, for example. If the mobile station system uses separate transcoders, for example, between the base stations and the base station controllers, for transforming the coded signal taken over the
20 radio channel into a typical 64 kbit/s signal transferred in a telecommunication system and vice versa, the decoding block 320 can also be placed in such a transcoder. In general, the decoding block 320, including the parameter concealment module 322, can be placed in any element of the telecommunication network 300, which transforms the coded data stream into an uncoded data stream. The decoding block 320 decodes and filters the
25 coded speech signal coming from the mobile station 330, whereafter the speech signal can be transferred in the usual manner as uncompressed forward in the telecommunication network 300.

It should be noted that the error concealment method of the present invention has been described with respect to stationary and non-stationary speech sequences, and that
30 stationary speech sequences are usually voiced and non-stationary speech sequences are usually unvoiced. Thus, it will be understood that the disclosed method is applicable to error concealment in voiced and unvoiced speech sequences.

The present invention is applicable to CELP type speech codecs and can be adapted to other types of speech codecs as well. Thus, although the invention has been described with respect to a preferred embodiment thereof, it will be understood by those skilled in the art that the foregoing and various other changes, omissions and deviations in the form and detail thereof may be made without departing from the spirit and scope of this invention.

What is claimed is:

1. A method for concealing errors in an encoded bit stream indicative of speech signals received in a speech decoder, wherein the encoded bit stream includes a plurality of speech frames arranged in speech sequences, and the speech frames include at least one partially corrupted frame preceded by one or more non-corrupted frames, wherein the partially corrupted frame includes a first long-term prediction lag value and a first long-term prediction gain value, and the non-corrupted frames include second long-term prediction lag values and second long-term prediction gain values, and wherein the second long-term prediction lag values include a last long-term prediction lag value, and the second long-term prediction gain values include a last long-term prediction gain value, said method comprising the steps of:
 - providing an upper limit and a lower limit based on the second long-term prediction lag values;
 - determining whether the first long-term prediction lag value is within or outside the upper and lower limits;
 - replacing the first long-term prediction lag value in the partially corrupted frame with a third lag value, when the first long-term prediction lag value is outside the upper and lower limits; and
 - retaining the first long-term prediction lag value in the partially corrupted frame when the first long-term prediction lag value is within the upper and lower limits.
2. The method of claim 1, further comprising the step of replacing the first long-term prediction gain value in the partially corrupted frame with a third gain value, when the first long-term lag value is outside the upper and lower limits.
3. The method of claim 1, wherein the third lag value is calculated based the second long-term prediction lag values and an adaptively-limited random lag jitter bound by further limits determined based on the second long-term prediction lag values.
4. The method of claim 2, wherein the third gain value is calculated based on of the second long-term prediction gain values and an adaptively-limited random gain jitter bound by limits determined based on the second long-term prediction gain values.

5. A method for concealing errors in an encoded bit stream indicative of speech signals received in a speech decoder, wherein the encoded bit stream includes a plurality of speech frames arranged in speech sequences, and the speech frames include at least one corrupted frame preceded by one or more non-corrupted frames, wherein the corrupted frame includes a first long-term prediction lag value and a first long-term prediction gain value, and the non-corrupted frames include second long-term prediction lag values and second long-term prediction gain values, and wherein the second long-term prediction lag values include a last long-term prediction lag value, and the second long-term prediction gain values include a last long-term prediction gain value and the speech sequences include stationary and non-stationary speech sequences, and wherein the corrupted frame can be a totally corrupted frame or a partially corrupted frame, said method comprising the steps of:

determining whether the corrupted frame is partially corrupted or totally corrupted;

replacing the first long-term prediction lag value in the corrupted frame with a third lag value if the corrupted frame is totally corrupted; and

replacing the first long-term prediction lag value in the corrupted frame with a fourth lag value if the corrupted frame is partially corrupted.

20

6. The method of claim 5, further comprising the steps of:

determining whether the speech sequence in which the partially corrupted frame is arranged is stationary or non-stationary;

setting the fourth lag value equal to the last long-term prediction lag value, when said speech sequence is stationary ; and

25

determining the fourth lag value based on a decoded long-term prediction lag value searched from an adaptive codebook associated with the non-corrupted frame preceding the corrupted frame, when said speech sequence is non-stationary.

7. The method of claim 5, further comprising the steps of:

determining whether the speech sequence in which the totally corrupted frame is arranged is stationary or non-stationary;

30

setting the third lag value equal to the last long-term prediction lag value, when said speech sequence is stationary; and

determining the third lag value based on the second long-term prediction values and an adaptively-limited random lag jitter, when said speech sequence is non-stationary.

5

8. The method of claim 6, wherein the second long-term prediction lag values further include a second last long-term prediction lag value and a third last long-term prediction lag value, and the second long-term prediction gain values further include a second last long-term prediction gain value and a third last long-term prediction gain value, said
10 method further comprising the steps of:

determining minLag, which is the smallest lag value among the second long-term prediction lag values;

determining maxLag, which is the largest lag value among the second long-term prediction lag values;

15 determining meanLag, which is an average of the second long-term prediction lag values;

determining difLag, which is the difference of maxLag and minLag;

determining minGain, which is the smallest gain value among the second long-term prediction gain values;

20 determining maxGain, which is the largest gain value among the second long-term prediction gain values; and

determining meanGain, which is an average of the second long term gain values; wherein

if $\text{difLag} < 10$, and $(\text{minLag} - 5) < \text{the fourth lag value} < (\text{maxLag} + 5)$; or

25 if the last long-term prediction gain value is larger than 0.5, and the second last long-term prediction gain value is larger than 0.5, and the fourth lag value is smaller than a sum of the last long-term prediction value and 10, and a sum of the fourth lag value and 10 is larger than the last long-term prediction value; or

30 if $\text{minGain} < 0.4$, and the last long-term prediction gain value is equal to minGain, and the fourth lag value is larger than minLag but smaller than maxLag; or

if $\text{difLag} < 70$, and the fourth lag value is larger than minLag but smaller than maxLag; or

if the fourth lag value is larger than meanLag but smaller than maxLag; then the corrupted frame is determined as partially corrupted.

9. The method of claim 6, wherein when said speech sequence is non-stationary, said method further comprising the step of determining a frame-error rate of the speech frames such that

if the frame-error rate reaches a determined value, the fourth lag value is determined based on said decoded long-term prediction lag value, and

if the frame-error rate is smaller than the determined value, the fourth lag value is set equal to the last long-term prediction lag value.

10. The method of claim 5, wherein the stationary speech sequences include voiced sequences, and the non-stationary speech sequences include unvoiced sequences.

11. A speech signal transmitter and receiver system for encoding speech signals in an encoded bit stream and decoding the encoded bit stream into synthesized speech, wherein the encoded bit stream includes a plurality of speech frames arranged in speech sequences, and the speech frames include at least one corrupted frame preceded by one or more non-corrupted frames, wherein the corrupted frame includes a first long-term prediction lag value and a first long-term prediction gain value, and the non-corrupted frames include second long-term prediction lag values and second long-term prediction gain values, and wherein the second long-term prediction lag values include a last long-term prediction lag value and the second long-term prediction gain values include a last long-term prediction gain value, and the speech sequences include stationary and non-stationary speech sequences, and a first signal is used to indicate the corrupted frame, said system comprising:

a first means, responsive to the first signal, for determining whether the speech sequence in which the corrupted frame is arranged is stationary or non-stationary, and for providing a second signal indicative of said determining;

a second means, responsive to the second signal, for replacing the first long-term prediction lag value in the corrupted frame with the last long-term prediction lag value when said speech sequence is stationary, and replacing the first long-term prediction lag

value in the corrupted frame with a third lag value when said speech sequence is non-stationary.

12. The system of claim 11, wherein the third lag value is determined based on the second long-term prediction lag values and an adaptively-limited random lag jitter.

13. The system of claim 11, wherein the second means further replaces the first long-term prediction gain value in the corrupted frame with a third gain value when said speech sequence is non-stationary.

14. The system of claim 13, wherein the third gain value is determined based on the second long-term prediction gain values and an adaptively-limited random gain jitter.

15. The system of claim 11, wherein the stationary speech sequences include voiced sequences, and the non-stationary speech sequences include unvoiced sequences.

16. A decoder for synthesizing speech from an encoded bit stream, wherein the encoded bit stream includes a plurality of speech frames arranged in speech sequences, and the speech frames include at least one corrupted frame preceded by one or more non-corrupted frames, wherein the corrupted frame includes a first long-term prediction lag value and a first long-term prediction gain value, and the non-corrupted frames include second long-term prediction lag values and second long-term prediction gain values, and wherein the second long-term prediction lag values include a last long-term prediction lag value and the second long-term prediction gain values include a last long-term prediction gain value and the speech sequences include stationary and non-stationary speech sequences, and a first signal is used to indicate the corrupted frame, said decoder comprising:

a first means, responsive to the first signal, for determining whether the speech sequence in which the corrupted frame is arranged is stationary or non-stationary, and for providing a second signal indicative of said determining;

a second means, responsive to the second signal, for replacing the first long-term prediction lag value in the corrupted frame with the last long-term prediction lag value when said speech sequence is stationary, and replacing the first long-term prediction lag

value in the corrupted frame with a third lag value when said speech sequence is non-stationary.

17. The decoder of claim 16, wherein the lag value is determined based on the second long-term prediction lag values and an adaptively-limited random lag jitter.

18. The decoder of claim 16, wherein the second means further replaces the first long-term gain value in the corrupted frame with a third gain value when said speech sequence is non-stationary.

19. The decoder of claim 18, wherein the third gain value is determined based on the second long-term prediction gain values and an adaptively-limited random gain jitter.

20. The decoder of claim 16, wherein the stationary speech sequences include voiced sequences, and the non-stationary speech sequences include unvoiced sequences.

21. A mobile station, which is arranged to receive an encoded bit stream containing speech data indicative of speech signals, wherein the encoded bit stream includes a plurality of speech frames arranged in speech sequences, and the speech frames include at least one corrupted frame preceded by one or more non-corrupted frames, wherein the corrupted frame includes a first long-term prediction lag value and a first long-term prediction gain value, and the non-corrupted frames include second long-term prediction lag values and second long-term prediction gain values, and wherein the second long-term prediction lag values include a last long-term prediction lag value and the second long-term prediction gain values include a last long-term prediction gain value and the speech sequences include stationary and non-stationary speech sequences, and wherein a first signal is used to indicate the corrupted frame, said mobile station comprising:

a first means, responsive to the first signal, for determining whether the speech sequence in which the corrupted frame is arranged is stationary or non-stationary, and for providing a second signal indicative of said determining; and

a second means, responsive to the second signal, for replacing the first long-term prediction lag value in the corrupted frame with the last long-term prediction lag value

when said speech sequence is stationary, and replacing the first long-term prediction lag value in the corrupted frame with a third lag value when said speech sequence is non-stationary.

5 22. The mobile station of claim 21, wherein the third lag value is determined based on the second long-term prediction lag values and an adaptively-limited random lag jitter.

23. The mobile station of claim 21, wherein the second means further replaces the first long-term gain value in the corrupted frame with a third gain value when said speech
10 sequence is non-stationary.

24. The mobile station of claim 23, wherein the third gain value is determined based on the second long-term prediction gain values and an adaptively-limited random gain jitter.

15

25. The mobile station of claim 21, wherein the stationary speech sequences include voiced sequences, and the non-stationary speech sequences include unvoiced sequences.

26. An element in a telecommunication network, which is arranged to receive an
20 encoded bit stream containing speech data from a mobile station, wherein the speech data includes a plurality of speech frames arranged in speech sequences, and the speech frames include at least one corrupted frame preceded by one or more non-corrupted frames, wherein the corrupted frame includes a first long-term prediction lag value and a first
long-term prediction gain value, and the non-corrupted frames include second long-term
25 prediction lag values and second long-term prediction gain values, and wherein the second long-term prediction lag values include a last long-term prediction lag value and the second long-term prediction gain values include a last long-term prediction gain value and the speech sequences include stationary and non-stationary speech sequences, and wherein a first signal is used to indicate the corrupted frame, said element comprising:

30 a first means, responsive to the first signal, for determining whether the speech sequence in which the corrupted frame is arranged is stationary or non-stationary, and for providing a second signal indicative of said determining; and

a second means, responsive to the second signal, for replacing the first long-term prediction lag value in the corrupted frame with the last long-term prediction lag value when said speech sequence is stationary, and replacing the first long-term prediction lag value in the corrupted frame with a third lag value when said speech sequence is non-stationary.

27. The element of claim 26, wherein the third long-term prediction lag value is determined based on the second long-term prediction lag values and an adaptively-limited random lag jitter.

28. The element of claim 26, wherein the third means further replaces the first long-term prediction gain value with a third gain value when said speech sequence is non-stationary.

29. The element of claim 28, wherein the third gain value is determined based on the second long-term prediction gain values and an adaptively-limited random gain jitter.

30. The element of claim 26, wherein the stationary speech sequences include voiced sequences, and the non-stationary speech sequences include unvoiced sequences.

31. (New) The method of claim 5, wherein the second long-term prediction gain values further include a second last long-term prediction gain value, and

if $difLag < 10$, and $(minLag - 5) < decodedLag < (maxLag + 5)$; or

if $lastGain > 0.5$, and $secondlastGain > 0.5$, and

$(lastLag - 10) < decodedLag < (lastLag + 10)$; or

if $minGain < 0.4$, and $lastGain > 0.5$, and $minLag < decodedLag < maxLag$; or

if $difLag < 70$, and $minLag < decodedLag < maxLag$; or

if $meanLag < decodedLag < maxLag$,

then the fourth value is set equal to the *decodedLag*, wherein

$minLag$ is a smallest lag value among the second long-term prediction lag values,
 $maxLag$ is a largest lag value among the second long-term prediction lag values,
 $meanLag$ is an average of the second long-term prediction lag values,
 $difLag$ is a difference of $maxLag$ and $minLag$,
5 $minGain$ is a smallest gain value among the second long-term prediction gain values,
 $meanGain$ an average of the second long-term prediction gain values,
 $lastGain$ is the last long-term prediction gain value,
 $lastLag$ is the last long-term prediction lag value,
10 $secondlastGain$ is the second last long-term prediction lag value, and
 $decodedLag$ is a decoded long-term prediction lag which is searched from an adaptive codebook associated with the non-corrupted frame preceding the corrupted frame.

15 32. (New) The method of claim 8, wherein the first long-term prediction gain value is replaced by $Updated_gain$, and wherein

If $gainDif > 0.5$ AND $lastGain = maxGain > 0.9$ AND $subBF=1$, then

$$Updated_gain = (secondLastGain + thirdLastGain)/2;$$

20 If $gainDif > 0.5$ AND $lastGain = maxGain > 0.9$ AND $subBF=2$, then

$$Updated_gain = meanGain + randVar * (maxGain - meanGain);$$

If $gainDif > 0.5$ AND $lastGain = maxGain > 0.9$ AND $subBF=3$, then

$$Updated_gain = meanGain - randVar * (meanGain - minGain);$$

If $gainDif > 0.5$ AND $lastGain = maxGain > 0.9$ AND $subBF=4$, then

25 $Updated_gain = meanGain + randVar * (maxGain - meanGain);$

and when $Updated_gain$ is equal to or smaller than $lastGain$;

or

30 If $gainDif > 0.5$, then

$$Updated_gain = lastGain;$$

(8) If $gainDif < 0.5$ AND $lastGain = maxGain$, then

$Updated_gain = meanGain;$

(9) If $gainDIF < 0.5$, then

$Updated_gain = lastGain,$

and when $Updated_gain$ is larger than $lastGain$,

5

wherein

$randVar$ is a random value between 0 and 1,

$gainDIF$ is the difference between a smallest and a largest long-term prediction gain value;

10 $lastGain$ is the last long-term prediction gain value;

$secondLastGain$ is the second last long-term prediction gain value;

$thirdLastGain$ is the third last long-term prediction gain value; and

$subBF$ is an order of the subframe.

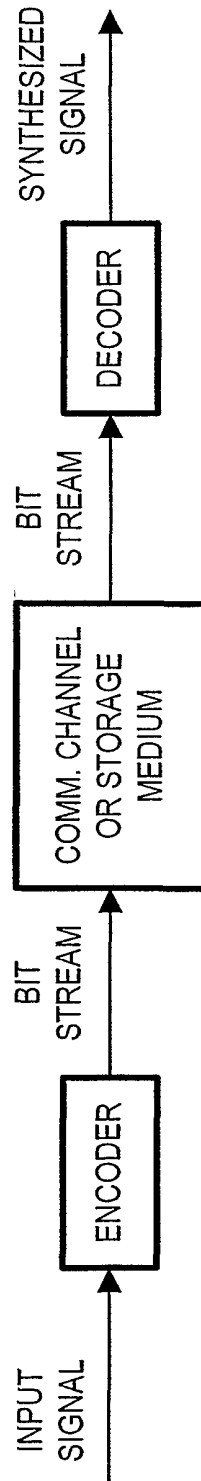

FIG. 1

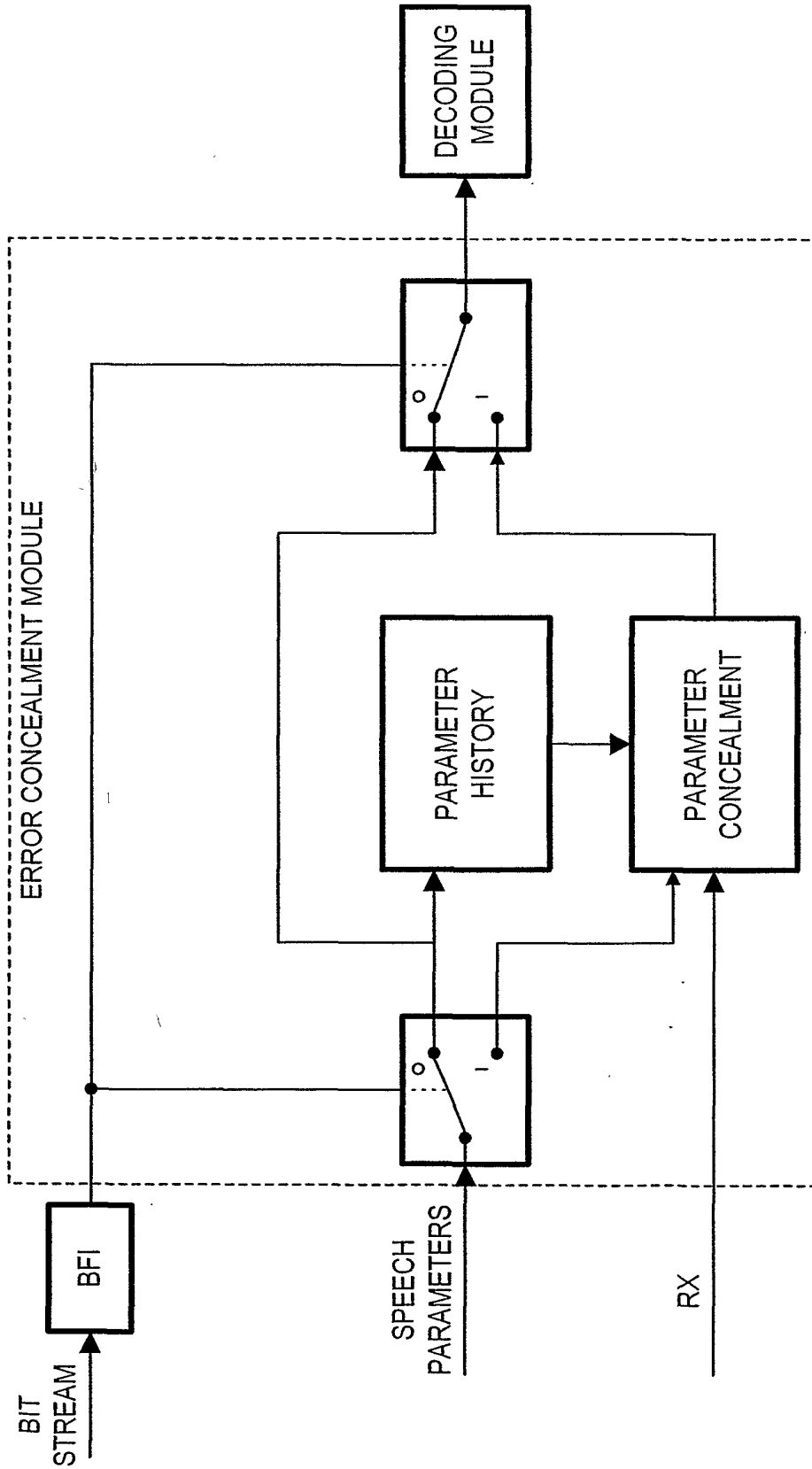

FIG. 2

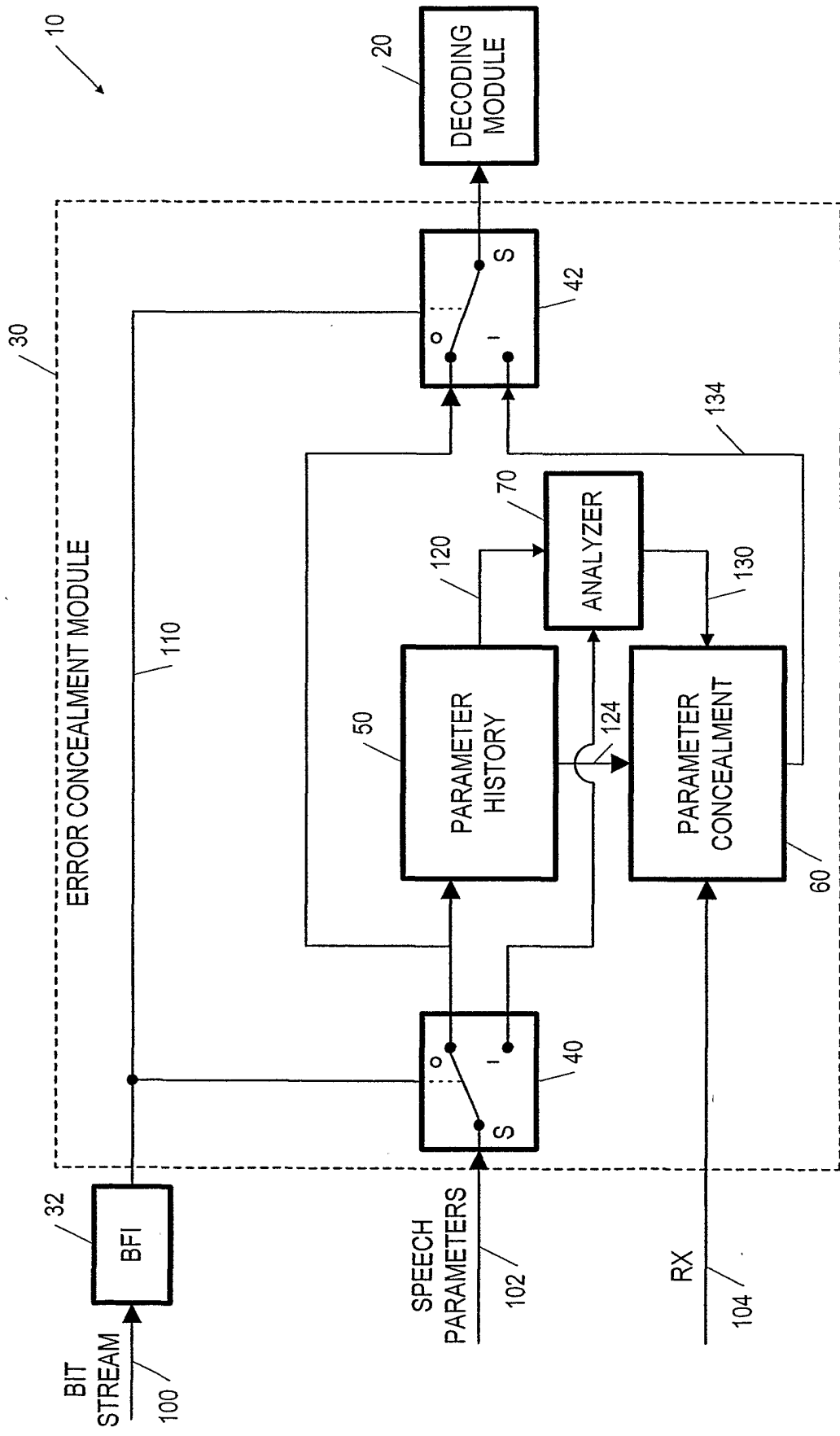

FIG. 3

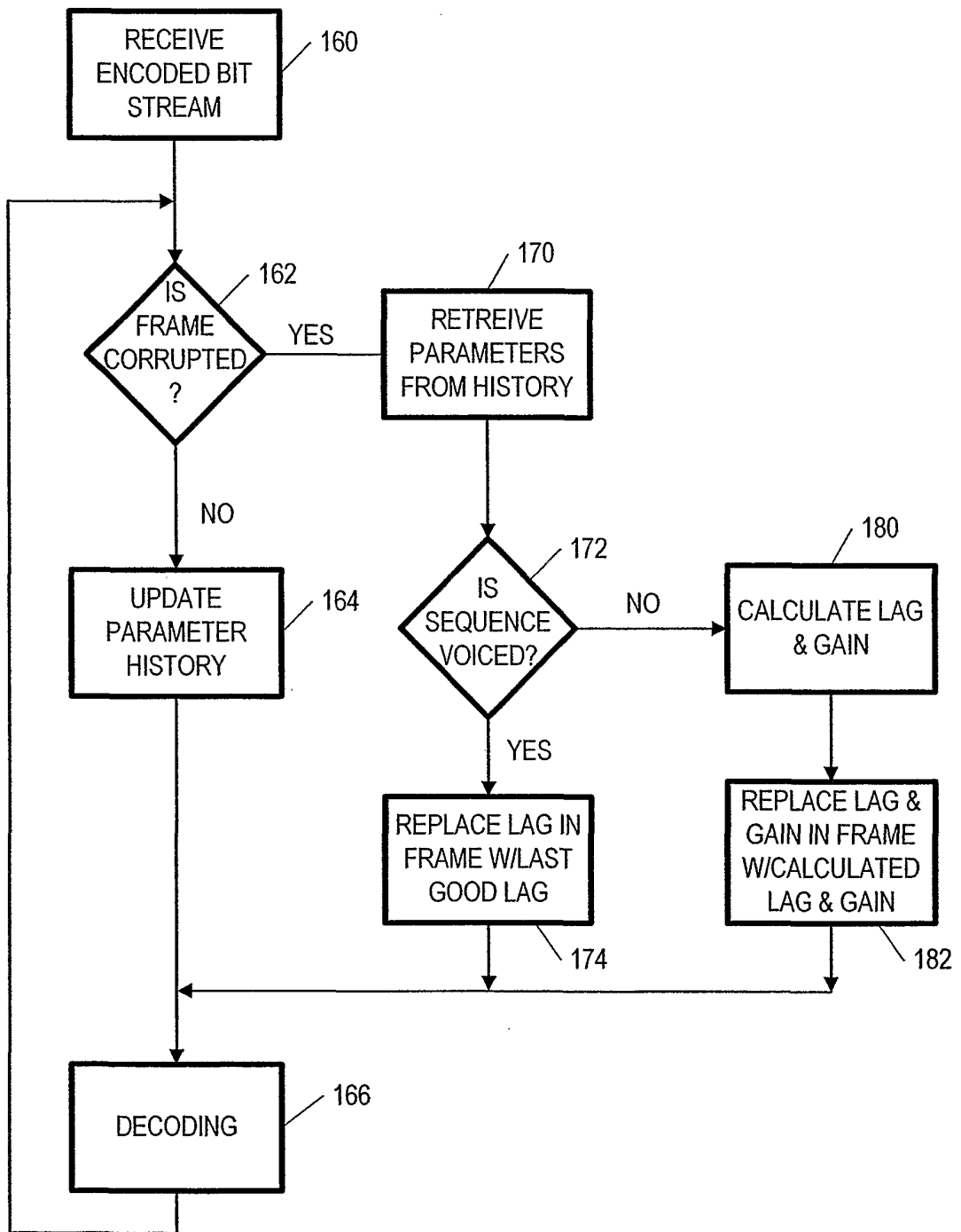

FIG. 4

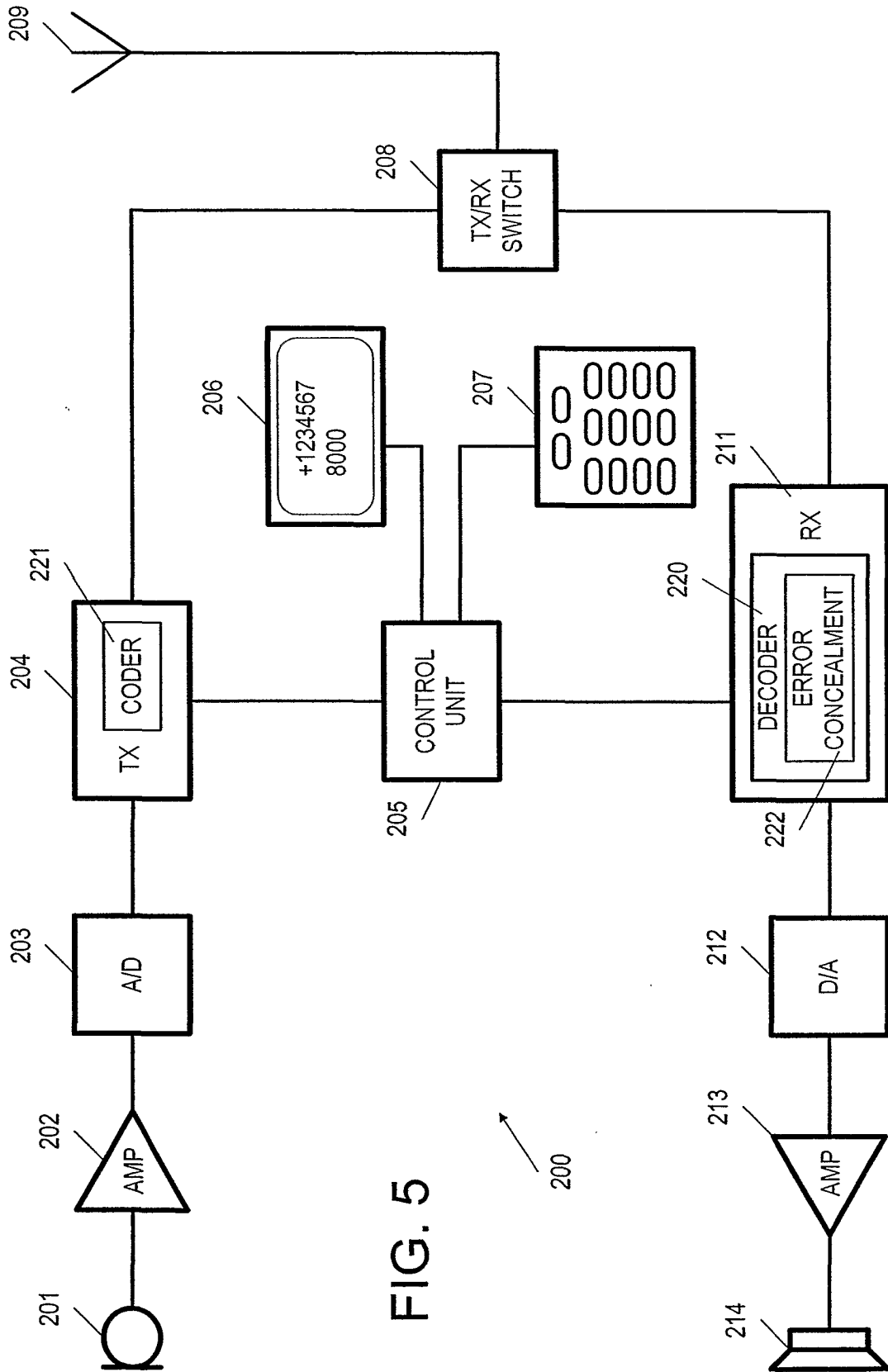

FIG. 5

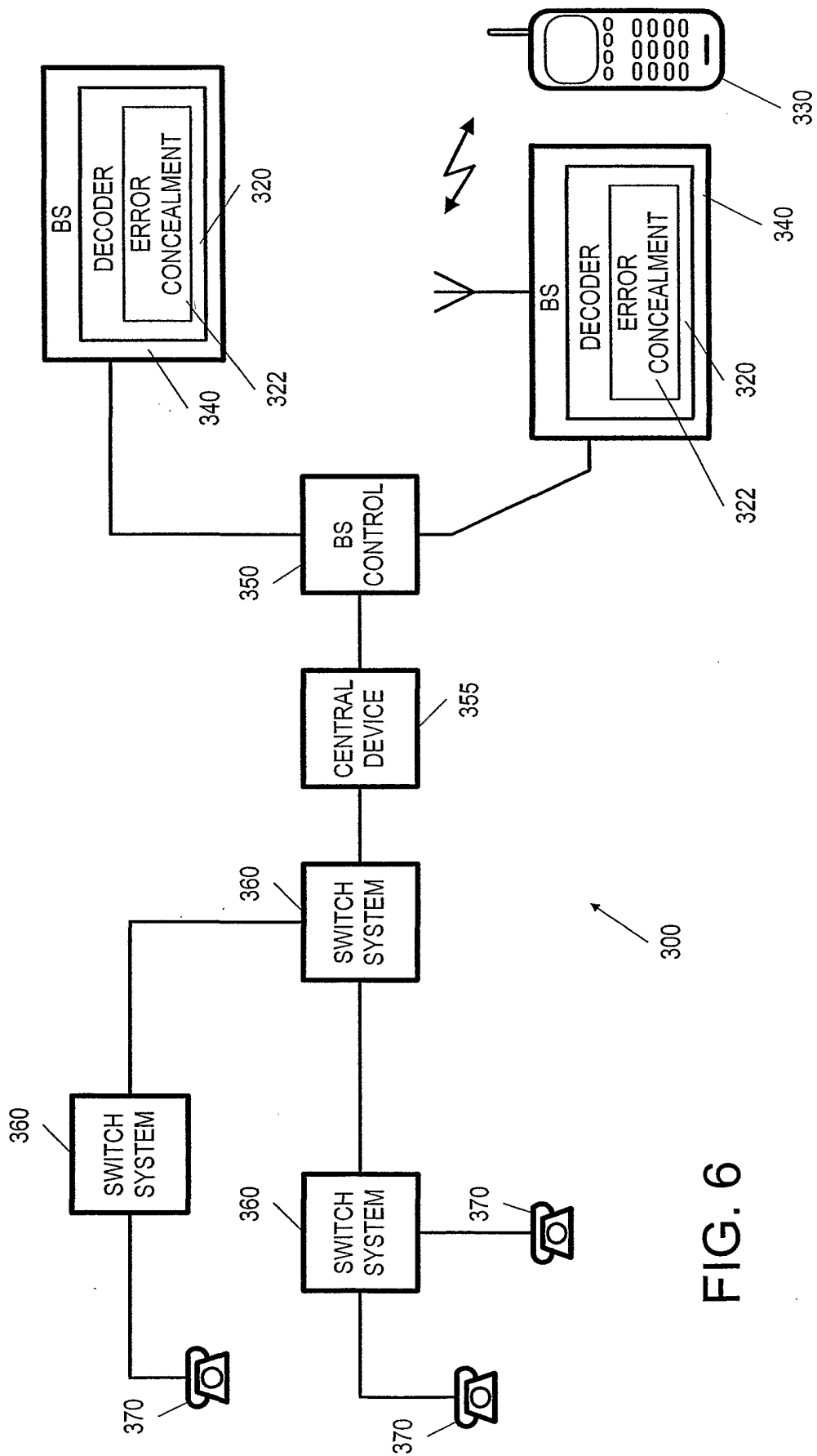

FIG. 6

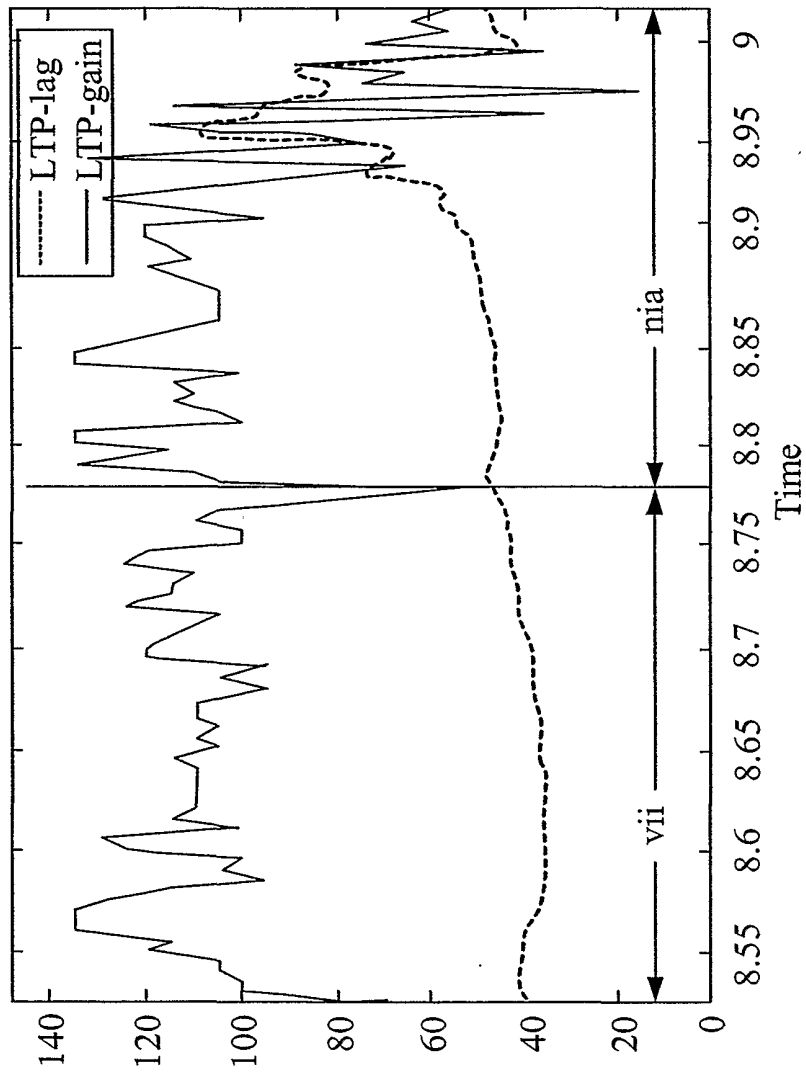

FIG. 7

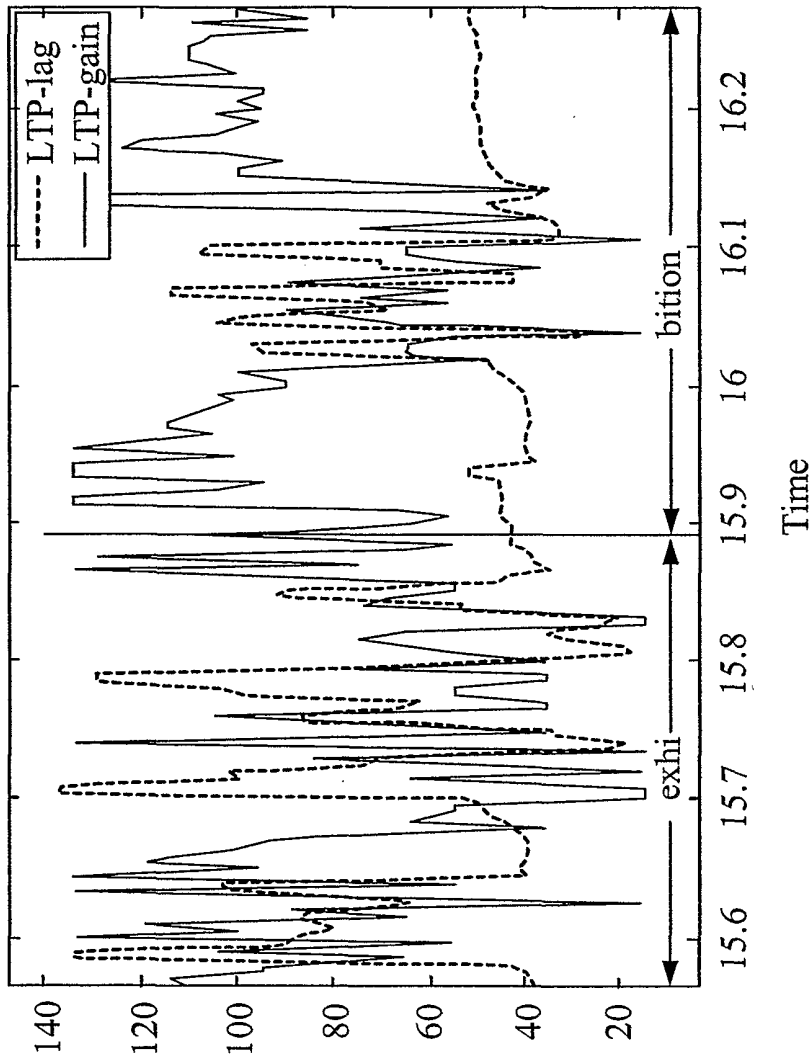

FIG. 8

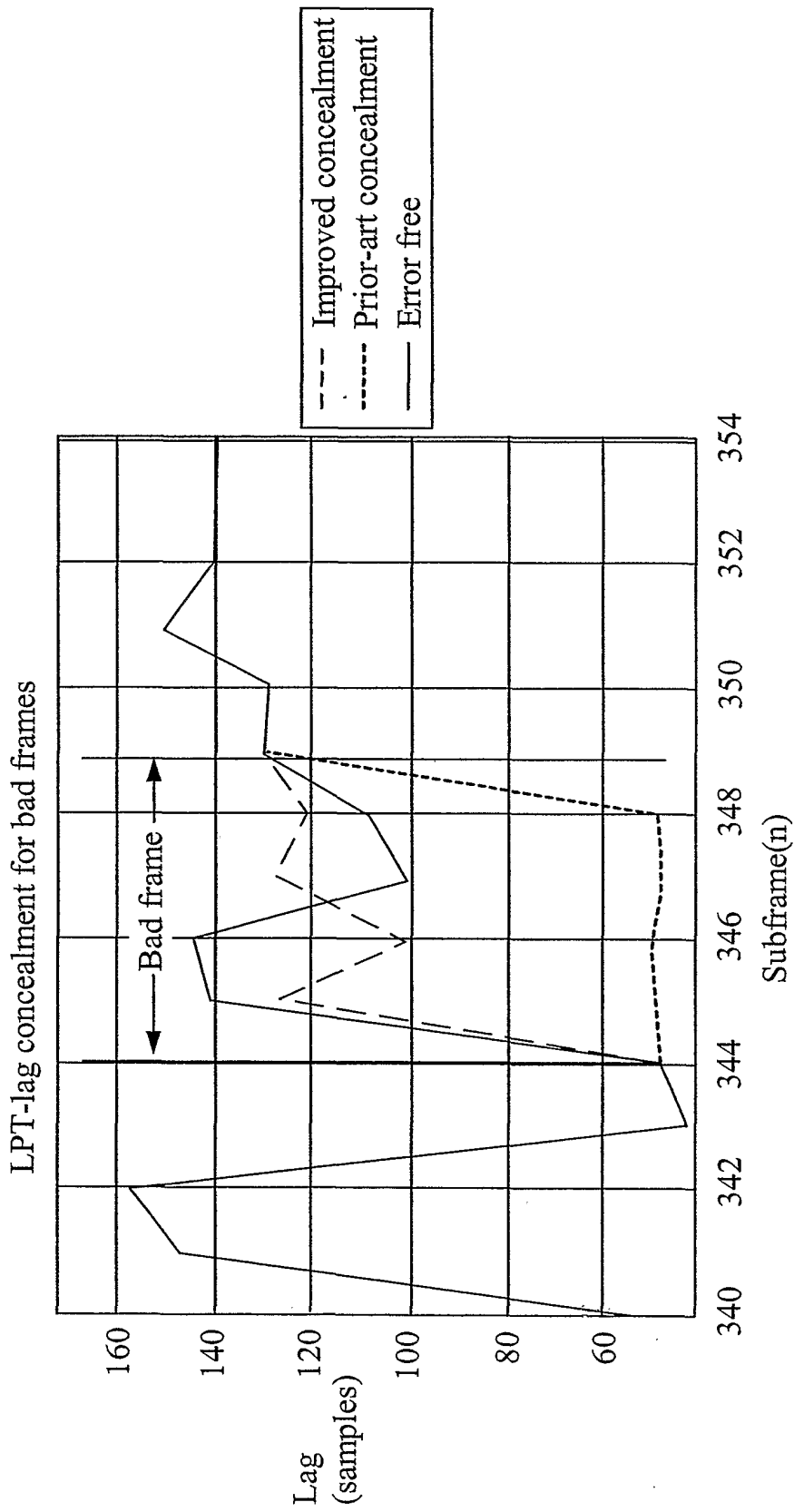

FIG. 9

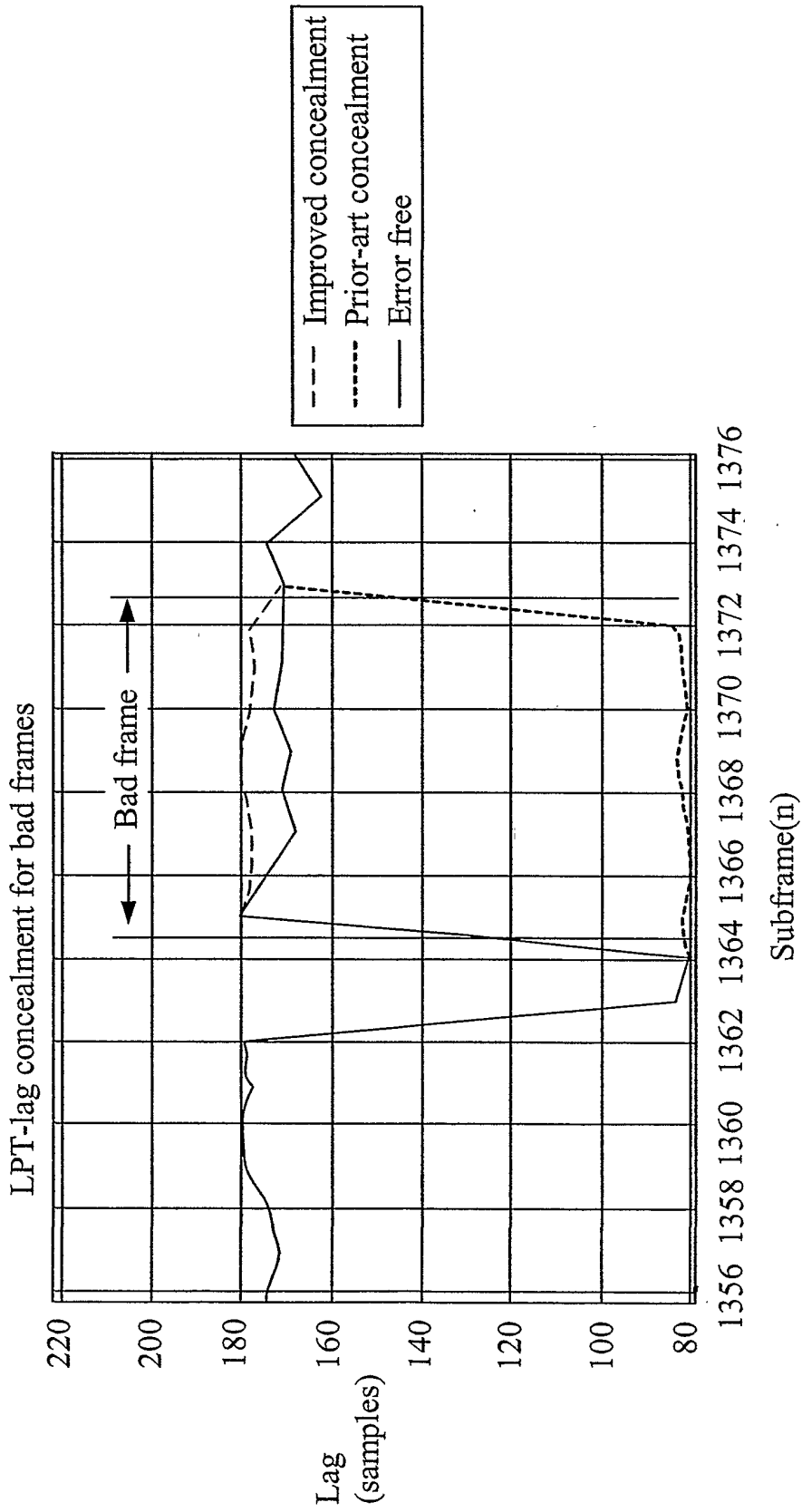

FIG. 10

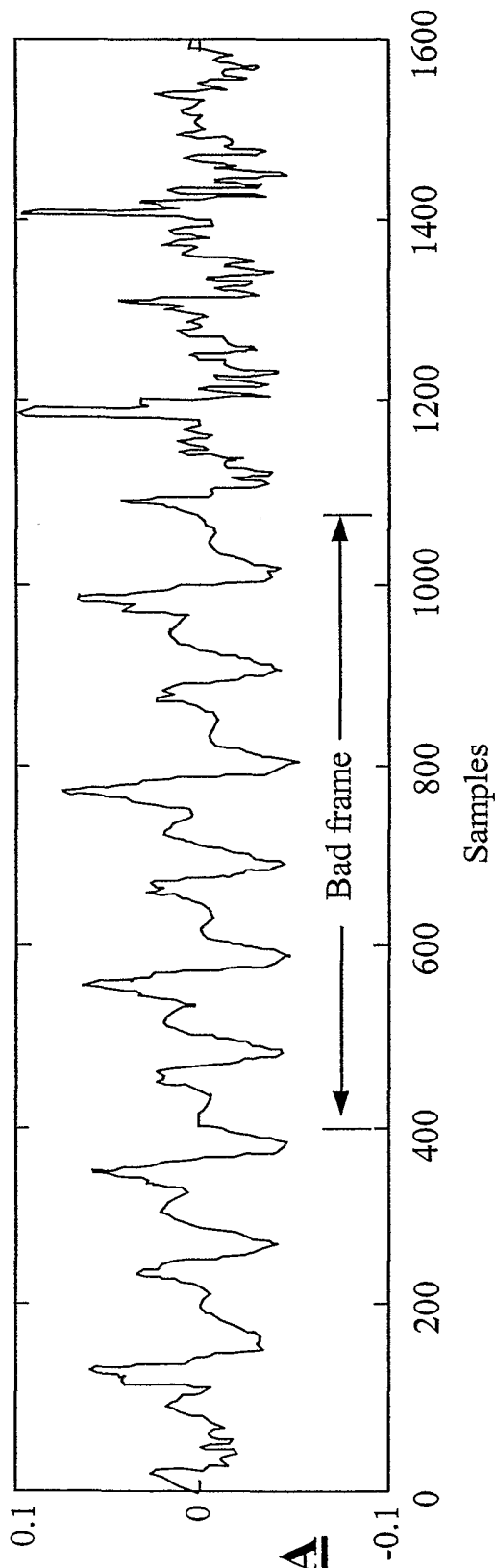

FIG. 11A

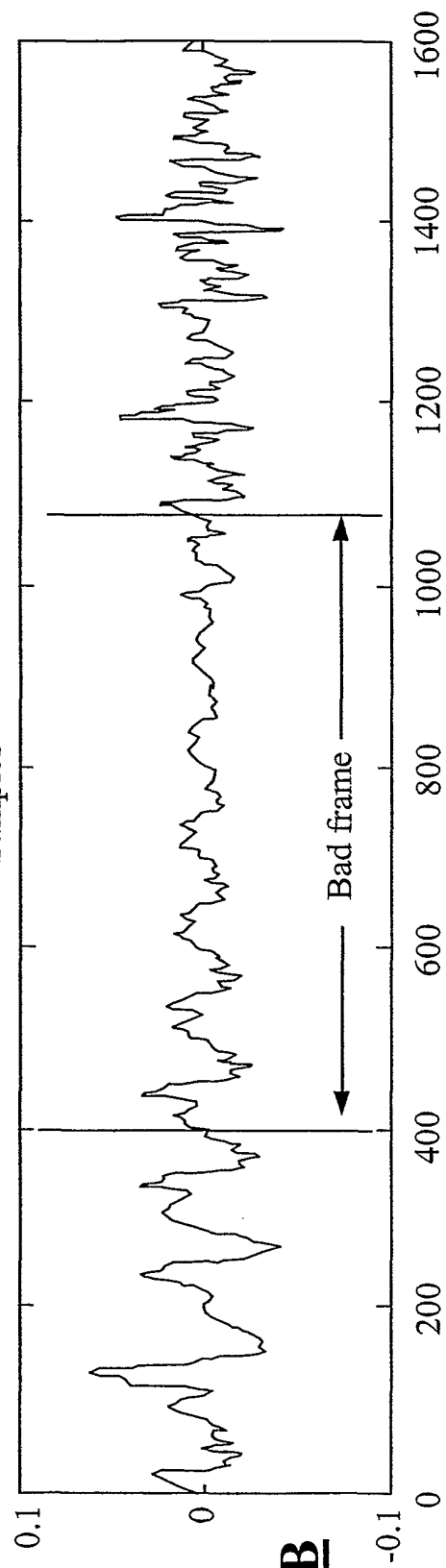

FIG. 11B

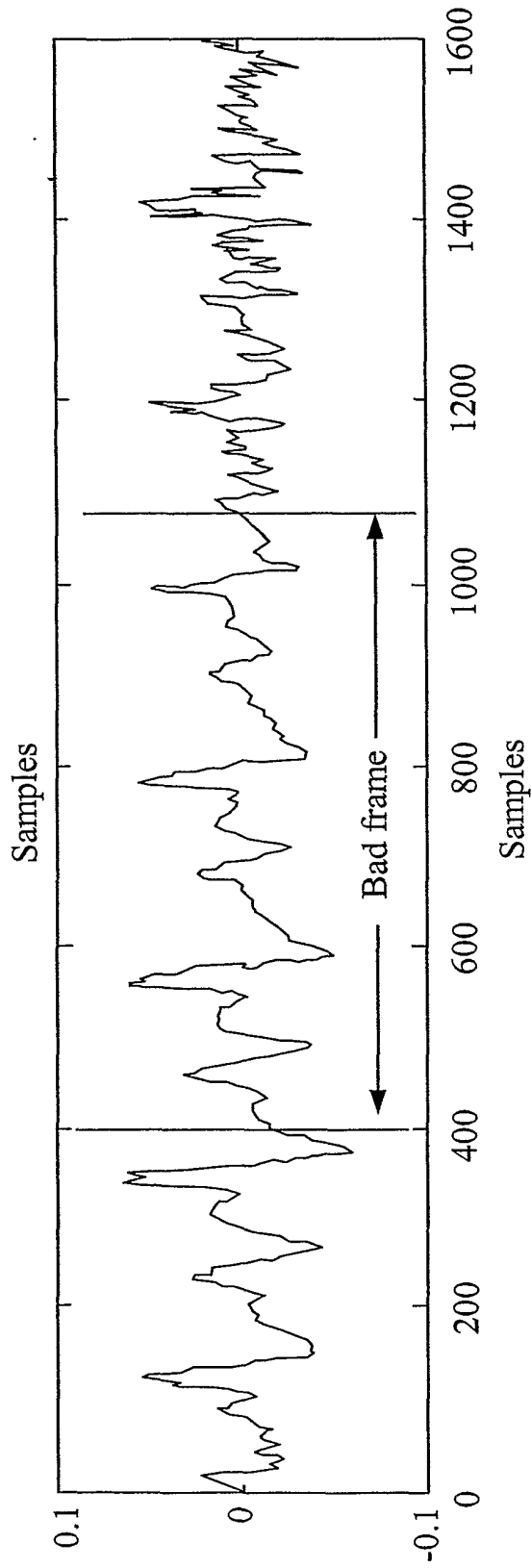

FIG. 11C

INTERNATIONAL SEARCH REPORT

International Application No
PCT/IB 01/02021

A. CLASSIFICATION OF SUBJECT MATTER IPC 7 G10L19/00		
According to International Patent Classification (IPC) or to both national classification and IPC		
B. FIELDS SEARCHED		
Minimum documentation searched (classification system followed by classification symbols) IPC 7 G10L		
Documentation searched other than minimum documentation to the extent that such documents are included in the fields searched		
Electronic data base consulted during the international search (name of data base and, where practical, search terms used) EPO-Internal, WPI Data, INSPEC		
C. DOCUMENTS CONSIDERED TO BE RELEVANT		
Category °	Citation of document, with indication, where appropriate, of the relevant passages	Relevant to claim No.
T	J. MAKINEN, J. VAINIO, H. MIKKOLA AND J. ROTTOLA-PUKKILA: "Improved substitution for erroneous LTP-parameters in a speech decoder" NORSIG SYMPOSIUM 2001, 18 - 20 October 2001, XP002195905 Trondheim the whole document	1-30
	--- -/--	
<input checked="" type="checkbox"/> Further documents are listed in the continuation of box C.		
<input checked="" type="checkbox"/> Patent family members are listed in annex.		
° Special categories of cited documents :		
A document defining the general state of the art which is not considered to be of particular relevance *E* earlier document but published on or after the international filing date *L* document which may throw doubts on priority claim(s) or which is cited to establish the publication date of another citation or other special reason (as specified) *O* document referring to an oral disclosure, use, exhibition or other means *P* document published prior to the international filing date but later than the priority date claimed	*T* later document published after the international filing date or priority date and not in conflict with the application but cited to understand the principle or theory underlying the invention *X* document of particular relevance; the claimed invention cannot be considered novel or cannot be considered to involve an inventive step when the document is taken alone *Y* document of particular relevance; the claimed invention cannot be considered to involve an inventive step when the document is combined with one or more other such documents, such combination being obvious to a person skilled in the art. *&* document member of the same patent family	
Date of the actual completion of the international search 15 April 2002	Date of mailing of the international search report 25/04/2002	
Name and mailing address of the ISA European Patent Office, P.B. 5818 Patentlaan 2 NL - 2280 HV Rijswijk Tel. (+31-70) 340-2040, Tx. 31 651 epo nl, Fax: (+31-70) 340-3016	Authorized officer Quélavoine, R	

INTERNATIONAL SEARCH REPORT

International Application No
PCT/IB 01/02021

C.(Continuation) DOCUMENTS CONSIDERED TO BE RELEVANT

Category *	Citation of document, with indication, where appropriate, of the relevant passages	Relevant to claim No.
A	<p>TSG-SA CODEC WORKING GROUP: "3G TS 26.091" TECHNICAL SPECIFICATION GROUP SERVICES AND SYSTEM ASPECTS, 26 - 28 April 1999, XP002195906 Yokohama * section 6.2.2, the two first lines * * section 6.2.3.2 LTP-lag update * * section 7.2.2, the two first lines * * section 7.2.3.1 LTP-lag update *</p>	<p>1,5,11, 16,21,26</p>
A	<p>US 6 188 980 B1 (THYSSEN JES) 13 February 2001 (2001-02-13) abstract column 2, line 47-63 column 10, line 17-20 column 13, line 5-7 column 14, line 21-29 column 41, line 19-22 & WO 00 11651 A 2 March 2000 (2000-03-02)</p>	<p>1,5,11, 16,21,26</p>

INTERNATIONAL SEARCH REPORT

Information on patent family members

International Application No

PCT/IB 01/02021

Patent document cited in search report	Publication date	Patent family member(s)	Publication date
US 6188980	B1	13-02-2001	WO 0011651 A1 02-03-2000
			EP 1105871 A1 13-06-2001
			EP 1105872 A1 13-06-2001
			EP 1105870 A1 13-06-2001
			EP 1110209 A1 27-06-2001
			EP 1194924 A1 10-04-2002
			TW 448417 B 01-08-2001
			TW 440813 B 16-06-2001
			TW 440814 B 16-06-2001
			TW 448418 B 01-08-2001
			WO 0011658 A1 02-03-2000
			WO 0011652 A1 02-03-2000
			WO 0011655 A1 02-03-2000
			WO 0011659 A1 02-03-2000
			WO 0011648 A1 02-03-2000
			WO 0011653 A1 02-03-2000
			WO 0011649 A1 02-03-2000
			WO 0011656 A1 02-03-2000
			WO 0011660 A1 02-03-2000
			WO 0011650 A1 02-03-2000
			WO 0011661 A1 02-03-2000
			WO 0011657 A1 02-03-2000
			WO 0011654 A1 02-03-2000
			US 2001023395 A1 20-09-2001
			US 6104992 A 15-08-2000
			US 6330531 B1 11-12-2001
			US 6260010 B1 10-07-2001
			US 6173257 B1 09-01-2001
			US 6240386 B1 29-05-2001