

[54] CLIP
 [75] Inventor: Taizo Noda, Nishinomiya, Japan
 [73] Assignee: Kohshoh Limited, Kyoto, Japan
 [22] Filed: Mar. 24, 1975
 [21] Appl. No.: 561,207

809,905	1/1906	Brockway.....	24/250 R UX
830,759	9/1906	Andresen	24/250 HE
1,604,718	10/1926	Pflantzer	24/248 FS
3,780,402	12/1973	Takabayashi.....	24/250 HE

FOREIGN PATENTS OR APPLICATIONS

986,234	3/1951	France.....	24/252 HE
---------	--------	-------------	-----------

Primary Examiner—Donald A. Griffin

[52] U.S. Cl. 24/250 HE; 24/248 HE
 [51] Int. Cl.² A44B 21/00
 [58] Field of Search ... 24/243 FS, 243 HE, 243 GC,
 24/250 R, 250 HE, 248 SB, 248 E, 248 L,
 252 HE, 252 CP, 252 BC, 252 GC, 252 DP,
 137 A, 248 GC, 238 HE, 248 FS

[57] ABSTRACT

A clip comprises a first and a second members each comprising a base plate having a jaw at the front end thereof and being pivotally connected to the other, a spring for biasing said jaws in open position and an operating member removably mounted on said plate members for holding said jaws in closed position.

[56] References Cited
 UNITED STATES PATENTS
 410,855 9/1889 Rubin 24/248 HE

9 Claims, 13 Drawing Figures

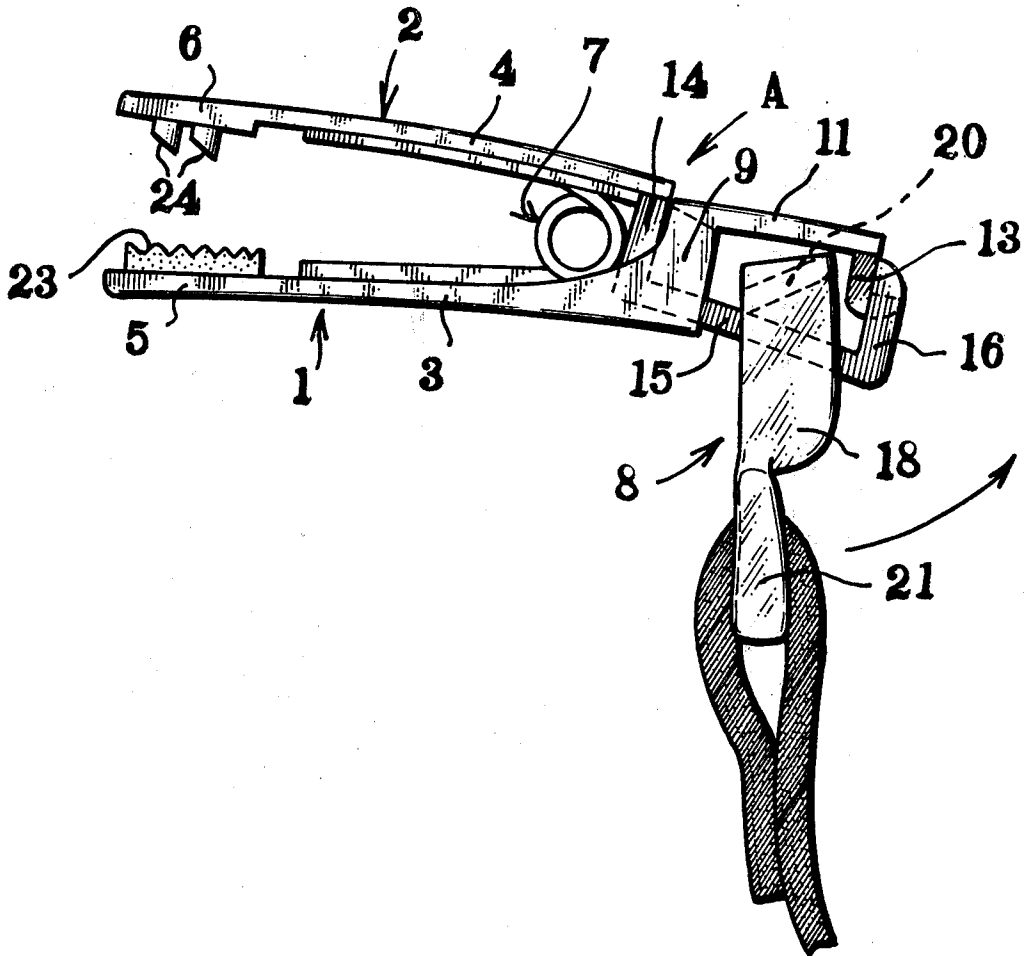

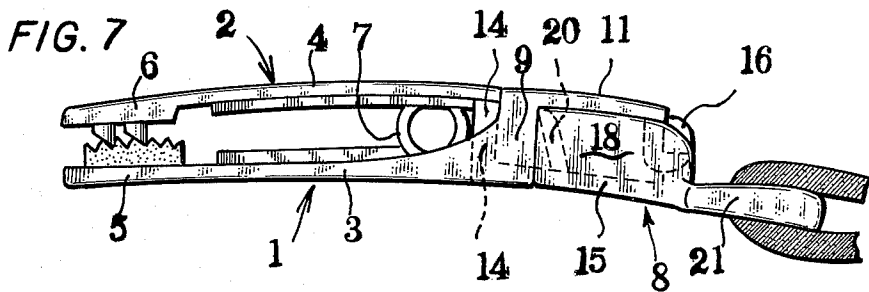
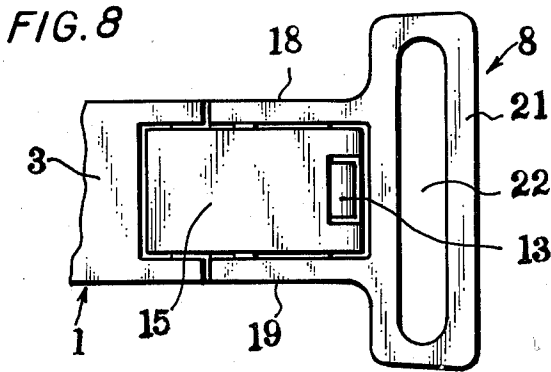
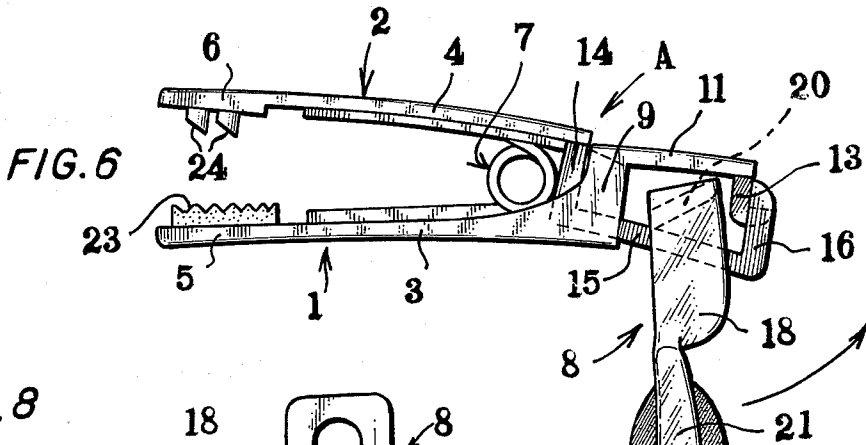
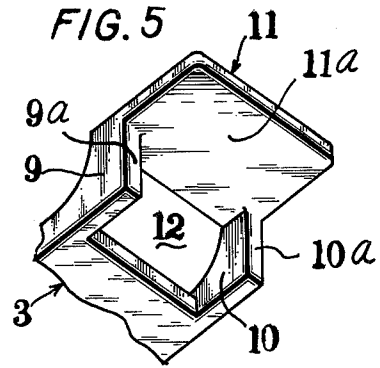
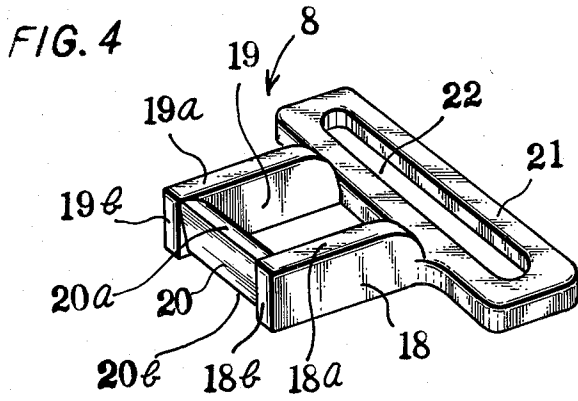

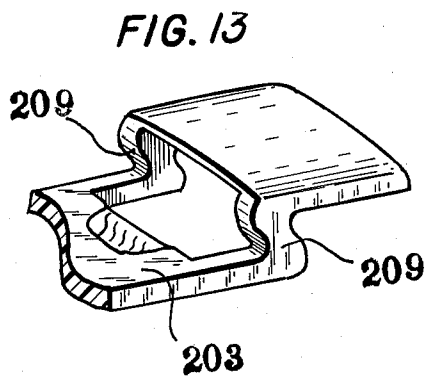
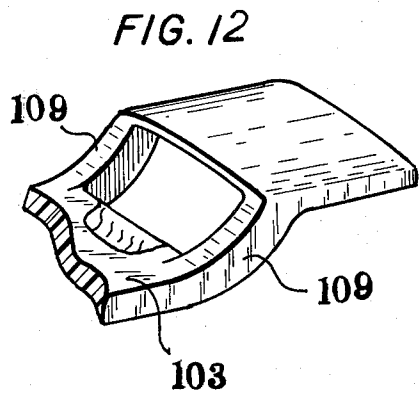
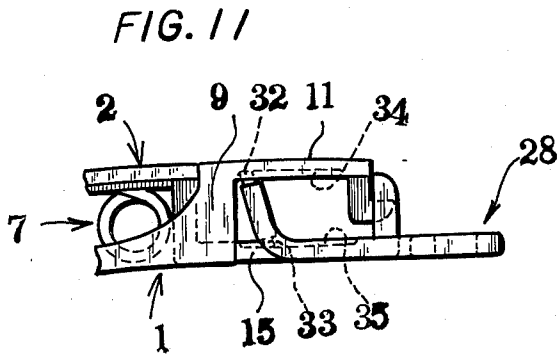
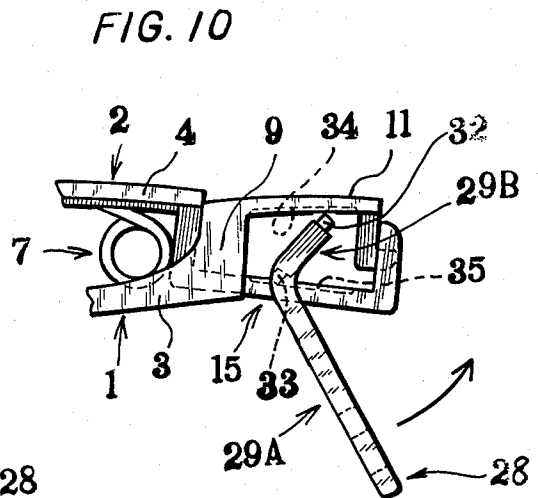
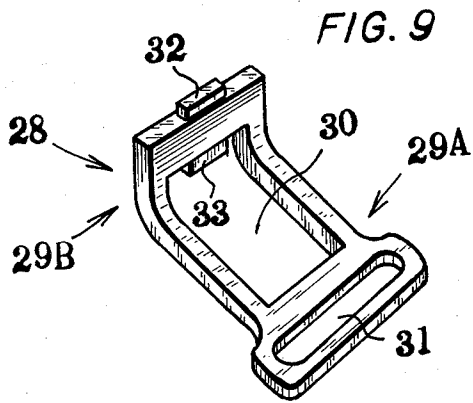

DETAILED DESCRIPTION OF THE INVENTION

The present invention relates to a clip, particularly a clip to be worn through an article of clothing on a human body e.g. a fastener for a suspender or a clip attached to the end of a girdle, or a clothespin or one of other similar clips.

Such a clip generally comprises metal or plastic plate members pivotally connected to each other. In the conventional clip, such a pivotal connection is effected by a shaft separately formed of metal or the like or integrally formed with plate members and bearings integral with said plate members. Such a shaft and bearings on one hand make complicate the construction of the plate members, requiring an extra space and producing a number of uneven portions on the outer surface of a clip, thus providing the clip with a bad appearance and an uncomfortable touch in wearing, and on the other hand they make it difficult to manufacture and assemble the clip, inevitably resulting in a high cost of the obtained clip. Further, in a conventional clip, since such a pivotal portion is located in the center of the length of the plate members, the resiliency of the plate members is divided at said central position. Therefore, in the front half of the clip including jaws or clipping sections, only substantially the same extent of resiliency is made use of as in the rear half, thus failing in effective clipping and limiting the thickness of an article to be clipped.

An object of the present invention is to provide a clip wherein the construction of pivotal connection between plate members is improved so as to provide smooth and flat outer surfaces to said clip and to make compact the total construction thereof, whereby the touch and an appearance of said clip are improved.

Another important object of the present invention is to provide a clip which can be easily manufactured and assembled.

A further object of the present invention is to provide a clip which can surely receive an article to be clipped between plate members and firmly and effectively clip the same.

For achieving these objects, a clip according to the present invention comprises a first and a second plate members each comprising a base plate having a jaw at the front end thereof and being pivotally connected to the other, a spring for biasing said jaws in open position and an operating member removably mounted on said plate members for holding said jaws in closed position, at the rear end of said base plate of said first plate member provided being a pair of side ribs substantially vertically upwardly extending from the upper surface of said base plate, said side ribs being bridged by means of a first auxiliary plate rearwardly extending from the rear end of said base plate substantially in parallel with said base plate so as to define an opening between said first auxiliary plate and said base plate, while at the rear end of said base plate of said second plate member provided is a lateral rib downwardly extending from the lower surface of said base plate across the longitudinal direction of the base plate and connected at the lower end thereof to a second auxiliary plate, which extends behind the rear end of said base plate substantially in parallel with said base plate, adapted to be passed through said opening in the first plate member and arranged behind the rear end of the base plate of the first

plate member so as to be located substantially in alignment with said base plate when the jaws are in closed position, while the first auxiliary plate is adapted to be arranged behind the rear end of the base plate of the second plate member and opposite to the second auxiliary plate so as to be located substantially in alignment with the base plate of the second plate member.

These objects and advantages of the present invention will appear more fully in the following description given with reference to the appended drawings, in which:

FIG. 1 is a perspective view of an embodiment of a clip according to the present invention;

FIG. 2 is a perspective view of a first plate member of the clip of FIG. 1;

FIG. 3 is a perspective view of a second plate member of the clip of FIG. 1;

FIG. 4 is a perspective view of an operating member of the clip of FIG. 1;

FIG. 5 is a perspective view of the rear end portion of the first plate member;

FIG. 6 is a side view of the clip in open position;

FIG. 7 is a side view of the clip in closed position;

FIG. 8 is a bottom view of a portion of the clip of FIG. 7;

FIG. 9 is a perspective view of a modified embodiment of an operating member;

FIGS. 10 and 11 are views for illustration of the operation of the operating member of FIG. 9 with jaws being opened by said operating member in FIG. 10 and closed thereby in FIG. 11; and

FIGS. 12 and 13 are perspective views of embodiments of side ribs of a first member.

As shown in the drawings, a clip according to the present invention comprises a first and second members 1, 2 pivotally connected to each other, base plates 3, 4 constituting these plate members, a spring 7 for biasing the front end portions or jaws 5, 6 of the base plates in open position and an operating member 8 for holding said jaws 5, 6 in closed position. The first and second plate members 1, 2 and the operating member 8 are formed by injection molding of plastic material.

As shown especially in FIG. 2, from the upper surface of the rear end portion of the base plate 3 constituting the first plate member 1 integrally and substantially vertically upwardly extended are a pair of side ribs 9, 10 opposing to each other. The side ribs are bridged by a first auxiliary plate 11 suitably spaced from the base plate 3 and extending rearwardly from the rear end of the side rib substantially in parallel with the base plate 3 so as to define an opening 12 between the base plate 3 and the first auxiliary plate 11. The outer surface of each side rib is in the same plane with each side surface of the base plate 3. The first auxiliary plate 11 is provided at the rear end thereof with a substantially L-shaped hook portion 13 integrally extending from the lower surface of the plate 11.

The base plate 4 constituting the second plate member 2 is provided at the rear end thereof with a lateral rib 14 substantially vertically downwardly extending from the lower surface of the base plate 4 across the longitudinal direction of the plate 4. To the lower end of the lateral rib 14 connected is a second auxiliary plate 15 extending behind the base plate 4 substantially in parallel therewith.

Further, a receiving portion 16 extends vertically upwardly from the rear end of the second auxiliary plate

15. Between the receiving portion 16 and the auxiliary plate 15 provided is an opening 17 with which the hook portion 13 is adapted to be engaged.

The second auxiliary plate 15 is adapted to pass the opening 12 in the first plate member 1 so as to be disposed behind the base plate 3 of the member 1 and opposite to the first auxiliary plate 11 or below the same. Thereby, when the jaws 5, 6 are in closed position, the lower surface of the second auxiliary plate 15 is in substantially the same continuous plane with the lower surface of the base plate 3 of the member 1 while the upper surface of the first auxiliary plate 11 is in substantially the same continuous plane with the upper surface of the base plate 4 of the member 2.

As shown in FIG. 4, the operating member 8 comprises a pair of side walls 18, 19 extending in parallel with the longitudinal axis of the plate members 1, 2, an operating wall 20 extending across the longitudinal axis of the plate members 1, 2 and connecting the side walls 18, 19 to each other at the front end thereof and a holding portion 21 connected to the rear end of the side walls 18, 19 and provided with a slot 22 for fitting one end of a band or belt or the like therethrough. Since such a slot is provided for the purpose of connecting a band or the like to the operating member 8 in case of using the clip in a suspender and the like, it may be omitted when the clip is individually used e.g. as a clothespin.

The side walls 18, 19 are substantially aligned with the side ribs 9, 10 of the first plate member 1 and adapted to have the outer surface substantially in the same plane with each outer surface of the side ribs 9, 10 when the jaws are in closed position. The side walls 18, 19 and the operating wall 20 are adapted to be disposed between the first and second auxiliary plates 11, 15 whereby in case of the jaws 5, 6 being in closed position the upper end surfaces 18a, 19a of the side walls 18, 19 are engaged with the lower surface 11a of the first auxiliary plate 11, while the front end surfaces 18b, 19b thereof are engaged with the rear end surfaces 9a, 10a of the side ribs 9, 10, with the upper and lower end surfaces 20a, 20b being engaged with the lower surface 11a of the first auxiliary plate 11 and the upper surface of the second auxiliary plate 15 respectively.

On the jaw 5 of one base plate 3 mounted is a resilient pad 23 with a waved surface and on the jaw 6 of the other base plate 6 provided are a plurality of projections 24 integral with said plate 6 and having inclined faces. Such a resilient pad and such projections may be provided on both of the jaws.

The spring 7 is fitted into recesses 25, 25 provided in the center of the base plates 3, 4, each end portion of the spring being engagedly fitted into longitudinal grooves 26, 26 in the base plates.

Referring to FIG. 6, the clip A is in open position wherein the side walls 18, 19 and the operating wall 20 of the operating member 8 are swingable between the first and second auxiliary plates, while the base plate 4 of the second plate member 2 is pushed up by means of the spring 7 so as to locate the upper surface of the plate 4 above the upper surface of the second auxiliary plate 11, and the receiving portion 16 at the rear end of the plate 15 is engaged through the opening 17 with the hook portion 13 of the first auxiliary plate 11.

By manually pivoting the holding portion 21 from the position shown in FIG. 6 in the direction of the arrow therein, the upper and lower end surfaces 20a, 20b

slide in the opposite directions respectively with respect to the opposing surfaces 11a, 15a of the auxiliary plates 11, 15, thus the second auxiliary plate 15 being pulled rearwardly, whereby the lateral rib and a part of the auxiliary plate adjacent thereto are pivoted in the opening 12 thereby displacing the jaw 6 of the base plate 4 near the opposing jaw 5. And finally, the clip A can be in such closed position as shown in FIG. 7.

The operating wall 20 of the operating member 8 should be rather suitably forwardly inclined than disposed vertical to the longitudinal axis of the side wall 18 or 19 because the plate members 1, 2 can be thereby surely locked in closed position.

Referring to FIG. 9, another type of a L-shaped operating member 28 includes a tail portion 29A and a clip-engaging portion 29B extending substantially vertical to said tail portion 29A. Further, this operating member 28 has a central opening 30. The tail portion 29A is provided with a slot 31 for fitting one end of a band or belt therethrough. The clip-engaging portion 29B is provided with a pair of projections 32, 32 extending substantially vertical to the tail portion 29A. In use, the operating member 28 is engaged through the central opening 30 with the second auxiliary plate 15 as shown in FIG. 10. The projections 32, 33 of the clip-engaging portion 29 are adapted to be engaged with grooves 34, 35 provided in the lower surface of the first auxiliary plate 11 and the upper surface of the second auxiliary plate 15 respectively.

In FIG. 10, the jaws in the base plates 3, 4 are in open position, wherein the clip-engaging portion 29B of the operating member is swingable between the auxiliary plates 11, 15. By pivoting the tail portion 29A from the position in FIG. 10 in the direction of the arrow therein, the jaws of the base plates are closed as shown in FIG. 11 and in this position the projections 32, 33 of the clip-engaging portion are engaged with the grooves 34, 35 in the auxiliary plates.

In FIGS. 12, 13, modified embodiments of the side ribs of the first plate member. Side ribs 109, 109 in FIG. 10 upwardly and rearwardly extend from the upper surface of a base plate 103 at the rear end thereof while side ribs 209, 209 in FIG. 13 extend upwardly and forwardly from the upper surface of the base plate 203 at the rear end thereof.

As mentioned above, a clip according to the present invention has a simple construction requiring neither a shaft nor bearings, thus facilitating to manufacture and assemble the same and lowering the cost thereof.

A clip according to the present invention has, in use, substantially flat outer surfaces or flat upper, lower and two side surfaces, thereby providing a good touch in wearing and an excellent appearance.

Further, a clip according to the present invention has a pivotal portion at the rear end portion of the plate members thereby affording to make the most of resiliency of plate members at the jaws thereof and thus to surely and firmly clip an article without limitation by the thickness of the article. Further, according to this clip, a large resilient effect is achieved even if it is of a small size.

What I claim is:

1. A clip comprising a first and a second plate members each comprising a base plate having a jaw at the front end thereof and being pivotally connected to the other, a spring for biasing said jaws in open position and an operating member removably mounted on said

5

6

plate members for holding said jaws in closed position, in which at the rear end of said first plate member are provided a pair of side ribs upwardly extending from the upper surface of said base plate, said side ribs being bridged by means of a first auxiliary plate rearwardly extending from the rear end of said base plate substantially in parallel with said base plate so as to define an opening between said first auxiliary plate and said base plate, while at the rear end of said base plate of said second plate member is provided a lateral rib downwardly extending from the lower surface of said base plate and connected at the lower end thereof to a second auxiliary plate, which extends behind the rear end of said base plate substantially in parallel with said base plate, adapted to be passed through said opening in the first plate member and arranged behind the rear end of the base plate of the first plate member so as to be located substantially in alignment with said base plate when the jaws are in closed position, while the first auxiliary plate is adapted to be arranged behind the rear end of the base plate of the second auxiliary plate so as to be located substantially in alignment with said base plate.

2. A clip as claimed in claim 1, wherein said operating means comprises a pair of side walls extending in parallel with the longitudinal axis of said plate members, an operating wall extending across the longitudinal direction of said plate members and connecting said side walls to each other at the front ends of said side walls, and a holding portion connected to the rear ends of said side walls, said side walls and said operating wall being pivotally arranged between said auxiliary plates and the upper and lower end surfaces of said operating wall being adapted to be in contact with the opposing surfaces (i.e. inner surfaces) of said auxiliary plates when said jaws are in closed position.

3. A clip as claimed in claim 2, wherein the outer surface of each side rib, the side surface of said base plate of said first plate member and the side surface of said

first auxiliary plate are in the same plane, and these surfaces are also in the same plane with the side surface of said base plate of said second plate member and the outer surface of said side wall of said operating member.

4. A clip as claimed in claim 3, wherein the front and upper end surfaces of said side walls in said operating member are adapted to be engaged with the rear end surfaces of said side ribs of said first plate member and the lower surface of said first auxiliary plate.

5. A clip as claimed in claim 2, wherein said holding portion of said operating member is provided with a slot for fitting one end of a band, belt or the like therethrough.

6. A clip as claimed in claim 1, wherein said operating member is substantially L-shaped and removably mounted on said second auxiliary plate, and comprises a tail portion and a clip-engaging portion extending substantially vertical to said tail portion, between said two portions provided being a central opening so that said second auxiliary plate extends through said opening when said jaws are in open position.

7. A clip as claimed in claim 6, wherein said tail portion of said operating member is provided with a slot for fitting one end of a belt, band or the like therethrough.

8. A clip as claimed in claim 1, wherein said first auxiliary plate is provided at its rear end with a substantially L-shaped hook portion while said second auxiliary plate is provided at its rear end with an upwardly projecting receiving portion so as to define an opening between said receiving portion and said second auxiliary plate, whereby said hook portion is adapted to be engaged through said opening with said receiving portion.

9. A clip as claimed in claim 1, wherein each jaw of said base plates is provided with an anti-slipping means.

* * * * *

5

10

15

20

25

30

35

40

45

50

55

60

65

UNITED STATES PATENT OFFICE
CERTIFICATE OF CORRECTION

Patent No. 3,914,828

Dated October 28, 1975

Inventor(s) Taizo Noda

It is certified that error appears in the above-identified patent and that said Letters Patent are hereby corrected as shown below:

On the cover sheet item [30] should read

Japan

23039/75

February 24, 1975.

Signed and Sealed this

eighth Day of June 1976

[SEAL]

Attest:

RUTH C. MASON
Attesting Officer

C. MARSHALL DANN
Commissioner of Patents and Trademarks