

1a 1b

2

3

4

5

<

12a : 110 :

112 : 120 : 가

122 : 가 124 :

130 : 140 :

150 : 가 160 :

(Standard Mechanical Interface, SMIF

) SMIF

SMIF Standard Mechanical Interface

, SMIF

가

MIF SMIF SMIF S

1a SMIF

, SMIF (10) (pod door, 11), (11)
(15) (15) (16) (11)
(16) (12a,)가 (12a)
(16) SMIF (10) SMIF (10) SMIF
(10) (12)가 (11) SMIF (10) SMIF
(12) (12)

(11) (16)가 (11) (16)

, 1b (11) 3 (11a) (14)

(13) (11a) (13) (14) (25)

SMIF (10) SMIF (20)

(27) (11)

2 (pod latch, 23) , SMIF (20) (port plate, 21), ' L ' 가 (22),

(24) (21) SMIF (20) SMIF (10)가

, SMIF (10) , 가 (22) (21)

(23) L 가 SMIF (20) SMIF (10) SMIF (20)

(24) (11) ()

(11) (15) (25),

(26) (27) (25) (24) (11)

(11a) SMIF (10) 가 (27) (24)

(26) SMIF (10)가 (11) (13) (14) (11)

(16) IF (20) , (27) (14) , SMIF (10) (11)가 SM

(12a)가 (11) (11) (16) (13)

가 가 가

가 ,가 ,가

가 ,가

가 가

가

SMIF

3 , 4 5

1a , SMIF (10) (pod door, 11), (11)
 (15) (15) (16) , SMIF (10)
 (11) SMIF (10)
 (12)가 (12) (11)
 (16)가 (11) (16) (110)
 11) (12a)가 3 , (110)

3, 4 5

(110) 가 (110) (112),
 (112) 가 (120) (120) (122),
 (124) 가 (122) 가 (122) (130),
 (112) (130) 가 (130) (140)
 가 (150), 가 (120) 가 (120)
 (160) (112) , (160)
 (112) (16) (12a)

(15)가 (110)가 (140) ,가 (150)
 (112) (130) 가 (130)가 4 'A'
 가 (122) ,가 (122) 가 (120) 4 'B'
 , 5 ,가 (120) 'B' (160) 5
 C' (110) (16) (12a)
 (16) (110) () (15)

(57)

1.

가

,

;

가

가

;

가

,가

가

;

,

가

가

;

,

가

가

;

가

가

,

2.

1

,

1a

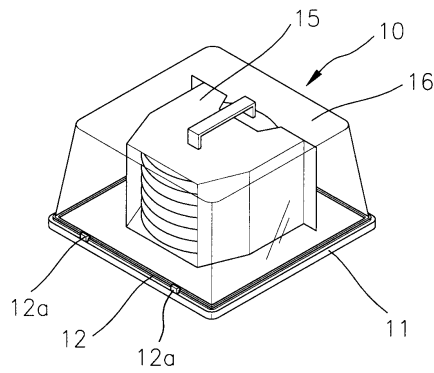

1b

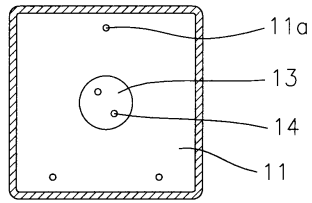

2

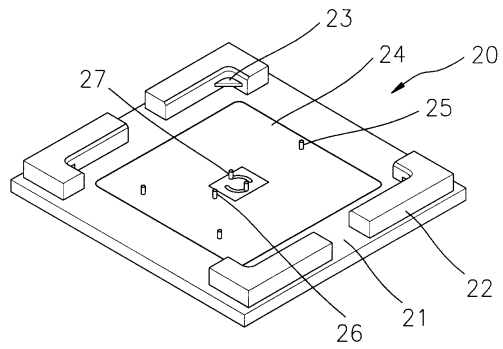

3

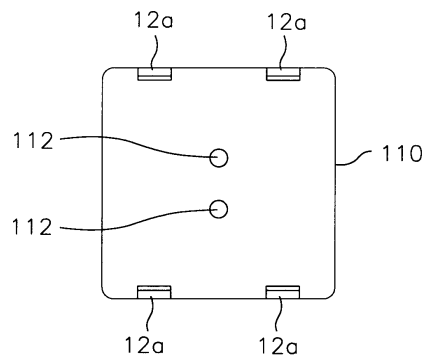

4

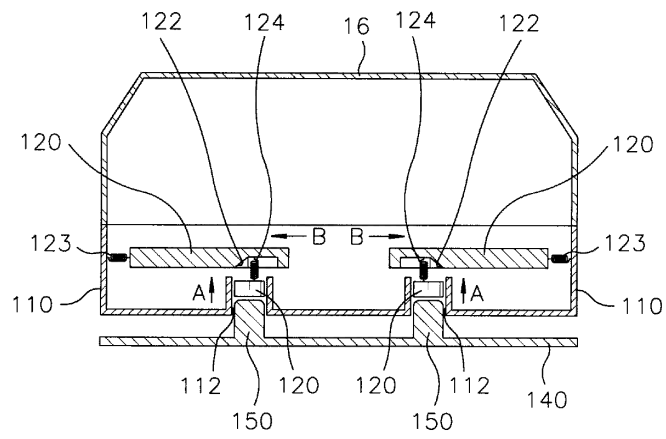

5

