

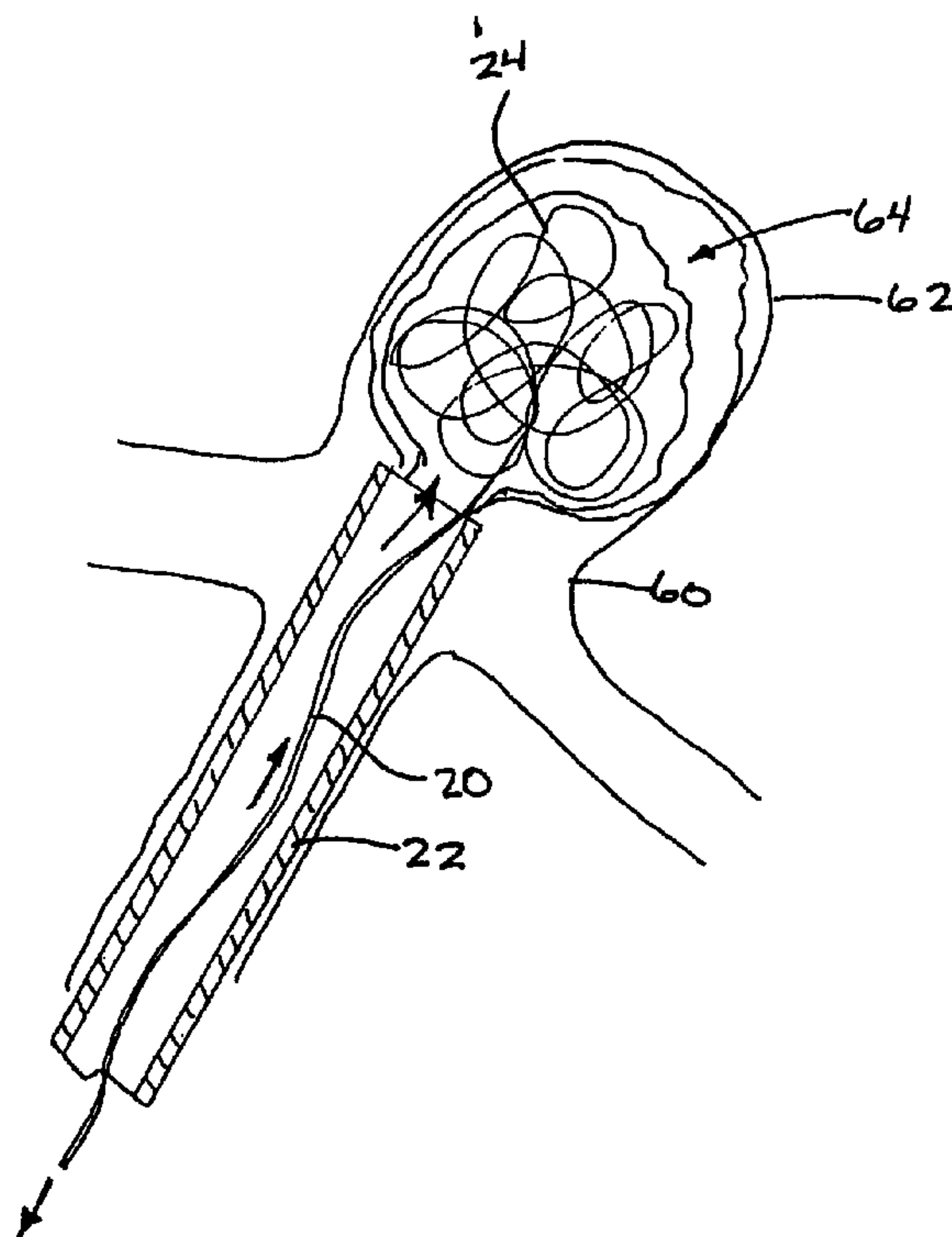

(86) Date de dépôt PCT/PCT Filing Date: 2000/08/07  
 (87) Date publication PCT/PCT Publication Date: 2001/03/08  
 (85) Entrée phase nationale/National Entry: 2002/01/11  
 (86) N° demande PCT/PCT Application No.: US 2000/040603  
 (87) N° publication PCT/PCT Publication No.: 2001/015608  
 (30) Priorité/Priority: 1999/08/31 (09/387,274) US

(51) Cl.Int.<sup>7</sup>/Int.Cl.<sup>7</sup> A61B 17/12  
 (71) Demandeur/Applicant:  
MICRO THERAPEUTICS, INC., US  
 (72) Inventeurs/Inventors:  
CRAGG, ANDREW H., US;  
WALKER, BLAIR D., US;  
PERL, JOHN II, US;  
JONES, MICHAEL, US;  
GREENE, GEORGE ROBERT, US;  
WALLACE, GEORGE, US;  
GREFF, RICHARD J., US  
 (74) Agent: TORYS LLP

(54) Titre : REGULATION DE L'INJECTION D'UNE COMPOSITION LIQUIDE D'EMBOLISATION  
 (54) Title: CONTROLLED INJECTION OF LIQUID EMBOLIC COMPOSITION



(57) Abrégé/Abstract:

A liquid embolic delivery system is provided for trapping an injected liquid embolic composition to prevent the liquid embolic from solidifying or otherwise passing outside of an embolization area. The delivery system includes a catheter for delivery of a liquid embolic composition and a containment member positioned at a distal end of the catheter which is shaped to trap the liquid embolic composition delivered through the lumen of the catheter. The containment member is formed as a brush, nest, sponge, swab, flexible sack, or other shape into and around which the liquid embolic composition is injected. The liquid embolic composition is trapped or meshes with the containment member during solidification containing the liquid embolic and preventing the embolic composition from passing into the blood stream.

## (12) INTERNATIONAL APPLICATION PUBLISHED UNDER THE PATENT COOPERATION TREATY (PCT)

(19) World Intellectual Property Organization  
International Bureau



(43) International Publication Date  
8 March 2001 (08.03.2001)

PCT

(10) International Publication Number  
**WO 01/15608 A1**

(51) International Patent Classification<sup>7</sup>: **A61B 17/12**

Costa Mesa, CA 92626 (US). WALLACE, George; Ten Brentano Drive, Coto de Caza, CA 92679 (US). GREFF, Richard, J.; 2891 Alton Drive, St. Pete Beach, FL 33706 (US).

(21) International Application Number: PCT/US00/40603

(22) International Filing Date: 7 August 2000 (07.08.2000)

(74) Agents: SWISS, Gerald, F. et al.; Burns, Doane, Swecker & Mathis, LLP, P.O. Box 1404, Alexandria, VA 22313 (US).

(25) Filing Language: English

(26) Publication Language: English

(81) Designated States (*national*): CA, JP.

(30) Priority Data:  
09/387,274 31 August 1999 (31.08.1999) US

(84) Designated States (*regional*): European patent (AT, BE, CH, CY, DE, DK, ES, FI, FR, GB, GR, IE, IT, LU, MC, NL, PT, SE).

(71) Applicant: MICRO THERAPEUTICS, INC.  
[US/US]; 2 Goodyear, Irvine, CA 92618 (US).

**Published:**

- With international search report.
- Before the expiration of the time limit for amending the claims and to be republished in the event of receipt of amendments.

(72) Inventors: CRAGG, Andrew, H.; 4502 Edina Boulevard, Edina, MN 55424 (US). WALKER, Blair, D.; 601 Baracuda, San Clemente, CA 92673 (US). PERL, John, II; Three Wenden Court, Bratenahl, OH 44108 (US). JONES, Michael; 34441 Camino El Molino, Capistrano Beach, CA 92624 (US). GREENE, George, Robert; 3019 Java Road,

For two-letter codes and other abbreviations, refer to the "Guidance Notes on Codes and Abbreviations" appearing at the beginning of each regular issue of the PCT Gazette.

(54) Title: CONTROLLED INJECTION OF LIQUID EMBOLIC COMPOSITION

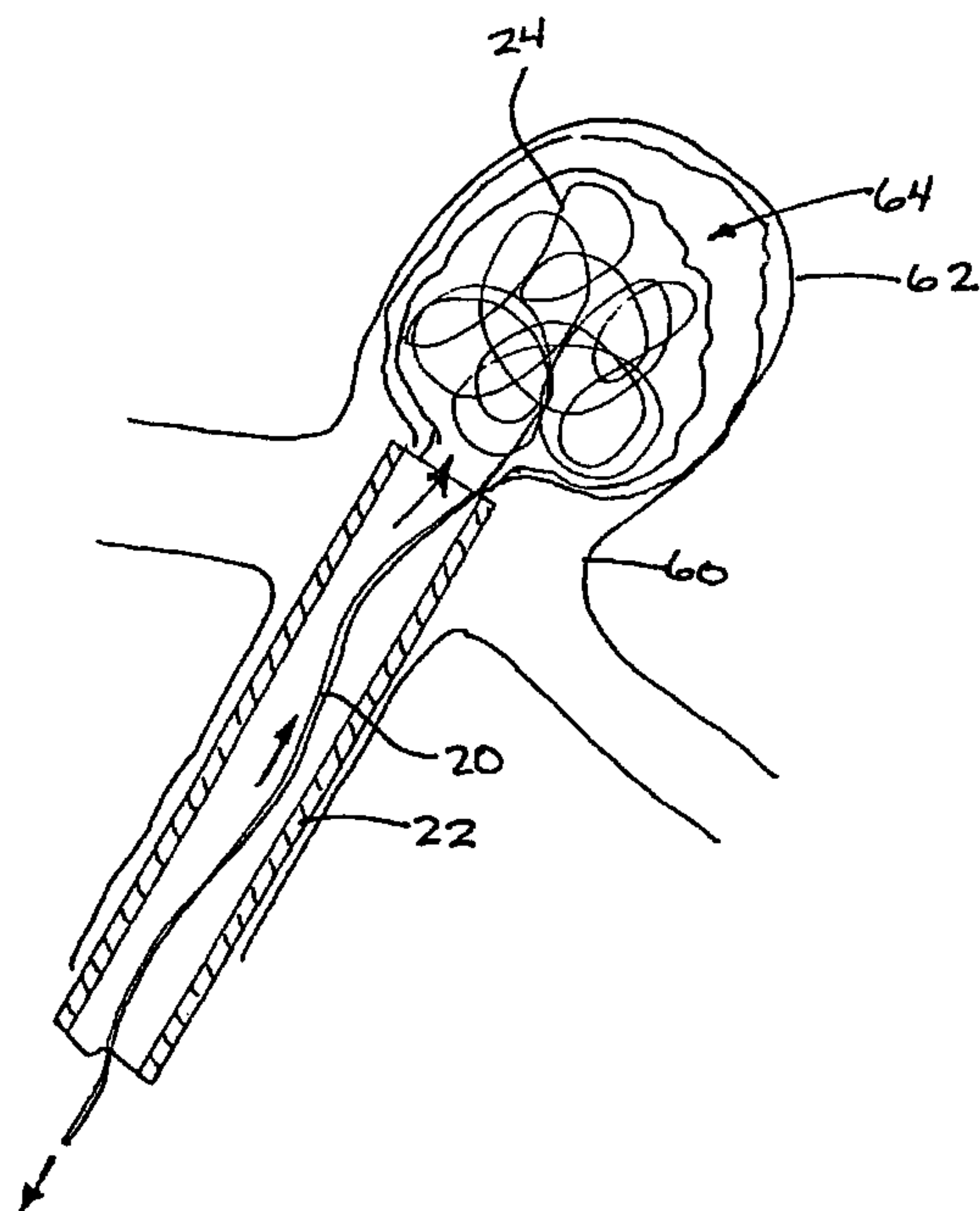

(57) Abstract: A liquid embolic delivery system is provided for trapping an injected liquid embolic composition to prevent the liquid embolic from solidifying or otherwise passing outside of an embolization area. The delivery system includes a catheter for delivery of a liquid embolic composition and a containment member positioned at a distal end of the catheter which is shaped to trap the liquid embolic composition delivered through the lumen of the catheter. The containment member is formed as a brush, nest, sponge, swab, flexible sack, or other shape into and around which the liquid embolic composition is injected. The liquid embolic composition is trapped or meshes with the containment member during solidification containing the liquid embolic and preventing the embolic composition from passing into the blood stream.

WO 01/15608 A1

## CONTROLLED INJECTION OF LIQUID EMBOLIC COMPOSITION

**BACKGROUND OF THE INVENTION****Field Of The Invention**

5       The invention relates to a device for controlling injection of a liquid embolic composition into a patient, and more particularly, to a device for containment and restraint of a liquid embolic composition during and after solidification. The device for controlling injection may be incorporated in a catheter system used for delivery of the embolic composition in a controlled  
10       manner.

**State Of The Art**

      In many clinical situations it is desirable to selectively occlude blood vessels for a variety of purposes, such as, the control or prevention of bleeding, the prevention of blood supply to tumors, treatment of arterial venous  
15       malformations (AVMs), and the blocking of blood flow within an aneurysm. Embolization of blood vessels has been performed by employing certain polymer compositions, particulates, and/or sclerosing material including silicone balloons, metallic coils, PVA particles, gelatin, and the like, to selectively block blood flow  
20       in the blood vessels. However, these embolization procedures have certain drawbacks.

      Intracranial aneurysms are abnormal blood filled dilations of a blood vessel wall which may rupture causing significant bleeding and damage to surrounding brain tissue or death. Traditionally, intracranial aneurysms have been surgically  
25       clipped to reduce the risk of rupture by placing a metal clip around the neck of the

-2-

aneurysm to cut off and prevent further blood flow to the aneurysm. However, many aneurysms cannot be treated surgically because of either the location and configuration of the aneurysm or because the condition of the patient does not permit cranial surgery.

5           When aneurysms cannot be treated surgically or when surgery is considered to be too risky or invasive, aneurysms may be treated endovascularly with coils. The coils are placed in the aneurysm by extending a catheter endovascularly to the site of the aneurysm and passing single or often multiple metallic coils such as platinum, stainless steel, or tungsten coils through the  
10 catheter into the aneurysm. The coils placed within the aneurysm create a thrombus which occludes the aneurysm and prevents further blood flow to the aneurysm. The treatment of intracranial aneurysms with coils isolates the aneurysm from arterial circulation, helping to guard against rupture and further growth of the aneurysm. However, the use of metallic coils to treat intracranial  
15 aneurysms may not be a permanent solution because the blood clot around the coils may lyse or dissolve due to the dynamic nature of the blood clotting function. Once a clot formed around the coils in an aneurysm lyses, the coil can no longer perform its function of occluding the aneurysm. In addition, the coils may become dislodged, move from the aneurysm, and enter the patient's blood stream causing  
20 blockages at other locations within the vascular system. Coils can also form a loop extending into the blood stream which generates undesirable embolisms downstream.

          Another drawback associated with the use of coils to occlude an aneurysm is that the coils are known to compact over time leaving cavities for subsequent  
25 aneurysm growth. In addition, if a subsequent surgical clipping procedure is warranted, it can be difficult to place the clip over the coil mass.

          Other procedures for treating aneurysms include occluding the aneurysm with a silicone balloon or filling the aneurysm with particulate material.

-3-

Aneurysms having large necks are not easily treated by either surgical clipping or by coils because the aneurysm neck may have a shape which cannot be completely clipped surgically and the coils may tend to become dislodged from the aneurysm when the neck is particularly large.

5           One minimally invasive procedure for treating intracranial aneurysms which addresses the problems with the surgical clipping and coil techniques involves the endovascular injection of a liquid embolic composition which solidifies in the aneurysm to occlude the aneurysm. Typically, liquid embolic compositions include a water insoluble, biocompatible, non-biodegradable  
10 polymer, dissolved in a biocompatible solvent. Once the liquid embolic composition is injected into the aneurysm, the biocompatible solvent dissipates into the blood and the polymer solidifies to occlude the blood flow through the aneurysm. These liquid embolic compositions preferably include a radiopaque material which allows the physician to view the embolization procedure by  
15 fluoroscopy.

Prior to delivery of the liquid embolic composition to the aneurysm, the aneurysm and delivery device are preferably positioned so that the liquid embolic composition will be delivered by gravity into the aneurysm and will solidify and remain in the aneurysm. This means that the patient position is often manipulated  
20 to position the aneurysm with the aneurysm neck pointing up. As the embolic composition is delivered to the aneurysm, the solvent dissipates from the polymer material and is removed in the blood stream causing the polymer material within the aneurysm to solidify.

Depending on the rate at which the liquid embolic material is injected into  
25 the blood vessel and the amount of blood flow present, the polymer may remain in liquid form for a period of time while the solvent dissipates into the blood stream. In addition, the solvent concentration at the point of injection may increase to a point where small strings of unsolidified polymer material may separate from the

-4-

polymer mass and be carried away in the blood stream where the polymer can occlude an undesired vascular location.

Accordingly, it would be desirable to provide a device or method for controlling the solidification of the polymer material during injection so that an aneurysm which is in a non-gravity dependent position can be filled without causing the liquid embolic composition to pass out of the aneurysm into the blood stream. It would also be desirable to prevent polymer strings from being carried away in the blood stream.

#### 10 SUMMARY OF THE INVENTION

The present invention relates to a containment member for trapping an injected liquid embolic composition to prevent the liquid embolic from solidifying outside of an embolization area.

In accordance with one aspect of the present invention, a liquid embolic delivery system includes a catheter having a lumen for delivery of a liquid embolic composition to a cavity, a containment member positioned at a distal end of the catheter, and a detachment mechanism for completely detaching the containment member from the catheter after solidification of the liquid embolic composition to allow separation of the catheter from a mass of solidified embolic composition.

20 The containment member is shaped to trap the liquid embolic composition delivered through the lumen of the catheter.

In accordance with an additional aspect of the present invention, a method of containing a liquid embolic composition at an embolization site within a body includes the steps of delivering a liquid embolic composition to an embolization site within a body with a catheter, containing the liquid embolic composition during solidification with a containment member, and detaching the containment member from the catheter after solidification of the liquid embolic composition to release the catheter from a mass of solidified embolic composition.

25

-5-

**BRIEF DESCRIPTION OF THE DRAWINGS**

The invention will now be described in greater detail with reference to the preferred embodiments illustrated in the accompanying drawings, in which like elements bear like reference numerals, and wherein:

5

FIG. 1 is a side cross sectional view of a first embodiment of a liquid embolic delivery system with a multifilament brush in a retracted position;

FIG. 2 is a side cross sectional view of the delivery system of FIG. 1 with the multifilament brush in the extended position;

10

FIG. 3 is a side cross sectional view of a delivery system according to a second embodiment prior to formation of a nest;

FIG. 4 is a side cross sectional view of the delivery system of FIG. 3 with a nest formed;

15

FIG. 5 is a side cross sectional view of a delivery system according to a third embodiment with a sponge in a retracted position;

FIG. 6 is a side cross sectional view of the delivery system of FIG. 5 with the sponge in the extended position;

FIG. 7 is a side cross sectional view of a delivery system according to a fourth embodiment with a swab in a retracted position;

20

FIG. 8 is a side cross sectional view of the delivery system of FIG. 7 with the swab in the extended position;

FIG. 9 is a side cross sectional view of a delivery system according to a fifth embodiment with a magnetic member in a retracted position;

25

FIG. 10 is a side cross sectional view of the delivery system of FIG. 9 with the magnetic member in the extended position;

FIG. 11 is a side cross sectional view of an aneurysm being treated by the delivery system of FIGS. 3 and 4;

-6-

FIG. 12 is a side cross sectional view of an aneurysm with a mass of liquid embolic material filling the aneurysm;

FIG. 13 is a side cross sectional view of an aneurysm after the delivery system has been detached from the mass of liquid embolic material;

5 FIG. 14 is a side cross sectional view of a delivery system according to a sixth embodiment including a flexible sack in a retracted position;

FIG. 15 is a side cross sectional view of the delivery system of FIG. 14 with the flexible sack in the extended position;

10 FIG. 16 is a side cross sectional view of the delivery system of FIG. 14 in which liquid embolic composition has solidified within the flexible sack;

FIG. 17 is a side cross sectional view of an aneurysm with an aneurysm neck flow disruption system;

FIG. 18 is a side cross sectional view of an aneurysm with an alternative embodiment of an aneurysm neck flow disruption system;

15 FIG. 19 is a cross sectional view taken along line A-A of FIG. 18; and  
FIG. 20 is a cross sectional view taken along line B-B of FIG. 18.

### **DETAILED DESCRIPTION OF THE PREFERRED EMBODIMENTS**

The liquid embolic delivery system includes a catheter having a lumen through which liquid embolic composition is delivered to an embolization site within the body. A containment member, such a nidus or a flexible sack is positioned at the distal end of the catheter and, the liquid embolic composition is injected into the containment member. The liquid embolic composition is trapped or meshes with the containment member during solidification containing the liquid embolic and preventing the liquid embolic composition from passing into the blood stream. The preferred embodiments of the containment member for use with the delivery system will be discussed below with respect to the various figures.

20  
25



-7-

Prior to discussing the present invention in further detail, the following terms are defined:

The term "liquid embolic composition" refers to a fluid composition that is injected at an embolization site and solidifies to fully or partially occlude the embolization site.

The term "embolizing" or "embolization" refers to a process wherein a fluid composition is injected into a blood vessel or tissue which, in the case of, for example, aneurysms fills or plugs the aneurysm sack and/or encourages clot formation so that blood flow into the aneurysm and pressure in the aneurysm ceases, and in the case of arterial venous malformations (AVMs) and arterial venous fistula (AVFs) forms a plug or clot to control/reroute blood flow to permit proper tissue perfusion. Embolization may be used for preventing or controlling bleeding due to lesions (e.g., organ bleeding, gastrointestinal bleeding, vascular bleeding, as well as bleeding associated with an aneurysm). In addition, embolization can be used to ablate diseased tissue (e.g., tumors, etc.) by cutting off the blood supply.

The liquid embolic composition for use in the present invention may be any biocompatible composition which solidifies within the body, for example a biocompatible polymer combined with a suitable biocompatible solvent such as ethanol, dimethylsulfoxide (DMSO), ethyl lactate, acetone, and the like. Examples of embolizing compositions are described in U.S. Patent No. 5,667,767, which issued September 16, 1997, U.S. Patent No. 5,580,568, which issued December 3, 1996, and U.S. Patent Application Serial No. 08/688,050 each of which are incorporated herein by reference in their entirety. Other liquid embolic compositions would include hydrogels such as, polyhema, and other polyacrylatecs, cellulosecs, and other natural polymers and prepolymers, cyanoacrylatecs, urethane, and silicones.

-8-

According to one preferred embodiment of the invention in which the solvent used is DMSO, the delivery system elements which may come into contact with the solvent are DMSO compatible. Examples of DMSO compatible catheter materials include polyolefins, such as polyethylene or polypropylene; fluoropolymers, such as PTFE and ETFE, and silicones.

The liquid embolic delivery system as shown in FIGS. 1 and 2 includes an elongated flexible catheter 10 and a containment brush 12 disposed within the catheter. The catheter 10 may be an over the wire catheter, a flow directed catheter, or any other type of catheter capable of delivering the liquid embolic composition to the embolization site. The brush 12 includes an elongated flexible shaft 14 which extends through the lumen of the catheter 10 for manipulation of the brush from the proximal end of the catheter which extends outside the patient's body. The brush 12 includes a plurality of filaments 16 extending substantially radially from a distal end of the shaft 14.

In use, the catheter 10 is delivered to an embolization site with the brush 12 in the retracted position, shown in FIG. 1, in which the brush is positioned fully or substantially within the lumen. The shaft 14 is then moved distally within the catheter 10 to extend the brush 12 from the distal end of the catheter. The brush 12 is positioned such that the liquid embolic composition exiting the lumen of the catheter 10 will become trapped by the brush. Preferably, the brush is positioned about 0 to 5 mm, more preferably about 1 to 4 mm from the distal end of the catheter with the exact position depending on the particular embolization site and procedure being performed.

Once the brush 12 has been positioned the liquid embolic composition is then injected through the catheter 10 either through the same lumen in which the shaft 14 of the brush 12 extends or through a second parallel lumen of the catheter. As the liquid embolic composition is delivered down the catheter the liquid which exits the distal end of the catheter is injected into the filaments 16 of the brush 12.

-9-

The solvent begins to dissipate from the liquid embolic composition and the polymer material precipitates and meshes with the bristles of the brush.

Subsequent injections of liquid embolic material increase the mass of solidified embolic material surrounding the brush at the embolization site. Injection of the liquid embolic composition continues until the embolization site is completely embolized. The brush 12 acts to contain and trap the precipitating material and prevent the effects of gravity and blood flow from causing the polymer material to be carried away from the embolization site.

After the liquid embolic composition has been delivered through the catheter 10 and has formed a solid mass around the brush 12, the mass is detached from the catheter and the brush shaft 14 by a detachment mechanism, such as a mechanical, electrical, or chemical detachment system as discussed below.

Although the brush 12 has been described as attached to an elongated flexible shaft 14 which extends through the lumen of the catheter 10, the brush may also be connected by a mounting member, such as a short shaft, directly to the distal end of the catheter. When the brush 12 is connected directly to the end of the catheter 10 the catheter and brush may be introduced together as a single unit through a separate introducing catheter of a larger diameter than the catheter 10. After delivery of liquid embolic composition the brush 12 may be detached from the catheter 10 or the entire distal end of the catheter may be detachable.

The filaments 16 of the brush 12 are preferably flexible members formed of a material such as nylon, polyethylene, polypropylene, polyester, PTFE, Dacron, and the like. The filaments are preferably soft, flexible, bio-compatible, and DMSO compatible. The filament size may vary depending on the application, however, one example of a suitable filament has a diameter of about 75 to about 500 microns, preferably about 150 to about 250 microns, and a length depending on an inner diameter of the vascular site of about 1 to about 30 mm, preferably about 2 to about 10 mm.

-10-

FIGS. 3 and 4 illustrate an alternative embodiment of the liquid embolic delivery system in which a wire 20 is delivered through the lumen of a catheter 22 when the wire 20 exits the distal end of the catheter 22 the wire forms into a nest configuration at the embolization site. The wire 20 is preformed with a curvature which creates the nest 24 when the wire is delivered out of the distal end of the catheter 22. The shape of the nest 24 generally conforms to the shape of the embolization site, for example, when treating an aneurysm the nest 24 will conform to the shape of the aneurysm. The liquid embolic composition is subsequently delivered through the catheter lumen and is trapped by and precipitates on the wire nest 24. As in the embodiment described above, after embolization is complete, the solidified mass of embolic material and the wire nest 24 are detached from the catheter.

The wire 20 may be preformed to cause the nest 24 to take on a particular predetermined shape. Examples of nest shapes include the randomly curving wire shape shown in FIG. 4 and a coil or spiral shape. The wire 20 may be formed of a biocompatible material, such as, stainless steel, platinum, Nitinol, gold, tungsten, and the like. In addition, it may be desirable to form the wire 20 from a shape memory material, such as Nitinol.

Another alternative embodiment of the invention including a sponge like member 30 and a catheter 32 is illustrated in FIGS. 5 and 6. As shown in FIG. 5, the sponge 30 is compressed within the lumen of the catheter 32 during delivery of the catheter to the embolization site. Once the distal tip of the catheter 32 is located at or near the embolization site, the sponge 30 is deployed from the catheter by a plunger or rod 34 which extends through the catheter lumen 32 and connects to the sponge 30. Once the sponge 30 has been deployed from the catheter 32 the sponge expands to the configuration shown in FIG. 6. The expanded sponge 30 includes a plurality of large holes 36 and smaller pores into which the liquid embolic composition is injected.

-11-

As in the embodiment of FIGS. 1 and 2, the sponge 30 of FIGS. 5 and 6 may be fixed to the end of the catheter 32 instead of to the plunger 34 and the entire catheter and sponge system may be delivered to the embolization site through an introducing catheter. The liquid embolic composition may then be delivered by the catheter 32 to an exterior or an interior of the sponge. Once an embolic mass has formed around the sponge 30 by injection of the liquid embolic composition through the catheter lumen, the embolic mass is detached from the catheter 32 and remains within the embolization site after the catheter has been removed. The detachment of the solidified embolic mass from the catheter 32 and the rod 34 is performed by mechanical, electrical, or chemical detachment as will be described further below.

The sponge member 30 according to the embodiment of FIGS. 5 and 6 is formed of a biocompatible, open cell, compressible material having a high porosity, such as polyethylene sponge, polypropylene sponge, polyurethane sponge, PVA, fluoropolymer, and the like. The size and shape of the sponge 30 will be modified to properly fit within the particular embolization site. The sponge material is preferably a biocompatible, DMSO compatible, non-toxic, soft, material which fully fills the aneurysm. An expansion ratio of the sponge is preferably about 5:1 to 20:1, more preferably about 10:1

FIGS. 7 and 8 relate to a further alternative embodiment of the invention in which the containment member for trapping the liquid embolic composition is a swab shaped member 40 of a filamentous material. The swab shaped member 40 may be compressed within and deployed from the lumen of a catheter 42 by a pusher or rod 44 or can be permanently affixed to the distal end of the catheter and inserted through an introducing catheter. The liquid embolic composition which is delivered through the catheter 42 is trapped in and around the swab shaped member 40. Additional embolic composition solidifies in shells around the core provided by the swab shaped member 40. Appropriate materials for the swab

-12-

shaped member 40 include biocompatible materials, such as polyester, PTFE, silk, Dacron, polyethylene, nylon, fluoropolymer, cotton, and the like. The shape and size of the swab 40 may be modified to correspond with a particular shape and size of an embolization site.

5 A further embodiment of the liquid embolic delivery system, as shown in FIGS. 9 and 10, includes a node 50, such as an electrically charged member or a magnet, which attracts the liquid embolic composition delivered through the lumen of a catheter 52. The node 50 can be fixed on the end of the catheter 52 or preferably is movable from a retracted position, shown in FIG. 9, to an extended  
10 position, shown in FIG. 10, by a rod 54 extending through the catheter lumen. The polymer composition preferably includes magnetic particles which are attracted to the node. The node 50 is positioned generally in a center of an embolization site and the liquid embolic agent solidifies in shells around the node.

FIGS. 11 - 13 illustrate a method of treating an aneurysm with the liquid  
15 embolic delivery system having the wire nest 54 which has been described above with respect to FIGS. 3 and 4. As shown in FIG. 11, the catheter 22 is positioned at or near a neck 60 of an aneurysm 62 and the wire 20 is passed through the lumen of the catheter 22 to form a wire nest 24 within the aneurysm. The liquid embolic material is then injected through the lumen of the catheter 22 and is  
20 trapped by the wire nest 24 during solidification. Injection of the liquid embolic material continues until the aneurysm 62 is completely or substantially filled with an embolic mass 64 as illustrated in FIG. 12. The catheter is then detached from the solidified mass 64 of liquid embolic material within the aneurysm by chemical, mechanical, or electrical detachment means. For example, the mass 64 of embolic  
25 composition may be detached by holding the catheter 22 stationary while pulling the wire 20 proximally within the catheter lumen to break the wire at a location where the wire enters the liquid embolic mass. The catheter 22 and the wire 20 are then removed from the embolization site leaving the liquid embolic mass 64

-13-

and the wire nest 24 embedded within the mass in the aneurysm. The wire 20 which has been broken as described above may also be used as a pusher to separate the embolic mass 64 from the catheter 22. This method of treating an aneurysm may also be used for other embolization treatments.

5           The liquid embolic delivery system according to the present invention may be configured so that injection of liquid embolic composition forms as consecutive shells over a beginning kernel as the embolic mass increases in size. Alternatively, the liquid embolic may be injected from a center of the containment member so that an outer skin is created first and additional embolic is added inside  
10 the mass causing the outer skin to expand.

          FIGS. 14 - 16 illustrate a liquid embolic delivery system including a flexible sack 70 affixed to a distal end of a catheter 72. The edges 78 of the flexible sack 70 are affixed in a known manner to an exterior of the catheter distal tip such that the flexible sack surrounds the catheter outlet. The catheter 72  
15 having the flexible sack 70 affixed to the distal end are delivered to an embolization site through an introducer catheter 76 having a somewhat larger diameter than the catheter 72. Once the flexible sack 70 is placed within the embolization site such as within an aneurysm, a liquid embolic composition is injected through the catheter lumen.

20           The flexible sack 70 is formed of a membrane or woven material which is substantially impermeable to the precipitate of the liquid embolic composition while being permeable to the solvent to allow the solvent to dissipate from the liquid embolic material injected into the flexible sack. Examples of biocompatible materials which may be used to form the flexible sack 70 include polyester, PTFE,  
25 urethane, Dacron, nylon, polyethylene, fluoropolymers, silicone, and the like. According to one embodiment, the flexible sack is a mesh bag having a structure which allows the diameter of the bag to increase as the embolic composition is injected. The mesh material may be non-elastic or may be elastic acting like a

-14-

balloon. The mesh allows the solvent to dissipate out of the bag while the structure of the bag prevents fingers or strands of embolic material from passing out of the embolization area. The flexible sack 70 is detachable from the distal end of the catheter 72 once the embolization is complete so that the catheter can be  
5 removed from the embolization site.

The method of detachment of any one of the containment members described above from the catheter of the present invention may be either mechanical, electrical, or chemical. One example of a mechanical method of detachment involves forcibly detaching the mass of embolic material and the  
10 containment member from the distal tip of the catheter such as by use of a plunger member extending through the lumen of the catheter. Alternatively, an outer catheter sleeve may be used to strip a mass from a distal tip of the catheter. Mechanical detachment can also be performed by various interlocking, pushing, twisting, and locking motions.

15 Electrical detachment may be performed by providing a weakened section at a junction between the containment member and the catheter which is easily vaporized by application an electric current. For example, a 9V electric power source may apply a current of about 0.3 mA for detachment. One example of an electrical detachment mechanism is described in U.S. Patent No. 5,928,226, which  
20 is incorporated herein by reference.

Finally, with a chemical detachment mechanism, a dissolvable detachment section is included in the delivery system between the catheter and the containment member or at the distal end of the catheter. The dissolvable detachment section is dissolved, softened, swollen, degraded, or otherwise changed by the injection of a  
25 biocompatible chemical through the catheter. Some examples of chemical detachment systems include dissolvable detachment sections, such as a polymer section which is dissolved by DMSO, a nylon section which is dissolved by a



-15-

fluorinated hydrocarbon, or sections which are dissolved by saline or any of the other biocompatible solvents discussed above.

FIGS. 17-20 illustrate a liquid embolic delivery system which disturbs the blood flow into and out of the aneurysm to improve control over injection of the liquid embolic composition. The disturbance of blood flow into and out of the aneurysm through the aneurysm neck creates a low turbulence or "peaceful" fluid environment within the aneurysm which allows improved filling of the aneurysm with the embolic material.

As shown on FIG. 17, a delivery system 100 is placed at an embolization site such as an aneurysm 90 having an aneurysm neck 92. The delivery system has two lumens including an inner lumen 102 for delivery of the liquid embolic composition and an outer lumen 104 for injection of a fluid such as saline which is used to disrupt blood flow at the aneurysm neck 92. The delivery system 100 may be formed from an inner catheter 106 and an outer catheter 108 concentrically surrounding the inner catheter and having a plurality of side ports 110 which can be positioned at the aneurysm neck 92. A distal end of the outer catheter 108 forms a fluid tight seal with an exterior of the inner catheter 106. This distal end of the outer catheter 108 may be permanently bonded to the inner catheter or may be slideable over the inner catheter with or without a valve member. The inner and outer catheters 106, 108 may be provided with radiopaque markers 112 for visualization of the position of the inner and outer catheters. Alternatively, a radiopaque marker may be sandwiched between the two tubes at a fuse joint at the distal end of the outer catheter 108.

The side holes 110 are preferably spaced around the outer catheter 108 and are positioned within an area of a relatively short axial length. In use, the delivery system 100 is guided to an aneurysm over a guidewire using the inner catheter lumen 102 as a guidewire lumen. The tip of the inner lumen is located within the dome of the aneurysm and the side holes 110 are positioned near the aneurysm

-16-

neck 92. The guidewire is then removed and the disruption fluid is then injected through the outer catheter 108 and exits the side holes 110 of the delivery device. The disruption fluid can be any biocompatible fluid such as saline, contrast medium, or mixtures thereof. The flow of the disruption fluid is visualized and  
5 adjusted so that optimum disruption of blood flow at the aneurysm neck occurs. The liquid embolic material is then injected through the lumen 102 of the center catheter 106 until the aneurysm 90 has been filled and the embolic composition is solidified.

According to one embodiment of the present invention, the inner catheter  
10 106 is slideable with respect to the outer catheter 108 to allow adjustment of the distance between the distal tip where the liquid embolic composition is injected and the disruption side holes 110. The ability to adjust the delivery device 100 in this manner is useful because aneurysms vary in size. A valve at the distal end of the outer catheter 108 can allow the outer catheter to slide easily over the inner  
15 catheter in an axial direction without the leakage of fluid.

FIGS. 18-20 illustrate an alternative embodiment of a delivery system 120 which allows a pattern of the disruption flow to be controlled. Because the necks 92 of many aneurysms 90 have non-circular or elliptical cross sections, it may be desirable to vary the flow rate of the aneurysm neck disrupting fluid out of  
20 different side holes around the circumference of the delivery system. In other words, it may be desirable to increase the disruption fluid flow at side holes which are oriented in a direction of a major axis of the elliptical neck while decreasing the flow at side holes which are oriented in the direction of the minor axis of the elliptical neck.

25 FIG. 18 illustrates an aneurysm 90 having an elliptical aneurysm neck 92 and a delivery system 120 for delivery of liquid embolic composition and disruption fluid to the aneurysm. The delivery system 120 includes an elongated catheter 122 with a central lumen 124 and a plurality of surrounding lumens 126.

-17-

The surrounding lumens 126 are spaced around the central lumen 124 and each include a side port 128 for delivery of the disruption fluid. FIG. 19 shows a cross section of the catheter 122 taken along line A-A illustrating the central lumen 124 and a plurality of surrounding lumens 126.

5           At a proximal end of the catheter 122 a fluid connection 130 is provided for connection of the central lumen to a source of the liquid embolic composition. A fluid connection 132 is also provided for connection of the plurality of surrounding lumens 126 to a source of disruption fluid. A manifold 134 and a plurality of valves are provided for controlling delivery of the disruption to the  
10 different surrounding lumens 126 at relatively variable velocities. The manifold 134 and valves provide a flow regulating means for delivery of the fluid which allows the fluid delivered from the different side ports 128 at the aneurysm neck 92 to be carefully controlled as illustrated in FIG. 20.

          According to a further embodiment of the liquid delivery having aneurysm  
15 neck disruption side flow, one or more rows of side holes may be provided. These rows of side holes may be positioned just inside and just outside the aneurysm neck to further disrupt the blood flow through the neck.

          While the invention has been described in detail with reference to the preferred embodiments thereof, it will be apparent to one skilled in the art that  
20 various changes and modifications can be made and equivalents employed, without departing from the present invention.

-18-

WHAT IS CLAIMED IS:

1. A liquid embolic delivery system comprising:  
a catheter having a lumen for delivery of a liquid embolic  
5 composition to a cavity;  
a containment member positioned at a distal end of the catheter, the  
containment member shaped to trap the liquid embolic composition delivered  
through the lumen of the catheter; and  
a detachment mechanism for completely detaching the containment  
10 member from the catheter after solidification of the liquid embolic composition to  
allow separation of the catheter from a mass of solidified embolic composition.
2. The liquid embolic delivery system according to claim 1, wherein  
the containment member is a flexible sack which fills with the liquid embolic  
composition.
- 15 3. The liquid embolic delivery system according to claim 2, wherein  
the flexible sack is positioned over a distal outlet of the lumen with a neck of the  
sack connected to the distal end of the catheter around an opening of the catheter  
lumen, the detachment mechanism detaching the flexible sack neck from the distal  
end of the catheter.
- 20 4. The liquid embolic delivery system according to claim 2, wherein  
the flexible sack is formed of a mesh material which allows solvent to pass through  
the sack, the mesh material containing the liquid embolic composition which has  
solidified.

-19-

5. The liquid embolic delivery system according to claim 2, wherein the flexible sack is formed as a resilient balloon over the distal end of the catheter.

6. The liquid embolic delivery system according to claim 1, wherein the containment member is a nidus extending from the distal end of the catheter and positioned to trap the liquid embolic composition as the liquid embolic composition solidifies.

7. The liquid embolic delivery system according to claim 6, wherein the nidus is formed from a wire which is delivered through the catheter lumen and forms a coil upon exiting the distal end of the lumen.

8. The liquid embolic delivery system according to claim 6, wherein the nidus is in the form of a wire brush.

9. The liquid embolic delivery system according to claim 6, wherein the nidus is in the form of a swab.

10. The liquid embolic delivery system according to claim 6, wherein the nidus is in the form of a sponge.

11. The liquid embolic delivery system according to claim 6, wherein the nidus is in the form of a flexible sack.

12. The liquid embolic delivery system according to claim 6, wherein the nidus is formed from a wire which is delivered through the catheter lumen and forms a randomly shaped nest upon exiting the distal end of the lumen.

-20-

13. The liquid embolic delivery system according to claim 1, wherein the detachment mechanism includes means for delivering an electrical charge to a point between the containment member and the catheter to detach the containment member from the catheter.

5 14. The liquid embolic delivery system according to claim 1, wherein the detachment mechanism includes a chemical detachment section between the containment member and the catheter which is dissolved by a chemical agent.

15. A method of containing a liquid embolic composition at an embolization site within a body comprising:  
10 delivering a liquid embolic composition to an embolization site within a body with a catheter;  
containing the liquid embolic composition during solidification with a containment member; and  
15 detaching the containment member from the catheter after solidification of the liquid embolic composition to release the catheter from a mass of solidified embolic composition.

16. The method according to claim 15, wherein the liquid embolic composition is contained by trapping embolic composition in a nidus during solidification.

20 17. The method according to claim 15, wherein the liquid embolic composition is contained by a flexible sack and solvent dissipates through the sack during solidification of the liquid embolic composition.

-21-

18. The method according to claim 15, wherein the containment member is positioned at the embolization site before delivery of the liquid embolic composition by moving the containment member out of a lumen of the catheter.

5 19. The method according to claim 15, wherein the containment member and the catheter are delivered to the embolization site through an introducing catheter.

FIG. 1

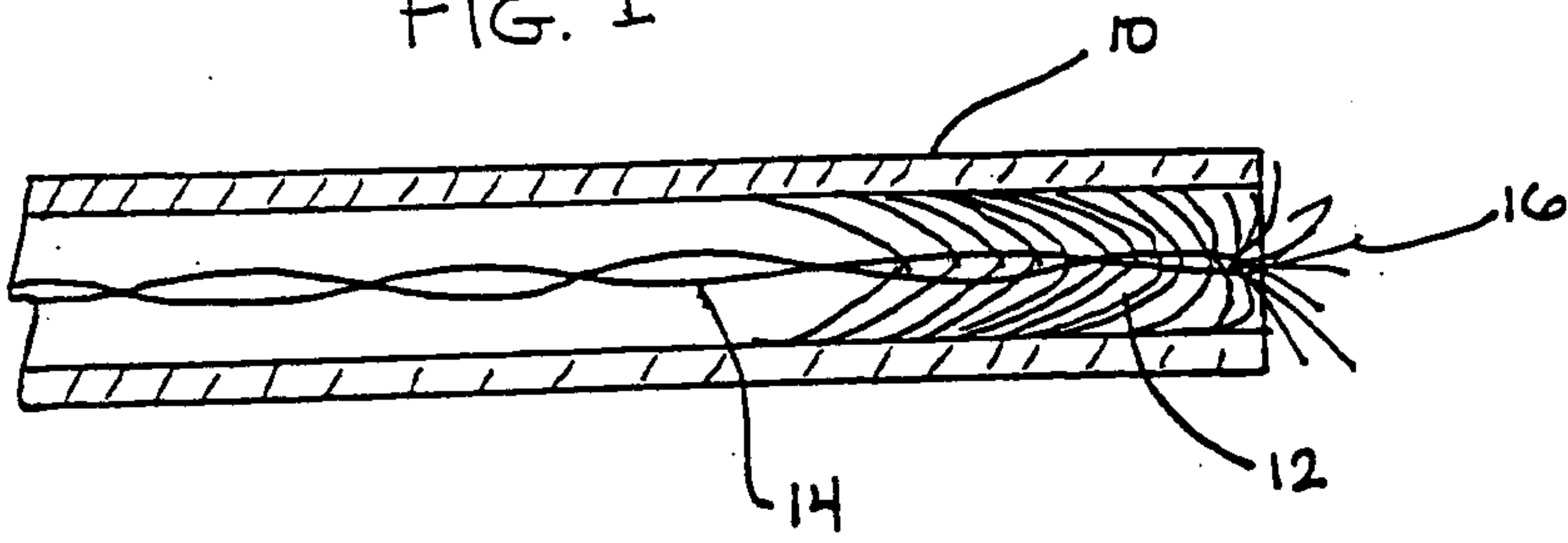

FIG. 2

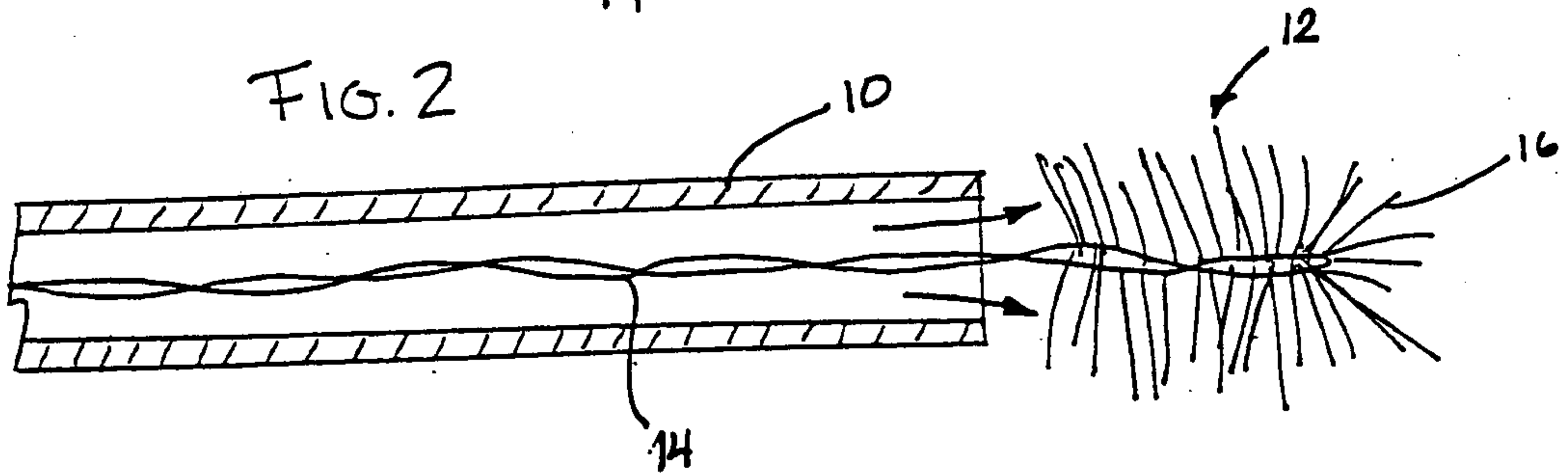

FIG. 3

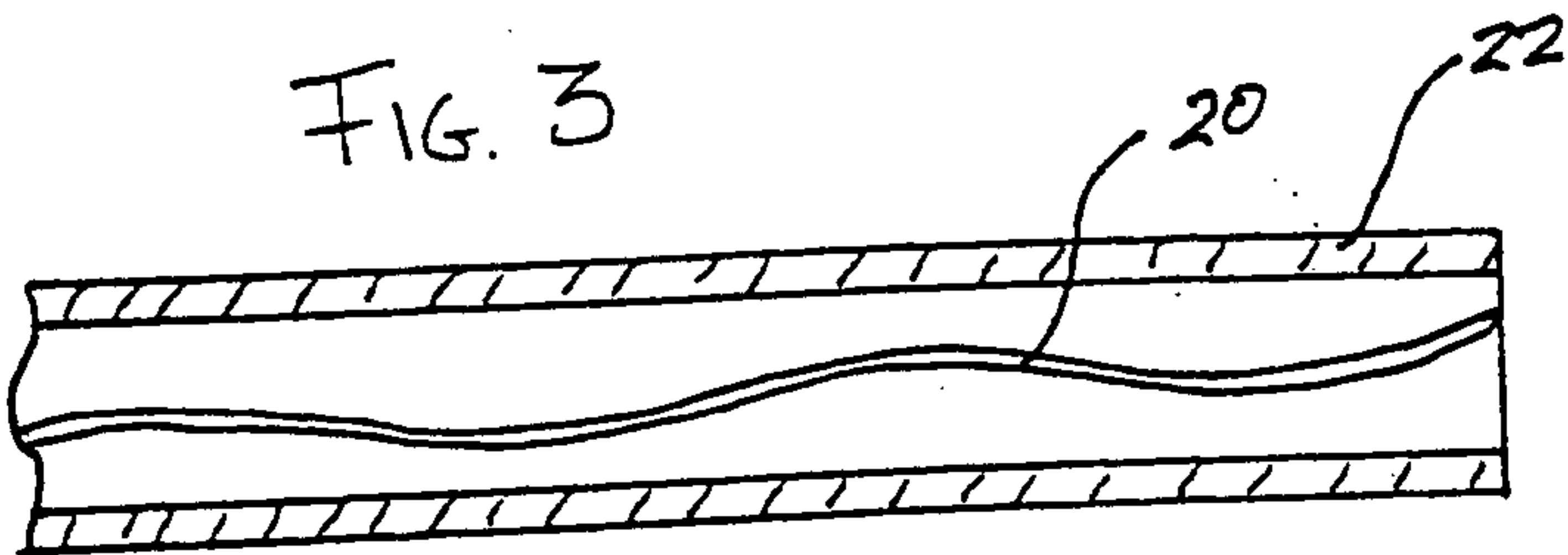
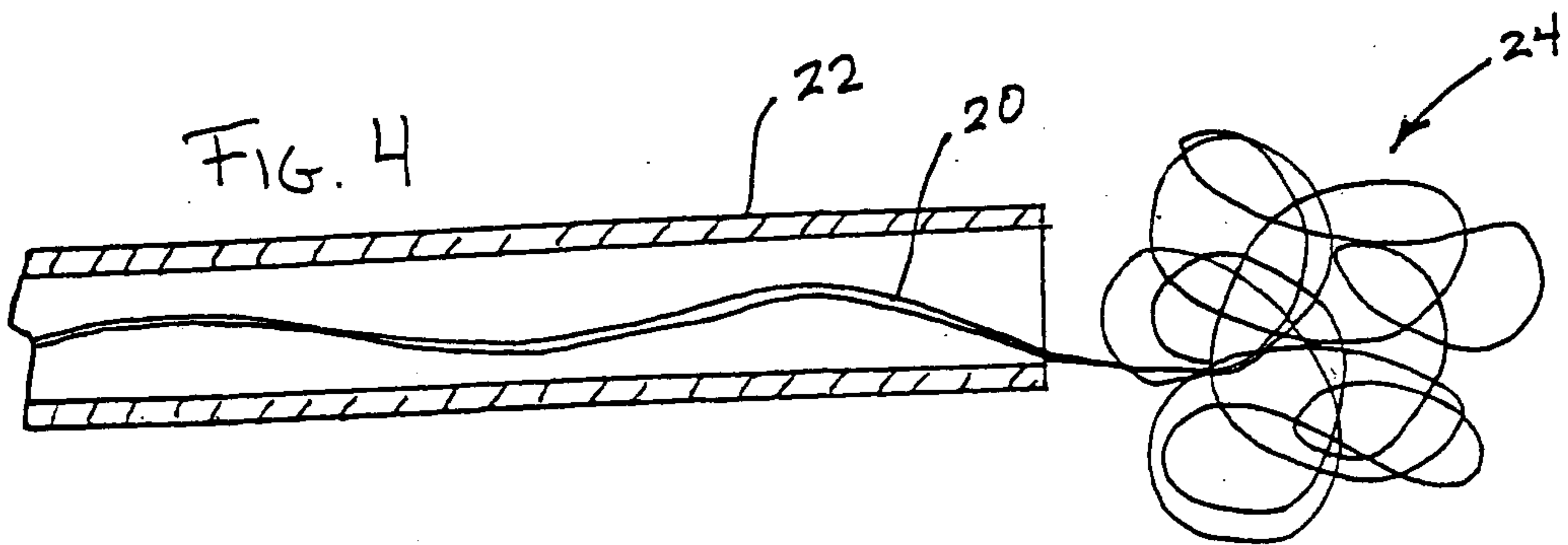

FIG. 4





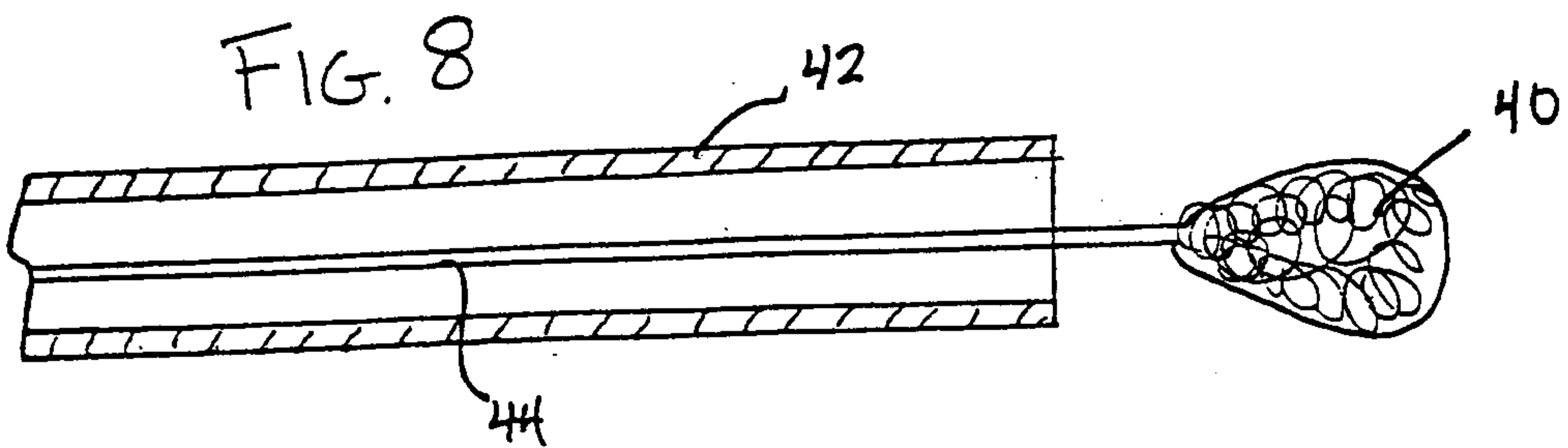
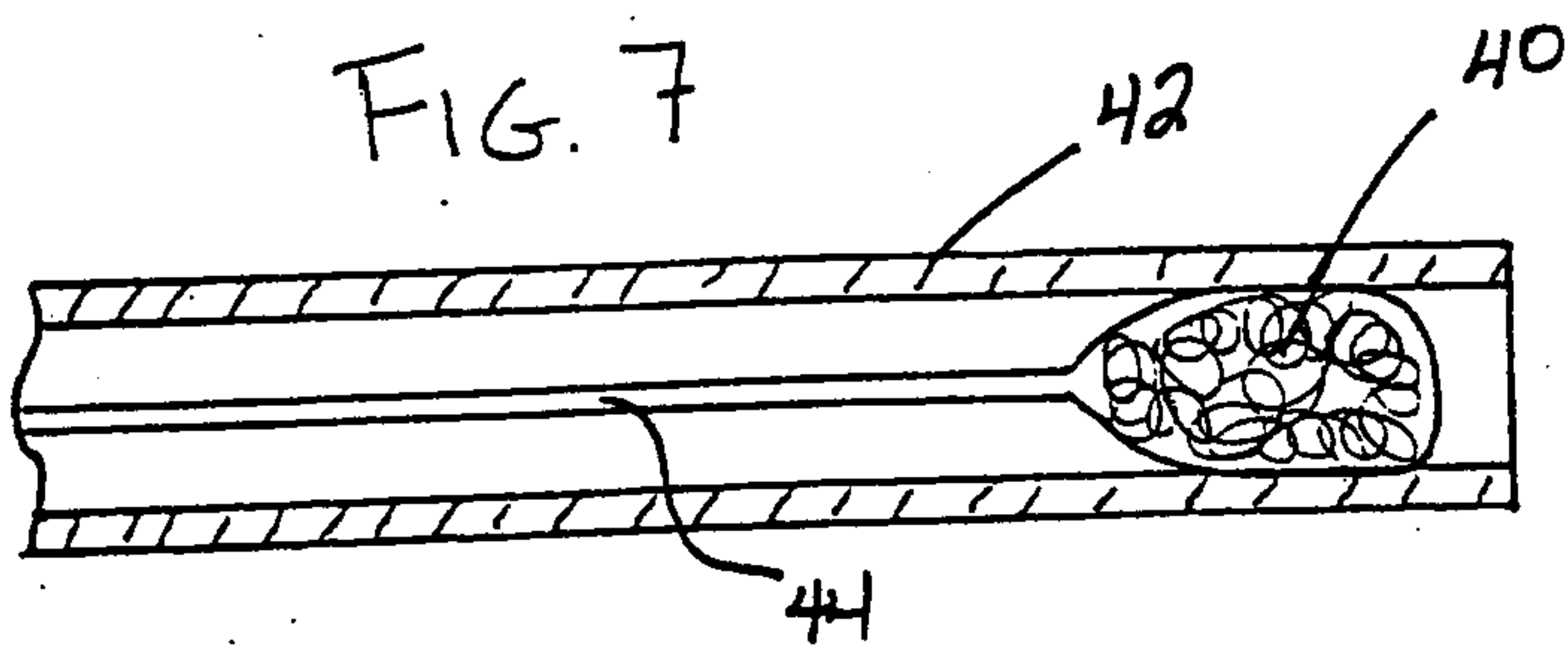
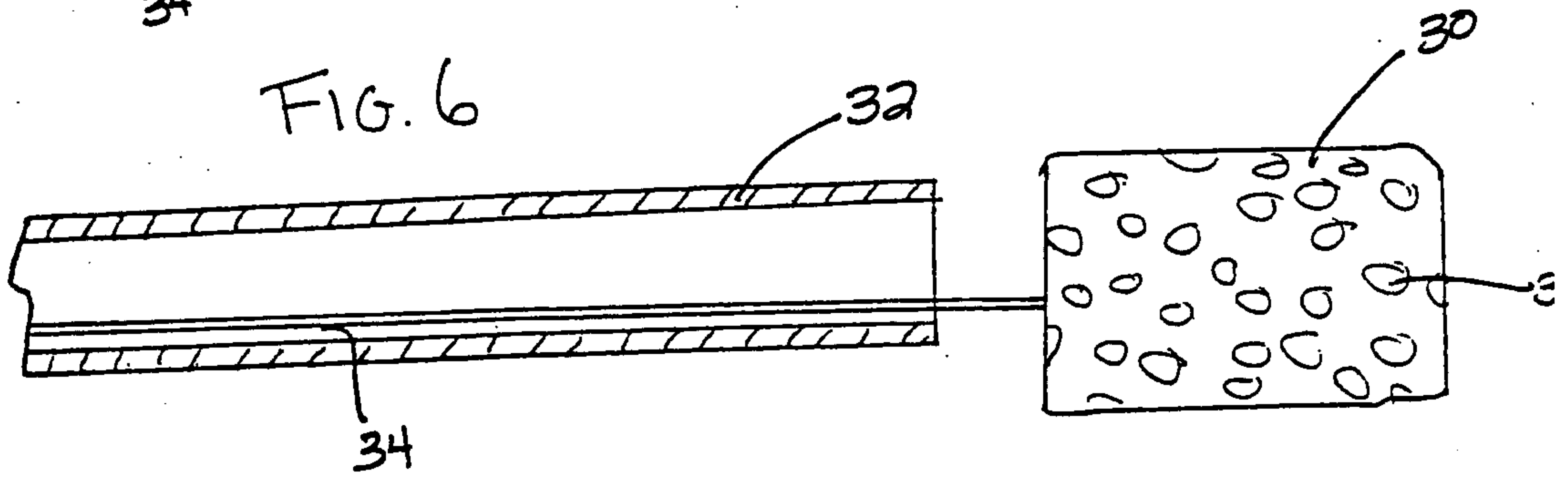
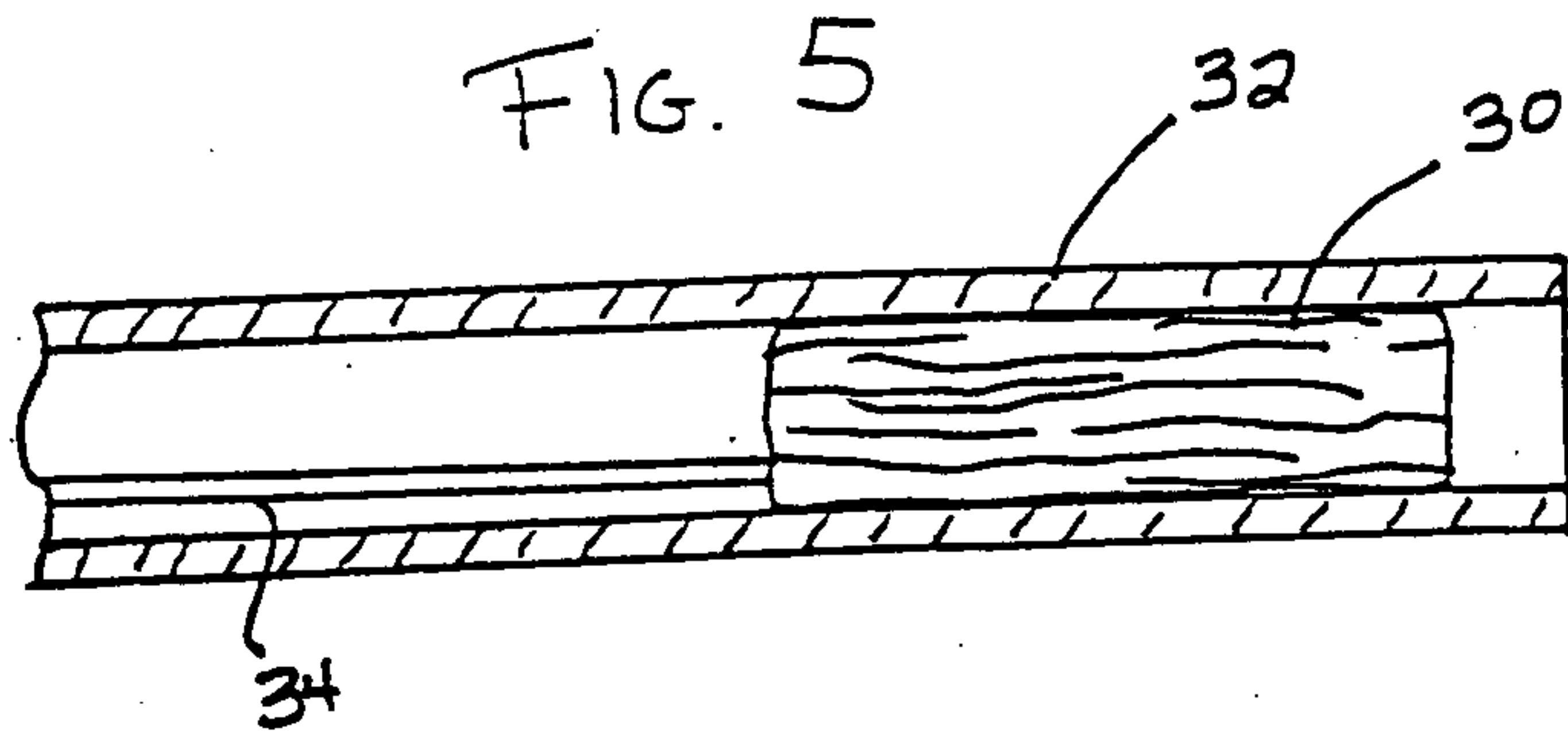

FIG. 9

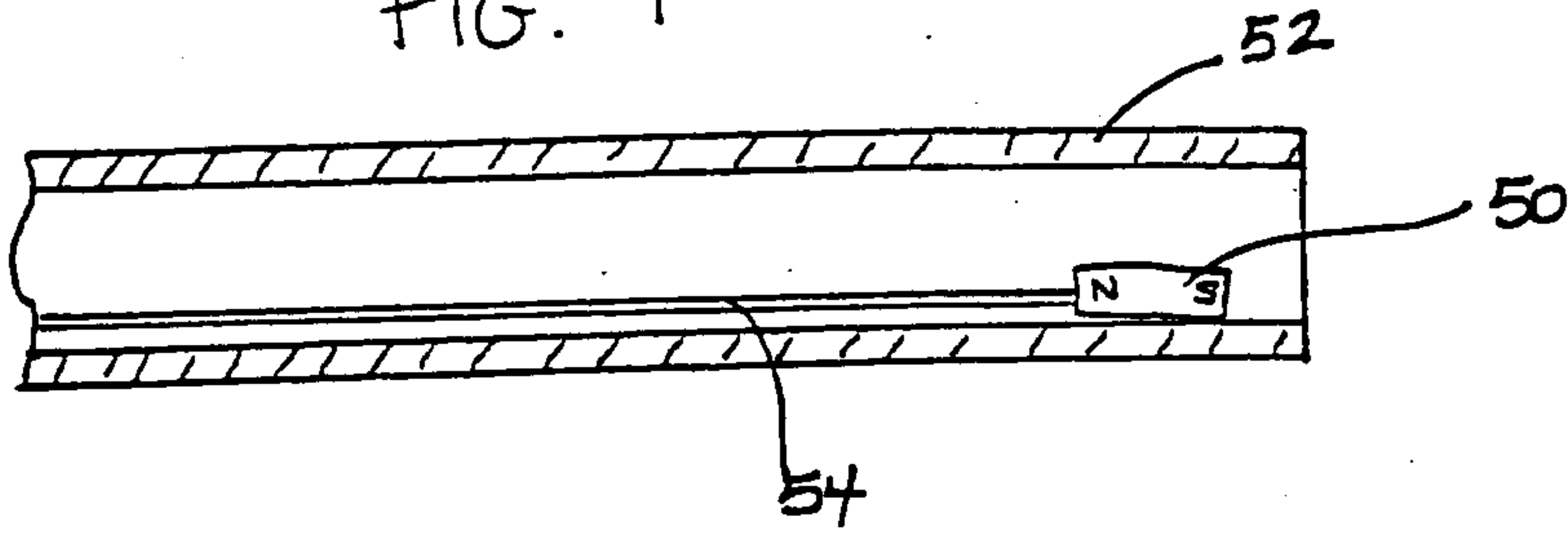

FIG. 10

