



US00D609166S

(12) **United States Design Patent**  
**Brown**

(10) **Patent No.:** **US D609,166 S**

(45) **Date of Patent:** **\*\* Feb. 2, 2010**

(54) **TIRE TREAD**

(75) Inventor: **Robert F. Brown**, Mount Vernon, IL  
(US)

(73) Assignee: **Continental Tire North America, Inc.**,  
Charlotte, NC (US)

(\*\*) Term: **14 Years**

(21) Appl. No.: **29/294,898**

(22) Filed: **Jan. 31, 2008**

(51) **LOC (9) Cl.** ..... **12-15**

(52) **U.S. Cl.** ..... **D12/583; D12/900**

(58) **Field of Classification Search** ..... D12/500-502,  
D12/568, 574, 578, 582-585, 604, 900, 901;  
D21/563, 779; 152/209.1, 209.18, 209.19,  
152/209.21-209.25, 209.27

See application file for complete search history.

(56) **References Cited**

**U.S. PATENT DOCUMENTS**

4,192,366	A *	3/1980	Scriver et al.	.....	152/209.1
D287,953	S *	1/1987	Takeuchi	.....	D12/597
D304,556	S *	11/1989	Tsuda et al.	.....	D12/582
D313,208	S *	12/1990	Cottrell	.....	D12/583
D316,066	S *	4/1991	Wischhusen	.....	D12/582
D316,692	S *	5/1991	Fukumoto	.....	D12/594
5,289,862	A *	3/1994	Schuster	.....	152/209.18
D429,480	S *	8/2000	Bonko	.....	D12/500
D500,472	S *	1/2005	Campana et al.	.....	D12/583

D548,175	S *	8/2007	Martin	.....	D12/603
2002/0157747	A1 *	10/2002	Shimada et al.	.....	152/209.5
2005/0230020	A1 *	10/2005	Miyake	.....	152/209.19

**OTHER PUBLICATIONS**

Michelin XRV Tire; 2005 Tread Design Guide; p. 84, Row 2, Item 2.\*  
Continental HSR Tire; 2005 Tread Design Guide, p. 105, Row 1, Item 2.\*  
Dayton Rib Radial All Position Tire; 2005 Tread Design Guide, p. 107, Row 3, Item 5.\*  
Mitas Implement Tire; 2005 Tread Design Guide, p. 185, Row 3, Item 1.\*

\* cited by examiner

*Primary Examiner*—Caron Veynar

*Assistant Examiner*—Garth Rademaker

(57) **CLAIM**

The ornamental design for a tire tread, as shown and described.

**DESCRIPTION**

FIG. 1 is a perspective view of a tire tread showing my new design, it being understood that the tread pattern is repeated uniformly throughout the circumference of the tire tread, as shown schematically in solid lines.

FIG. 2 is an enlarged fragmentary front elevational view thereof; and,

FIG. 3 is a side elevational view of the design of FIG. 1, the opposite side elevational view being identical thereto.

**1 Claim, 3 Drawing Sheets**

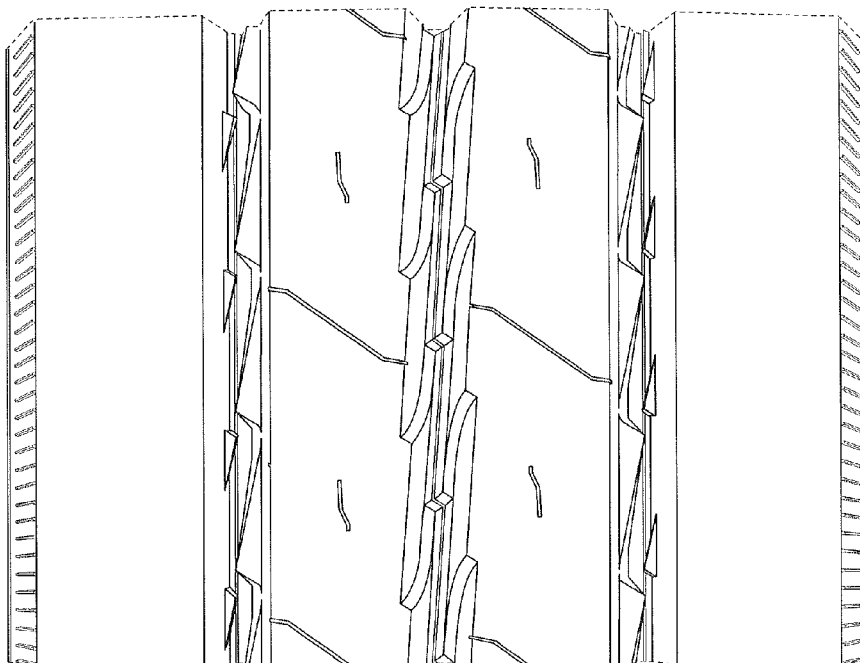

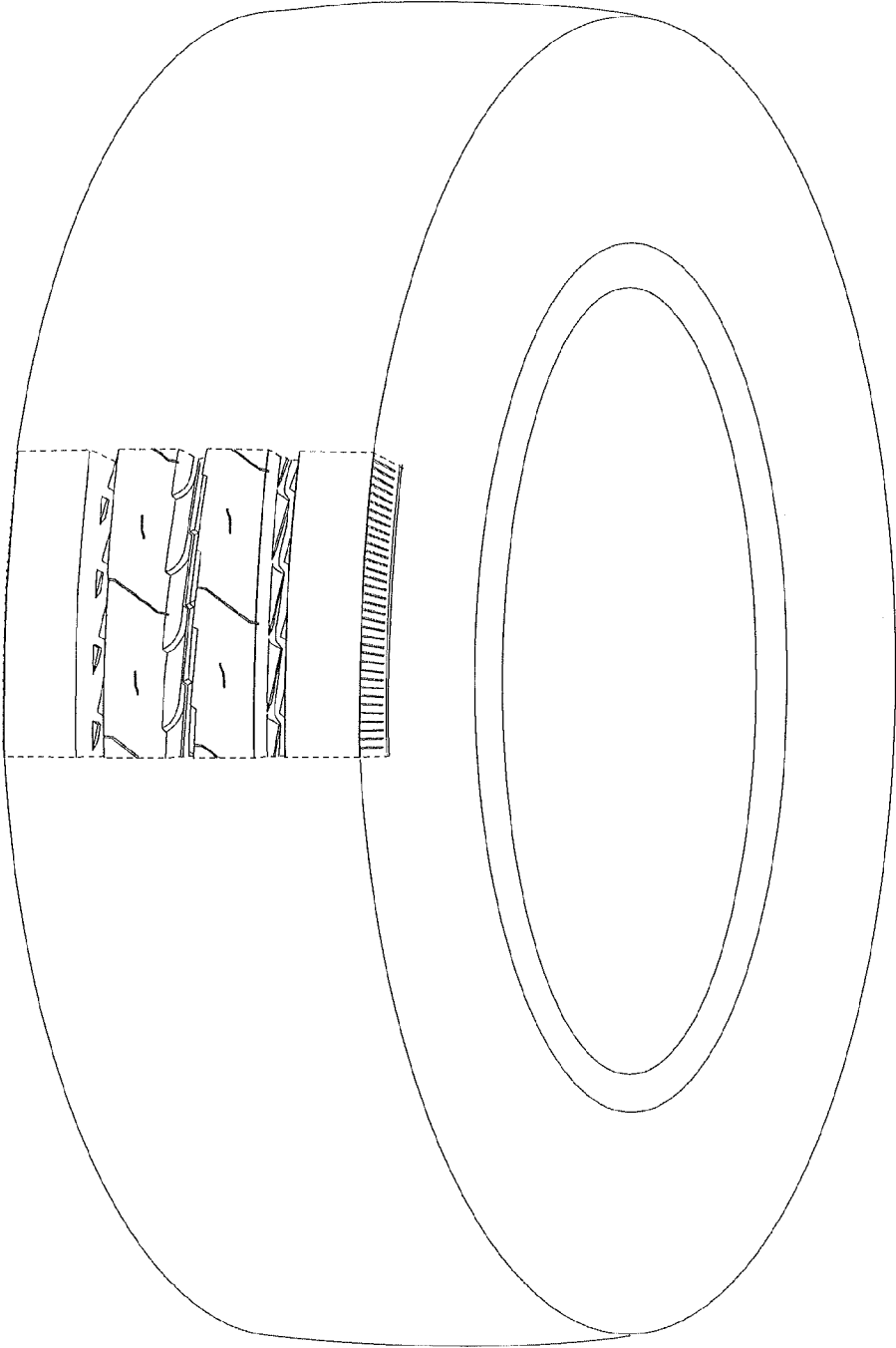

FIG. 1

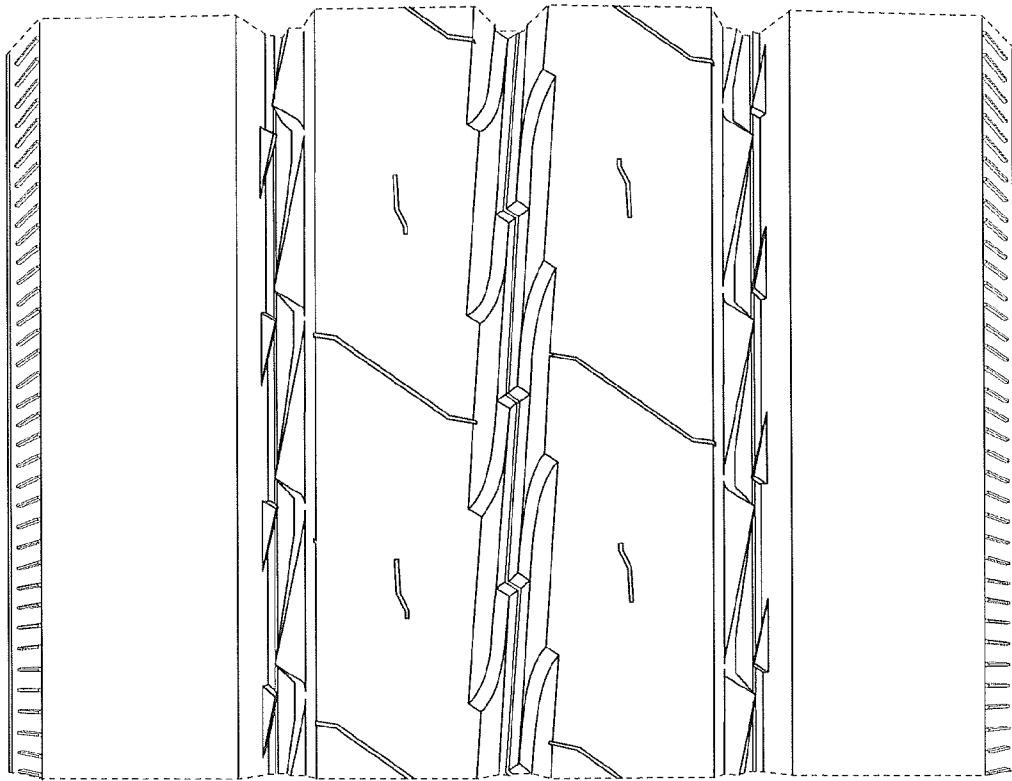

FIG. 2

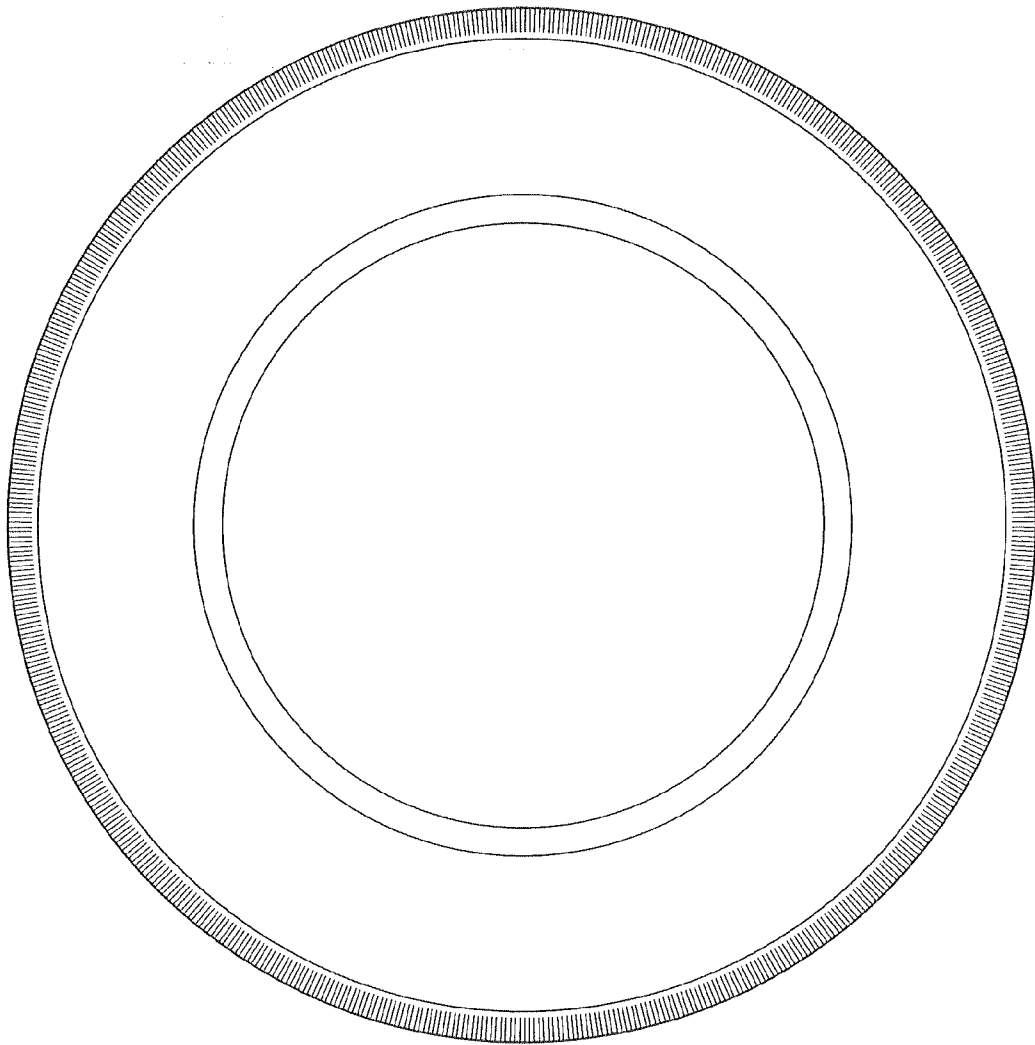

FIG. 3