

Nov. 3, 1936.

M. TARTIKOFF

2,059,826

ATTACHMENT FOR WASH SUITS

Filed Nov. 21, 1933

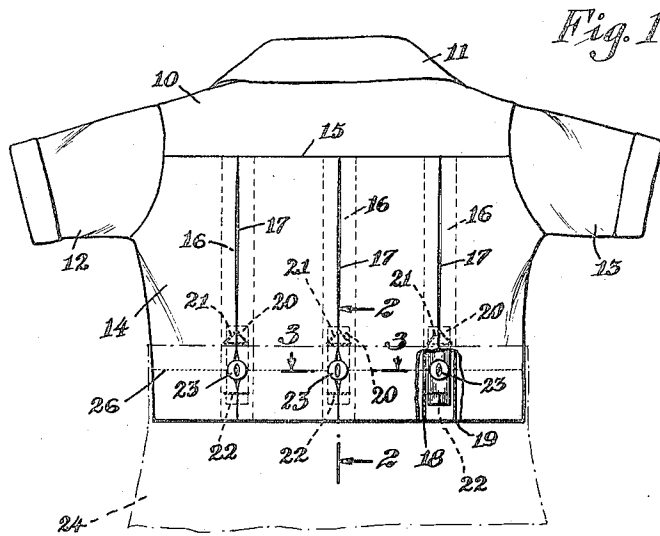

*Fig. 2*

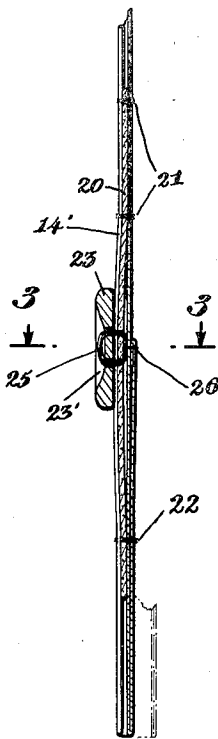

*Fig. 3*

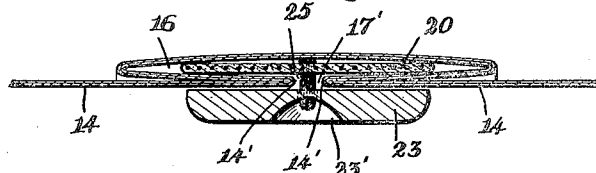

*Fig. 4*

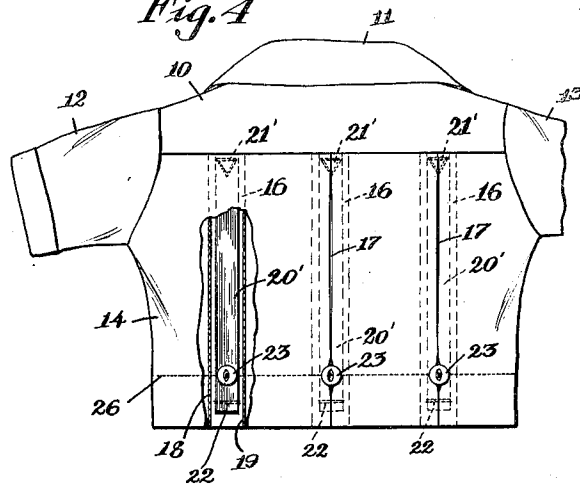

INVENTOR  
Morris Tartikoff  
BY *Alexander Klever*  
ATTORNEY

# UNITED STATES PATENT OFFICE

2,059,826

## ATTACHMENT FOR WASH SUITS

Morris Tartikoff, Brooklyn, N. Y.

Application November 21, 1933, Serial No. 699,004

2 Claims. (Cl. 2—107)

This invention relates generally to attaching means for yieldable connection between garment members and more specifically to wash suits wherein the waist portions are yieldably connected with the pants portions.

The main object of the invention is the provision of a yieldable attachment means situated proximate to the lower edge of a garment such as a wash suit, such that any induced strain between the members attached is compensated by an elastic member.

Another object of the invention is the provision of an attachment means whereby a strain or stretching of a two-piece garment is not accompanied by the transmission of such strain to the shoulder portions and is not accompanied by a destruction of buttonholes, fasteners and fabric.

An additional object of the invention is the provision of an attachment means for attachable members of a garment whereby unusual stretching, strain and distortion are compensated without the usual accompanying strain, destruction, ripping and wear of the fabric thereof.

These objects and other incidental ends and advantages will hereinafter appear in the progress of the disclosure while the novelty of said objects and advantages will appear hereinafter as pointed out in the appended claims.

The accompanying drawing shows preferred embodiments of the invention as applied to a child's wash suit wherein the garment comprises two portions, a waist portion and a pants portion. In the said drawing and in the views thereof and now to be described, corresponding reference characters designate corresponding parts throughout the said views.

Fig. 1 is a rear elevational view of a preferred embodiment of the invention partly broken away, as applied to the waist portion of a child's wash suit.

Fig. 2 is a sectional view along the plane 2—2 of Fig. 1.

Fig. 3 is a sectional view of Fig. 1 along the plane 3—3.

Fig. 4 is another preferred embodiment of the invention as applied to the waist portion of a child's wash suit, showing a rear elevational view partly broken away.

In accordance with the invention and in accordance with the accompanying drawing, 10 represents the upper rear portion of the waist of the garment embodying the invention herein, while 11 is a collar attached thereto and 12 and 13 are sleeve members. 14 designates the general rear portion of the waist and is affixed to

the upper rear portion 10 at the lower edge thereof by stitching 15. The rear portion of the waist 14 is provided with a plurality of inverted pleats 16 preferably vertically disposed and suitably spaced from each other. The said inverted pleats 16 are provided with vertically disposed slits 17 intermediate the folded edges thereof. 18 and 19 represent, as best shown in Fig. 1, the edges from which the fold members of the inverted pleats 16 extend.

20 represents short lengths of elastic which are adapted to be stitched into inverted pleats 16 along and proximate to the lower ends of said pleats. The said elastic members 20 are adapted to be mounted within the said inverted pleats 16 by any of the known means, such as stitching. Stitching 21 affixes the outer folds of inverted pleats 16 to the undersides of the pleats and serves to anchor the upper end of elastic members 20 thereinbetween. Stitchings 22 serve the same functions at the lower ends of said elastic members 20. Intermediate the lengths of said elastic members 20 and preferably along the vertical and central axes thereof are affixed fastener members such as buttons 23.

24 designates in a general way the pants portion of the garment shown in the accompanying drawing and is detachably affixed to the waist portion by means of attachment to the said fastener means 23. The mode of attaching pants portion 24 to said waist portion may be accomplished by cooperating fastener members proximate to the upper edge of the pants portion 24. Such cooperating fastener members are the ordinary expedients such as buttonholes for buttons and female sockets for fastening.

In Fig. 4 the elastic member is shown to extend all along the length of inverted pleats 16 and the features corresponding to the features of Fig. 1 are prime.

As shown, the fastener members 23 attached to the elastic members 20 are ordinary buttons having depressions 23 and being orificed thereat to be stitched into the elastic members 20 by stitching 25.

In accordance with the known practices of the art, the lower edge of the waist portion is hemmed by stitching 26 prior to the forming of the pleats. By referring to Figure 3, it is seen that 14' represents the juxtaposed edges of the folded members of the inverted pleats while 17' shows the distance or width therebetween.

I wish it understood that minor changes and variations in the construction and detail of the disclosure herein may be indulged in without de-

parting from the spirit of the invention and without departing from the scope of the claims.

I claim:

1. In a garment having attachable portions, a back section having a plurality of vertically disposed parallel pockets formed therefrom, each of said pockets having a longitudinally extending opening and being disposed inwardly and running to the lower end of the garment, an elastic strip spaced above the lower end of the garment and running longitudinally in each of the said pockets and being secured at its ends across the said opening, a fastening element carried by each of the said strips and projecting from the

opening in each of the said pockets and being movable longitudinally along the said opening.

2. In a garment having attachable portions, a section formed with a pocket having an opening, the said pocket being disposed inwardly and above the lower end of the garment, an elastic strip running along a portion of the pocket and being secured at its ends across the opening, a fastening element carried by the said strip, being disposed outwardly of the opening in the said pocket and being movable along the opening of the said pocket.

MORRIS TARTIKOFF.