



US00D843112S

(12) **United States Design Patent**
Murray

(10) **Patent No.:** **US D843,112 S**
(45) **Date of Patent:** **** Mar. 19, 2019**

- (54) **MULTI-COMPARTMENT POUCH**
- (71) Applicant: **Pouch Pac Innovations, LLC**,
Sarasota, FL (US)
- (72) Inventor: **R. Charles Murray**, Sarasota, FL (US)
- (73) Assignee: **Pouch Pac Innovations, LLC**,
Sarasota, FL (US)
- (**) Term: **15 Years**
- (21) Appl. No.: **29/588,007**
- (22) Filed: **Dec. 16, 2016**
- (51) **LOC (11) Cl.** **09-04**
- (52) **U.S. Cl.**
USPC **D3/313; D3/301; D9/709**
- (58) **Field of Classification Search**
USPC D3/203.2, 264, 298, 301, 303, 313;
D9/737, 720, 702-709; D7/601, 701,
D7/703, 629; 383/16, 38-40, 210, 210.1,
383/42, 61.1, 61.2, 61.3, 63, 64;
206/256, 257, 260, 265, 267, 271, 274;
220/500, 507, 521-524, 553, 554;
150/100, 101, 111, 112, 115, 118, 120;
53/416; 24/585.12
CPC B65D 33/2591; B65D 31/12; B65D
33/2508; B65D 33/2541; B65D 27/04;
B65D 27/08; B65D 33/04; B65D 75/30;
B65D 81/3261; Y10T 24/45168; Y10T
29/49782; A44B 19/16; B29L 2031/7128
See application file for complete search history.

(56) **References Cited**
U.S. PATENT DOCUMENTS

- 3,809,224 A * 5/1974 Greenwood B65D 81/3266
206/219
- 3,884,412 A * 5/1975 Price B65D 75/30
206/227

- 4,145,449 A * 3/1979 Nelham B65D 81/3266
206/219
- 4,312,473 A * 1/1982 Hoeller B65D 81/3261
206/219
- 4,832,505 A * 5/1989 Ausnit B31B 70/00
383/209
- D344,407 S * 2/1994 Derrickson D3/245
- 5,598,919 A * 2/1997 Taylor A45C 11/005
206/205
- 6,217,216 B1 * 4/2001 Taheri B29C 47/0023
383/207
- D451,378 S * 12/2001 Kinigakis D9/709
- 6,612,002 B1 * 9/2003 Savicki B65D 33/2591
24/30.5 R
- 6,619,843 B2 * 9/2003 Harmanoglu B65D 31/12
229/70
- 6,899,239 B1 * 5/2005 Gray A61J 9/001
215/11.3

(Continued)

Primary Examiner — Cathron C Brooks
Assistant Examiner — W. A. Teddy Falloway
(74) *Attorney, Agent, or Firm* — Dinsmore & Shohl LLP

(57) **CLAIM**

The ornamental design for a multi-compartment pouch, as shown and described.

DESCRIPTION

FIG. 1 is a perspective view of the top and front of a multi-compartment pouch;
FIG. 2 is a front elevational view thereof;
FIG. 3 is a back elevational view thereof;
FIG. 4 is a left side elevational view thereof;
FIG. 5 is a right side elevational view thereof;
FIG. 6 is a top elevational view thereof; and,
FIG. 7 is a bottom elevational view thereof.
It should be appreciated that the broken lines illustrate environmental structure and portions of the multi-compartment pouch that form no part of the claimed design.

1 Claim, 5 Drawing Sheets

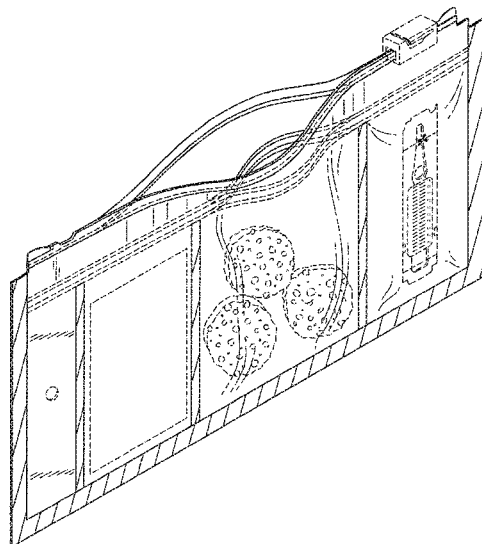

US D843,112 S

(56)

References Cited

U.S. PATENT DOCUMENTS

6,910,806 B2 *	6/2005	Strand	B65D 33/2591 383/204	2005/0063624 A1 *	3/2005	Goto	B65D 75/5805 383/205
6,968,952 B2 *	11/2005	Crevier	B65D 81/3266 206/219	2006/0062956 A1 *	3/2006	Chandaria	G09F 3/10 428/43
7,267,856 B2 *	9/2007	Patel	B29C 66/1122 383/122	2006/0177155 A1 *	8/2006	Owen	B65D 33/2591 383/61.2
D563,241 S *	3/2008	Nimey	D9/705	2008/0240628 A1 *	10/2008	VanLoocke	B65B 29/10 383/210
D601,038 S *	9/2009	Middleton-Schluter	D9/709	2009/0100650 A1 *	4/2009	Kim	B65D 33/2591 24/427
D613,615 S *	4/2010	Hedstrom	D9/702	2010/0142861 A1 *	6/2010	Sam	B65D 31/12 383/38
D641,253 S *	7/2011	Steward	D9/702	2013/0236128 A1 *	9/2013	Bray	B65D 33/12 383/15
8,096,022 B2 *	1/2012	Hui	B65B 9/20 24/30.5 R	2014/0270588 A1 *	9/2014	Blythe	B65D 33/2591 383/64
D660,179 S *	5/2012	Bray	D9/707	2015/0108015 A1	4/2015	Murray	
8,529,129 B2 *	9/2013	Turvey	B65D 77/225 383/44	2015/0266626 A1 *	9/2015	Forman	B65D 75/5805 383/42
D694,651 S *	12/2013	Sam	D9/709	2015/0307233 A1	10/2015	Murray	
D700,065 S *	2/2014	Owens	D9/707	2016/0039575 A1	2/2016	Murray	
D703,547 S *	4/2014	France	D9/703	2016/0090213 A1 *	3/2016	Murray	B65D 27/04 705/317
D709,383 S *	7/2014	Murray		2016/0145030 A1 *	5/2016	Malligan	B65D 65/14 426/120
D709,701 S *	7/2014	Coleman	D3/303	2016/0272374 A1 *	9/2016	Sidoti	B65D 31/12
D709,703 S *	7/2014	Coleman	D3/303	2017/0121060 A1 *	5/2017	Williamson	B65D 31/12
D710,106 S *	8/2014	Coleman	D3/303	2018/0148228 A1 *	5/2018	Bray	B65D 33/2508
D710,212 S *	8/2014	Coleman	D9/709				
D711,106 S *	8/2014	Davidson	D3/303				
8,960,438 B2	2/2015	Murray					
D739,263 S *	9/2015	Sam	D9/709				
D741,197 S *	10/2015	Sam	D9/709				
D764,932 S *	8/2016	Joswick	D9/702				
D783,416 S *	4/2017	Bray	D9/709				
D784,158 S *	4/2017	Bray	D9/709				

* cited by examiner

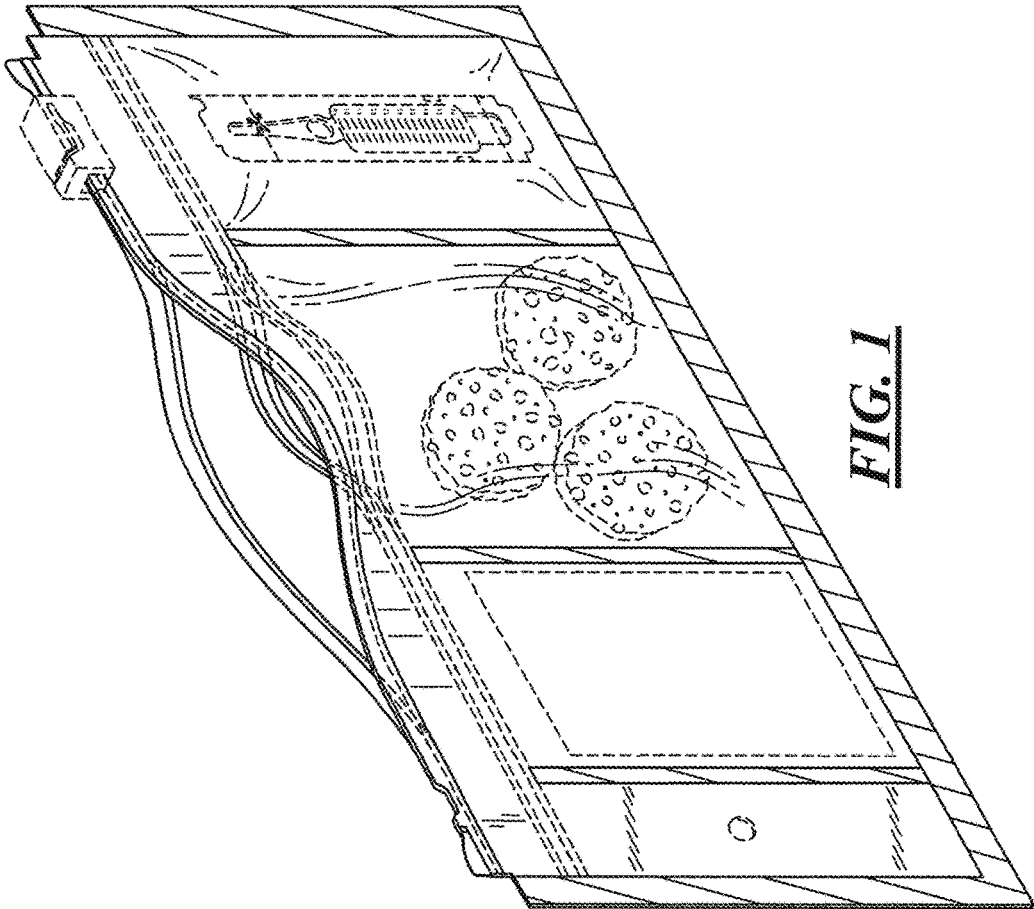

FIG. 1

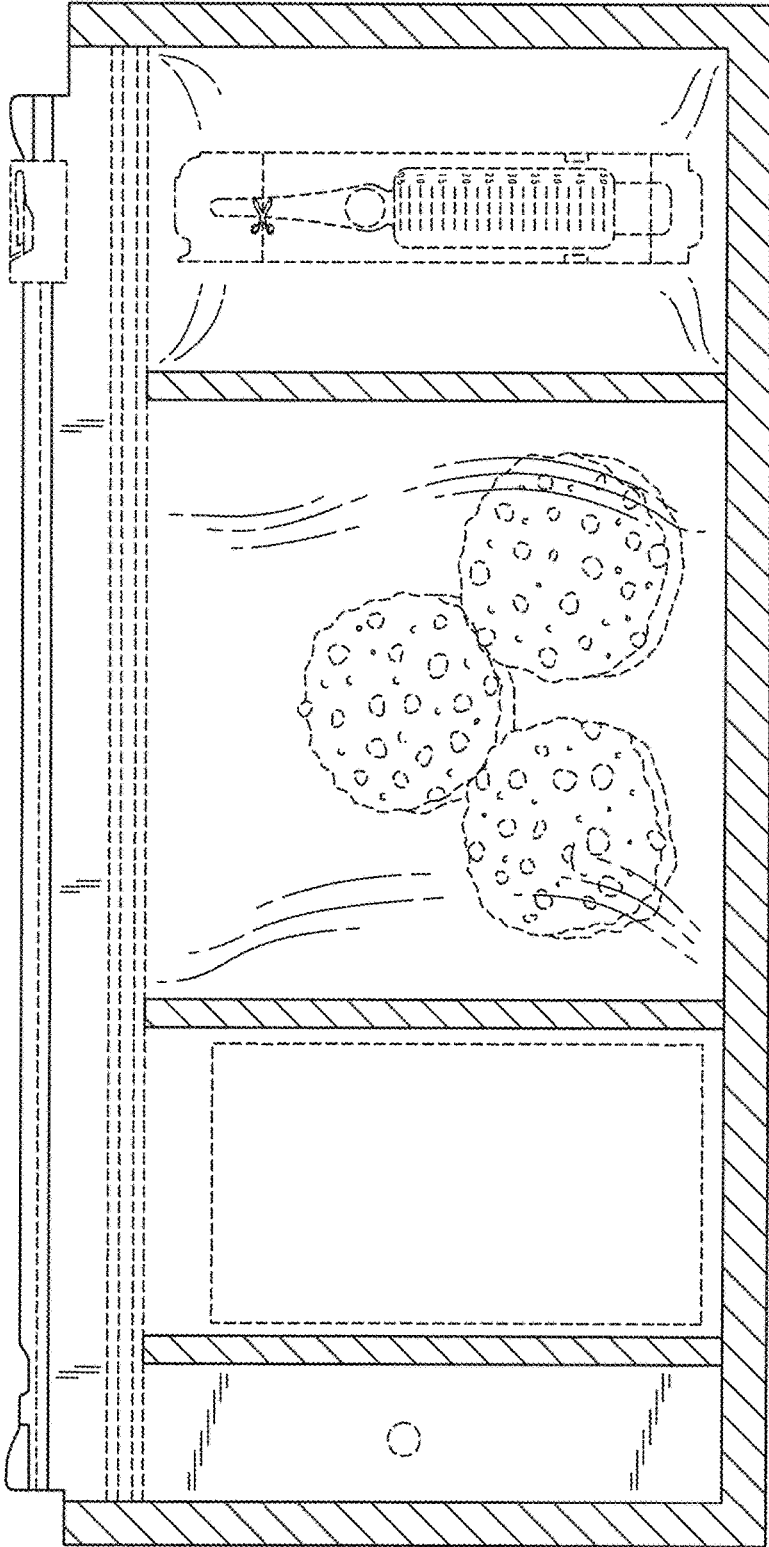

FIG. 2

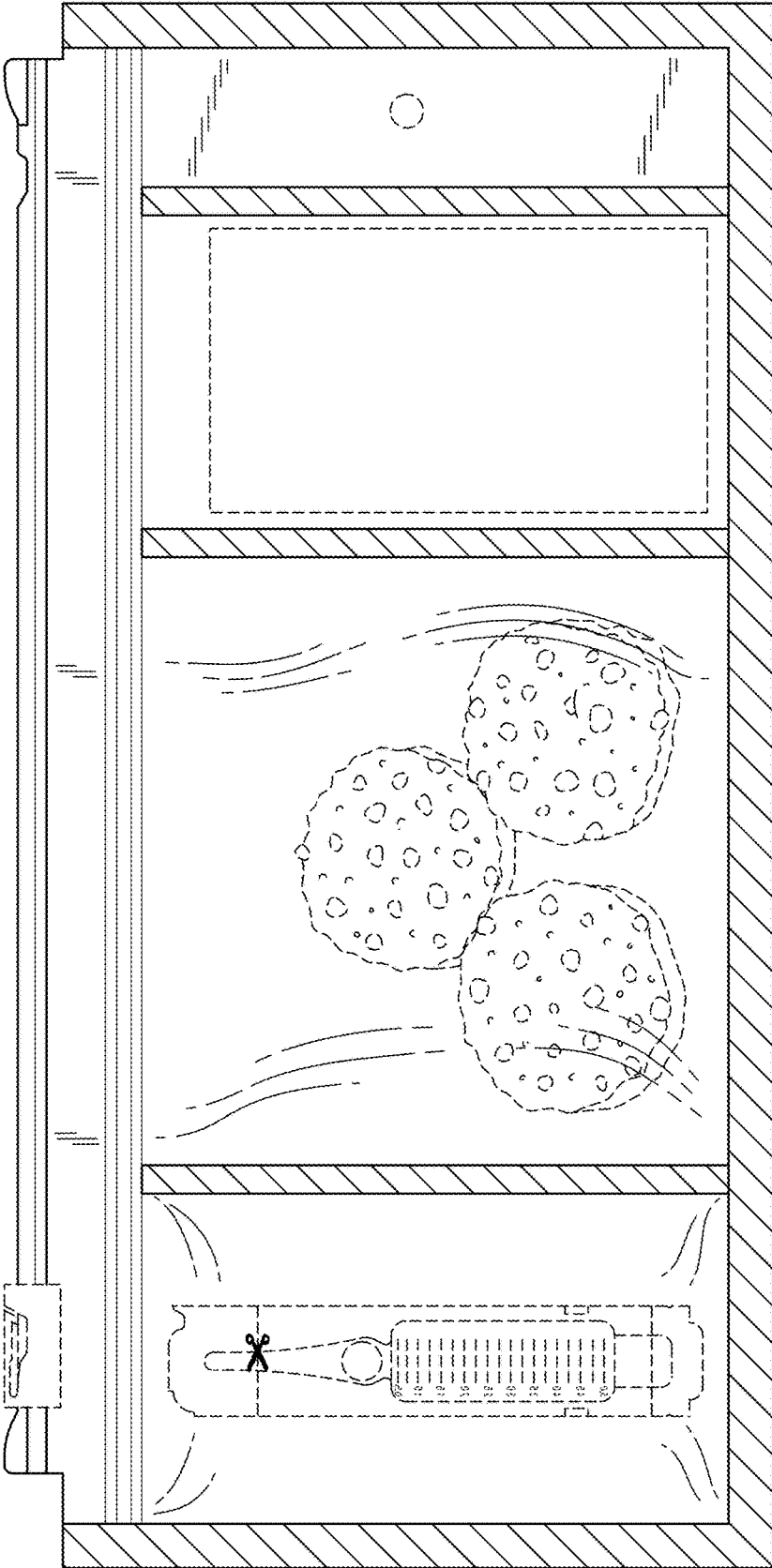

FIG. 3

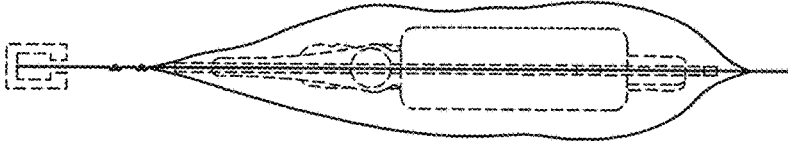

FIG. 5

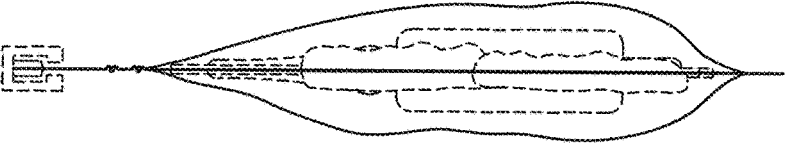

FIG. 4

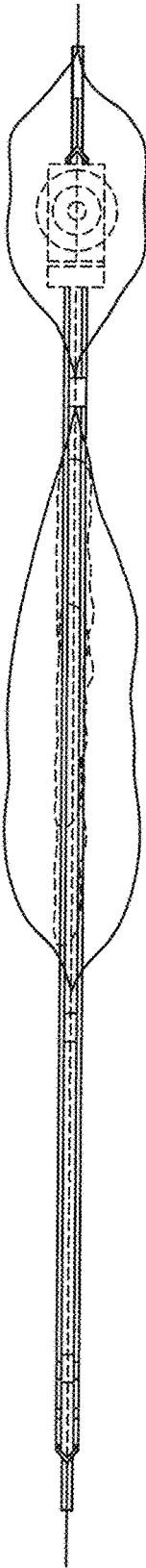

FIG. 6

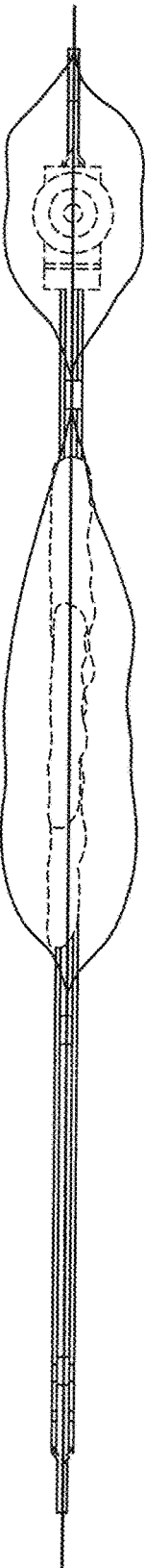

FIG. 7