



(51) International Patent Classification:

G06T 19/00 (2011.01) G06K 9/00 (2022.01)  
G01C 21/36 (2006.01)

(21) International Application Number:

PCT/US2021/057905

(22) International Filing Date:

03 November 2021 (03.11.2021)

(25) Filing Language:

English

(26) Publication Language:

English

(30) Priority Data:

17/105,199 25 November 2020 (25.11.2020) US

(71) Applicant: **ARGO AI, LLC** [US/US]; 2545 Railroad Street, Suite 400, Pittsburgh, PA 15222 (US).

(72) Inventors: **FOLEY, Sean**; 2545 Railroad Street, Suite 400, Pittsburgh, PA 15222 (US). **HAYS, James**; 2545 Railroad Street, Suite 400, Pittsburgh, PA 15222 (US).

(74) Agent: **THORSTAD-FORSYTH, Carol**; Fox Rothschild LLP, 997 Lenox Drive, Lawrenceville, NJ 08648-2311 (US).

(81) Designated States (unless otherwise indicated, for every kind of national protection available): AE, AG, AL, AM, AO, AT, AU, AZ, BA, BB, BG, BH, BN, BR, BW, BY, BZ, CA, CH, CL, CN, CO, CR, CU, CZ, DE, DJ, DK, DM, DO,

DZ, EC, EE, EG, ES, FI, GB, GD, GE, GH, GM, GT, HN, HR, HU, ID, IL, IN, IR, IS, IT, JO, JP, KE, KG, KH, KN, KP, KR, KW, KZ, LA, LC, LK, LR, LS, LU, LY, MA, MD, ME, MG, MK, MN, MW, MX, MY, MZ, NA, NG, NI, NO, NZ, OM, PA, PE, PG, PH, PL, PT, QA, RO, RS, RU, RW, SA, SC, SD, SE, SG, SK, SL, ST, SV, SY, TH, TJ, TM, TN, TR, TT, TZ, UA, UG, US, UZ, VC, VN, WS, ZA, ZM, ZW.

(84) Designated States (unless otherwise indicated, for every kind of regional protection available): ARIPO (BW, GH, GM, KE, LR, LS, MW, MZ, NA, RW, SD, SL, ST, SZ, TZ, UG, ZM, ZW), Eurasian (AM, AZ, BY, KG, KZ, RU, TJ, TM), European (AL, AT, BE, BG, CH, CY, CZ, DE, DK, EE, ES, FI, FR, GB, GR, HR, HU, IE, IS, IT, LT, LU, LV, MC, MK, MT, NL, NO, PL, PT, RO, RS, SE, SI, SK, SM, TR), OAPI (BF, BJ, CF, CG, CI, CM, GA, GN, GQ, GW, KM, ML, MR, NE, SN, TD, TG).

Published:

— with international search report (Art. 21(3))

(54) Title: SYSTEMS AND METHODS FOR MONOCULAR BASED OBJECT DETECTION

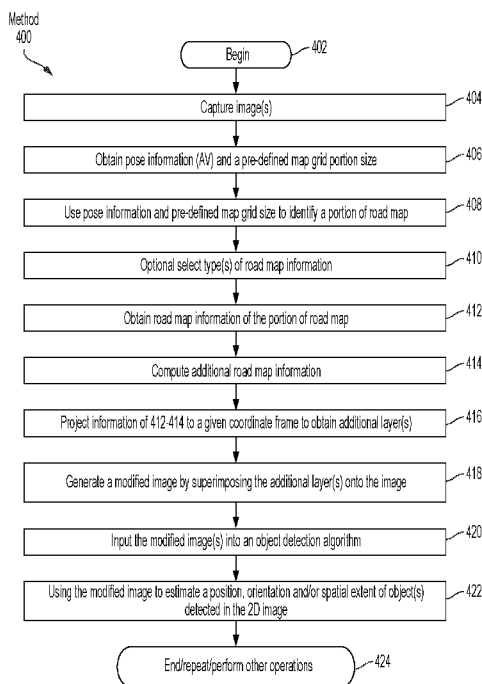

FIG. 4

(57) Abstract: Systems and methods for object detection. The methods comprise: obtaining, by a computing device, an image comprising a plurality of color layers superimposed on each other; generating at least one first additional layer using information contained in a road map (where the first additional layer includes ground height information, ground depth information, drivable geographical area information, map point distance-to-lane center information, lane direction information, or intersection information); generating a modified image by superimposing the first additional layer on the color layers; and causing, by the computing device, control of a vehicle's operation based on the object detection made using the modified image.



## SYSTEMS AND METHODS FOR MONOCULAR BASED OBJECT DETECTION

## BACKGROUND

## Cross-Reference and Claim of Priority

**[0001]** This patent document claims priority to U.S. Patent Application No. 17/105,199 filed November 25, 2020, which is incorporated herein by reference in its entirety.

## Statement of the Technical Field

**[0002]** The present disclosure relates generally to object detection systems. More particularly, the present disclosure relates to implementing systems and methods for monocular based object detection.

## Description of the Related Art

**[0003]** Modern day vehicles have at least one on-board computer and have internet/satellite connectivity. The software running on these on-board computers monitor and/or control operations of the vehicles. The vehicle also comprises LiDAR detectors for detecting objects in proximity thereto. The LiDAR detectors generate LiDAR datasets that measure the distance from the vehicle to an object at a plurality of different times. These distance measurements can be used for identifying objects, tracking movements of the object, making predictions as to the objects trajectory, and planning paths of travel for the vehicle based on the predicted objects trajectory. LiDAR based object detection is costly and sensitive to weather conditions.

## SUMMARY

**[0004]** The present disclosure concerns implementing systems and methods for object detection. The methods comprise: obtaining, by a computing device, an image comprising a plurality of color layers (or channels) superimposed on each other; and generating at least one first additional layer (or channel) using information contained in a road map. The first additional layer(s) (or channel(s)) include(s) ground height information, ground depth information, drivable geographical area information, map point distance-to-lane center information, lane direction

information, or intersection information. A modified image is then generated by superimposing the first additional layer(s) (or channel(s)) on the color layers (or channels). The computing device may cause control of a vehicle's operation based on the object detection made using the modified image.

**[0005]** In some scenarios, the methods comprise obtaining pose information for the vehicle and a pre-defined map grid portion size. This information is used to identify a portion of the road map. The portion of the road map comprises a segment of the road map that (i) is included in a geometric area having a same center point as the vehicle in the road map and (ii) has dimensions equal to dimensions defined by the pre-defined map grid portion size.

**[0006]** In those or other scenarios, the methods comprise: obtaining road map based values for a plurality of geometric point locations in the portion of the road map; and using the road map based values to generate the first additional layer(s) (or channel(es)). The first additional layer(s) (or channel(s)) is generated by: defining a plurality of tiles in a first coordinate system based on the road map based values; defining a polygon for each tile using ground height values of the road map that are associated with respective ones of the road map based values; and converting the plurality of tiles from the first coordinate system to a second coordinate system. The tiles may correspond to a mesh that approximates the ground surface. The road map based values may comprise: values defining a ground surface specified in the road map; values defining a drivable geographical area contained in the road map; ground depth values computed based on a known camera location and ground height information contained in the road map; map point distance-to-lane center values; lane direction values; or intersection values.

**[0007]** In those or other scenarios, the methods comprise: generating at least one second additional layer (or channel) using information contained in a road map. The second additional layer(s) (or channel(s)) include(s) different information than the first additional layer(s) (or channel(s)). The second additional layer(s) (or channel(s)) is(are) superimposed on the color layers (or channels) in addition to the first additional layer(s) (or channel(s)) generate the modified image. The modified image may comprise a combination of at least two of the following layers (or channels) in addition to the plurality of color layers (or channels): a ground

height layer (or channel), a ground depth layer (or channel), a drivable geographical area layer (or channel), a map point distance-to-lane center layer (or channel), a lane direction layer (or channel), and an intersection layer (or channel). An object can be detected in the modified image. A position, an orientation, a spatial extent and/or a classification may be estimated for the object detected in the modified image.

### BRIEF DESCRIPTION OF THE DRAWINGS

[0008] The present solution will be described with reference to the following drawing figures, in which like numerals represent like items throughout the figures.

[0009] FIG. 1 is an illustration of an illustrative system.

[0010] FIG. 2 is an illustration of an illustrative architecture for a vehicle.

[0011] FIG. 3 is an illustration of an illustrative computing device.

[0012] FIG. 4 provides a flow diagram of an illustrative method for object detection.

[0013] FIG. 5 provides an illustration of an illustrative road map.

[0014] FIG. 6 provides images that are useful for understanding the method shown in FIG. 4.

[0015] FIG. 7 provides an illustration of an illustrative grid.

[0016] FIG. 8 provides an illustration of an illustrative polygon.

[0017] FIGS. 9-10 each provide an illustration of an illustrative modified image.

[0018] FIG. 11 provides a block diagram that is useful for understanding how a vehicle is controlled in accordance with the present solution.

### DETAILED DESCRIPTION

[0019] As used in this document, the singular forms “a,” “an,” and “the” include plural references unless the context clearly dictates otherwise. Unless defined otherwise, all technical and scientific terms used herein have the same meanings as commonly understood by one of

ordinary skill in the art. As used in this document, the term “comprising” means “including, but not limited to.” Definitions for additional terms that are relevant to this document are included at the end of this Detailed Description.

**[0020]** An “electronic device” or a “computing device” refers to a device that includes a processor and memory. Each device may have its own processor and/or memory, or the processor and/or memory may be shared with other devices as in a virtual machine or container arrangement. The memory will contain or receive programming instructions that, when executed by the processor, cause the electronic device to perform one or more operations according to the programming instructions.

**[0021]** The terms “memory,” “memory device,” “data store,” “data storage facility” and the like each refer to a non-transitory device on which computer-readable data, programming instructions or both are stored. Except where specifically stated otherwise, the terms “memory,” “memory device,” “data store,” “data storage facility” and the like are intended to include single device embodiments, embodiments in which multiple memory devices together or collectively store a set of data or instructions, as well as individual sectors within such devices.

**[0022]** The terms “processor” and “processing device” refer to a hardware component of an electronic device that is configured to execute programming instructions. Except where specifically stated otherwise, the singular term “processor” or “processing device” is intended to include both single-processing device embodiments and embodiments in which multiple processing devices together or collectively perform a process.

**[0023]** The term “vehicle” refers to any moving form of conveyance that is capable of carrying either one or more human occupants and/or cargo and is powered by any form of energy. The term “vehicle” includes, but is not limited to, cars, trucks, vans, trains, autonomous vehicles, aircraft, aerial drones and the like. An “autonomous vehicle” is a vehicle having a processor, programming instructions and drivetrain components that are controllable by the processor without requiring a human operator. An autonomous vehicle may be fully autonomous in that it does not require a human operator for most or all driving conditions and functions, or it may be semi-autonomous in that a human operator may be required in certain conditions or for

certain operations, or that a human operator may override the vehicle's autonomous system and may take control of the vehicle.

**[0024]** In this document, when terms such as “first” and “second” are used to modify a noun, such use is simply intended to distinguish one item from another, and is not intended to require a sequential order unless specifically stated. In addition, terms of relative position such as “vertical” and “horizontal”, or “front” and “rear”, when used, are intended to be relative to each other and need not be absolute, and only refer to one possible position of the device associated with those terms depending on the device's orientation.

**[0025]** The present solution is described herein in the context of an autonomous vehicle. The present solution is not limited to autonomous vehicle applications. The present solution can be used in other applications such as robotic applications.

**[0026]** The present solution provides an alternative approach to LiDAR based object detection which is costly and sensitive to weather conditions. The present solution generally involves using an object detection algorithm that leverages information contained in a road map (e.g., a pre-defined high definition 3D surface road map) for monocular 3D object detection in, for example, AV applications. Road maps are well known in the art. Results of the object detection may be used for object trajectory prediction, vehicle trajectory generation, and/or collision avoidance. The object detection algorithm can include a machine-learning algorithm that is trained to estimate an object's position, orientation and/or spatial extent based on learned combination(s) of road map features. The road map features include, but are not limited to, a ground height feature, a ground depth feature, a drivable geographical area feature, a map point distance-to-lane center feature, a lane direction feature, and an intersection feature.

**[0027]** During operation, a monocular camera of the AV captures an image (e.g., a 2D image). The image comprises 3 layers (or channels) of information superimposed on each other – a Red (R) layer, a Green (G) layer and a Blue (B) layer. This image is also referred to as an RGB image. Road map information is projected onto the image. This projection is achieved by: obtaining AV pose information (a location defined as 3D map coordinates, an angle and a pointing direction of a vehicle to which the monocular camera is attached); using the AV pose

information and a predefined map grid portion size to identify a portion of a road map to be projected into the image; and generating a modified image with superimposed road map information associated with the identified portion of the road map onto the image. The modified image is generated by adding additional layers (or channels) to the image. The additional layers (or channels) include, but are not limited to, a ground height layer (or channel), a ground depth layer (or channel), a drivable geographical area layer (or channel), a map point distance-to-lane center layer (or channel), lane direction layer (or channel), and/or an intersection layer (or channel). Pixels of the layers (or channel) are aligned with each other in 2D space. The modified image is then used by the object detection algorithm to estimate a position, an orientation, a spatial extent, and/or a classification for at least one object detected in the modified image. The object's position/orientation/spatial extent/classification is(are) then used to control operations of the AV (e.g., for object trajectory prediction, vehicle trajectory planning and/or vehicle motion control). Illustrative implementing systems of the present solution will now be described.

**[0028]** Illustrative Implementing Systems

**[0029]** Referring now to FIG. 1, there is provided an illustration of an illustrative system **100**. System **100** comprises a vehicle **102<sub>1</sub>** that is traveling along a road in a semi-autonomous or autonomous manner. Vehicle **102<sub>1</sub>** is also referred to herein as an AV. The AV **102<sub>1</sub>** can include, but is not limited to, a land vehicle (as shown in FIG. 1), an aircraft, or a watercraft.

**[0030]** AV **102<sub>1</sub>** is generally configured to detect objects **102<sub>2</sub>**, **114**, **116** in proximity thereto. The objects can include, but are not limited to, a vehicle **102<sub>2</sub>**, a cyclist **114** (such as a rider of a bicycle, electric scooter, motorcycle, or the like) and/or a pedestrian **116**. The object detection is achieved in accordance with a novel monocular based object detection process. The novel monocular based object detection process will be described in detail below. The monocular based object detection process can be performed at the AV **102<sub>1</sub>**, at the remote computing device **110**, or partially at both the AV **102<sub>1</sub>** and the remote computing device **110**. Accordingly, information related to object detection may be communicated between the AV and a remote

computing device **110** via a network **108** (e.g., the Internet, a cellular network and/or a radio network). The object detection related information may also be stored in a database **112**.

**[0031]** When such an object detection is made, AV **102<sub>1</sub>** performs operations to: generate one or more possible object trajectories for the detected object; and analyze at least one of the generated possible object trajectories to determine whether or not there is an undesirable level of risk that a collision will occur between the AV and object if the AV is to follow a given trajectory. If not, the AV **102<sub>1</sub>** is caused to follow the given vehicle trajectory. If so, the AV **102<sub>1</sub>** is caused to (i) follow another vehicle trajectory with a relatively low risk of collision with the object or (ii) perform a maneuver to reduce the risk of collision with the object or avoid collision with the object (e.g., brakes and/or changes direction of travel).

**[0032]** Referring now to FIG. 2, there is provided an illustrative system architecture **200** for a vehicle. Vehicles **102<sub>1</sub>** and/or **102<sub>2</sub>** of FIG. 1 can have the same or similar system architecture as that shown in FIG. 2. Thus, the following discussion of system architecture **200** is sufficient for understanding vehicle(s) **102<sub>1</sub>**, **102<sub>2</sub>** of FIG. 1.

**[0033]** As shown in FIG. 2, the vehicle **200** includes an engine or motor **202** and various sensors **204-218** for measuring various parameters of the vehicle. In gas-powered or hybrid vehicles having a fuel-powered engine, the sensors may include, for example, an engine temperature sensor **204**, a battery voltage sensor **206**, an engine Rotations Per Minute (“RPM”) sensor **208**, and a throttle position sensor **210**. If the vehicle is an electric or hybrid vehicle, then the vehicle may have an electric motor, and accordingly will have sensors such as a battery monitoring system **212** (to measure current, voltage and/or temperature of the battery), motor current **214** and voltage **216** sensors, and motor position sensors such as resolvers and encoders **218**.

**[0034]** Operational parameter sensors that are common to both types of vehicles include, for example: a position sensor **236** such as an accelerometer, gyroscope and/or inertial measurement unit; a speed sensor **238**; and an odometer sensor **240**. The vehicle also may have a clock **242** that the system uses to determine vehicle time during operation. The clock **242** may be encoded



into the vehicle on-board computing device, it may be a separate device, or multiple clocks may be available.

**[0035]** The vehicle also will include various sensors that operate to gather information about the environment in which the vehicle is traveling. These sensors may include, for example: a location sensor **260** (e.g., a Global Positioning System (GPS) device); and object detection sensors such as one or more cameras **262**. The sensors also may include environmental sensors **268** such as a precipitation sensor and/or ambient temperature sensor. The object detection sensors may enable the vehicle to detect objects that are within a given distance range of the vehicle **200** in any direction, while the environmental sensors collect data about environmental conditions within the vehicle's area of travel.

**[0036]** During operations, information is communicated from the sensors to an on-board computing device **220**. The on-board computing device **220** analyzes the data captured by the sensors and optionally controls operations of the vehicle based on results of the analysis. For example, the on-board computing device **220** may control: braking via a brake controller **232**; direction via a steering controller **224**; speed and acceleration via a throttle controller **226** (in a gas-powered vehicle) or a motor speed controller **228** (such as a current level controller in an electric vehicle); a differential gear controller **230** (in vehicles with transmissions); and/or other controllers.

**[0037]** Geographic location information may be communicated from the location sensor **260** to the on-board computing device **220**, which may then access a map of the environment that corresponds to the location information to determine known fixed features of the environment such as streets, buildings, stop signs and/or stop/go signals.

**[0038]** Captured images are communicated from the cameras **262** to the on-board computing device **220**. The captured images are processed by the on-board computing device **220** to detect objects in proximity to the vehicle **200** in accordance with the novel monocular based object detection algorithm of the present solution. The novel monocular based object detection algorithm will be described in detail below. It should be noted that the monocular based object detection algorithm uses an object detection algorithm that leverages information contained in a

road map **270** for object detection. The road map **270** can include, but is not limited to, any known or to be known 3D surface road map. The road map **270** is stored in a local memory of the on-board computing device **220**.

**[0039]** The object detection algorithm can employ machine-learning. Machine-learning is a type of Artificial Intelligence (AI) that provides computers with the ability to learn without being explicitly programmed through the automation of analytical model building based on data analysis. In some scenarios, the machine-learning based object detection algorithm is configured to: recognize shapes of objects from various angles, relationships and trends from data; establish baseline profiles for objects based on the recognized information; and make predictions/estimations about object types, positions, orientations and spatial extents for objects detected in inputted images. The baseline profiles for objects may change over time. The machine-learning based object detection algorithm can employ supervised machine learning, semi-supervised machine learning, unsupervised machine learning, and/or reinforcement machine learning. Each of these listed types of machine-learning is well known in the art.

**[0040]** In some scenarios, the machine-learning based object detection algorithm includes, but is not limited to, a decision tree learning algorithm, an association rule learning algorithm, an artificial neural network learning algorithm, a deep learning algorithm, an inductive logic programming based algorithm, a support vector machine based algorithm, a clustering based algorithm, a Bayesian network based algorithm, a representation learning algorithm, a similarity and metric learning algorithm, a sparse dictionary learning algorithm, a genetic algorithm, a rule-based machine-learning algorithm, and/or a learning classifier systems based algorithm. The machine-learning process implemented by the present solution can be built using Commercial-Off-The-Shelf (COTS) tools (e.g., SAS available from SAS Institute Inc. of Cary, North Carolina).

**[0041]** When the on-board computing device **220** detects a moving object, the on-board computing device **220** will generate one or more possible object trajectories for the detected object, and analyze the possible object trajectories to assess the risk of a collision between the object and the AV if the AV was to follow a given vehicle trajectory. If the risk does not exceed

the acceptable threshold, then the on-board computing device **220** may cause the vehicle **200** to follow the given trajectory. If the risk exceeds an acceptable threshold, the on-board computing device **220** performs operations to: (i) determine an alternative vehicle trajectory and analyze whether the collision can be avoided if the AV follows this alternative vehicle trajectory; or (ii) causes the AV to perform a maneuver (e.g., brake, accelerate, or swerve).

[0042] Referring now to FIG. 3, there is provided an illustration of an illustrative architecture for a computing device **300**. The computing device **110** of FIG. 1 and/or the vehicle on-board computing device **220** of FIG. 2 is/are the same as or similar to computing device **300**. As such, the discussion of computing device **300** is sufficient for understanding the computing device **110** of FIG. 1 and the vehicle on-board computing device **220** of FIG. 2.

[0043] Computing device **300** may include more or less components than those shown in FIG. 3. However, the components shown are sufficient to disclose an illustrative solution implementing the present solution. The hardware architecture of FIG. 3 represents one implementation of a representative computing device configured to operate a vehicle, as described herein. As such, the computing device **300** of FIG. 3 implements at least a portion of the method(s) described herein.

[0044] Some or all components of the computing device **300** can be implemented as hardware, software and/or a combination of hardware and software. The hardware includes, but is not limited to, one or more electronic circuits. The electronic circuits can include, but are not limited to, passive components (e.g., resistors and capacitors) and/or active components (e.g., amplifiers and/or microprocessors). The passive and/or active components can be adapted to, arranged to and/or programmed to perform one or more of the methodologies, procedures, or functions described herein.

[0045] As shown in FIG. 3, the computing device **300** comprises a user interface **302**, a Central Processing Unit (CPU) **306**, a system bus **310**, a memory **312** connected to and accessible by other portions of computing device **300** through system bus **310**, a system interface **360**, and hardware entities **314** connected to system bus **310**. The user interface can include input devices and output devices, which facilitate user-software interactions for controlling

operations of the computing device **300**. The input devices include, but are not limited to, a physical and/or touch keyboard **350**. The input devices can be connected to the computing device **300** via a wired or wireless connection (e.g., a Bluetooth® connection). The output devices include, but are not limited to, a speaker **352**, a display **354**, and/or light emitting diodes **356**. System interface **360** is configured to facilitate wired or wireless communications to and from external devices (e.g., network nodes such as access points, etc.).

**[0046]** At least some of the hardware entities **314** perform actions involving access to and use of memory **312**, which can be a Random Access Memory (RAM), a disk drive, flash memory, a Compact Disc Read Only Memory (CD-ROM) and/or another hardware device that is capable of storing instructions and data. Hardware entities **314** can include a disk drive unit **316** comprising a computer-readable storage medium **318** on which is stored one or more sets of instructions **320** (e.g., software code) configured to implement one or more of the methodologies, procedures, or functions described herein. The instructions **320** can also reside, completely or at least partially, within the memory **312** and/or within the CPU **306** during execution thereof by the computing device **300**. The memory **312** and the CPU **306** also can constitute machine-readable media. The term "machine-readable media", as used here, refers to a single medium or multiple media (e.g., a centralized or distributed database, and/or associated caches and servers) that store the one or more sets of instructions **320**. The term "machine-readable media", as used here, also refers to any medium that is capable of storing, encoding or carrying a set of instructions **320** for execution by the computing device **300** and that cause the computing device **300** to perform any one or more of the methodologies of the present disclosure.

**[0047]** Referring now to FIG. 4, there is provided a flow diagram of an illustrative method **400** for object detection. Method **400** begins with **402** and continues with **404** where one or more images are captured by a camera (e.g., camera **262** of FIG. 2). The camera may comprise a monocular camera mounted on an AV (e.g., AV **102<sub>1</sub>** of FIG. 1) that captures images. Each image comprises 3 layers (or channels) of information superimposed on each other – a Red (R)

layer, a Green (G) layer and a Blue (B) layer. This image is also referred to as an RGB image. An illustrative image **600** is shown in FIG. 6.

**[0048]** In **406**, the computing device obtains pose information and a pre-defined map grid portion size (e.g.,  $\leq 200$  meters by  $\leq 200$  meters) from a datastore (e.g., datastore **112** of FIG. 1 and/or memory **312** of FIG. 3). The pose information can include, but is not limited to, vehicle pose information. The vehicle pose information comprises a location of the vehicle defined as 3D map coordinates, an angle of the vehicle relative to a reference point, and a pointing direction of the vehicle.

**[0049]** The vehicle pose information and the pre-defined map grid portion size are used in **408** to identify a portion of the road map that is to be projected into the image captured in **404**. The road map can include, but is not limited to, a 2.5D grid of a surface defined by data points each having an x-coordinate and a y-coordinate. The portion of the road map is identified by: identifying the center point of the AV on the road map; and selecting the portion of the road map that encompasses the AV, where the center of a shape (e.g., a rectangle) having the pre-defined map grid portion size is set to the center point of the AV. An illustration of an illustrative road map **500** is provided in FIG. 5. The center of the AV is represented by dot **502**. The portion **504** of the road map is identified in **408** because it comprises a segment of the map that is included in a rectangle (i) having the same center point as the AV and (ii) dimensions (e.g., length and width) equal to those of the pre-defined map grid portion size. The present solution is not limited to the particulars of FIG. 5.

**[0050]** In optional **410**, one or more types of road map information are selected by the computing device for use in generating a modified image. The types of road map information include, but are not limited to, ground, ground depth, drivable geographical area, map point distance-to-lane center, lane direction, intersection, and/or any other map information relevant to a given application. The type(s) of road map information is(are) selected based on machine-learned information. For example, the computing device machine learns that a combination of ground, ground depth and lane direction provides a most accurate solution in a first scenario, and machine learns that a different combination of ground and map point distance-to-lane center

provide a most accurate solution in a second scenario. The present solution is not limited to the particulars of the example. In other scenarios, the type of road map information is pre-defined.

**[0051]** In **412**, road map information is obtained for a plurality of geometric points  $p$  that are contained in the portion of the road map (identified in **408**) from a datastore (e.g., datastore **112** of FIG. 1 and/or memory **312** of FIG. 3). This road map information includes, but is not limited to, ground information and drivable geographical area information. Illustrations of illustrative road map information obtained in **412** are provided in FIG. 6. The ground information obtained from a road map is shown plotted in an xy-coordinate system within graph **602**. Each point of a ground surface is defined by a value having an x-coordinate and a y-coordinate. The drivable geographical area information is available as a binary value (drivable or non-) for each point in the grid. The drivable geographical area information obtained from a road map is shown plotted in an xy-coordinate system within graph **606**. Each point of a drivable geographical area within the road map is defined by a value having an x-coordinate and a y-coordinate. Such ground information and drivable geographical area information is well known.

**[0052]** In **414**, additional map information is computed by the computing device. The additional map information includes, but is not limited to, ground depth information, map point distance-to-lane center information, lane direction information, and/or intersection information. Ground depth information is derived from information contained in the road map and other information associated with a monocular camera. Thus, the ground depth information is derived from information stored in a datastore (e.g., datastore **112** of FIG. 1 and/or memory **312** of FIG. 3). This information includes, but is not limited to, ground height information, a known camera height, and/or a known camera location. Illustrative ground depth information is shown in graph **604** of FIG. 6. The ground depth information is computed using a Euclidean distance algorithm. Each Euclidean distance value represents a distance between a known location of a camera in 3-dimensional space and a given ground point location (i.e., defined by an x-coordinate and y-coordinate from the grid, and a z-coordinate from the ground height information). Each Euclidean distance value is defined by a single number defining a relation between two locations in 3-dimensional space, and thus is plotted in an xy-coordinate system on graph **604**.

**[0053]** A map point distance-to-lane center value is computed by the computing device for each geometric point location (i.e., defined by an x-coordinate and y-coordinate) in the map. The nearest centerline to a map location is defined as whichever centerline of a plurality of centerlines contains the closest map point (in Euclidean distance in  $(x, y)$ ; vertical distance is ignored) to the map location.  $C$  is a set of centerlines, where  $c \in C$  consists of a set of geometric points  $p \in c$ . Distance is defined as the 2-norm. The nearest centerline  $\hat{c}$  to a map location  $l$  is defined by mathematical equation (1).

$$\hat{c} = \min_{c \in C} (\min_{p \in c} (\|p - l\|)) \quad (1)$$

where  $p$  represents an ordered set of geometric points in the centerline. Illustrative map point distance-to-lane center value information is shown in graph **608** of FIG. 6. The value of the nearest centerline  $\hat{c}$  for each map location  $l$  is defined by an x-coordinate and a y-coordinate, and thus is plotted in an xy-coordinate system on graph **608**.

**[0054]** A lane direction value is determined for each geometric point location  $l$  in the map. For example, a nearest centerline  $\hat{c}$  is identified for a given geometric point location  $l$ . The direction of the geometric point location is then set to the lane direction defined for the nearest centerline. The lane direction is defined as a 2-vector with an x-component and y-component. Illustrative lane direction information is shown in graph **610** of FIG. 6. Each lane direction is plotted in an xy-coordinate system on graph **610**.

**[0055]** An intersection value is determined for each geometric point location  $l$  in the map. For example, a nearest centerline  $\hat{c}$  is identified for a given geometric point location  $l$ . A determination is then made as to whether the nearest centerline is in an intersection contained in the map. This determination can be made based on a look-up table associated with the map or based on xyz-coordinates defining the nearest centerline and xyz-coordinates defining intersections within the map. If the xyz-coordinates of the nearest centerline fall within an area of an intersection, then a determination is made that the given geometric point location is in the intersection. As such, the intersection is assigned to the given geometric point location. Each intersection is defined by an x-component and y-component. Illustrative intersection information

is shown in graph **612** of FIG. 6. Each intersection is plotted in an xy-coordinate system on graph **612**.

[0056] In **416**, the map information of **412-414** is projected to a given coordinate frame to obtain additional layers (or channels). This projection is achieved by defining a grid on each graph (e.g., graphs **602-612**). An illustrative grid **700** is shown in FIG. 7. The grid **700** comprises a plurality of tiles (or cells) **702**. Each point **704** where two lines of the grid **700** meet (or intersect) defines a location of a geometric point of the map. Each tile (or cell) has four corners. Each corner is defined by a geometric point. Each geometric point location has a ground height value associated therewith. Each geometric point location has an identifier assigned thereto which is defined by a row number and a column number. For example, a first point has an identifier *p11* since it resides in a first row and a first column. A second point has an identifier *p12* since it resides in a the first row and the second column, etc. A last point has an identifier *pmj* since it resides in the  $m^{\text{th}}$  row and the  $j^{\text{th}}$  column. The present solution is not limited to the particulars of this example. The ground height values are used to define each tile (or cell) *p11*, . . . , *pmj* as a 4-polygon in 3D space. An illustrative 4-polygon **800** for a given tile (or cell) is shown in FIG. 8. The 4-polygons are then projected into a camera frame or view using a perspective transformation algorithm, i.e., is converted from an xyz-coordinate system to a uv-coordinate system. Perspective transformation algorithms are well known. Perspective transformation algorithms generally involve mapping the four points in plane A to four points in a plane B. This mapping involves transforming/converting x-coordinate values to u-coordinate values, and y-coordinate values to v-coordinate values. A color for each projected 4-polygon is set to a color value of a select point of the polygon or is set to an average of the color values for the points of the polygon. The polygons defined by the uv-coordinates are then drawn on the camera frame in a top-to-bottom manner relative to the v-axis.

[0057] Illustrations of illustrative additional layers (or channels) are provided in FIG. 6. Layer **614** comprises ground height information plotted in a uv-coordinate system. Layer (or channel) **616** comprises ground depth information plotted in a uv-coordinate system. Layer (or channel) **618** comprises derivable geographical area information plotted in a uv-coordinate



system. Layer (or channel) **620** comprises map point distance-to-lane center information plotted in a uv-coordinate system. Layer (or channel) **622** comprises lane direction information plotted in a uv-coordinate system. Layer (or channel) **624** comprises intersection information plotted in a uv-coordinate system. The present solution is not limited to the particulars of FIG. 6.

**[0058]** In **418** of FIG. 4, a modified image is generated by superimposing the additional layer(s) of road map information onto the image captured in **404**. An illustration of an illustrative modified image **900** is provided in FIG. 9. Another illustrative modified image **1000** is provided in FIG. 10. As shown in FIG. 10, the modified image **1000** comprises an R layer (or channel) **1002**, a G layer (or channel) **1004**, a B layer (or channel) **1006**, a ground height layer (or channel) **1008**, a ground depth layer (or channel) **1010**, a derivable geographical area layer (or channel) **1012**, a map point distance-to-lane center layer (or channel) **1014**, a lane direction layer (or channel) **1016**, and an intersection layer (or channel) **1018**. The present solution is not limited to the particulars of FIG. 10. The modified image can include more or less layers (or channels) of road map information than that show in FIGS. 9-10.

**[0059]** The modified image is input into an object detection algorithm of a computing device (e.g., computing device **110** of FIG. 1, vehicle on-board computing device **220** of FIG. 2, and/or computing device **300** of FIG. 3), as shown by **420**. The object detection algorithm is generally configured to estimate a position, an orientation, a spatial extent for at least one object detected in the modified image, and/or object classification, as shown by **422**. In some scenarios, one of the following machine learning algorithms is employed in **422** for 3D object detection: a Deep MANTA algorithm, a 3D-RCNN algorithm, an RoI-10D algorithm, a Mono3D++ algorithm, MonoGRNet algorithm, or MonoGRNet V2 algorithm. Subsequently, **424** is performed where method **400** ends or other processing is performed (e.g., return to **402**).

**[0060]** The position, orientation, spatial extent and object classification generated during method **400** can be used by an AV for object trajectory prediction, vehicle trajectory generation, and/or collision avoidance. A block diagram is provided in FIG. 11 that is useful for understanding how vehicles control is achieved in accordance with the object related information estimated based on the modified image. All or some of the operations performed in FIG. 11 can

be performed by the on-board computing device of a vehicle (e.g., AV **102<sub>1</sub>** of FIG. 1) and/or a remote computing device (e.g., computing device **110** of FIG. 1).

**[0061]** In block **1102**, a location of the vehicle is detected. This detection can be made based on sensor data output from a location sensor (e.g., location sensor **260** of FIG. 2) of the vehicle. This sensor data can include, but is not limited to, GPS data. Information **1120** specifying the detected location of the vehicle is then passed to block **1106**.

**[0062]** In block **1104**, an object is detected within proximity of the vehicle. This detection is made based on sensor data output from a camera (e.g., camera **262** of FIG. 2) of the vehicle. The manner in which the object detection is achieved was discussed above in relation to FIGS. 4-10. Information about the detected object **1122** is passed to block **1106**. This information includes, but is not limited to a position of an object, an orientation of the object, a spatial extent of the object, an initial predicted trajectory of the object, a speed of the object, and/or a classification of the object. The initial predicted object trajectory can include, but is not limited to, a linear path pointing in the heading direction of the object.

**[0063]** In block **1106**, a vehicle trajectory is generated using the information from blocks **1102** and **1104**. Techniques for determining a vehicle trajectory are well known in the art. Any known or to be known technique for determining a vehicle trajectory can be used herein without limitation. For example, in some scenarios, such a technique involves determining a trajectory for the AV that would pass the object when the object is in front of the AV, the object has a heading direction that is aligned with the direction in which the AV is moving, and the object has a length that is greater than a threshold value. The present solution is not limited to the particulars of this scenario. The vehicle trajectory **1124** can be determined based on the location information **1120**, the object detection information **1122**, and/or a road map (e.g., road map **270** of FIG. 2 which is pre-stored in a datastore of the vehicle). The vehicle trajectory **1124** may represent a smooth path that does not have abrupt changes that would otherwise provide passenger discomfort. For example, the vehicle trajectory is defined by a path of travel along a given lane of a road in which the object is not predicted travel within a given amount of time. The vehicle trajectory **1124** is then provided to block **1108**.

**[0064]** In block **1108**, a steering angle and velocity command is generated based on the vehicle trajectory **1124**. The steering angle and velocity command is provided to block **1110** for vehicle dynamics control.

**[0065]** Although the present solution has been illustrated and described with respect to one or more implementations, equivalent alterations and modifications will occur to others skilled in the art upon the reading and understanding of this specification and the annexed drawings. In addition, while a particular feature of the present solution may have been disclosed with respect to only one of several implementations, such feature may be combined with one or more other features of the other implementations as may be desired and advantageous for any given or particular application. Thus, the breadth and scope of the present solution should not be limited by any of the above described embodiments. Rather, the scope of the present solution should be defined in accordance with the following claims and their equivalents.

## CLAIMS

What is claimed is:

1. A method for object detection, comprising:
  - obtaining, by a computing device, an image comprising a plurality of color layers superimposed on each other;
  - generating at least one first additional layer using information contained in a road map, the at least one first additional layer including one of the following types of information: ground height information, ground depth information, drivable geographical area information, map point distance-to-lane center information, lane direction information, and intersection information;
  - generating a modified image by superimposing the at least one first additional layer on the color layers; and
  - causing, by the computing device, control of a vehicle's operation based on the object detection made using the modified image.
2. The method according to claim 1, further comprising obtaining pose information for the vehicle and a pre-defined map grid portion size.
3. The method according to claim 2, further comprising using the pose information and the pre-defined map grid portion size to identify a portion of the road map.
4. The method according to claim 3, wherein the portion of the road map comprises a segment of the road map that (i) is included in a geometric area having a same center point as the vehicle in the road map and (ii) has dimensions equal to dimensions defined by the pre-defined map grid portion size.
5. The method according to claim 3, further comprising:
  - obtaining road map based values for a plurality of geometric point locations in the portion of the road map; and

using the road map based values to generate the at least one first additional layer.

6. The method according to claim 5, wherein the at least one first additional layer is generated by:

defining a plurality of tiles in a first coordinate system based on the road map based values;

defining a polygon for each said tile using ground height values of the road map that are associated with respective ones of the road map based values; and

converting the plurality of tiles from the first coordinate system to a second coordinate system.

7. The method according to claim 5, wherein the road map based values comprise: values defining a ground surface specified in the road map; values defining a drivable geographical area contained in the road map; ground depth values computed based on a known camera location and ground height information contained in the road map; map point distance-to-lane center values; lane direction values; or intersection values.

8. The method according to claim 1, further comprising:

generating at least one second additional layer using information contained in the road map, the at least one second additional layer including different information than the at least one first additional layer;

wherein the at least one second additional layer is superimposed on the color layers in addition to the at least one first additional layer to generate the modified image.

9. The method according to claim 1, wherein the modified image comprises a combination of at least two of the following layers in addition to the plurality of color layers: a ground height layer, a ground depth layer, a drivable geographical area layer, a map point distance-to-lane center layer, a lane direction layer, and an intersection layer.

10. The method according to claim 1, further comprising estimating at least one of a position, an orientation, a spatial extent and a classification for at least one object detected in the modified image.

11. A system, comprising:

a processor;

a non-transitory computer-readable storage medium comprising programming instructions that are configured to cause the processor to implement a method for object detection, wherein the programming instructions comprise instructions to:

obtain an image comprising a plurality of color layers superimposed on each other;

generate at least one first additional layer using information contained in a road map, the additional layer including one of the following types of information: ground height information, ground depth information, drivable geographical area information, map point distance-to-lane center information, lane direction information, and intersection information;

generate a modified image by superimposing the at least one first additional layer on the color layers; and

cause control of a vehicle's operation based on the object detection made using the modified image.

12. The system according to claim 11, wherein the programming instructions further comprise instructions to obtain pose information for the vehicle and a pre-defined map grid portion size.

13. The system according to claim 12, wherein the programming instructions further comprise instructions to use the pose information and the pre-defined map grid portion size to identify a portion of the road map.

14. The system according to claim 13, wherein the portion of the road map comprises a segment of the road map that (i) is included in a geometric area having a same center point as the vehicle in the road map and (ii) has dimensions equal to dimensions defined by the pre-defined map grid portion size.

15. The system according to claim 13, wherein the programming instructions further comprise instructions to:

obtain road map based values for a plurality of geometric point locations in the portion of the road map; and

use the road map based values to generate the at least one first additional layer.

16. The system according to claim 15, wherein the at least one first additional layer is generated by:

defining a plurality of tiles in a first coordinate system based on the road map based values;

defining a polygon for each said tile using ground height values of the road map that are associated with respective ones of the road map based values; and

converting the plurality of tiles from the first coordinate system to a second coordinate system.

17. The system according to claim 15, wherein the road map based values comprise: values defining a ground surface specified in the road map; values defining a drivable geographical area contained in the road map; ground depth values computed based on a known camera location and ground height information contained in the road map; map point distance-to-lane center values; lane direction values; or intersection values.

18. The system according to claim 11, wherein the programming instructions further comprise instructions to:

generate at least one second additional layer using information contained in the road map, the at least one second additional layer including different information than the at least one first additional layer;

wherein the at least one second additional layer is superimposed on the color layers in addition to the at least one first additional layer to generate the modified image.

19. The system according to claim 11, wherein the modified image comprises a combination of at least two of the following layers in addition to the plurality of color layers: a ground height layer, a ground depth layer, a drivable geographical area layer, a map point distance-to-lane center layer, a lane direction layer, and an intersection layer.

20. A non-transitory computer-readable medium that stores instructions that, when executed by at least one computing device, configured to cause the at least one computing device to perform operations comprising:

obtaining, by a computing device, an image comprising a plurality of color layers superimposed on each other;

generating at least one first additional layer using information contained in a road map, the at least one first additional layer including one of the following types of information: ground height information, ground depth information, drivable geographical area information, map point distance-to-lane center information, lane direction information, and intersection information;

generating a modified image by superimposing the at least one first additional layer on the color layers; and

causing, by the computing device, control of a vehicle's operation based on the object detection made using the modified image.



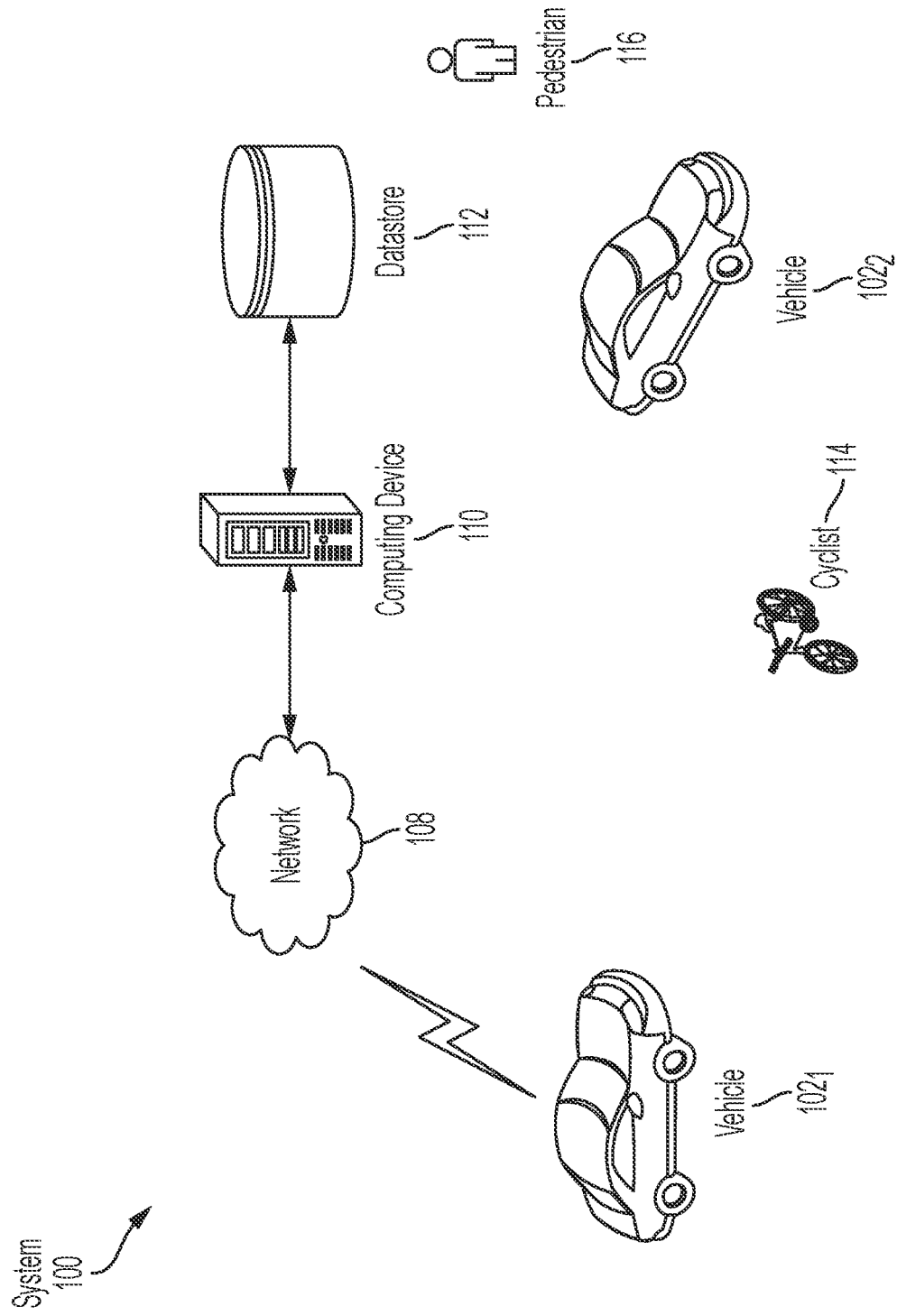

FIG. 1

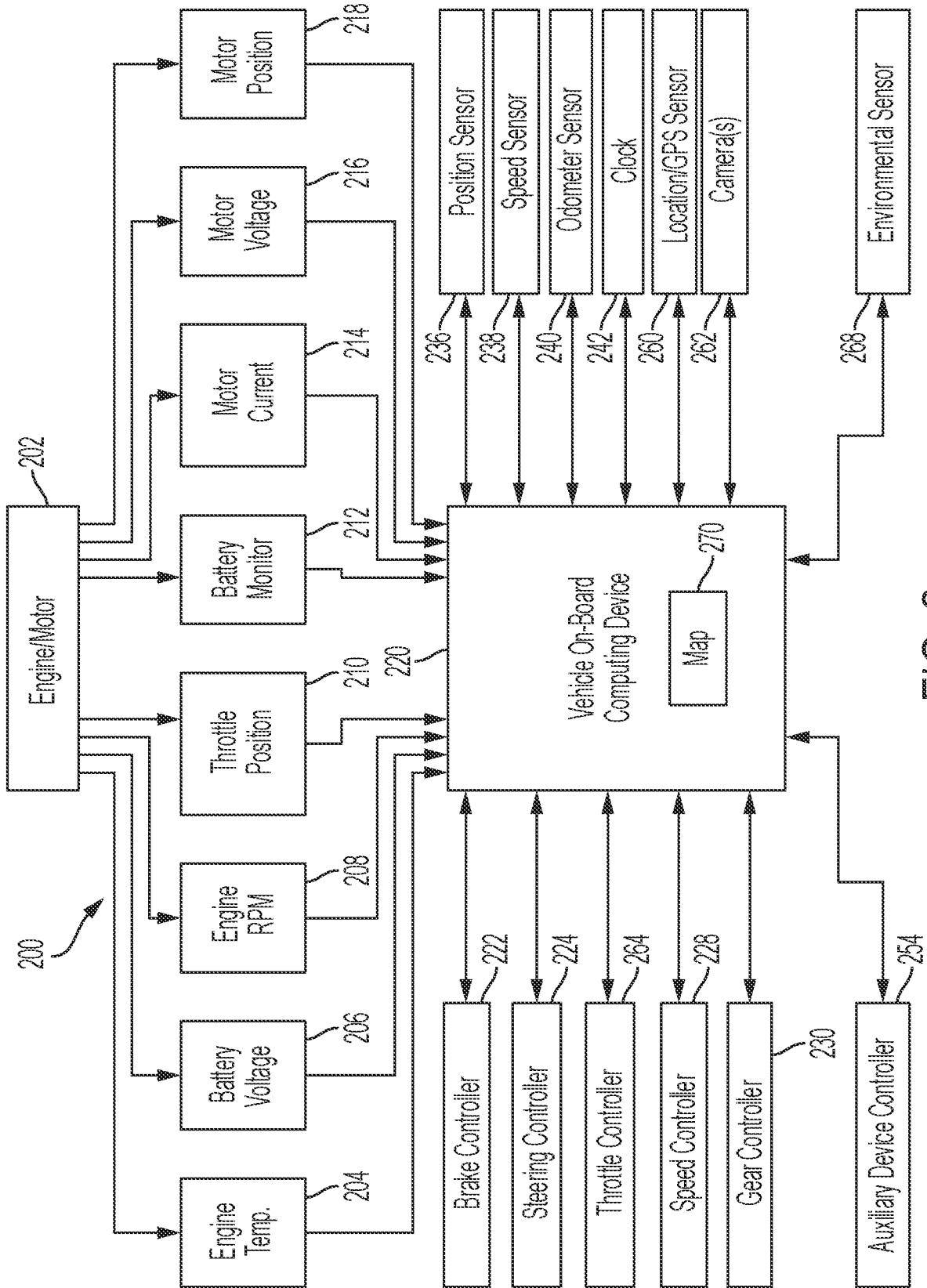

FIG. 2

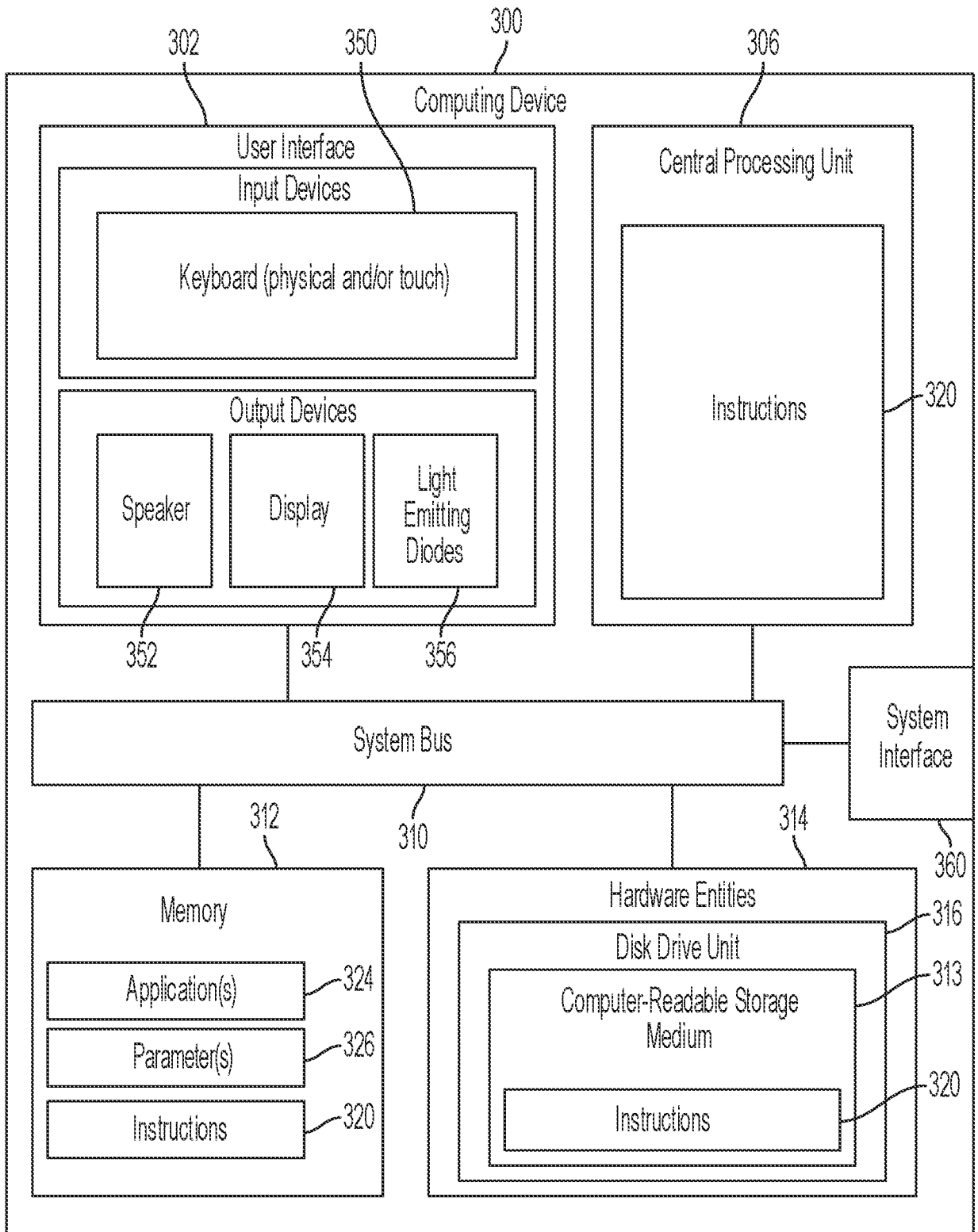

FIG. 3

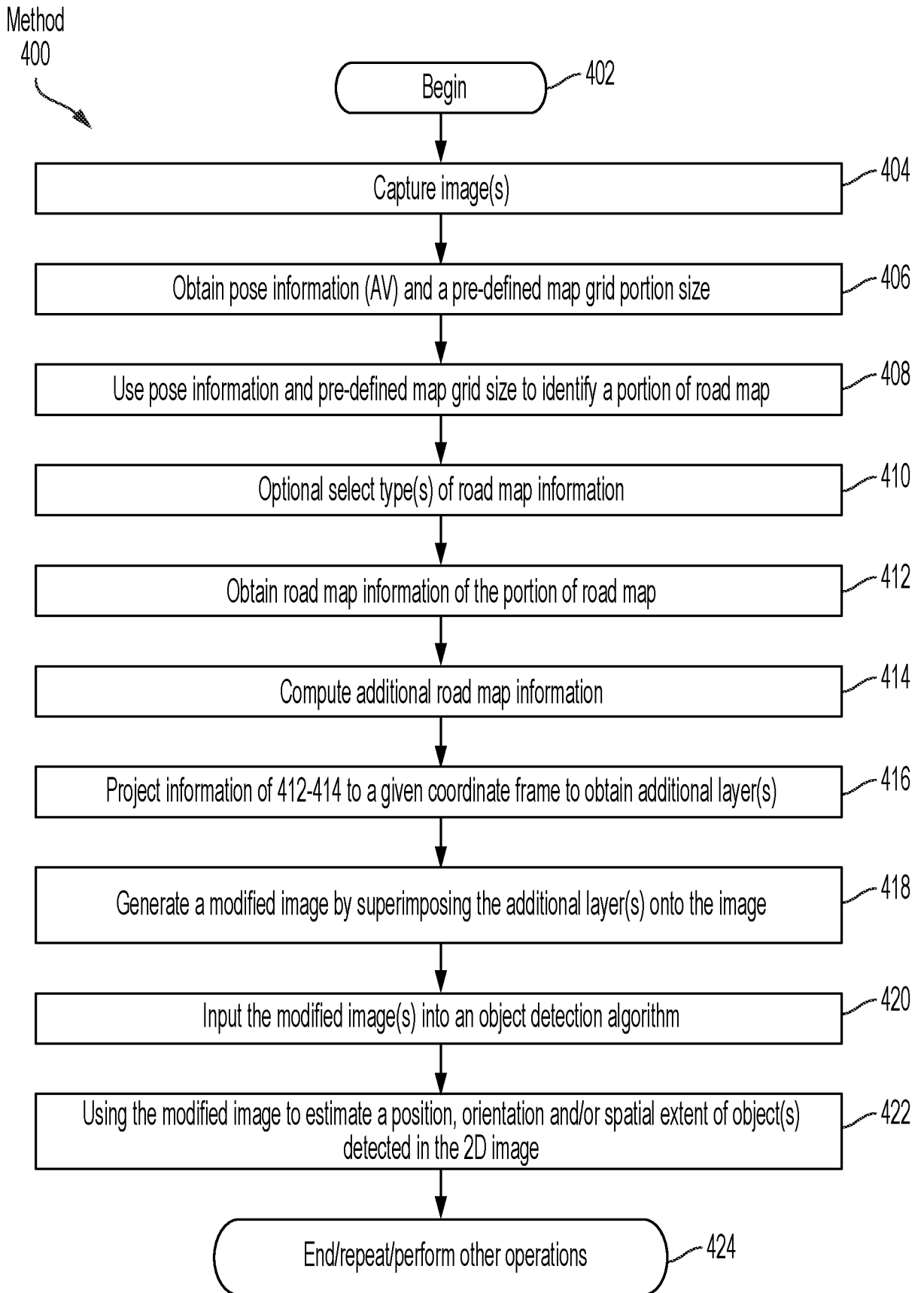

FIG. 4

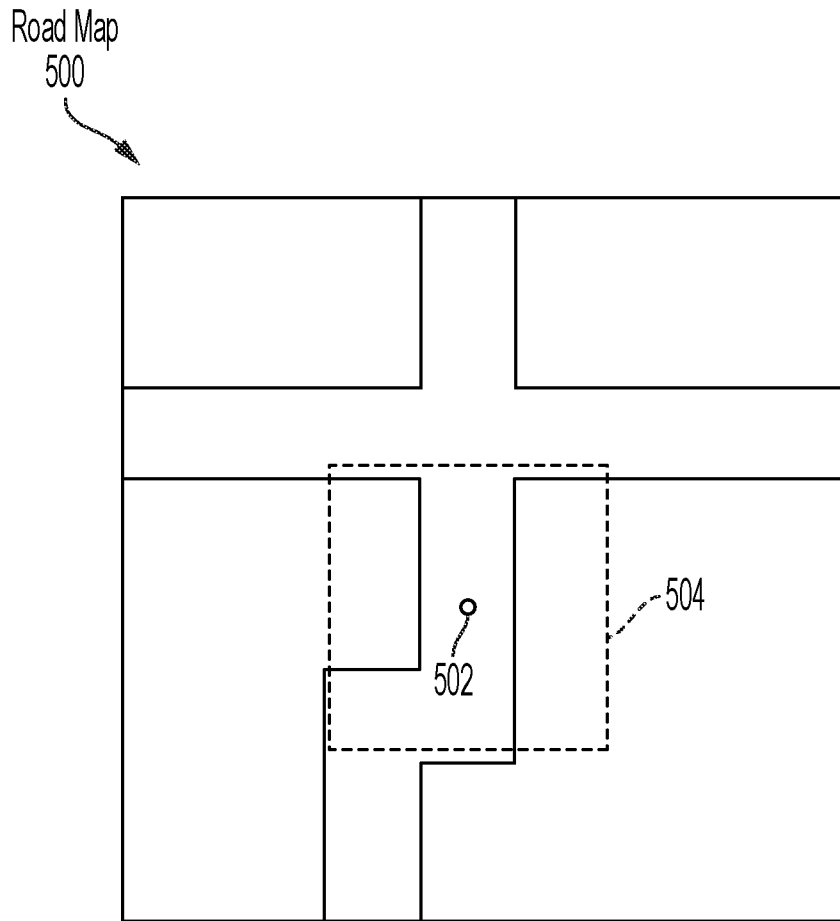

FIG. 5

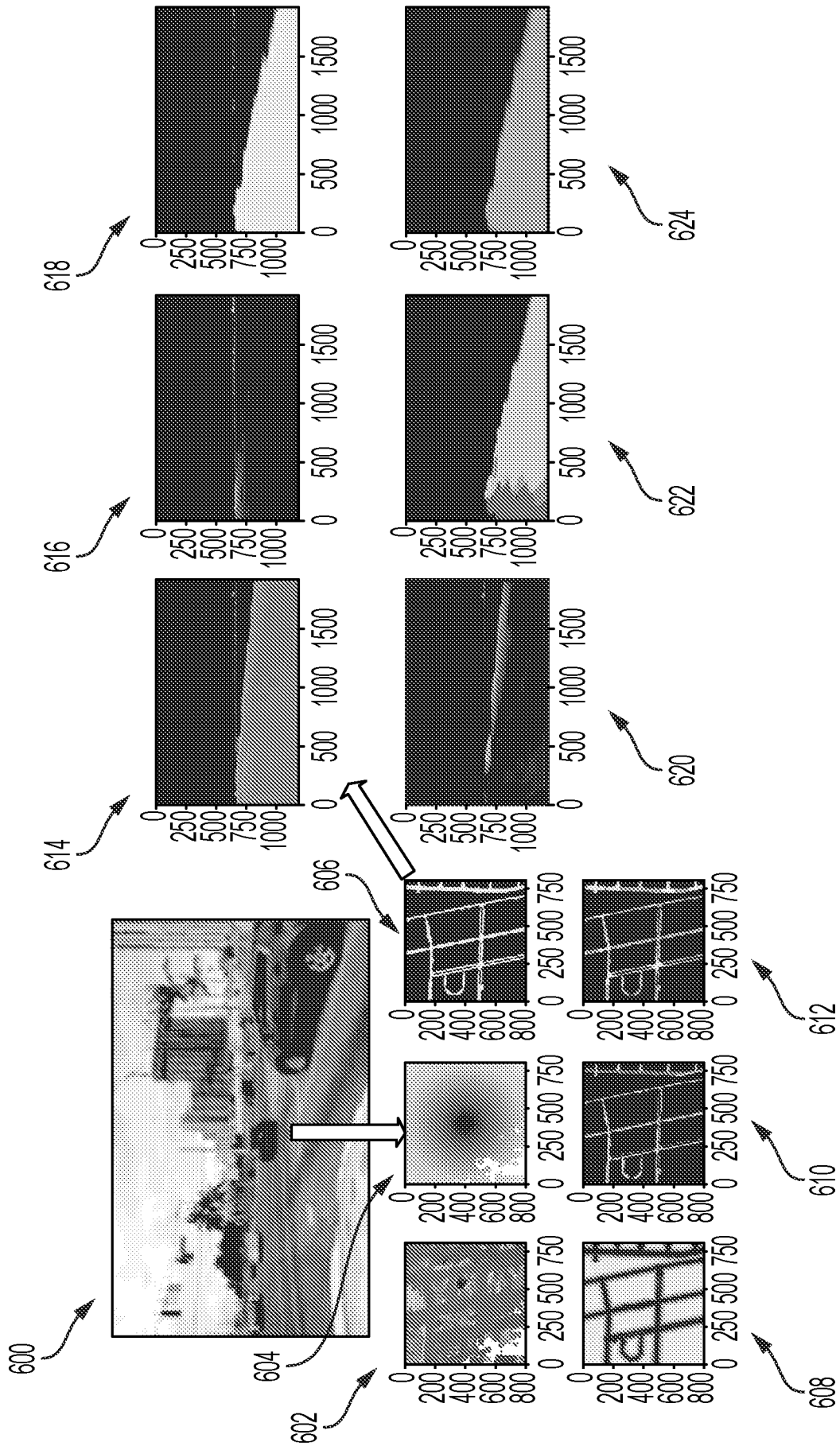

FIG. 6

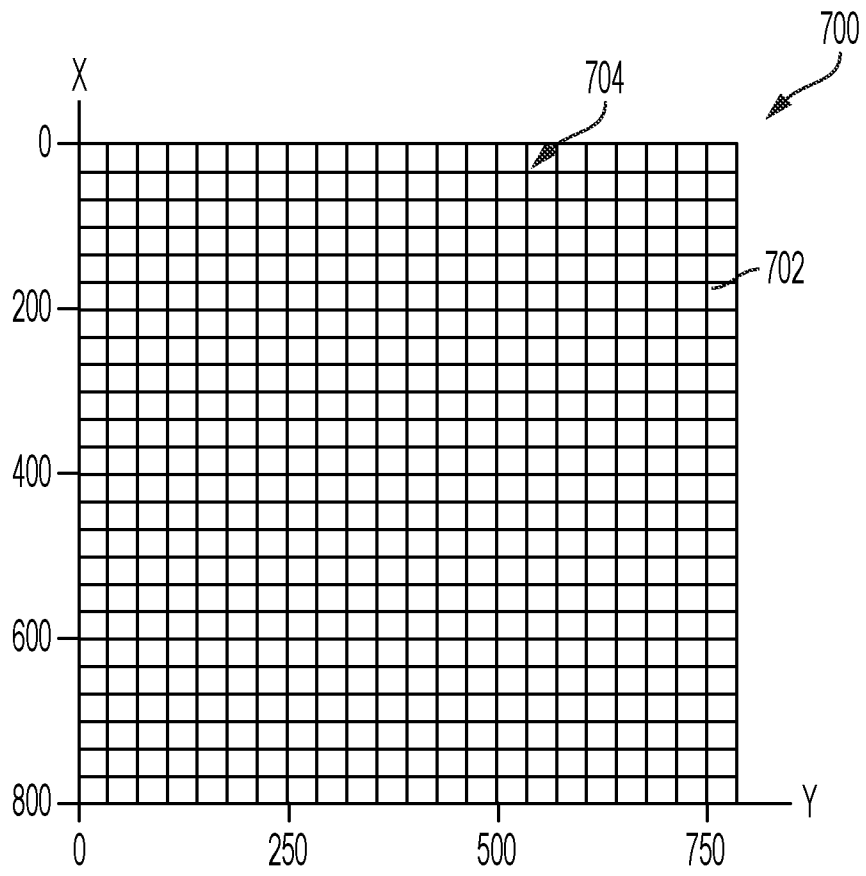

FIG. 7

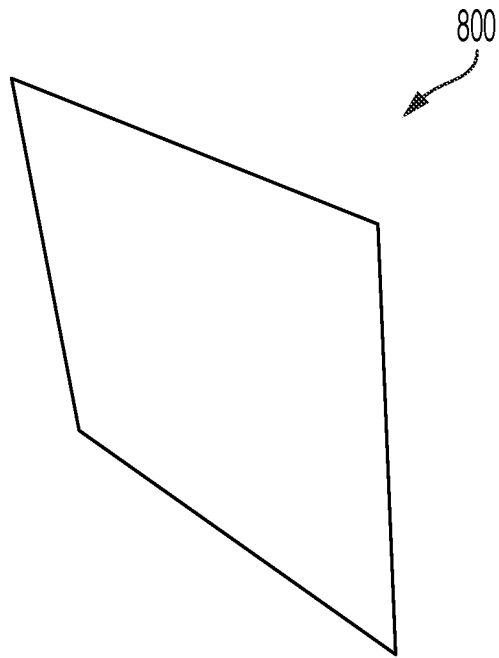

FIG. 8



900  
↘

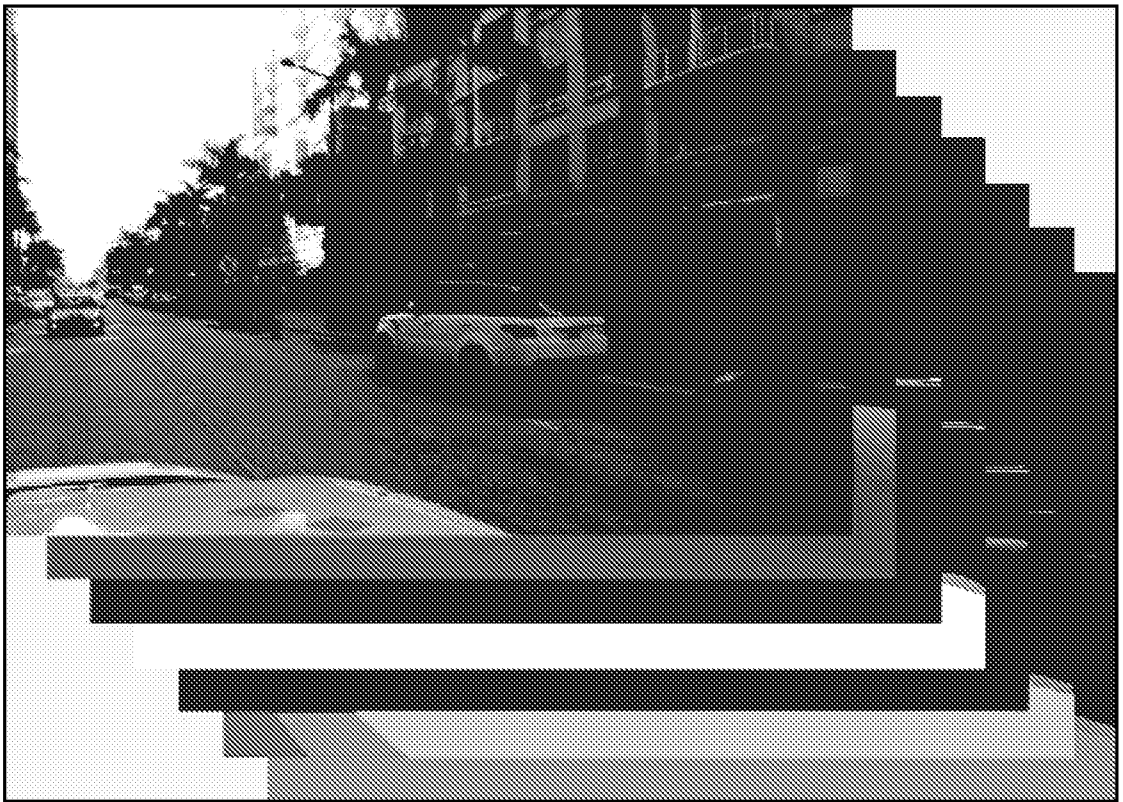

FIG. 9

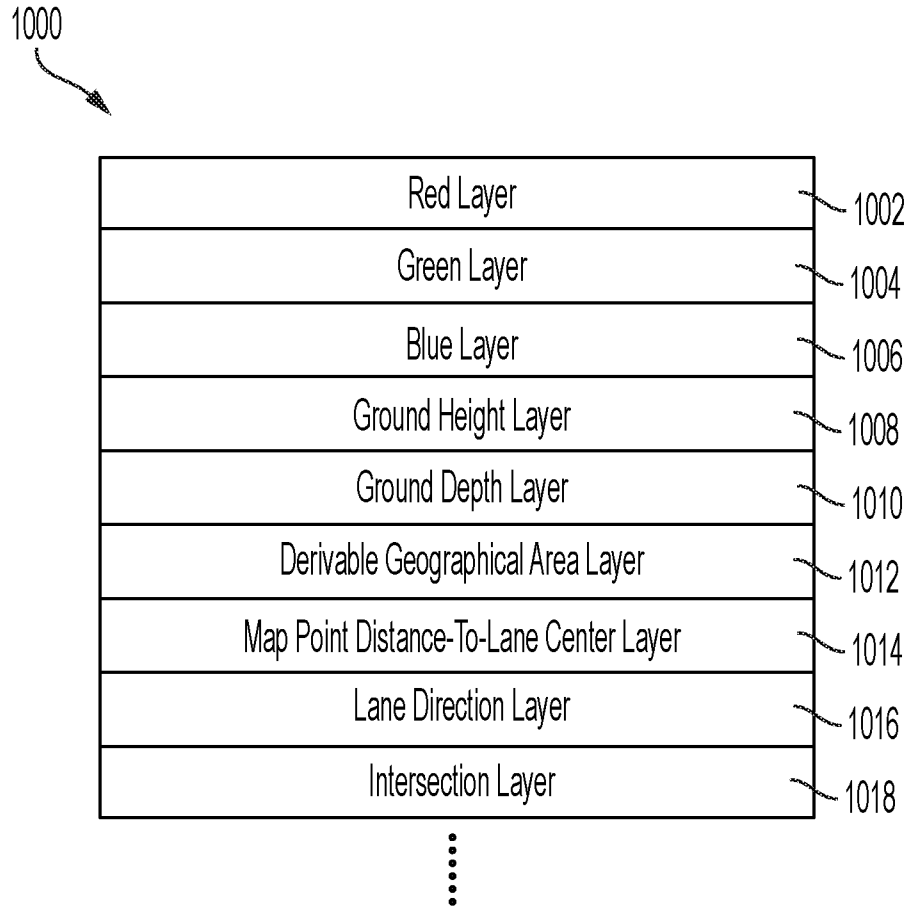

FIG. 10

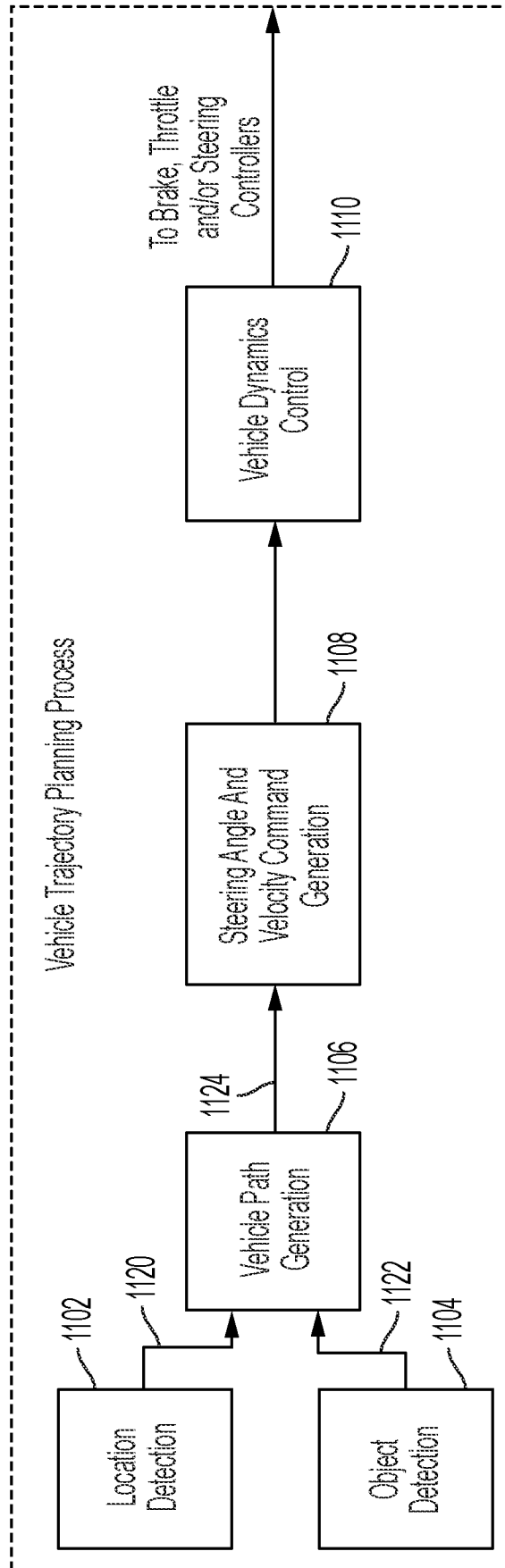

FIG. 11

## INTERNATIONAL SEARCH REPORT

International application No.

PCT/US2021/057905

<b>A. CLASSIFICATION OF SUBJECT MATTER</b> IPC (20210101) G06T 19/00, G01C 21/36, G06K 9/00 CPC (20161101) G06T 19/006, G01C 21/3647, G06K 9/00805 According to International Patent Classification (IPC) or to both national classification and IPC		
<b>B. FIELDS SEARCHED</b> Minimum documentation searched (classification system followed by classification symbols) IPC (20210101) G06T 19/00, G01C 21/36, G06K 9/00 CPC (20161101) G06T 19/006, G01C 21/3647, G06K 9/00805 Documentation searched other than minimum documentation to the extent that such documents are included in the fields searched Electronic data base consulted during the international search (name of data base and, where practicable, search terms used) Databases consulted: Esp@cenet, Google Patents Search terms used: image and map superimposed layers; vehicle object detection image and map superimposed layers;		
<b>C. DOCUMENTS CONSIDERED TO BE RELEVANT</b>		
Category*	Citation of document, with indication, where appropriate, of the relevant passages	Relevant to claim No.
Y	US 2020132490 A1 PHUAR TECH INC [US] 30 Apr 2020 (2020/04/30) ¶ 19, 41, 43;	1-20
Y	IN 202027039221 A SONY CORPORATION (US) 02 Oct 2020 (2020/10/02)	1-20
<input type="checkbox"/> Further documents are listed in the continuation of Box C. <input checked="" type="checkbox"/> See patent family annex.		
* Special categories of cited documents: "A" document defining the general state of the art which is not considered to be of particular relevance "D" document cited by the applicant in the international application "E" earlier application or patent but published on or after the international filing date "L" document which may throw doubts on priority claim(s) or which is cited to establish the publication date of another citation or other special reason (as specified) "O" document referring to an oral disclosure, use, exhibition or other means "P" document published prior to the international filing date but later than the priority date claimed "T" later document published after the international filing date or priority date and not in conflict with the application but cited to understand the principle or theory underlying the invention "X" document of particular relevance; the claimed invention cannot be considered novel or cannot be considered to involve an inventive step when the document is taken alone "Y" document of particular relevance; the claimed invention cannot be considered to involve an inventive step when the document is combined with one or more other such documents, such combination being obvious to a person skilled in the art "&" document member of the same patent family		
Date of the actual completion of the international search 26 Dec 2021		Date of mailing of the international search report 27 Dec 2021
Name and mailing address of the ISA: Israel Patent Office Technology Park, Bldg.5, Malcha, Jerusalem, 9695101, Israel Email address: pctoffice@justice.gov.il		Authorized officer MARCOWITZ Noam Telephone No. 972-73-3927224

**INTERNATIONAL SEARCH REPORT**  
Information on patent family members

International application No.  
PCT/US2021/057905

Patent document cited search report	Publication date	Patent family member(s)	Publication Date
US 2020132490 A1	30 Apr 2020	US 2020132490 A1	30 Apr 2020
<hr/>			
		US 11156472 B2	26 Oct 2021
		US 10488215 B1	26 Nov 2019
		US 2020378779 A1	03 Dec 2020
		US 11085787 B2	10 Aug 2021
IN 202027039221 A	02 Oct 2020	NONE	
<hr/>			