

(No Model.)

C. F. WIESENMEYER.

HARNESS.

No. 256,087.

Patented Apr. 4, 1882.

Fig. 1.

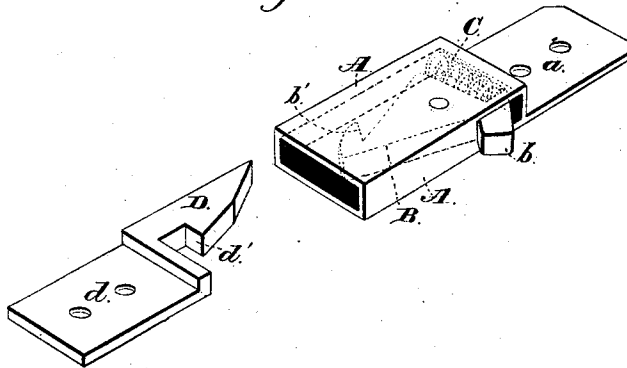
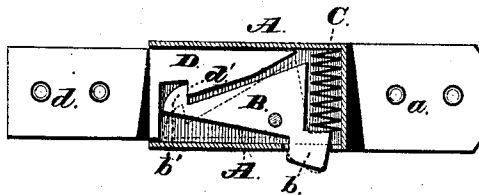

Fig. 2.



Witnesses:

Jas. E. Hutchinson  
Henry L. Hazard

Inventor:

C. F. Wiesenmeyer by  
Geo. S. Prindle his Atty.

# UNITED STATES PATENT OFFICE.

CHARLES F. WIESENMEYER, OF SPRINGFIELD, ILLINOIS.

## HARNESS.

SPECIFICATION forming part of Letters Patent No. 256,087, dated April 4, 1882.

Application filed February 10, 1882. (No model.)

*To all whom it may concern:*

Be it known that I, CHARLES F. WIESENMEYER, of Springfield, in the county of Sangamon, and in the State of Illinois, have invented certain new and useful Improvements in Harness; and I do hereby declare that the following is a full, clear, and exact description thereof, reference being had to the accompanying drawings, making a part of this specification, in which—

Figure 1 is a perspective view of my device, the parts being separated; and Fig. 2 is a longitudinal section of the same as arranged for use, the locking parts being shown in plan view.

Letters of like name and kind refer to like parts in each of the figures.

The design of my invention is to render more easy the placing in and removing from position of the crupper and other parts of a harness; and to this end it consists in the construction and combination of the parts of the device, substantially as and for the purpose hereinafter shown.

In the annexed drawings, A represents a housing having in cross-section substantially the form and dimensions of one of the billets, to which a crupper is attached, and preferably a length equal to about twice its width. At the rear closed end of said housing is provided a tongue, *a*, by means of which the same is connected by rivets, or other means to or with one end of the crupper or with one of the billets.

Within the housing A is provided a latch, B, which has the form shown in Fig. 2, and is pivoted to or within the same near its rear end. From the rear end of said latch a lug, *b*, projects outward through an opening in the edge of said housing, which furnishes a means whereby said latch may be moved and also acts as a stop for limiting the motion of the same. A spring, C, placed within the rear end of said housing bears against the inner edge of said lug and holds said latch with a yielding pressure at the limit of its motion in one direction.

The end of the latch B is provided with a hook, *b'*, which is engaged by a notch, *d'*, that is formed in the edge of a bar, D, which bar

has such size and shape as to enable it to enter the open end of the housing A at one side of said latch, as shown in Fig. 2. The edge of the bar D adjacent to the latch B is formed upon a diagonal line, so as to give to the end of said bar a pointed form and enable it, when inserted within the housing A, to press the hooked end of said latch aside. When said bar has passed inward until its notch *d* coincides with the hook *b'* the latter automatically engages therewith and securely locks said bar in place. To release said bar D it is only necessary that the lug *b* be pressed rearward, when said latch will assume the position shown by dotted lines of Fig. 2, said hook *b'* being thereby withdrawn from engagement with said notch.

The outer end of the bar D is provided with a tongue, *d*, similar in size and shape to the like features of the tongue *a*, by means of which said bar may be connected to or with one of the crupper or back-band billets.

As thus constructed the device furnishes a means for connecting a crupper to or with a back-band and for rendering easy the attachment or detachment of said crupper during the operation of placing in or removing from position a harness.

While preferably used in connection with a crupper, it will be obvious that this device may be employed for connecting together any portions of a harness.

Having thus fully set forth the nature and merits of my invention, what I claim as new is—

The hereinbefore-described device, in which the housing A, provided with the tongue *a*, the latch B, having the lug *b* and hooked end *b'*, the spring C, and the bar D, provided with the notch *d'* and tongue *d*, are constructed and combined to operate in the manner and for the purpose substantially as shown.

In testimony that I claim the foregoing I have hereunto set my hand this 26th day of November, 1881.

C. F. WIESENMEYER.

Witnesses:

L. H. BRADLEY,  
S. HAMMERSLOUGH.