

(19) World Intellectual Property  
Organization  
International Bureau



(43) International Publication Date  
17 November 2005 (17.11.2005)

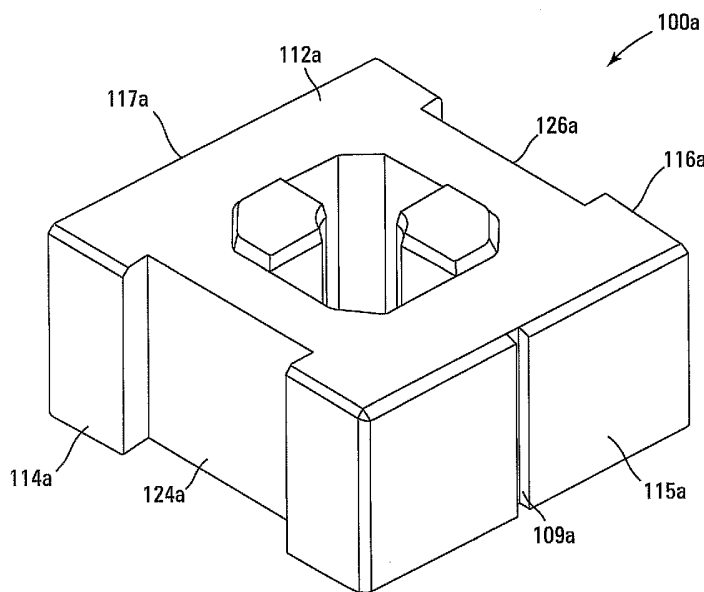
PCT

(10) International Publication Number  
**WO 2005/108702 A1**

- (51) International Patent Classification<sup>7</sup>: **E04C 1/39**, E04H 17/14
- (74) Agents: **WILES, Terry** et al.; Popovich, Wiles & O'Connell, P.A., 650 Third Avenue South, Suite 600, Minneapolis, MN 55402-1911 (US).
- (21) International Application Number: PCT/US2005/014676
- (81) Designated States (unless otherwise indicated, for every kind of national protection available): AE, AG, AL, AM, AT, AU, AZ, BA, BB, BG, BR, BW, BY, BZ, CA, CH, CN, CO, CR, CU, CZ, DE, DK, DM, DZ, EC, EE, EG, ES, FI, GB, GD, GE, GH, GM, HR, HU, ID, IL, IN, IS, JP, KE, KG, KM, KP, KR, KZ, LC, LK, LR, LS, LT, LU, LV, MA, MD, MG, MK, MN, MW, MX, MZ, NA, NI, NO, NZ, OM, PG, PH, PL, PT, RO, RU, SC, SD, SE, SG, SK, SL, SM, SY, TJ, TM, TN, TR, TT, TZ, UA, UG, US, UZ, VC, VN, YU, ZA, ZM, ZW.
- (22) International Filing Date: 28 April 2005 (28.04.2005)
- (25) Filing Language: English
- (26) Publication Language: English
- (30) Priority Data: 60/566,590 29 April 2004 (29.04.2004) US
- (71) Applicant (for all designated States except US): **KEYSTONE RETAINING WALL SYSTEMS, INC.** [US/US]; 4444 West 78th Street, Bloomington, MN 55435 (US).
- (84) Designated States (unless otherwise indicated, for every kind of regional protection available): ARIPO (BW, GH, GM, KE, LS, MW, MZ, NA, SD, SL, SZ, TZ, UG, ZM, ZW), Eurasian (AM, AZ, BY, KG, KZ, MD, RU, TJ, TM), European (AT, BE, BG, CH, CY, CZ, DE, DK, EE, ES, FI, FR, GB, GR, HU, IE, IS, IT, LT, LU, MC, NL, PL, PT, RO, SE, SI, SK, TR), OAPI (BF, BJ, CF, CG, CI, CM, GA, GN, GQ, GW, ML, MR, NE, SN, TD, TG).
- (72) Inventors: **MACDONALD, Robert**; 2310 Quinwood Lane North, Plymouth, MN 55441 (US). **DAWSON, William**; 320 Lythrum Lane, Medina, MN 55340 (US).

[Continued on next page]

(54) Title: COLUMNAR BLOCK FENCE SYSTEM



(57) Abstract: A system of columnar blocks and stacking blocks interlock with each other in the construction of a pilaster or column and a fence panel, respectively, for use in a fence. The columnar blocks are generally square and the stacking blocks are generally rectangular. The columnar block faces may contain one or more slots to give a column an appearance of a masonry joint. Blocks have at least one interlocking element that permits a positive connection between courses of the blocks when the interlocking element is received in an overlying block.

WO 2005/108702 A1



**Published:**

- *with international search report*
- *before the expiration of the time limit for amending the claims and to be republished in the event of receipt of amendments*

*For two-letter codes and other abbreviations, refer to the "Guidance Notes on Codes and Abbreviations" appearing at the beginning of each regular issue of the PCT Gazette.*

A need in this art remains for blocks that can be used to construct mortarless, sturdy, reinforceable columns that have a desired appearance.

#### Summary of the Invention

5           This invention is a system of columnar blocks and stacking blocks configured to interlock with each other in the construction of fence panels and of a pilaster or column, respectively, in a fence. The columnar blocks are generally square and the stacking blocks are generally rectangular. The columnar blocks may be configured to be used with from one to four fence  
10 panels. Any exposed face of the blocks (i.e., that face visible to a viewer) preferably has a desired appearance, such as that resembling natural stone, or smooth to give a more formal appearance. The faces of the columnar blocks may contain one or more slots to give the resulting column or pilaster a more aesthetic appearance, such as that of a masonry joint. The appearance of the  
15 columnar block faces that interlock with fence panels may be smooth or textured to match the column finish.

          The columnar blocks are provided with at least one interlocking element that permits a positive connection between courses of the blocks when the interlocking element is received in an overlying block. In one embodiment, the  
20 blocks interlock when there is a 90 degree rotation about a vertical axis of each block with each course. Also, these blocks may be placed over a pipe that is anchored into the ground. The core and the interlocking elements may be shaped to accommodate such a pipe. The columnar blocks can be used to construct a column with a natural stone-like appearance or smooth appearance  
25 depending upon which type of block is used. This building block system is designed to be easy to install and structurally sound.

          When asymmetrical columnar blocks are used, such as in a corner of a wall, the location of the projections is varied so that there is a 'left-hand' and

'right-hand' block, and the projections of a 'left-hand' block will interlock into the core or void of the overlying 'right-hand' block.

The sides of the columnar block are provided with recesses into which fit the stacking blocks. The resulting block system is easy to install and  
5 structurally sound. The interlocking system makes the use of construction adhesive and other forms of mortar unnecessary, though such may still be used.

#### Brief Description of the Drawings

- FIG. 1 is a perspective view of a columnar block according to this invention.
- 10 FIG. 2A is a side view, FIG. 2B is a top view, and FIG. 2C is a bottom view, respectively, of the columnar block of FIG. 1.
- FIG. 3 is a perspective view of a columnar block according to this invention.
- FIG. 4 is a view of the columnar block of FIG. 1 having a vertical reinforcement element.
- 15 FIG. 5 is a view of an alternate embodiment of the columnar block according to this invention.
- FIGS. 6 and 7 are perspective views of other embodiments of a building block of this invention.
- FIGS. 8A is a side view of the block of FIG. 7.
- 20 FIG. 9A is a top view of the block of FIG. 7.
- FIG. 9B is a top view of another embodiment of the block of this invention.
- FIG. 10A is a bottom view of the block of FIG. 7.
- FIG. 10B is a bottom view of the block of FIG. 9B.
- FIG. 11 is a partial perspective view of a corner section of a wall formed with  
25 stacking blocks and the blocks of FIGS. 9A and 9B.
- FIGS. 12 and 13 are perspective views of other embodiments of the building block of this invention.
- FIGS. 14A and 14B are top and bottom views, respectively, of the block of FIG. 13.

FIG. 15 is a perspective view of another embodiment of a building block of this invention.

FIG. 16 is a perspective view of a column of blocks of FIG. 15.

FIG. 17 is a top view of the block of FIG. 15 and interlocking stacking blocks.

5 FIG. 18 is a perspective view of another embodiment of a building block of this invention.

FIG. 19A is a top view and FIG. 19B is a side view of the block of FIG. 18.

FIG. 20A is a perspective view, FIG. 20B is an end view, and FIG. 20C is a top view of a first stacking block of this invention.

10 FIG. 21A is a perspective view, FIG. 21B is an end view, and FIG. 21C is a top view of a second stacking block of this invention.

FIGS. 22 and 23 are partial perspective views of fence systems of this invention.

FIG. 24 is a cross-sectional view of a fence of this invention.

15 FIGS. 25A to 25D are end views of capping layers.

#### Detailed Description of the Preferred Embodiments

In this application, “upper” and “lower” refer to the placement of a columnar block in a column and a stacking block in a fence panel. The lower or bottom surface of blocks is the surface that faces the ground. Subsequent courses are formed by stacking blocks so that an interlocking element, projection, or “tongue” from one block fits into an indentation, void, or “groove” of an overlying block. “Top” and “bottom” surfaces are defined as those most conventionally used for these blocks, however, the blocks can be used with tops and bottom reversed.

20

25

The blocks of this invention may be made of a rugged, weather resistant material, such as concrete, especially if the columnar structure is constructed outdoors. Other suitable materials include plastic, reinforced fibers such as fiberglass, wood, metal and stone. Rather than being formed of a solid mass of

material, the blocks may be hollow. That is, the blocks have the desired dimension, texture, and characteristics, but are hollow shells. This is an advantage in saving materials and in handling the block. Such hollow shell blocks can be formed of urethane or concrete and by casting techniques.

5           The surface of the blocks may be smooth or may have a roughened appearance, such as that of natural stone. The blocks are formed in molds and various textures can be formed on the surface, as is known in the art.

          In typical use, the interlocking element extends above the top surface of the columnar block and projects into an indentation in an overlying block. In a  
10 preferred embodiment, the indentation is the same as the core; that is, the core extends through the thickness of the block. In one preferred embodiment, two interlocking elements extend above the top surface of the columnar block into the core of the overlying block, thus producing positive interconnection  
15 between facing surfaces. In a preferred embodiment, each successive block is rotated by 90 degrees about its vertical axis thus causing the interlocking elements to project into the indentation or core of the block above it. The interlocking elements hold the columnar blocks in place and eliminate the need for mortar when constructing the column.

          For columnar blocks having a vertical axis of symmetry, the overlying  
20 block is rotated about its vertical axis and placed on the underlying block. The projections thus fit into the void created by the core. For columnar blocks that are asymmetrical, such as for a corner fence column, the blocks are not rotated as they are stacked, but rather, 'left-hand' and 'right-hand' blocks are provided, as described further below.

25           The faces of the blocks visible to a viewer are provided with a desirable surface appearance. These can be textured in a manner resulting in an appearance similar to that of natural stone, or can be smooth to give a more formal appearance. All four faces of the columnar block have substantially the same width and height. One or more faces of the columnar block optionally

may contain one or more slots that will be visible in the columnar structure to give a column of blocks a more aesthetic appearance. This appearance may mimic mortared blocks, for example.

Rotation of each columnar block about its vertical axis also varies the  
5 location of the slot, if present, resulting in a more eye-pleasing pattern for the column. Rotation of the columnar blocks as a column is built also serves to produce a straight column. Because block molding processes may result in uneven blocks, stacking the blocks all in the same orientation may cause a column to tilt or lean. This problem is usually solved by shimming the blocks  
10 to make them level. With the column blocks of this invention, shimming is unnecessary.

The columnar block is provided with one or more recesses in one or more sides of the block. This recess is sized to accommodate an end of a stacking block. The column blocks and stacking blocks together form a system  
15 of blocks that forms a fence. Depending on the location of the recesses, a straight section, a corner section, a T-intersection, or a universal cross column can be constructed. The recesses in the columnar block optionally are provided with a passageway or channel. In this way, horizontal reinforcement can be used, if desired, to tie in a layer of stacking blocks to a columnar block in a  
20 column.

The stacking blocks form fence sections. Suitable stacking blocks are described in U.S. Patent No. 6,176,049 (Crant et al.), hereby incorporated herein by reference. The stacking blocks have opposing top and bottom surfaces that have corresponding channels and projections so that the blocks  
25 interlock when stacked.

Columnar blocks of this invention also may be used with other blocks having interlocking elements, such as those described in commonly assigned, co-pending U.S. application Serial No. \_\_\_\_\_ entitled "Column Block System," filed on even date herewith (Attorney Docket Number KEY1033US),

which claims the benefit of commonly assigned, co-pending U.S. Provisional application Serial No. 60/566,528, filed April 29, 2004 entitled "Column Block System," both of which applications are hereby incorporated herein by reference.

5 Both vertically and horizontally interlocking fence systems can be constructed with the blocks of this invention.

Turning now to the drawings, the blocks of this invention are described. FIGS. 1 and 2 show columnar block 100a. FIG. 3 shows columnar block 100b, which is identical to block 100a except for the placement of interlocking  
10 elements 122a/b. FIG. 5 shows block 100c, which is similar to blocks 100a and 100b, except that channels are added to provide for horizontal reinforcement. The columnar blocks will be referred to generically as block 100.

Blocks 100 comprise top or upper surface 112a/b/c, bottom or lower  
15 surface 113 a/b/c, first and second opposed sides 114 a/b/c and 116 a/b/c, and third and fourth opposed sides 115 a/b/c and 117 a/b/c. Top surface 112 a/b/c is spaced apart from opposing lower surface 113 a/b/c, thereby defining a block thickness. Opposed sides are substantially the same in width and height. The top and bottom surfaces 112 a/b/c, 113 a/b/c together with the first through  
20 fourth sides 114 a/b/c to 117 a/b/c form block body 100 a/b/c.

The sides are provided with a desired appearance, as they will be visible to a viewer. Side 115a/b/c is additionally provided with trough or slot 109a/b/c. This slot is optional and is a decorative feature. The slot mimics the appearance of a mortar joint when a column of blocks is constructed. Sides  
25 114 a/b/c and 116 a/b/c have recessed areas 124 a/b/c and 126 a/b/c, respectively, located generally centrally on each block side, and suitable for interlocking with a fence panel and/or stacking block as described further below.



The blocks are provided with core 120 a/b/c, preferably located in the center of the block, which extends the thickness of the block. A core is desirable because it results in reduced weight for the block. The core is also useful when forming a column because vertical reinforcement can be inserted  
5 through the vertically aligned cores to lend stability to the columnar structure. For example, concrete grout and rebar, steel pipe, or post-tension rods can be used to fill the core and strengthen the structure. Various reinforcement materials are known in the art.

Block 100c, shown in FIG. 5, has recesses 124c and 126c that  
10 communicate with core 120c via passageways or channels 129c. The channel is a U-shaped depression which permits horizontal reinforcement to be used when joining a stacking block to a column of blocks. This is described further below.

The surfaces of the block meet to form edges and corners. The corners  
15 may be beveled, chamfered or rounded to give a more weathered natural stone-like appearance.

Core 120a/b/c is generally rectilinear, having walls generally parallel to the side surfaces. On opposing inside corners of core 120 a/b/c are located two interlocking elements 122 a/b/c. These elements extend the thickness of the  
20 block, and project above the top surface of the block. They are essentially co-planar or parallel with the bottom surface of the block, that is, the bottom surface of the block is essentially co-planar or contiguous with the bottom surfaces of these elements. Although neither the interlocking elements nor the core need extend the thickness of the block, typically it is simpler to  
25 manufacture the blocks this way. In any event, the interlocking elements extend a distance above the top surface of the block. This distance is sufficient to provide adequate interlocking between blocks when a second columnar block is stacked on a first columnar block.

The interlocking elements are positioned both to align columnar blocks and lock them into place when they are stacked one upon another. That is, blocks 100a and 100b would be used together in a column. The position of the interlocking elements varies so that the columnar blocks can be stacked. Block  
5 100c might be interlocked with corresponding similar columnar blocks (i.e., analogous to blocks 100b); however, block 100c can be used with blocks 100a and 100b in a column of blocks and horizontal reinforcement used in only one layer of the column.

In preferred embodiments, the interlocking elements are shaped so that a  
10 pipe connecting the column to its base or foundation can be installed vertically in the center of the columnar block and through the center of the column. That is, as shown in the figures, the portion of the projection facing the center of the core is curvilinear.

FIG. 4 illustrates block 100b having vertical reinforcement member 50.  
15 This reinforcement member, or pipe, can be made of galvanized steel, and a column of blocks is formed around it when constructing a fence, as described further below. Reinforcement member 50 is tied to a column foundation (e.g., in-ground molded concrete) by means of direct embedment or by use of a threaded sleeve which connects to a mating thread at the end of the steel tube.

FIGS. 6 to 11 illustrate columnar blocks 200a and 200b of this  
20 invention. Block 200a/b is similar to block 100a/b, except that adjacent sides, rather than opposing sides, are similar. That is, for example, adjacent sides 214a/b and 215a/b have recessed areas 224a/b and 225a/b. This block is for use at a corner of a fence. Block 200a is similar to block 200b except that  
25 recesses 224b and 225b of block 200b are provided with channels for use with horizontal reinforcement.

Blocks 200a/b comprise top or upper surface 212a/b, bottom or lower surface 213a/b (213a not shown), first and second opposed sides 214a/b and 216a/b, and third and fourth opposed sides 215a/b and 217a/b. Top surface

212a/b is spaced apart from opposing lower surface 213a/b, thereby defining a block thickness. Opposed sides have substantially the same height and width. The top and bottom surfaces together with the first, second, third, and fourth sides form a block body.

5 Sides 216a/b and 217a/b are provided with a desired appearance, as they will be visible to a viewer. Side 217a/b is additionally provided with optional trough or slot 209a/b. The blocks are provided with core 220a/b, preferably located in the center of the block, which extends the thickness of the block.

Block 200b, shown in FIG. 7, illustrates that recesses 224b and 225b  
10 communicate with core 220b via U-shaped channels 229b. Side 217b is shown in FIG. 8. The edges and corners of blocks 200a/b are chamfered.

On opposing inside corners of core 220a/b are located two interlocking elements 222a/b. These elements extend the thickness of the columnar block, project above the top surface of the block, and are essentially co-planar with  
15 the bottom surface of the block.

Top 212b of block 200b is shown in FIG. 9A. This is to be contrasted with top 212c of block 200c in FIG. 9B, which has identical features to block 200b. Corresponding bottom views (i.e., 213b and 213c) are shown in FIGS. 10A and 10B. These columnar blocks differ in the placement of the  
20 interlocking projections. These columnar blocks can be considered left-hand and right-hand blocks, as illustrated in FIG. 11, in which the corner of a partial wall is shown with a first course of stacking blocks 700. In this case, block 200b is set down first, then block 200c is placed on top of that. Interlocking projections 222b fit into the void created by the core of block 200c. As many  
25 columnar blocks as desired are stacked and interlocked in this manner. Stacking blocks 700 fit into the recesses in the columnar blocks' sides to form fence sections. Both vertical and horizontal reinforcement can be added.

FIGS. 12 and 13 illustrate perspective views of two other columnar block embodiments. Blocks 300a and 300b are similar, each having a recess

on each side of the block. Block 300b additionally has channels 329b coincident with the recesses to accommodate horizontal reinforcement. These columnar blocks are for use in a universal cross column.

Block 300a/b comprises top or upper surface 312a/b, bottom or lower surface 313, first and second opposed sides 314a/b and 316a/b, and third and fourth opposed sides 315a/b and 317a/b. Top surface 312a/b is spaced apart from opposing lower surface 313, thereby defining a block thickness. The opposed sides have substantially the same height and width and each side has corresponding recessed areas 324a/b, 325a/b, 326a/b, and 327a/b. The top and bottom together with the first, second, third, and fourth sides form a block body.

Core 320a/b extends the thickness of the columnar block as shown in the bottom view of FIG. 14A. The top view of block 300b is shown in FIG. 14B. Core 320a/b is generally rectilinear, having walls generally parallel to the side surfaces. On opposing inside corners of core 320a/b are located two projections or interlocking elements 322a/b, which project above the top surface of the block.

Block 400 is shown in FIGS. 15 to 17. This columnar block is similar to block 100b, except that a portion of the block has been removed to form side void 429. The side voids are generally larger in area, though similar in function to, the U-shaped channels of block 100b. The creation of a larger space through the columnar block is more desirable for some types of horizontal reinforcement.

Block 400 comprises top or upper surface 412, bottom or lower surface 413, first and second opposed sides 414 and 416, and third and fourth opposed sides 415 and 417. Top surface 412 is spaced apart from opposing lower surface 413, thereby defining a block thickness. Opposed sides have substantially the same width.

Optional slot 409 is located at a midpoint on side 415. The slot results in a desirable appearance of the columnar blocks, mimicking that of mortared blocks, and it aids in positioning the columnar block when forming a column.

Core 420 extends the thickness of the block. Core 420 is generally  
5 rectilinear, having walls generally parallel to the side surfaces. On opposing inside corners of core 420 are located two interlocking elements or projections 422. These elements extend the thickness of the block, and project above the top surface of the block. The bottom surface of the columnar block is essentially co-planar or contiguous with the bottom surfaces of these elements.

10 FIG. 16 shows column 475 of blocks 400. Side voids 429 provide a passageway through the columnar blocks. It should be noted that one block 400 could be used with several blocks 100, for example, when it is desired to reinforce a column horizontally through one course. FIG. 17 is a top view of one course of fence with a column formed from block 400. Vertical  
15 reinforcing member 50 is placed in the center of block 400. Stacking blocks 700 interlock with and extend away from columnar block 400.

FIGS. 18 and 19 illustrate block 500, which is provided with multiple cores. That is, not only is there the central block core 520, but there are additional cores in the interlocking projections and at the corners of the block.  
20 Block 500 is similar to block 100a, in that it has recessed areas on opposing surfaces and substantially the same profile as block 100a. The presence of additional cores reduces the weight of the columnar block. This is desirable if the blocks are formed from a dense material, such as concrete, but is also useful if the block is molded from polymeric material, for example.

25 Block 500 has upper surface 512, lower surface 513, first and second opposed sides 514 and 516, and third and fourth opposed sides 515 and 517. Opposed sides are substantially the same in width and height. Side 515 has optional slot 509. Sides 514 and 516 have recessed areas 524 and 526,

respectively, located generally centrally on each block side. The top and side edges of the block are chamfered.

Core 520 is located in the center of the block and extends the thickness of the block. Core 520 is generally rectilinear, having walls generally parallel to the side surfaces. On opposing inside corners of core 520 are located two interlocking elements 522, each having core 532. Adjacent each block corner is core 534. The cores can be seen in the top view in FIG. 19A and in phantom in the side view of FIG. 19B.

The columnar blocks of this invention can be manufactured to any desired dimension. Typically, the thickness or height is about half the width of the columnar block. A desirable size for the columnar blocks is about 12 inches (30.4 cm) square (i.e., the maximum distance measured from side to side), and the thickness is about 6 inches (15.2 cm). The depth of the recessed area is about 1 inch (2.5 cm), and its width is about 6 inches (15.2 cm) so that it can accommodate the width of a stacking block. The U-shaped channel typically is about 3 inches (7.6 cm) deep. Block dimensions are selected not only to produce a pleasing shape for the desired column, but also to permit ease of handling and installation.

Two types of stacking blocks are used to construct a panel of a fence. As mentioned above, U.S. Patent No. 6,176,049 (Crant et al.), incorporated herein by reference, describes suitable stacking blocks. A first stacking block is shown in FIGS. 20A to 20C. Block 700 has opposing top and bottom surfaces 704 and 705, opposing side surfaces 706 and 707, and opposing end surfaces 702 and 703. The distance between end surfaces 702 and 703 defines the length of the stacking block. The distance between the side surfaces defines the width, and the distance between the top and bottom defines the thickness of the stacking block. Through the center of the stacking block along the length is core 708 through which is a longitudinal axis. The top surface has channels or grooves 710 adjacent each side surface and the bottom surface has

projections 712 adjacent each side surface. When stacked, the projections on the bottom surface of a stacking block fit in the channels in the top surface of an underlying stacking block. Thus, these stacking blocks interlock. The interlocking eliminates any need for mortar to join the hollow stacking blocks  
5 700 together.

It is to be understood that the designations "top block" or "bottom block" is arbitrary and that the blocks could be stacked in the opposite orientation.

Block edges may be chamfered or beveled to provide an attractive  
10 appearance, and preferably the edge formed by the channel or groove in the top surface with the side surface is chamfered.

FIGS. 21A to 21C illustrate a second stacking block, which has substantially the same dimensions as the stacking block shown in FIGS. 20A to 20C. Block 800 has opposing top and bottom surfaces 804 and 805, opposing  
15 side surfaces 806 and 808, and opposing end surfaces 802 and 803. The distance between end surfaces 802 and 803 defines the length of the block. The distance between the side surfaces defines the width, and the distance between the top and bottom defines the thickness of the stacking block. Through the center of the block along the length is cavity 809 coincident with a  
20 longitudinal axis. The cavity opens onto the top surface. The top surface has channels or grooves 810 adjacent each side surface and the bottom surface has projections 812 adjacent each side surface. When stacked, the projections on the bottom surface of a stacking block fit in the channels in the top surface of underlying block 700.

25 Stacking blocks 700 and 800 can be made in any desired dimensions, however, a convenient and attractive size for these blocks is about 6 inches (15.2 cm) wide and high, and 8 inches (20.3 cm) long. The core is about 3.5 inches (8.9 cm) in diameter. The U-shaped channel of block 800 is about 3.5 inches (8.9 cm) wide (i.e., as measured on a line perpendicular to the

longitudinal axis). The channels and the projections are about 1 inch (2.5 cm) wide.

FIG. 22 shows a portion of fence 900 having fence segments 905 and columns 910 and 912. Blocks 100 and 200 form the columns and blocks 700 and 800 form the fence segments. The columns are formed on concrete bases or foundations (shown as 901), which typically comprise concrete and range in diameter from 18 to 24 inches (45.7 to 61 cm). Any desired size may be used to support greater horizontal and vertical loads. The base may be formed by using a tubular form or mold or by other methods as are known in the art.

Base 901 is set into the ground to at least 24 inches (61 cm) or to frost depth depending on engineering requirements and local government building codes. For example, to construct column 910, block 200b (a left hand block, such as shown in FIG. 9A), is set in place, and then block 200c (a right hand block) is set down on top of that. For column 912, the first column block (such as 100b) is set down and each subsequent block is rotated 90 degrees about the vertical axis and stacked upon a lower block. Thus the interlocking projections on the upper surface of a columnar block below fit into the core of a block above and lock the blocks together.

At the top of the fence is a capping layer comprising capping blocks 902. Various capping blocks are suitable for use in construction of a fence and are shown in FIGS. 25A to 25D. The capping blocks cover the open areas of the blocks and provide a finished appearance to the fence.

FIG. 23 shows a portion of fence 920 having columns 930 comprising blocks 300a and 300b and columns 940 comprising blocks 200a and 200b. The topmost block of each column is 300b and 200b, respectively, in order to allow for horizontal reinforcement with the top blocks of the fence panel. The fence segments 925 are at right angles. Each column is formed on base 901. The fence will be finished with a capping layer, such as those shown in FIGS. 25A to 25D.



FIG. 24 is a cross-sectional view of a fence segment, such as 925 of FIG. 23, which illustrates that both stacking blocks 700 and 800 are used. FIG. 24 illustrates that the fence segment is constructed over a base layer 903, which, along with one block layer, is placed below grade level. This fence segment also shows the capping layer in place, in this case capping block 902a. It frequently is desirable to use horizontal reinforcement, such as rebar 952 and grout or other fill material 954, in the bottom and the top layers of the fence. The horizontal reinforcement helps to produce a unified body of columns and fence segments and to restrain bending of the fence segment between columns or pilasters. Horizontal reinforcement is also used at and below grade level. This helps transfer loads to the column and column footings. The reinforcement at grade level allows the fence segment to bridge over soft, potentially settling soils. The top and bottom reinforcement together lock the fence segment blocks together and help resist individual block movement.

Stacking block 800 preferably is used in the same course as a columnar block having a side void (block 400) or a columnar block such as 100b, 200b, or 300b, depending upon the fence configuration. Stacking block 700 can be used with any columnar block, but typically would be used with blocks 100a, 200a, 300a, or 500.

FIGS. 25A to 25D illustrate various styles of capping blocks 902a to 902d each of which have recessed areas 904a to 904d, respectively, to fit over underlying blocks. The capping blocks may be provided in various lengths, typically of a size convenient to handle. The style of capping layer is a matter of design choice. Typically, several capping blocks will be used to form a capping layer across the top of the fence. The capping layers may be made of any material, including wood, concrete, and polymeric materials.

Although particular embodiments have been disclosed herein in detail, this has been done for purposes of illustration only, and is not intended to be limiting with respect to the scope of the claims. In particular, it is

contemplated that various substitutions, alterations and modifications may be made to the invention without departing from the spirit and scope of the invention as defined by the claims. For instance, the choice of materials or variations in the shape or angles at which some of the surfaces intersect are  
5 believed to be a matter of routine for a person of ordinary skill in the art with knowledge of the embodiments disclosed herein.

What is claimed is:

1. A block system for constructing a column with a wall extending therefrom comprising:

5 a plurality of column blocks for forming a column, the column blocks having an upper surface spaced apart from an opposed lower surface, thereby defining a column block thickness, opposed first and second side surfaces and opposed third and fourth side surfaces extending between the upper and lower surfaces, at least one of the side surfaces having a recessed portion extending  
10 from the top surface to the bottom surface, the upper and lower surfaces together with the side surfaces defining a column block body, at least one projection extending from one of the upper and lower surfaces, at least one indentation extending into the other of the upper and lower surfaces, the at least one projection and the at least one indentation being positioned such that when  
15 the column blocks are stacked one upon another to form a column the at least one projection of a column block in a first course is received in the at least one indentation of a column block in a second adjacent course; and

a plurality of wall blocks for forming a wall extending from the column, the wall blocks having an upper surface spaced apart from an opposed lower  
20 surface, thereby defining a wall block thickness, opposed first and second side surfaces of the wall block extending between the upper and lower surfaces of the wall block, opposed first and second ends of the wall block extending between the upper and lower surfaces of the wall block, the upper and lower surfaces of the wall block together with the first and second side surfaces of the  
25 wall block and the first and second ends of the wall block defining a wall block body, one of the first and second ends of the wall block being sized to be received in a recessed portion of a side surface of a column block.

2. The block system according to claim 1, wherein the column blocks are generally square.
3. The block system according to claim 1, wherein the wall blocks are  
5 generally rectangular.
4. The block system according to claim 1, wherein the column blocks are configured to be used with from one to four fence panels.
- 10 5. The block system according to claim 1, wherein an exposed surface contains at least one slot.
6. The block system according to claim 1, wherein the column blocks are configured so that, when constructing a column, the column block in the first  
15 course is rotated 90 degrees about the vertical axis of the column with respect to the column block in the second adjacent course.
7. The block system according to claim 1, wherein the indentation comprises a core.  
20
8. The block system according to claim 7, wherein the column blocks are configured so that, when constructing the column, vertically aligned cores of the columns are filled with reinforcement.
- 25 9. The block system according to claim 8, wherein the reinforcement is selected from concrete grout and rebar, steel pipe and post-tension rods.
10. The block system according to claim 1, wherein the wall blocks include left-hand and right-hand blocks.

11. The block system according to claim 10, wherein the wall blocks are configured so that, when constructing a corner of the wall, at least one projection on a left-hand block in a first course interlocks into a core of a right-hand block in an adjacent course.

12. A column block for forming a column, the column block comprising:  
an upper surface spaced apart from an opposed lower surface, thereby defining a column block thickness;  
opposed first and second side surfaces and opposed third and fourth side surfaces extending between the upper and lower surfaces, at least one of the side surfaces having a recessed portion extending from the top surface to the bottom surface, the upper and lower surfaces together with the side surfaces defining a column block body;  
at least one projection extending from one of the upper and lower surfaces, at least one indentation extending into the other of the upper and lower surfaces, the at least one projection and the at least one indentation being positioned such that when the column blocks are stacked one upon another to form a column, the at least one projection of a column block in a first course is received in the at least one indentation of a column block in a second adjacent course.

13. The column block according to claim 12 that is generally square.

14. The column block according to claim 12 configured to be used with from one to four fence panels.

15. The column block according to claim 12, wherein an exposed surface contains at least one slot.

16. The column block according to claim 12, wherein each block has at least one interlocking element that permits a positive connection between courses of the blocks when the interlocking element is received in an overlying block.

5

17. The column block according to claim 12, configured so that, when constructing a column, the column block in the first course is rotated 90 degrees about the vertical axis of the column with respect to the column block in the second adjacent course.

10

18. The column block according to claim 12, wherein the indentation comprises a core.

19. The column block according to claim 18, wherein the column blocks are  
15 configured so that, when constructing the column, vertically aligned cores of the columns are filled with reinforcement.

20. The column block according to claim 19, wherein the reinforcement is selected from concrete grout and rebar, steel pipe and post-tension rods.

20

21. The column block according to claim 12 that is generally hollow.

22. A fence, comprising:

at least one column of blocks stacked in vertically aligned courses,  
25 wherein each block has an upper surface spaced apart from an opposed lower surface, thereby defining a column block thickness, opposed first and second side surfaces and opposed third and fourth side surfaces extending between the upper and lower surfaces, at least one of the side surfaces having a recessed portion extending from the top surface to the bottom surface, the upper and

lower surfaces together with the side surfaces defining a column block body, at least one projection extending from one of the upper and lower surfaces, at least one indentation extending into the other of the upper and lower surfaces, the at least one projection and the at least one indentation being positioned such  
5 that, when the column blocks are stacked one upon another to form a column, the at least one projection of a column block in a first course is received in the at least one indentation of a column block in a second adjacent course; and  
at least one fence panel having at least one end, the at least one end being connected to the at least one column.

10

23. The fence according to claim 22, wherein the at least one column of blocks is at least two columns of blocks, wherein the at least one end is at least first and second ends, the first end being connected to a first of the two columns and the second end being connected to a second of the two columns.

15

24. The fence according to claim 22, wherein the column blocks are generally square.

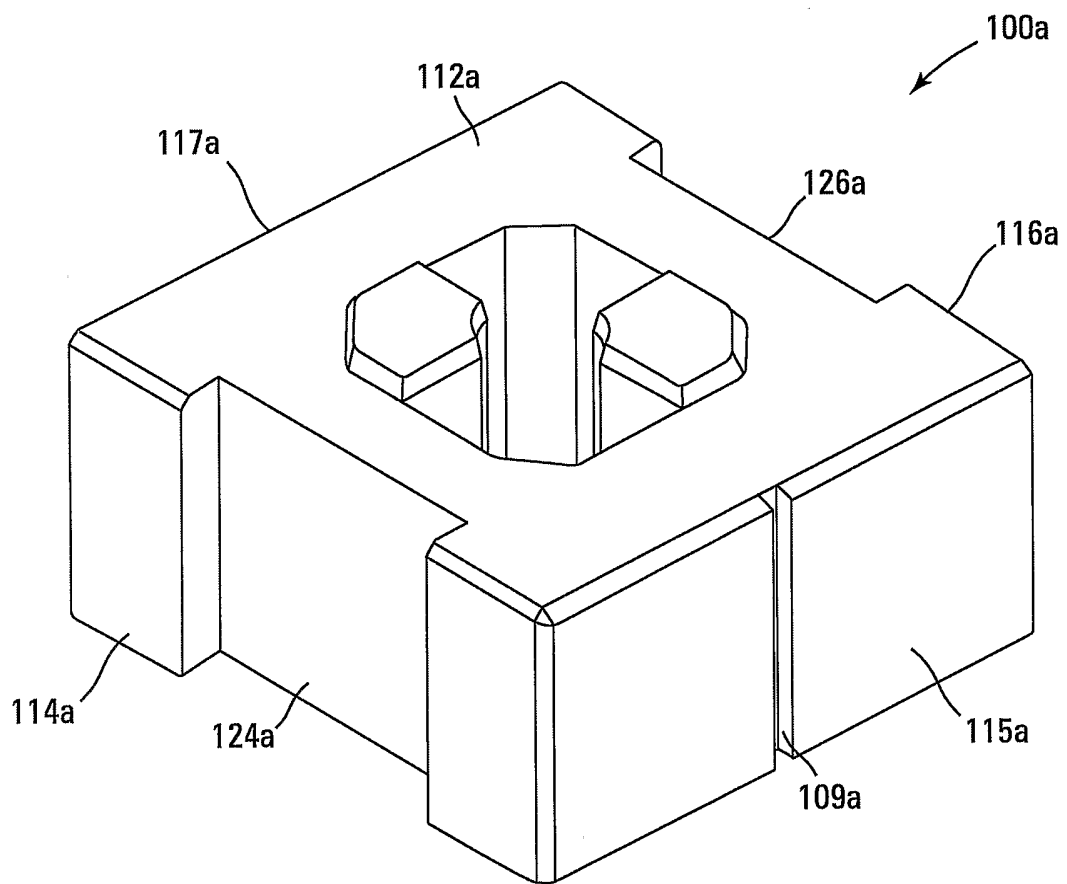
25. The fence according to claim 22, wherein the at least one column is  
20 configured to be used with from one to four fence panels.

26. The fence according to claim 22, wherein the indentation comprises a core.

25 27. The fence of claim 26, wherein vertically aligned cores of the columns are filled with reinforcement.

28. The fence of claim 26, wherein the reinforcement is selected from concrete grout and rebar, steel pipe and post-tension rods.

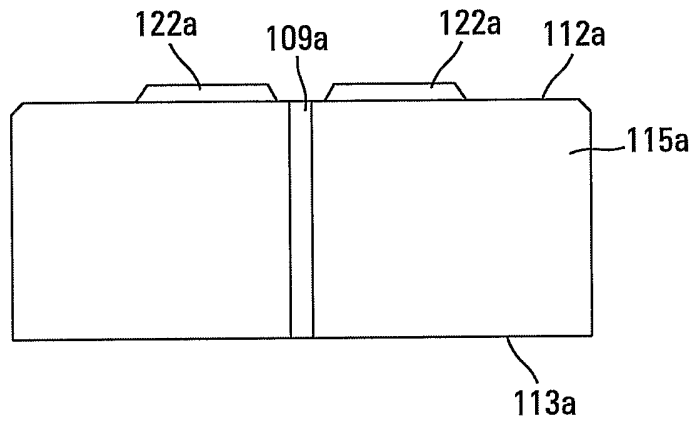
1/24



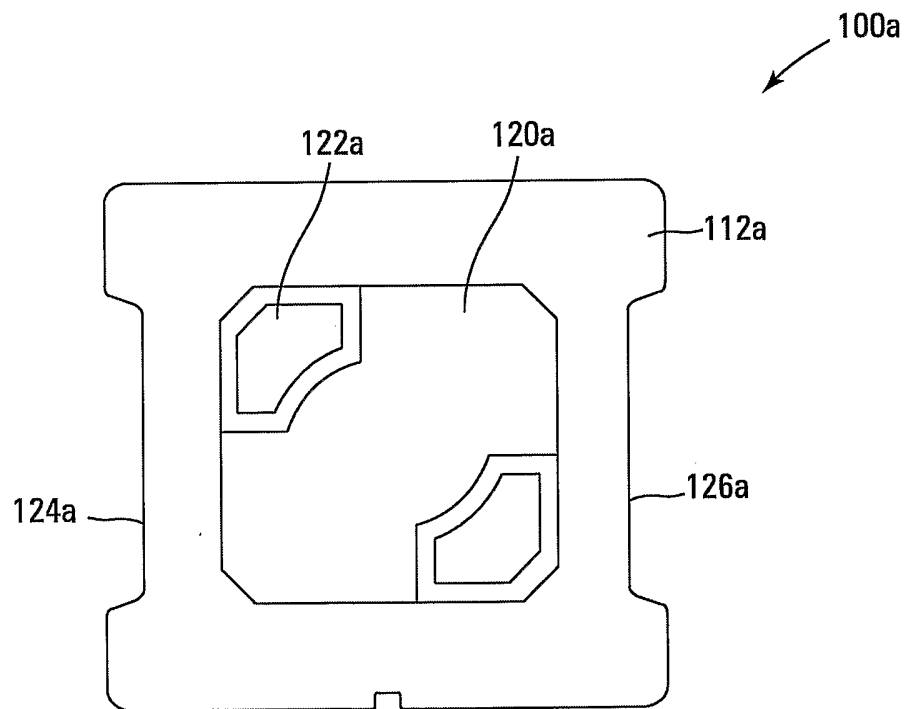
*Fig. 1*



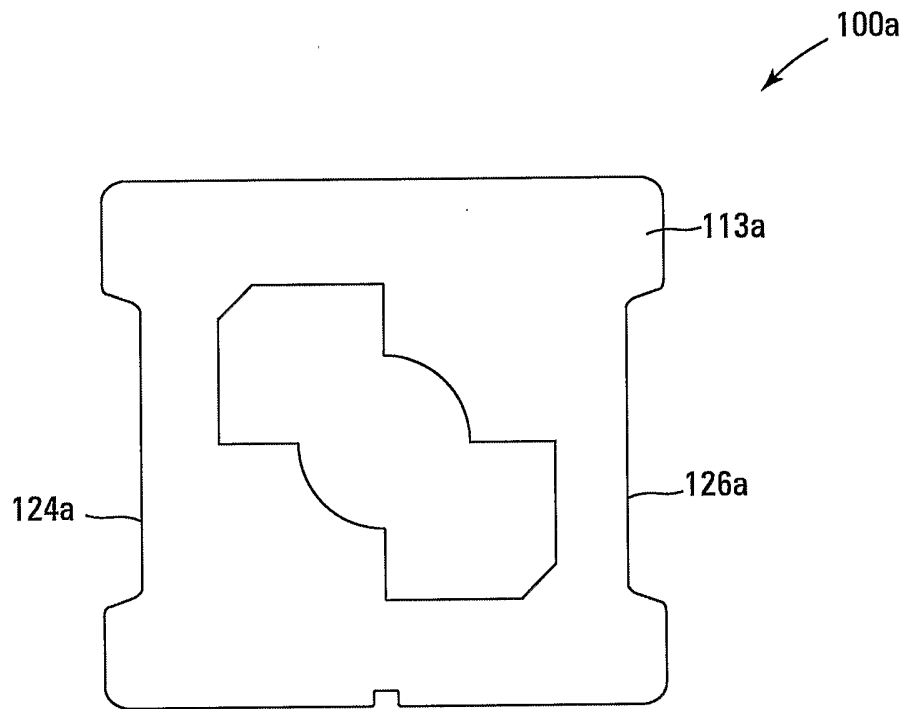
2/24



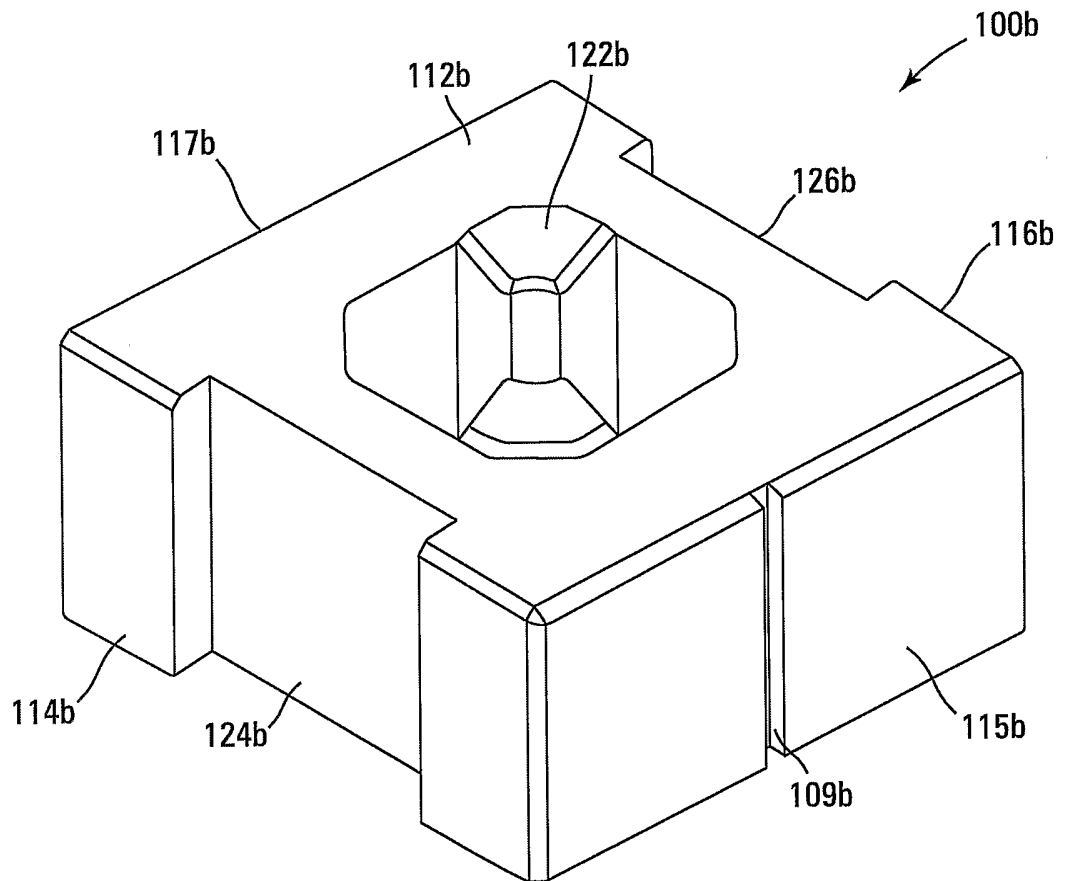
*Fig. 2A*



*Fig. 2B*

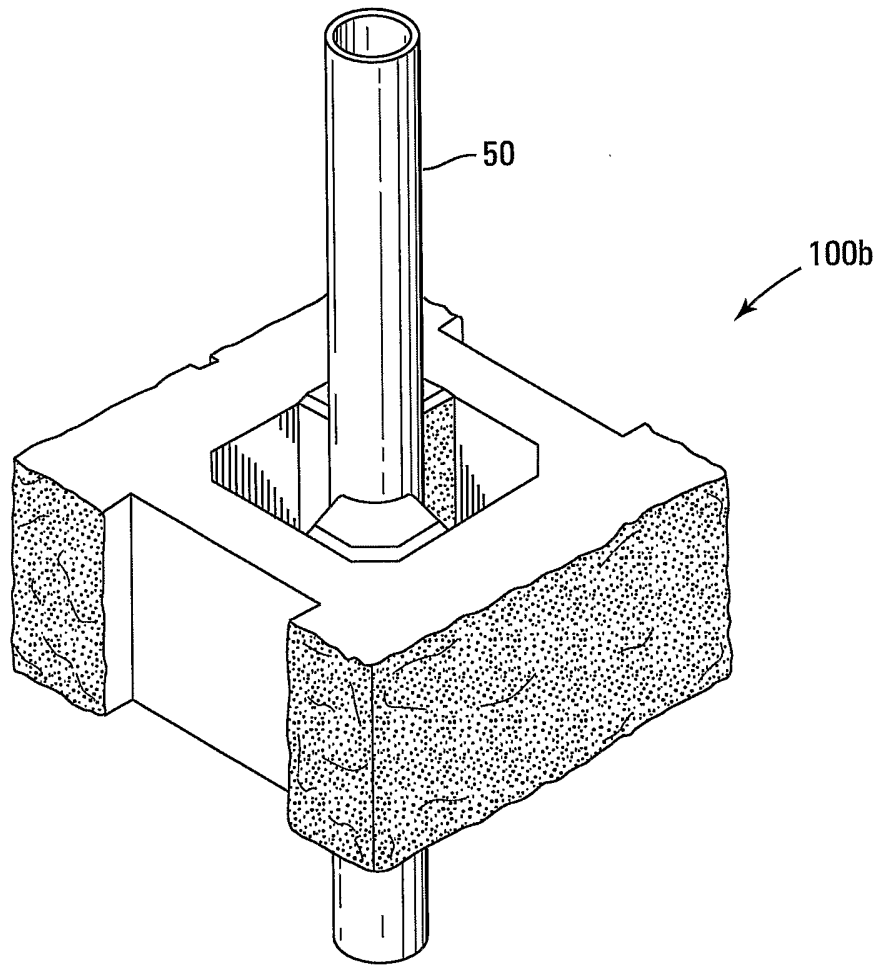


*Fig. 2C*

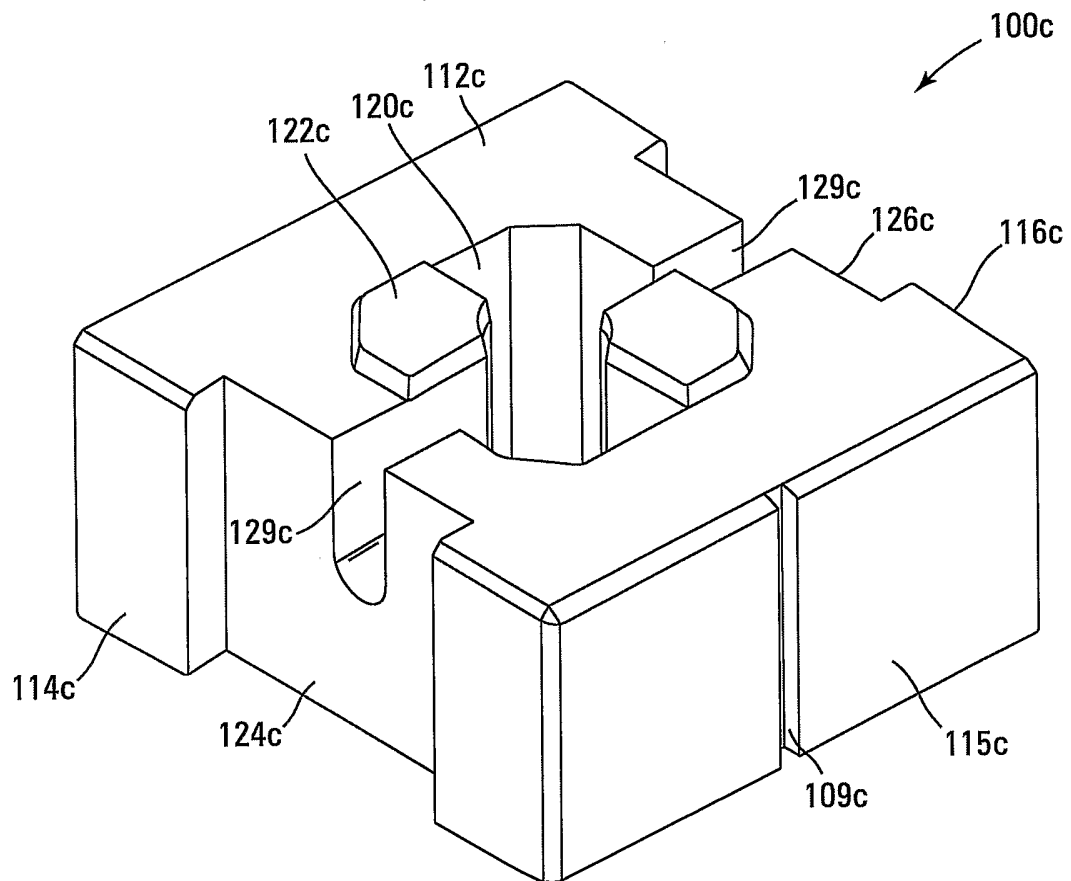


*Fig. 3*

5/24

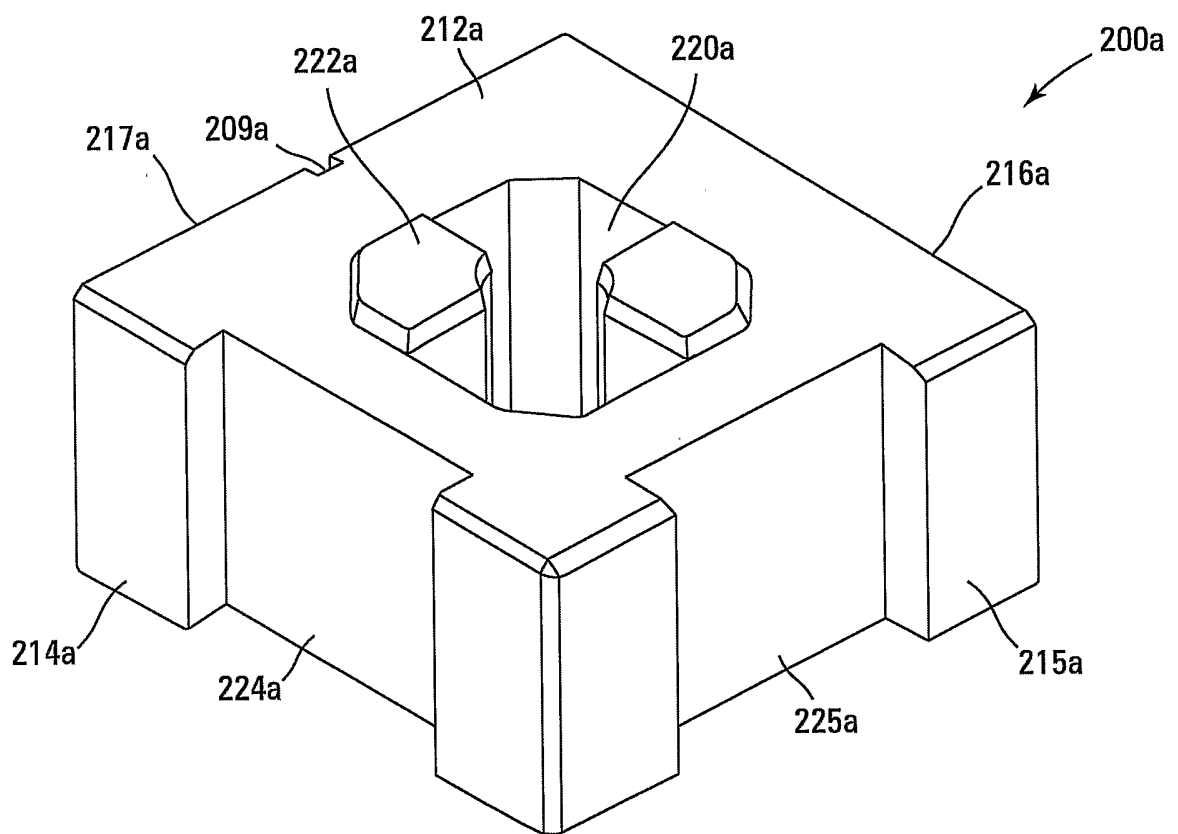


*Fig. 4*



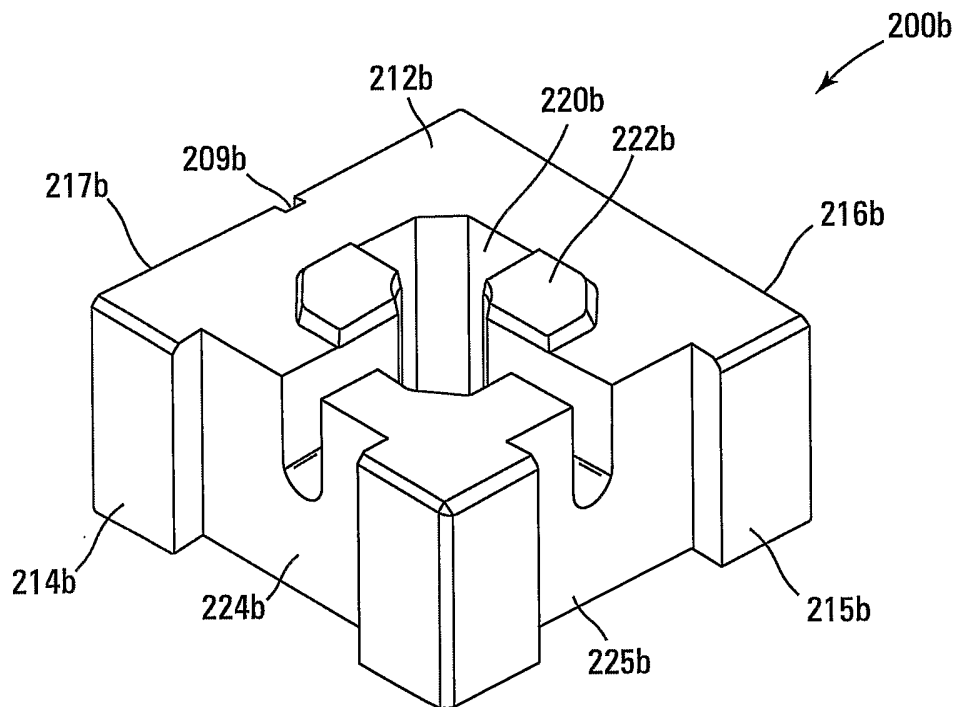
*Fig. 5*

7/24

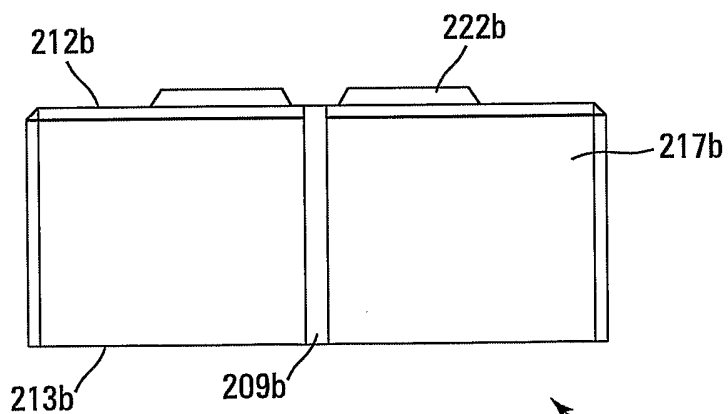


*Fig. 6*

8/24

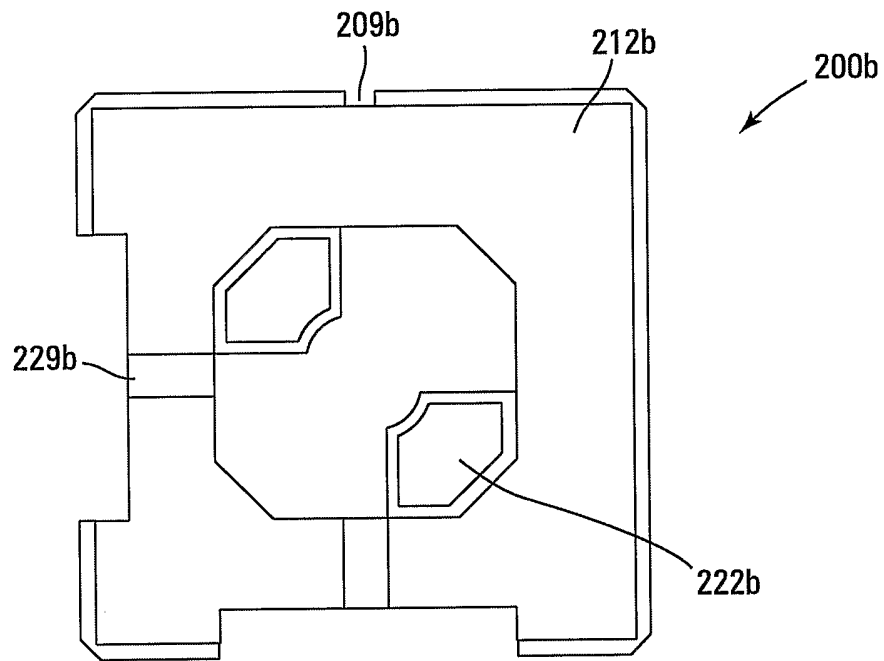


*Fig. 7*

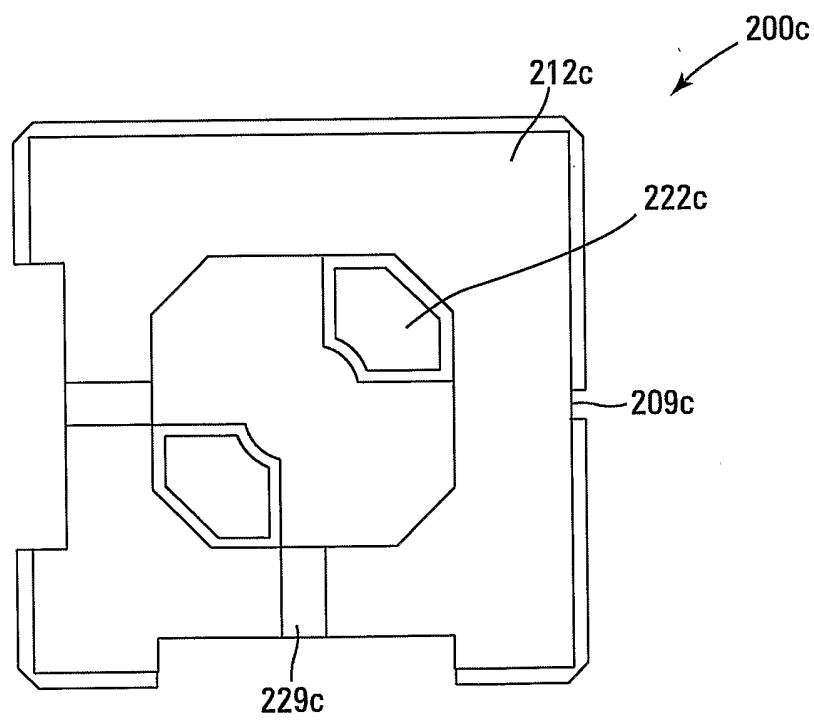


*Fig. 8*

9/24



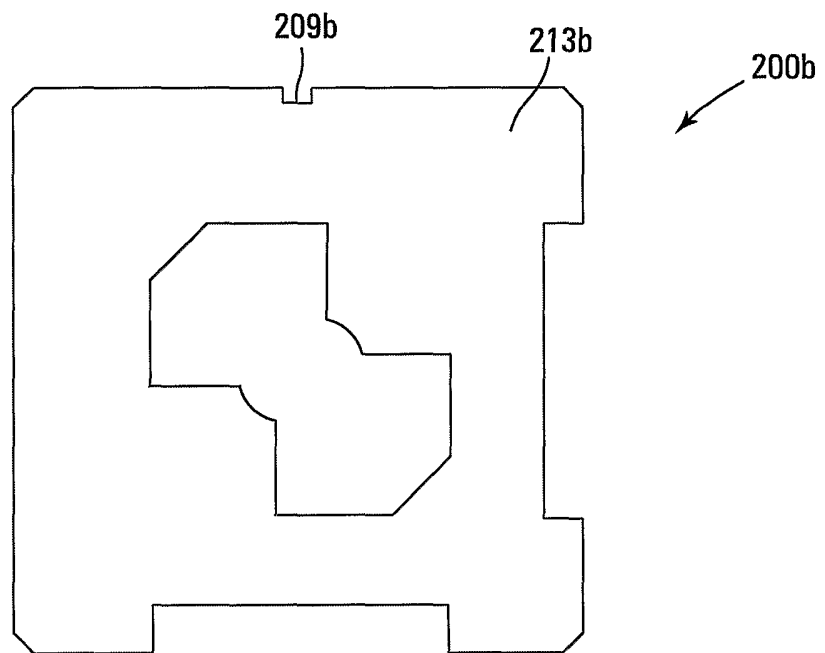
*Fig. 9A*



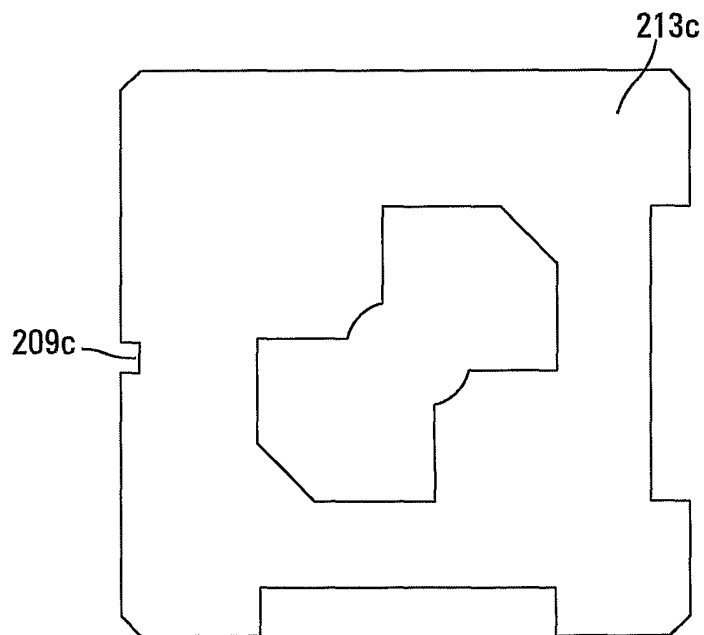
*Fig. 9B*



10/24

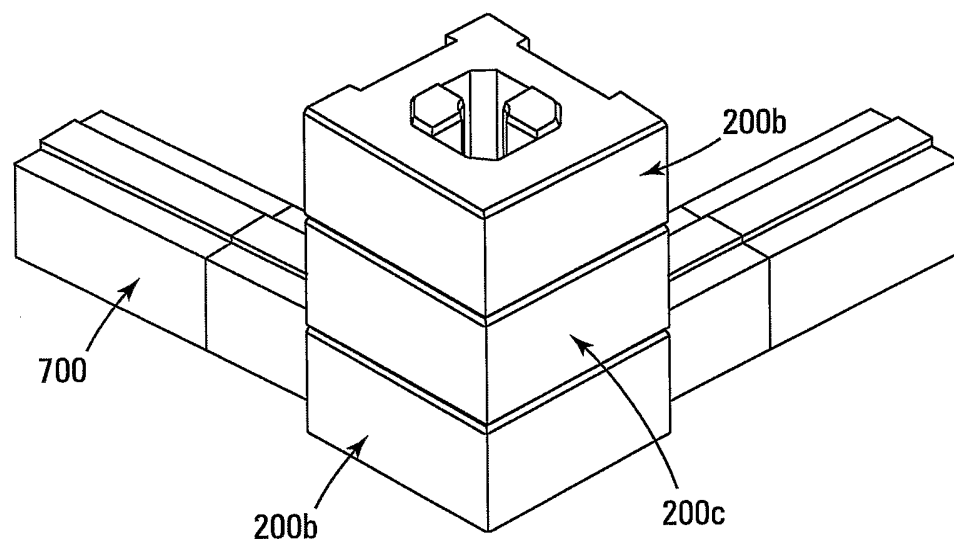


*Fig. 10A*

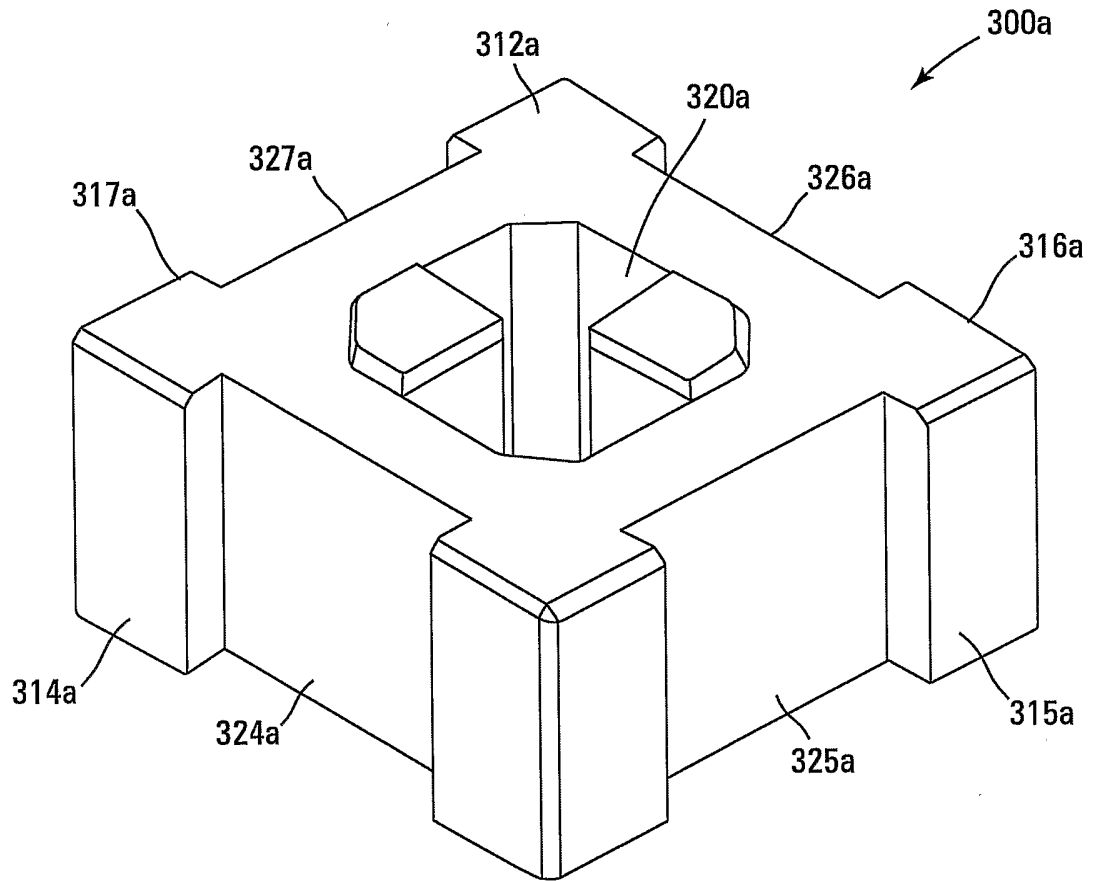


*Fig. 10B*

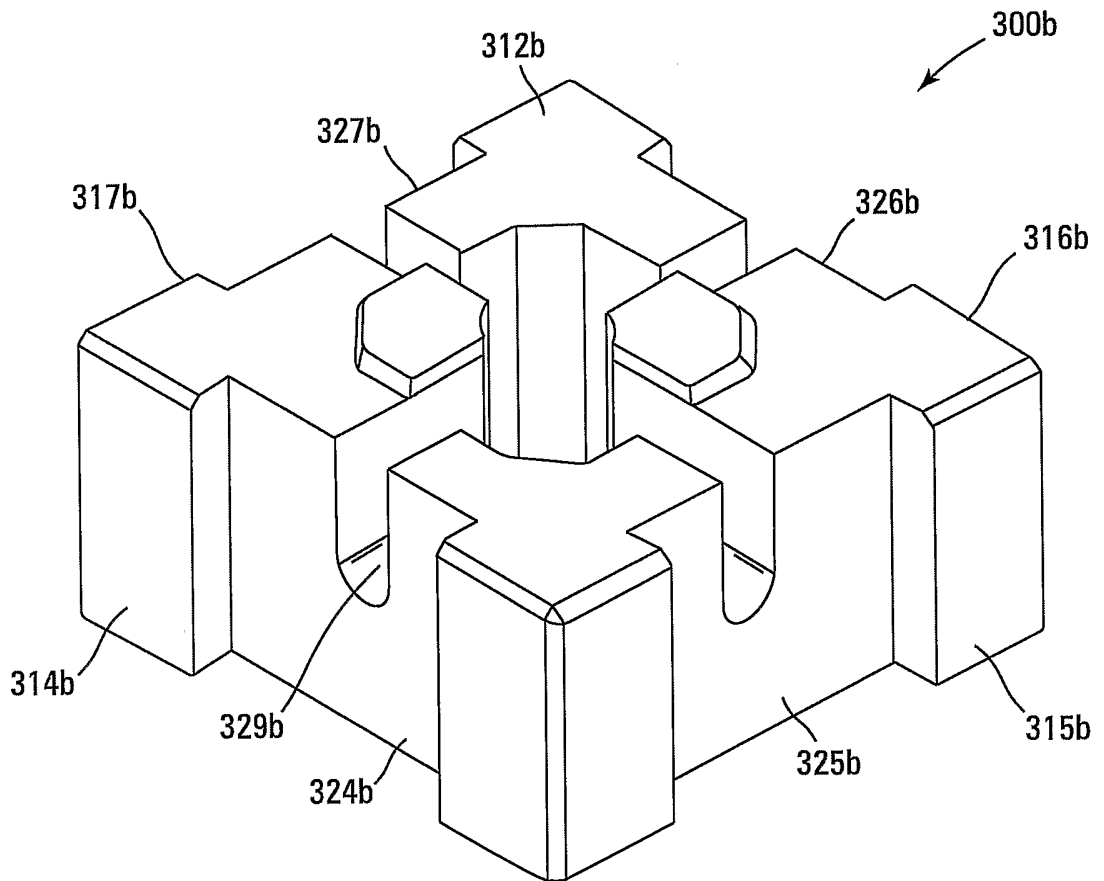
11/24



*Fig. 11*

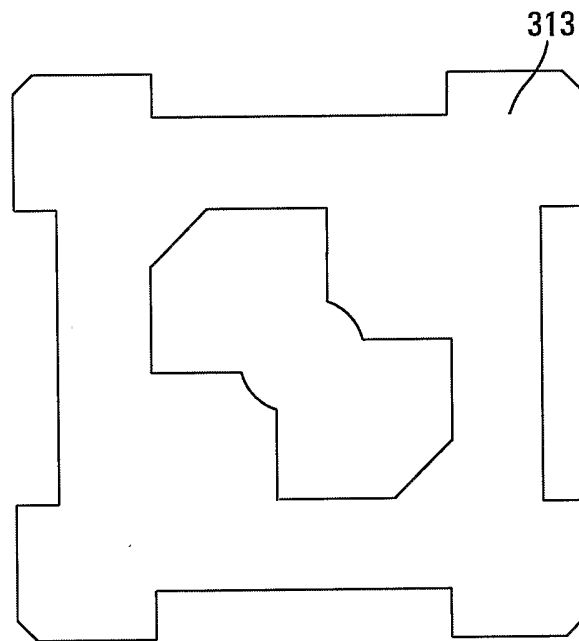


*Fig. 12*

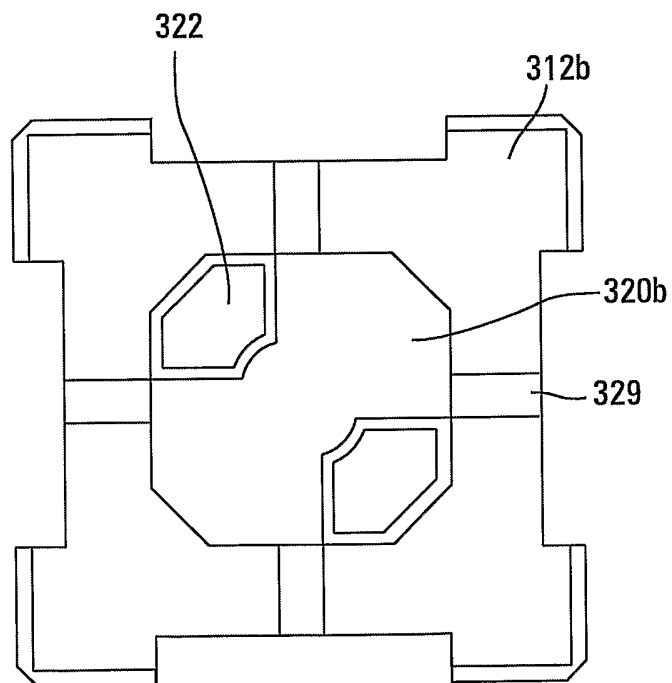


*Fig. 13*

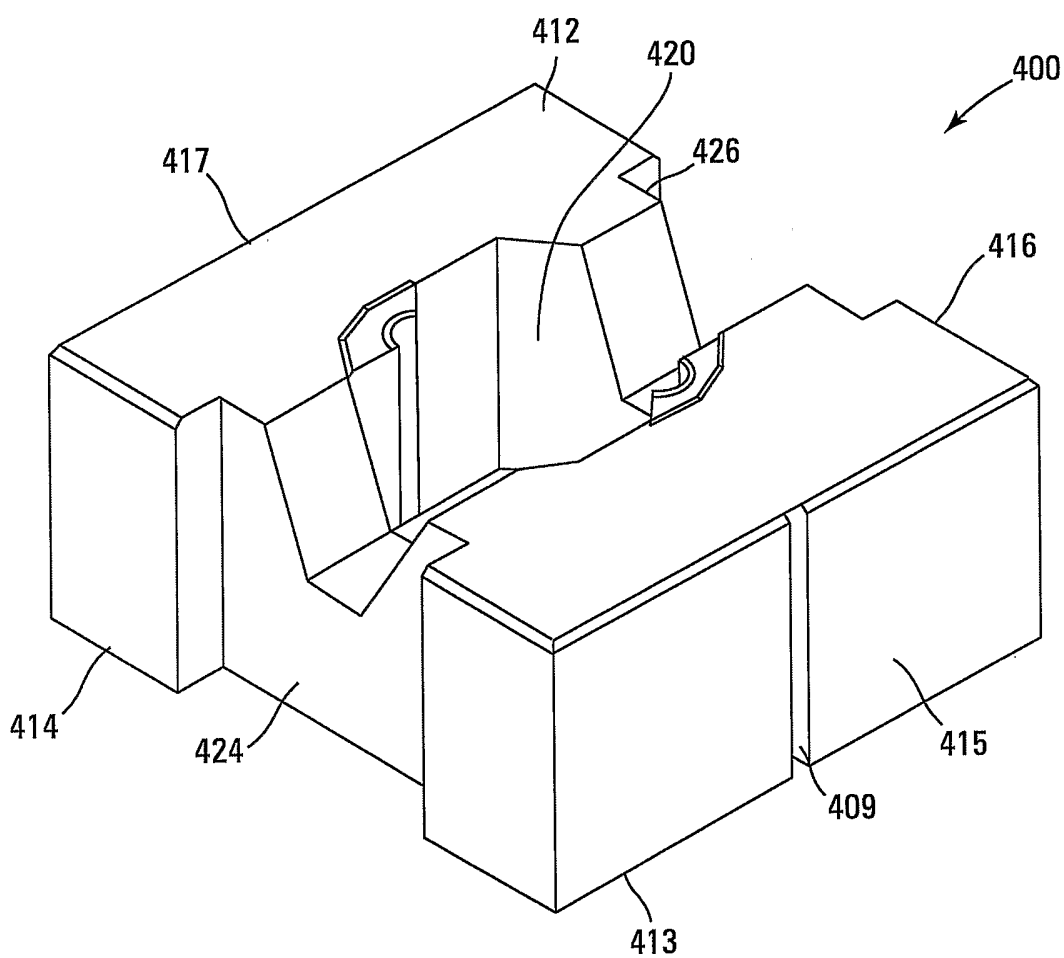
14/24



*Fig. 14A*

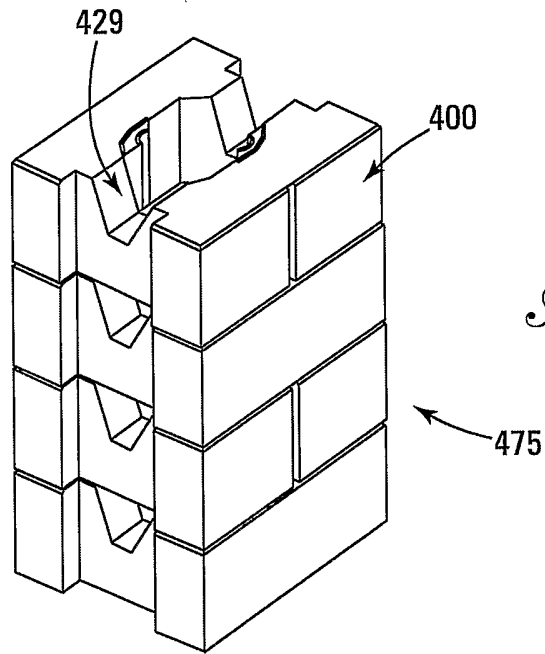


*Fig. 14B*

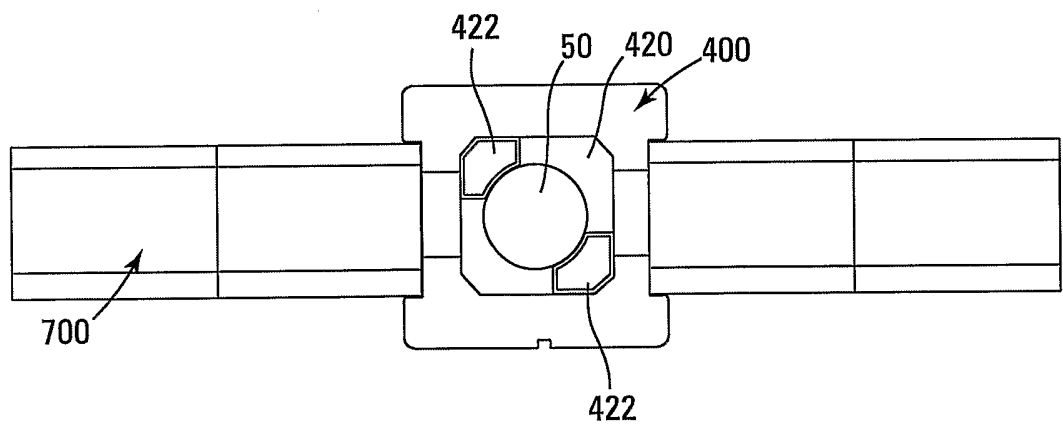


*Fig. 15*

16/24

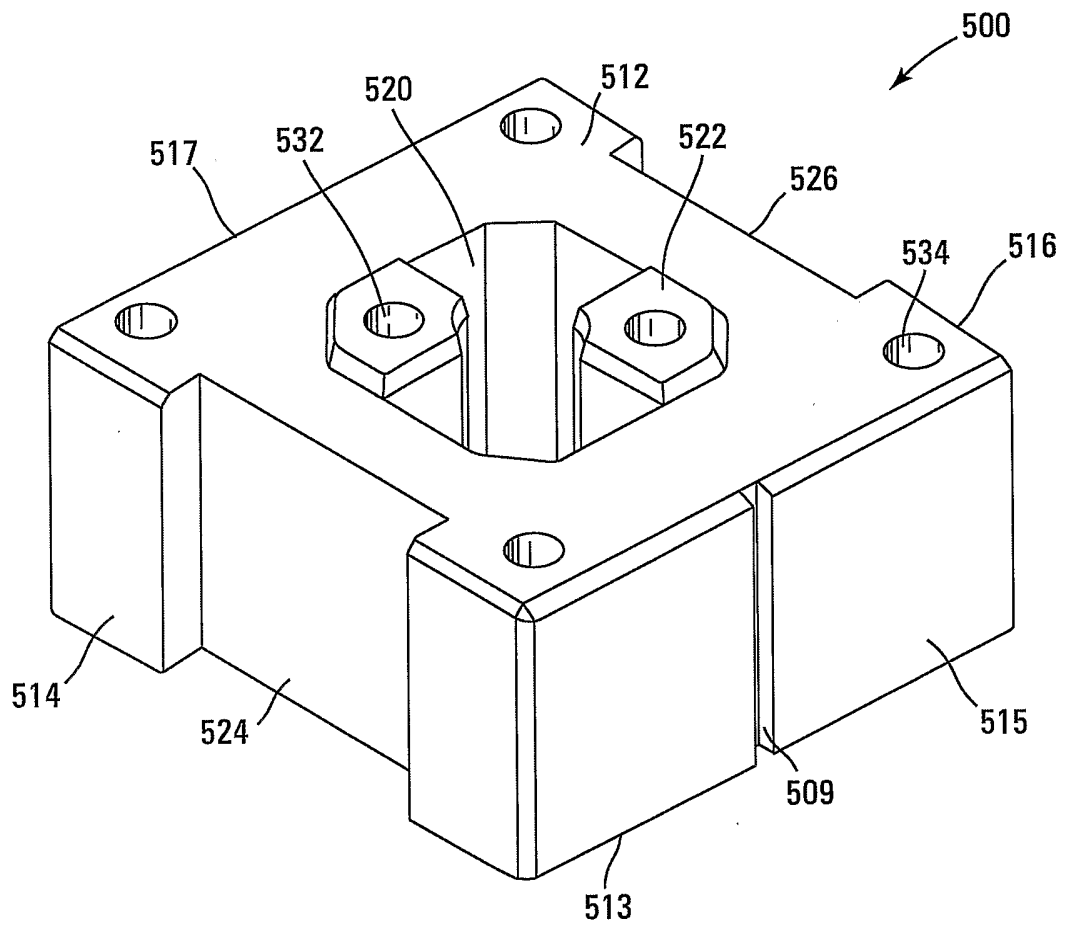


*Fig. 16*



*Fig. 17*

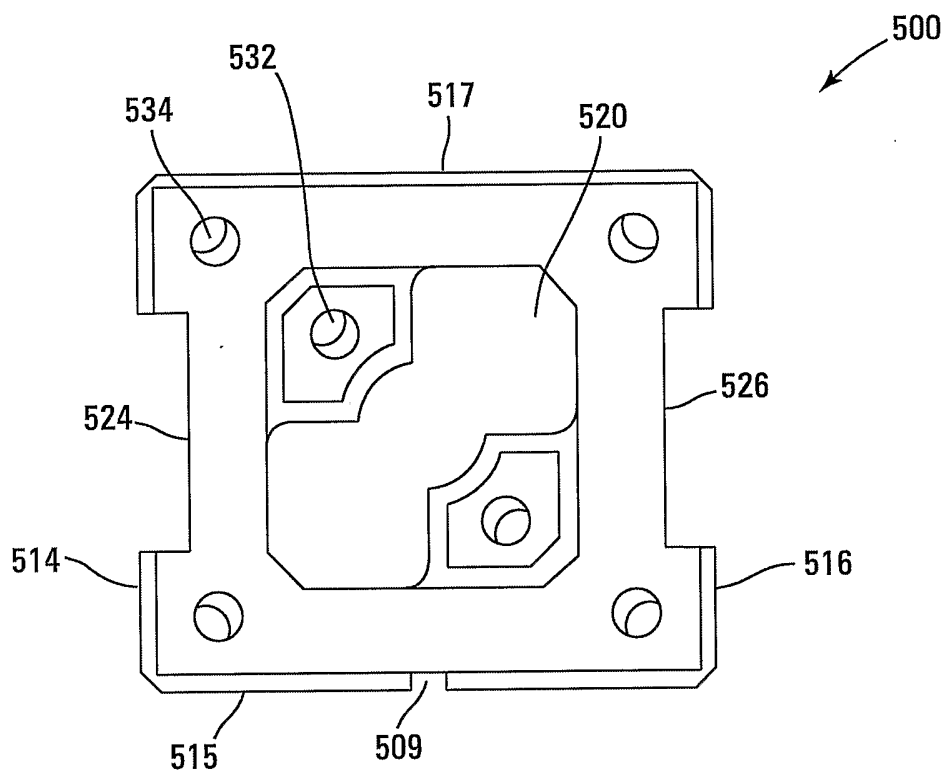
17/24



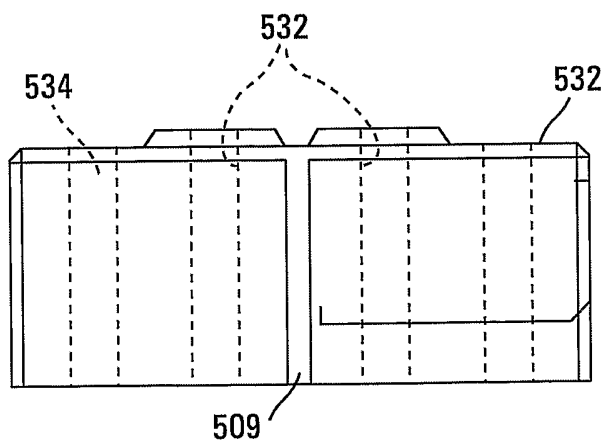
*Fig. 18*



18/24

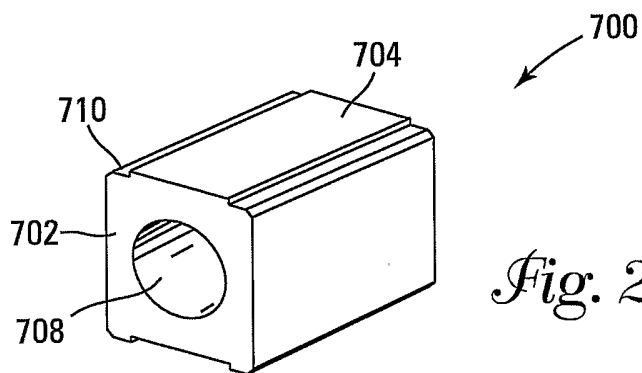


*Fig. 19A*

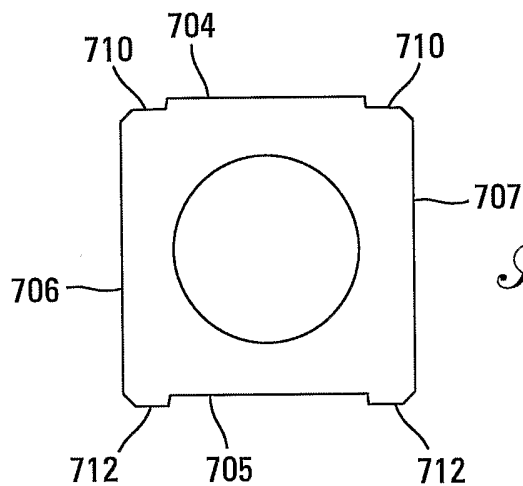


*Fig. 19B*

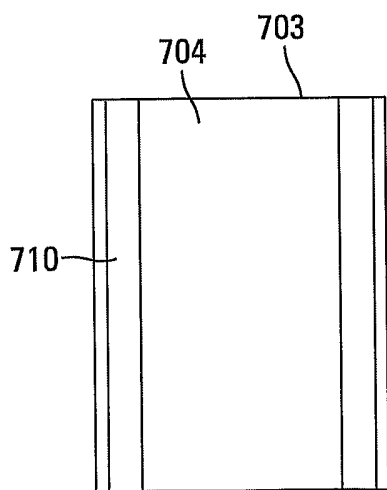
19/24



*Fig. 20A*

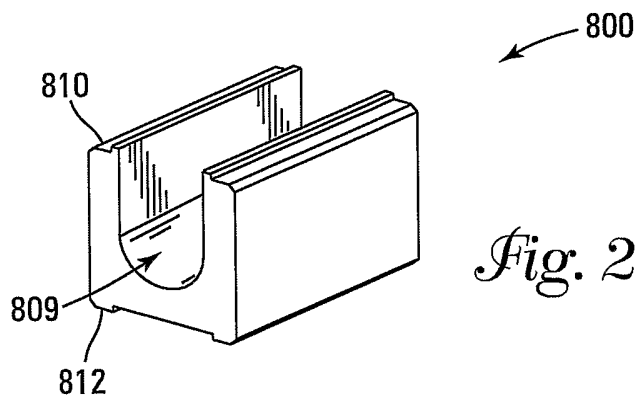


*Fig. 20B*

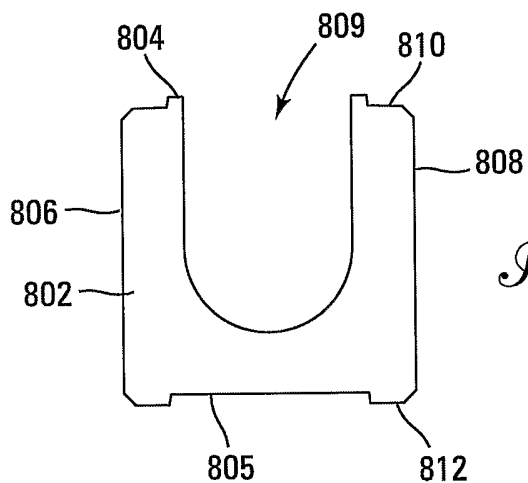


*Fig. 20C*

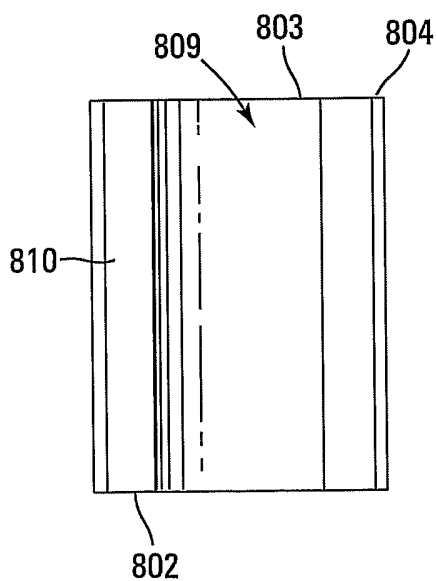
20/24



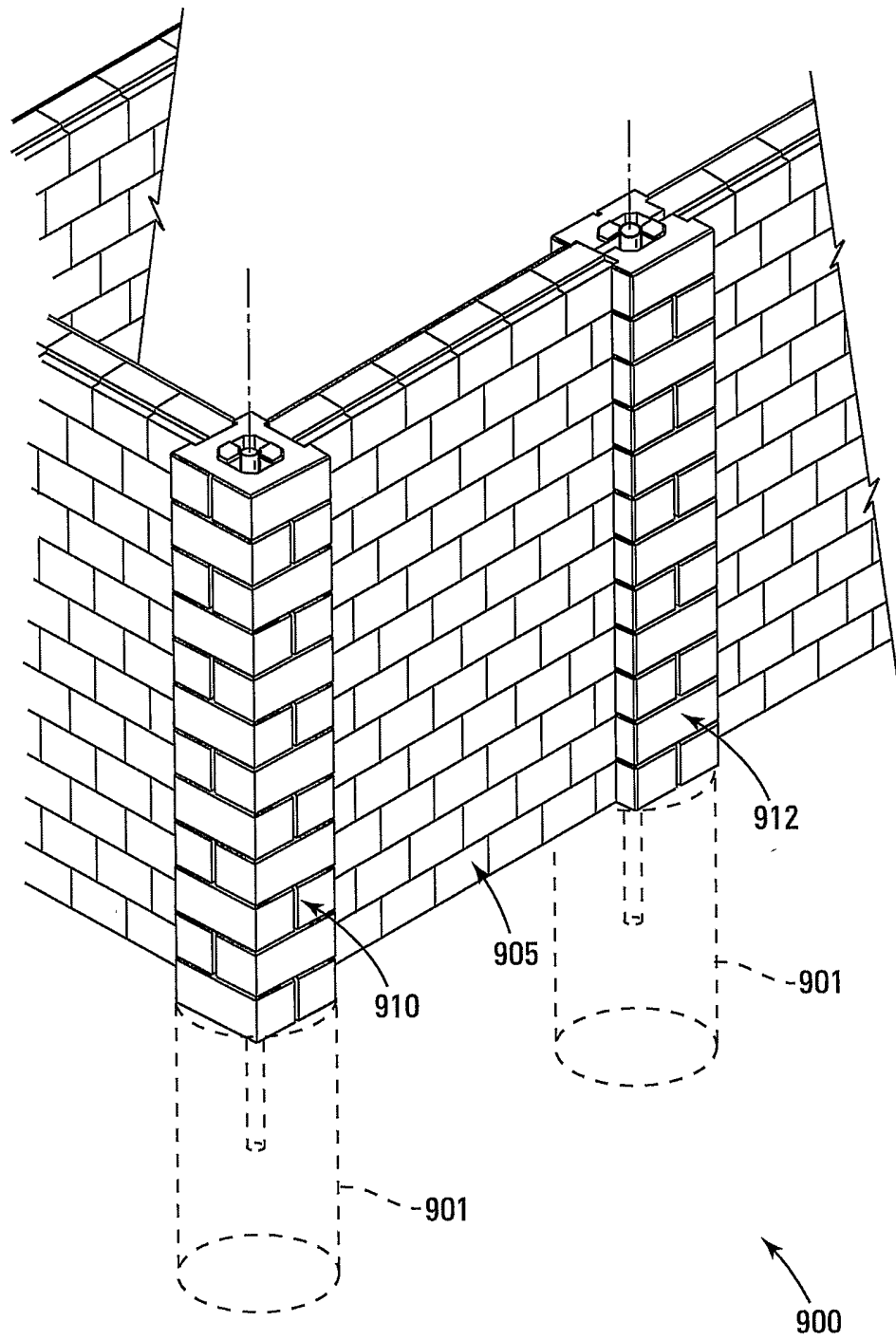
*Fig. 21A*



*Fig. 21B*

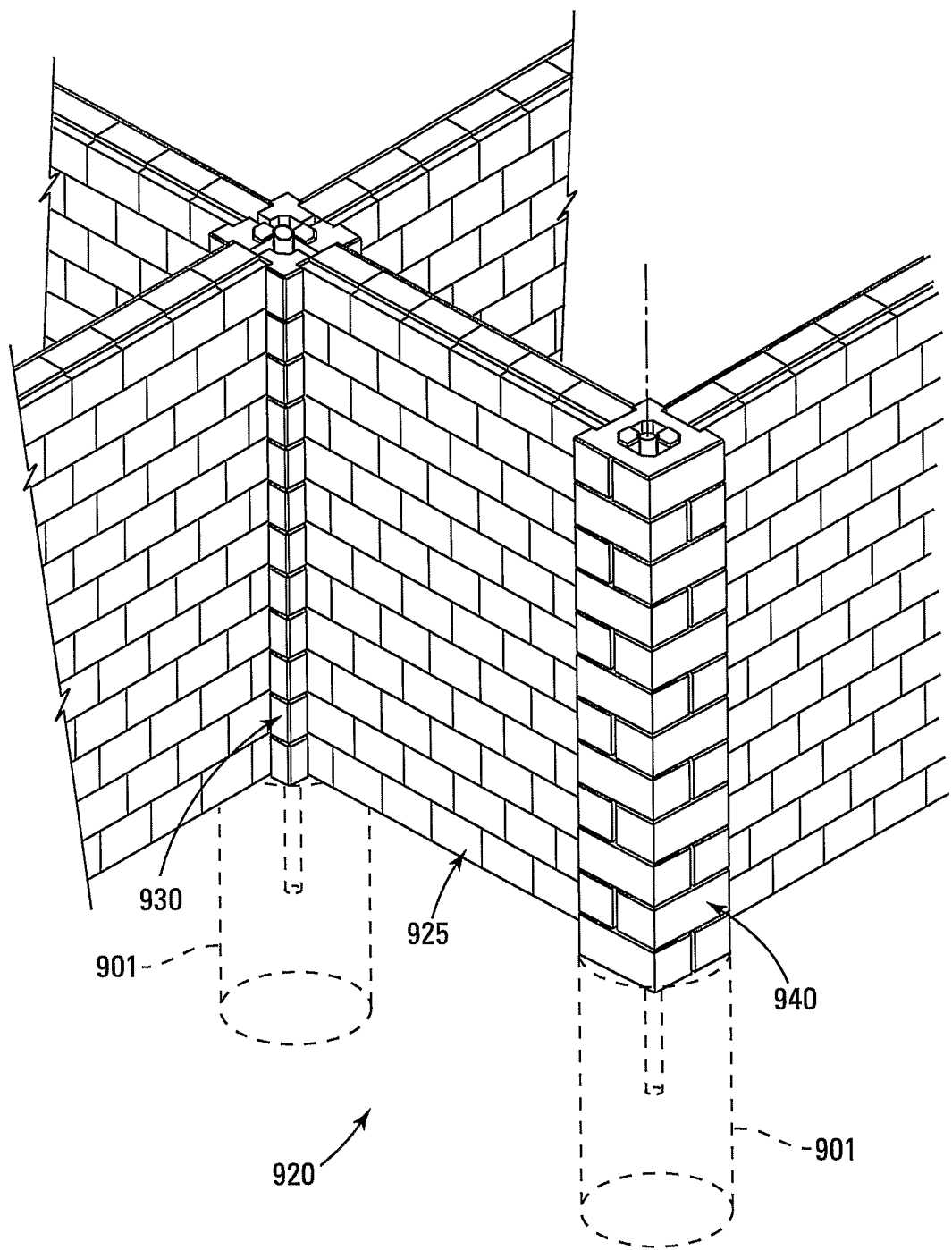


*Fig. 21C*



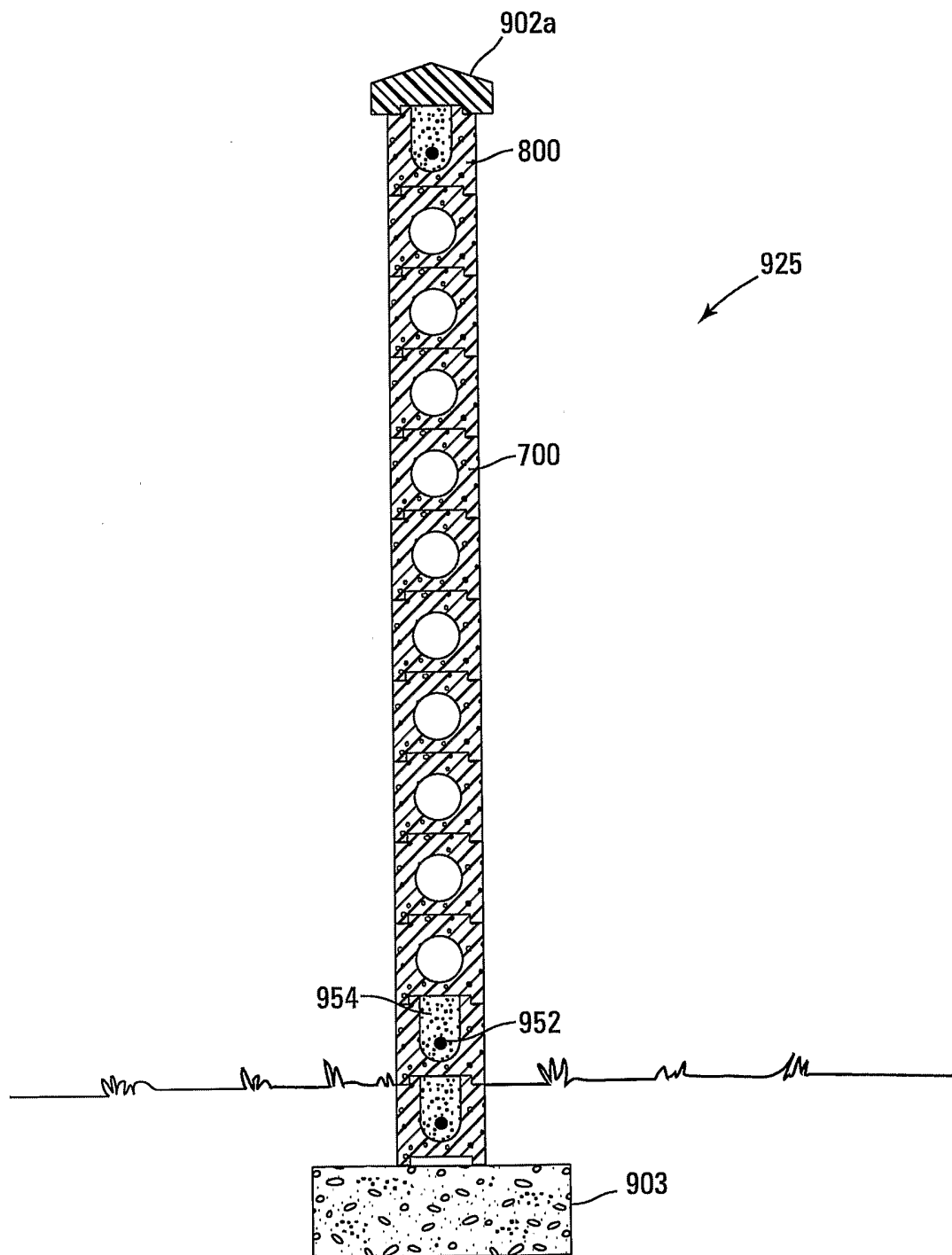
*Fig. 22*

22/24

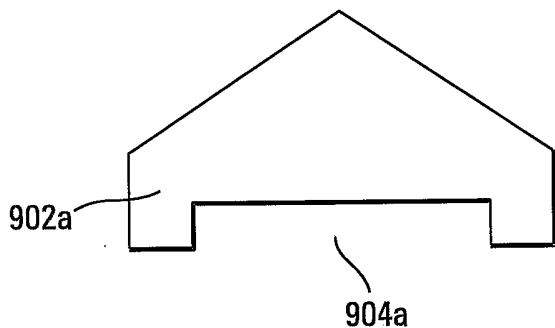


*Fig. 23*

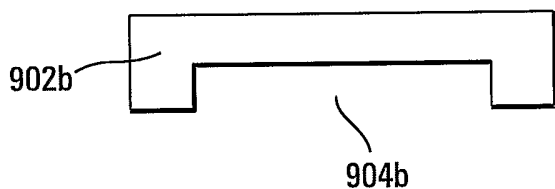
23/24



*Fig. 24*



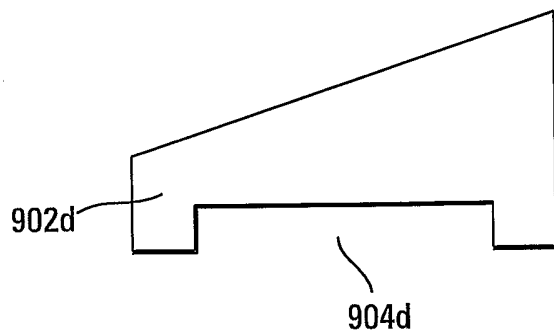
*Fig. 25A*



*Fig. 25B*



*Fig. 25C*



*Fig. 25D*

**INTERNATIONAL SEARCH REPORT**

International Application No  
PCT/US2005/014676

**A. CLASSIFICATION OF SUBJECT MATTER**

IPC 7 E04C1/39 E04H17/14

According to International Patent Classification (IPC) or to both national classification and IPC

**B. FIELDS SEARCHED**

Minimum documentation searched (classification system followed by classification symbols)

IPC 7 E04C E04H E01F E04B

Documentation searched other than minimum documentation to the extent that such documents are included in the fields searched

Electronic data base consulted during the international search (name of data base and, where practical, search terms used)

EPO-Internal

**C. DOCUMENTS CONSIDERED TO BE RELEVANT**

Category °	Citation of document, with indication, where appropriate, of the relevant passages	Relevant to claim No.
X	US 5 623 797 A (GRAVIER ET AL.) 29 April 1997 (1997-04-29)	1-4, 8, 9, 12-14, 18-28
Y	column 3, line 61 - column 6, line 63 column 8, line 24 - line 39; figures 1-6, 10, 11	5, 15
Y	US 2003/089068 A1 (AMEIGH) 15 May 2003 (2003-05-15) paragraph '0024!; figure 2	5, 15
X	US 4 107 894 A (MULLINS) 22 August 1978 (1978-08-22) column 4, line 50 - column 6, line 41; figures 1-7, 10	12, 13, 16-18, 21
X	WO 99/05370 A (KOBAKHIDZE) 4 February 1999 (1999-02-04) figures 10, 11, 25	12, 16, 18-21

Further documents are listed in the continuation of box C.

Patent family members are listed in annex.

° Special categories of cited documents :

- \*A\* document defining the general state of the art which is not considered to be of particular relevance
- \*E\* earlier document but published on or after the international filing date
- \*L\* document which may throw doubts on priority claim(s) or which is cited to establish the publication date of another citation or other special reason (as specified)
- \*O\* document referring to an oral disclosure, use, exhibition or other means
- \*P\* document published prior to the international filing date but later than the priority date claimed

- \*T\* later document published after the international filing date or priority date and not in conflict with the application but cited to understand the principle or theory underlying the invention
- \*X\* document of particular relevance; the claimed invention cannot be considered novel or cannot be considered to involve an inventive step when the document is taken alone
- \*Y\* document of particular relevance; the claimed invention cannot be considered to involve an inventive step when the document is combined with one or more other such documents, such combination being obvious to a person skilled in the art.
- \*&\* document member of the same patent family

Date of the actual completion of the international search

30 August 2005

Date of mailing of the international search report

06/09/2005

Name and mailing address of the ISA

European Patent Office, P.B. 5818 Patentlaan 2  
NL - 2280 HV Rijswijk  
Tel. (+31-70) 340-2040, Tx. 31 651 epo nl,  
Fax: (+31-70) 340-3016

Authorized officer

Mysliwetz, W



# INTERNATIONAL SEARCH REPORT

Information on patent family members

International Application No  
PCT/US2005/014676

Patent document cited in search report	A	Publication date	Patent family member(s)	Publication date
US 5623797	A	29-04-1997	CA 2182321 A1	31-01-1998
			WO 9821421 A1	22-05-1998
			AU 7675396 A	03-06-1998
			AU 721301 B2	29-06-2000
			DE 948684 T1	17-02-2000
			EP 0948684 A1	13-10-1999
<hr/>				
US 2003089068	A1	15-05-2003	NONE	
<hr/>				
US 4107894	A	22-08-1978	NONE	
<hr/>				
WO 9905370	A	04-02-1999	WO 9905370 A1	04-02-1999
			AU 3554897 A	16-02-1999
<hr/>				