

(21) Application No: **0322777.4**

(22) Date of Filing: **29.09.2003**

(71) Applicant(s):
Nokia Corporation
(Incorporated in Finland)
Keilalahdentie 4, FIN-02150 Espoo, Finland

(72) Inventor(s):
Jussi Vesma
Harri Pekonen

(74) Agent and/or Address for Service:
Venner Shipley LLP
20 Little Britain, LONDON, EC1A 7DH,
United Kingdom

(51) INT CL⁷:
H04N 7/035 , H03M 13/03 , H04B 1/16 , H04H 1/00 ,
H04N 7/64

(52) UK CL (Edition X):
H4P PPEC

(56) Documents Cited:
EP 1306997 A1 **EP 1071221 A1**
WO 2000/070457 A1 **US 20020054608 A1**

(58) Field of Search:
UK CL (Edition V) **H4L, H4P**
INT CL⁷ **H03M, H04B, H04H, H04N**
Other: **Online: WPI, EPODOC, PAJ, INSPEC**

(54) Abstract Title: **Burst transmission**

(57) A method of transmitting bursts in a communications network 1 comprising: providing data for transmission; providing forward error correction (FEC) data for said data; forming a first set of bursts comprising the transmission data; and forming a second set of bursts comprising the FEC data. The first bursts may be transmitted on a different channel to the channel that the second bursts are transmitted on. Timing offset (Δt) information may be provided to indicate the timing between bursts within the first set and second set of bursts. The method may be used to enable power saving at the receiver 2 so that forward error correction data can be selectively received. One specific embodiment comprises: a terrestrial digital video broadcasting (DVB-T) network being used to transmit IP datagrams to receiving devices using multiprotocol encapsulation (MPE). MPE datagram sections and forward error correction datagram sections are transmitted in separate time-sliced bursts using transport stream packets with different packet identifiers (PIDs).

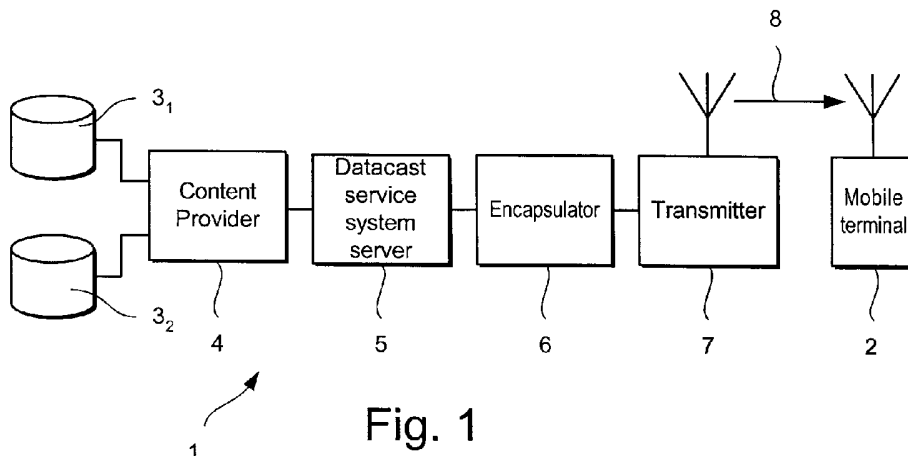

Fig. 1

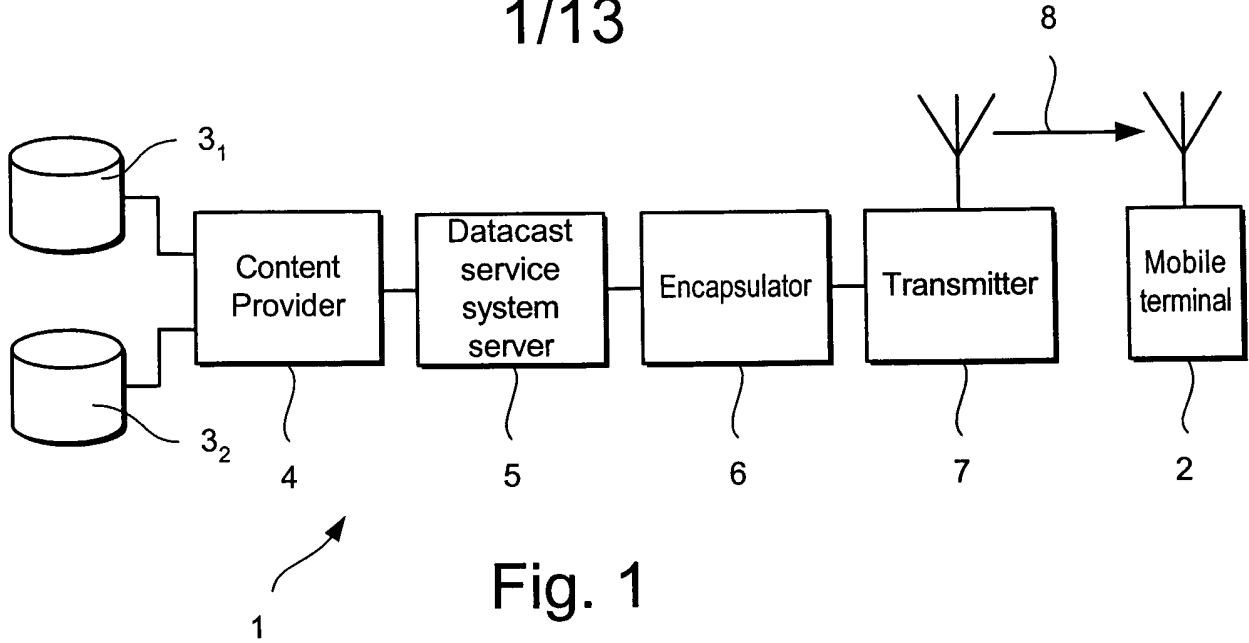

Fig. 1

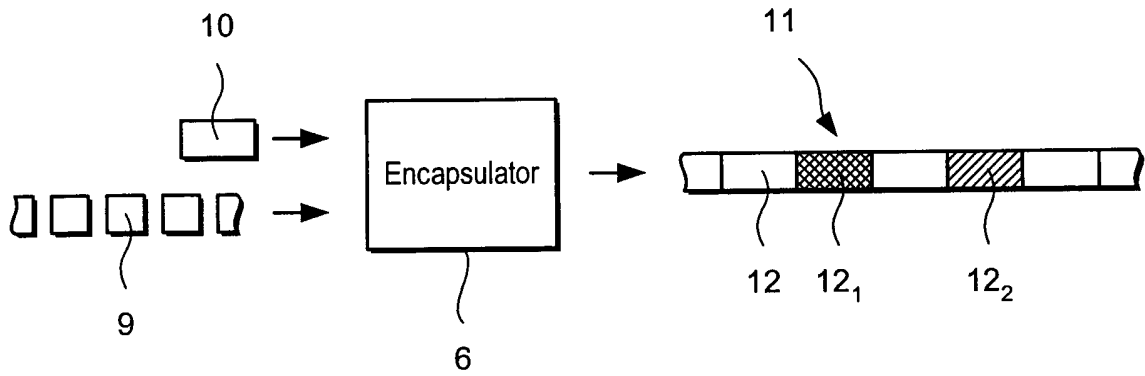

Fig. 2

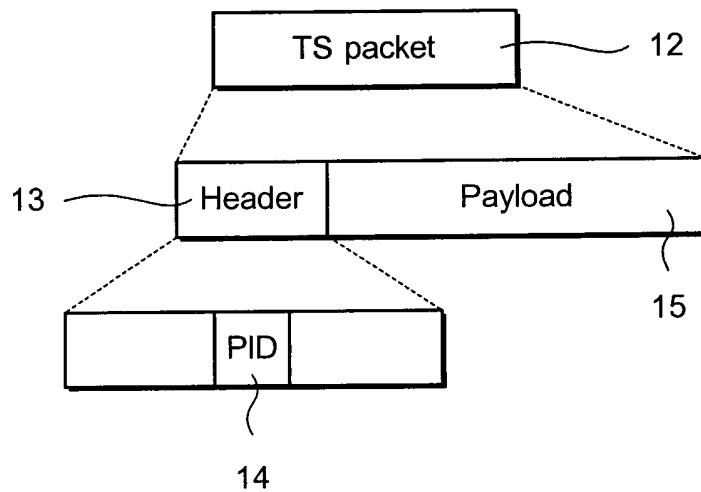

Fig. 3

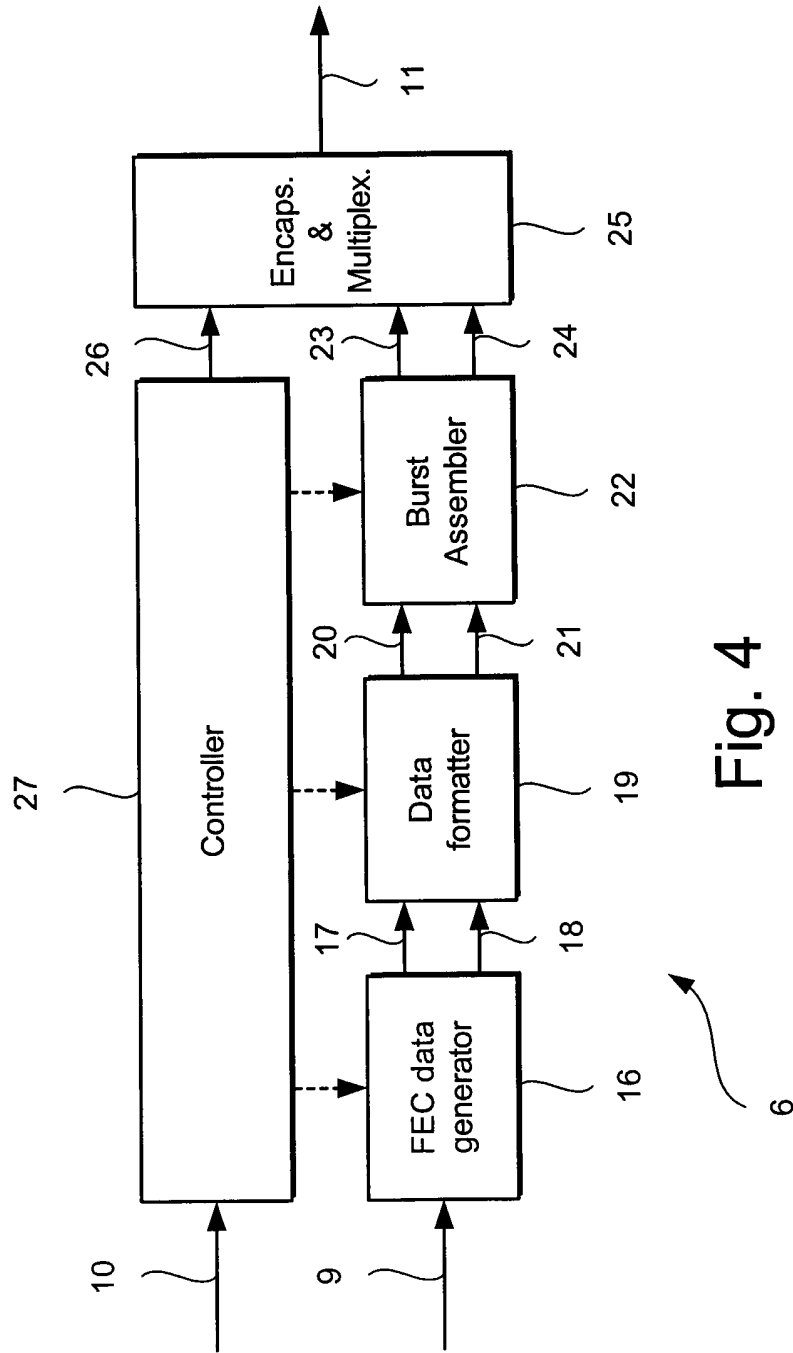

Fig. 4

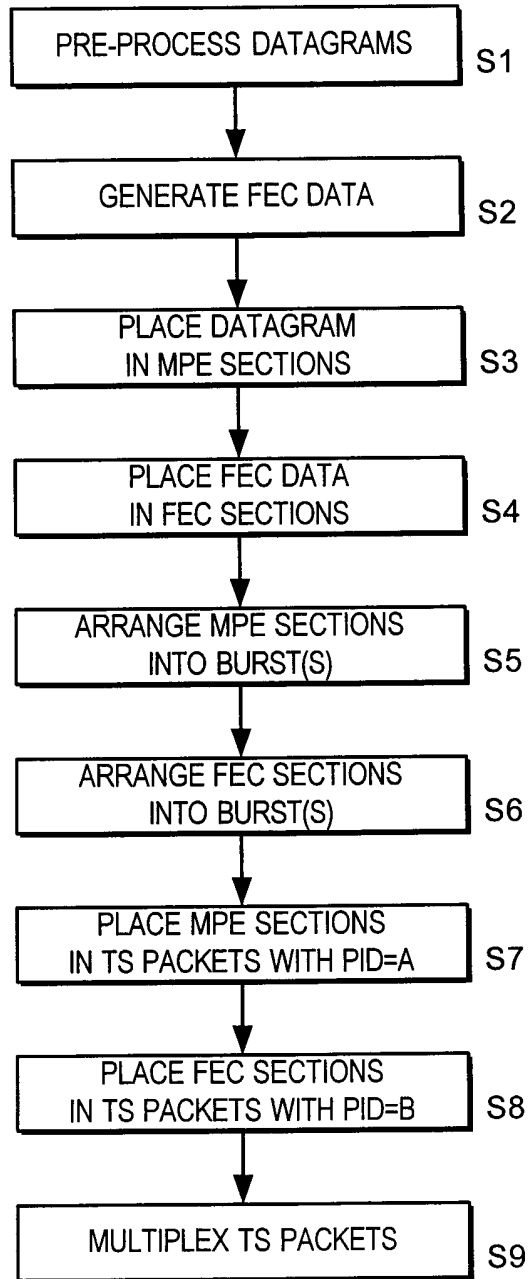

Fig. 5

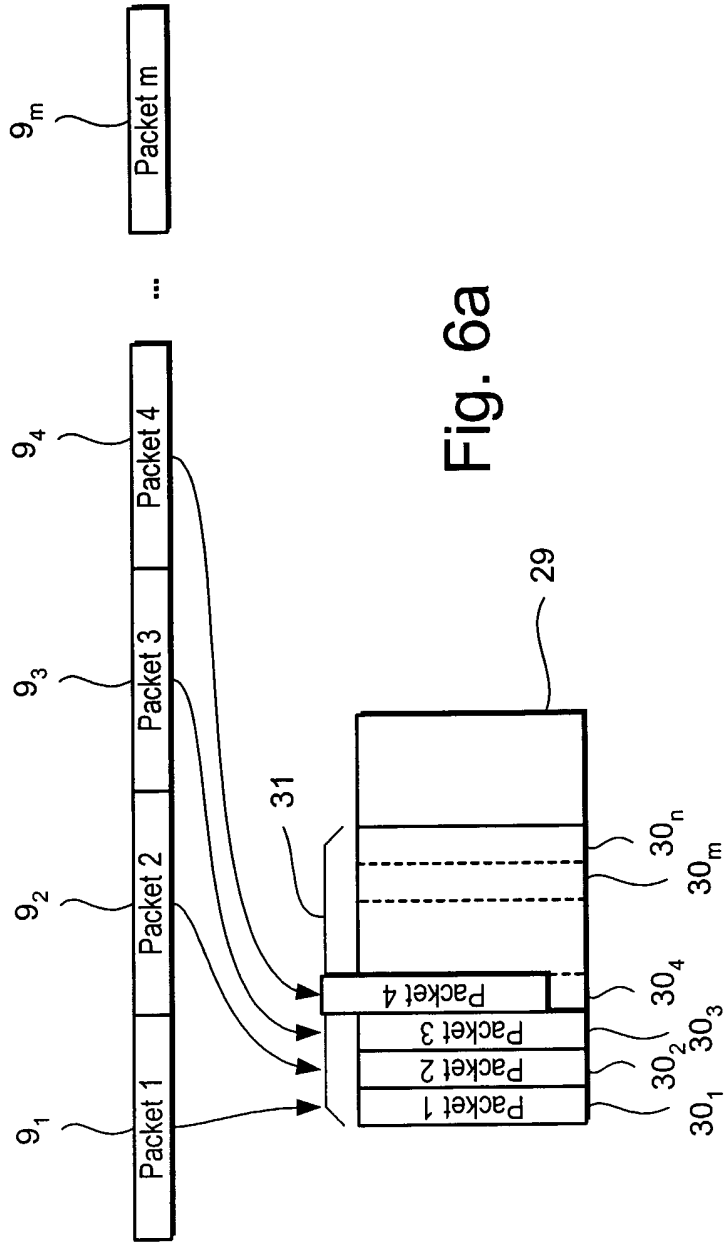

Fig. 6a

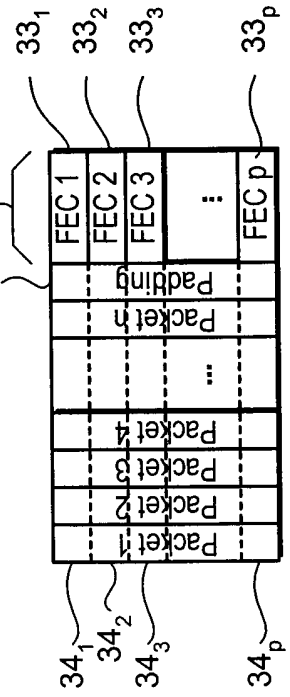
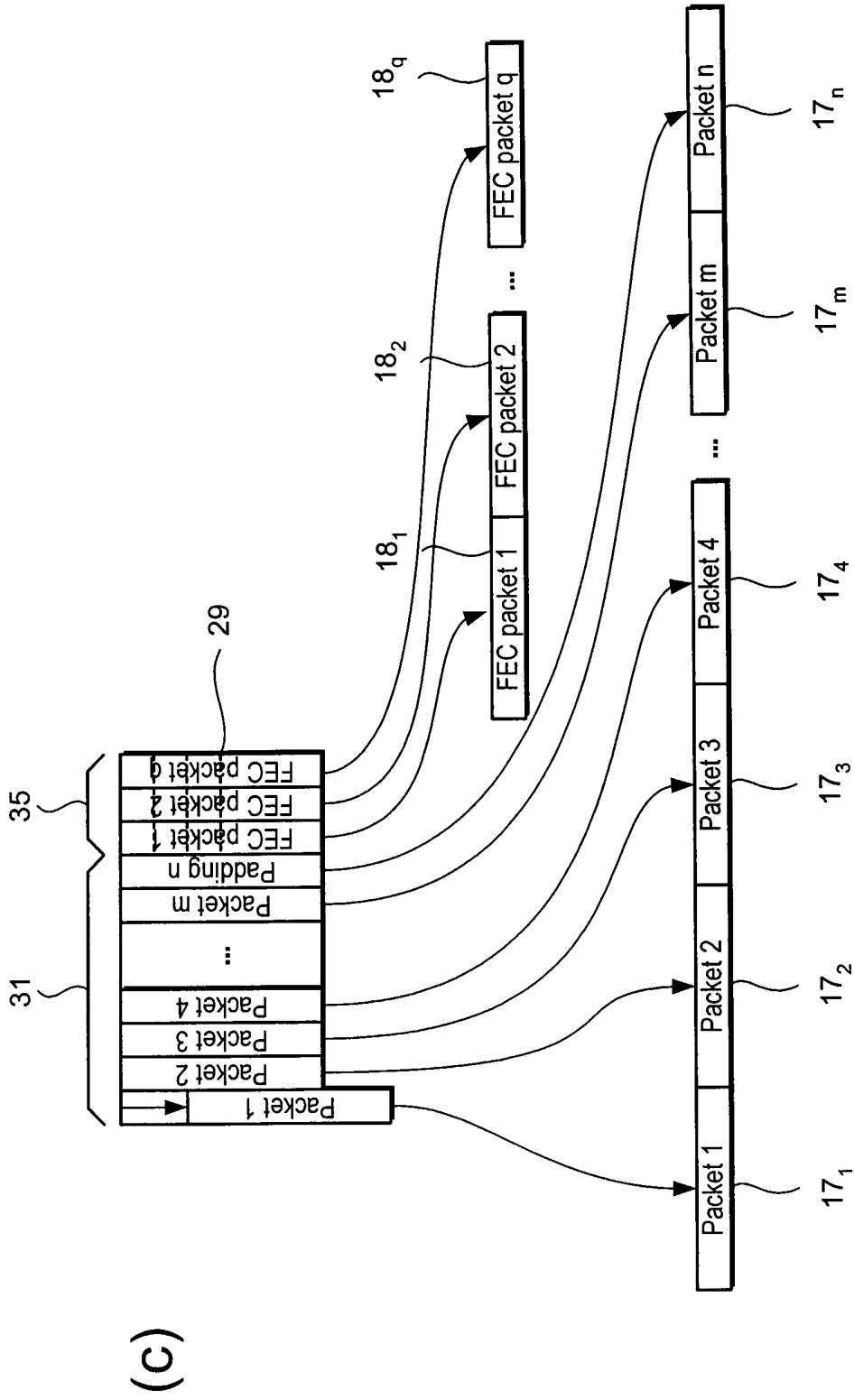

Fig. 6b



(c)

Fig. 6c

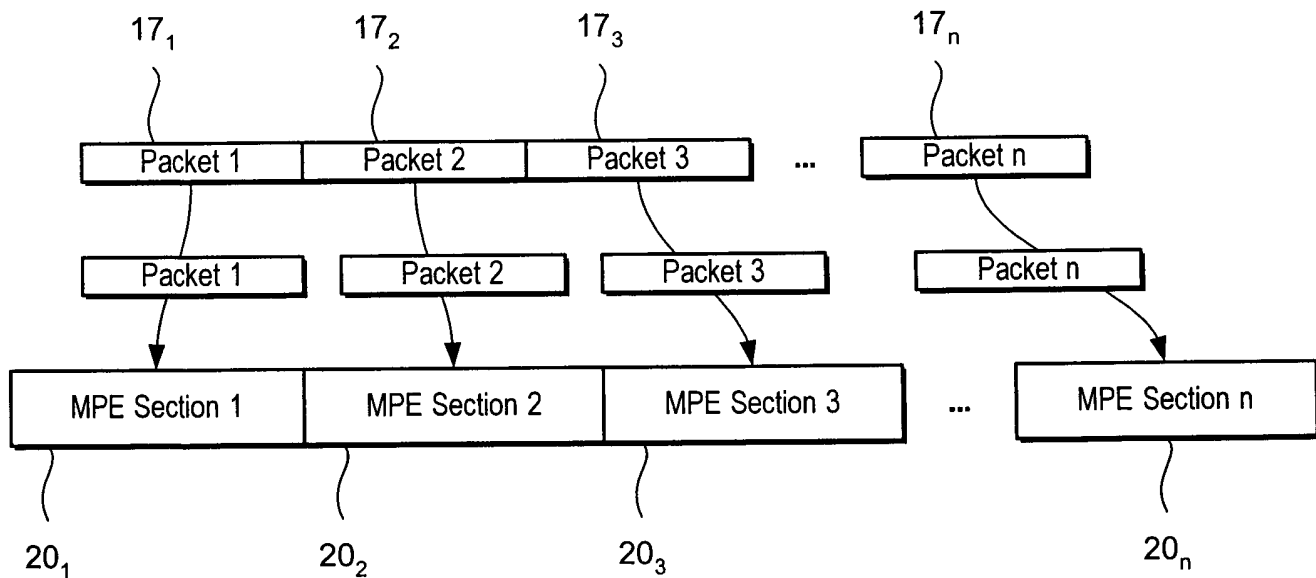

Fig. 7

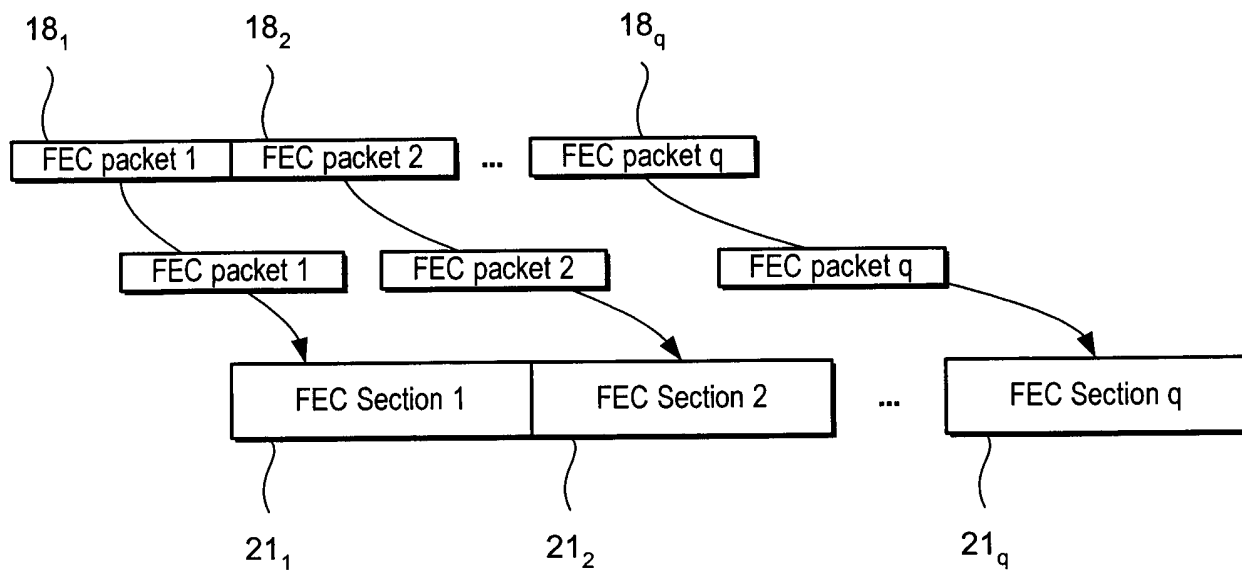

Fig. 8

20, 21

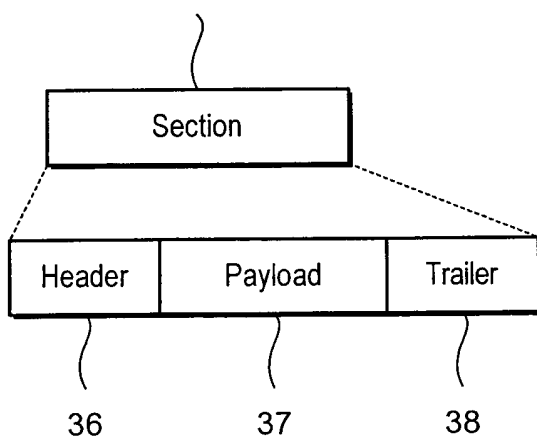

Fig. 9

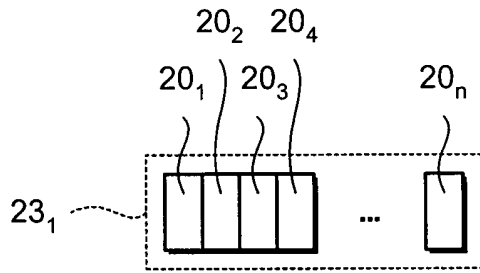

Fig. 10

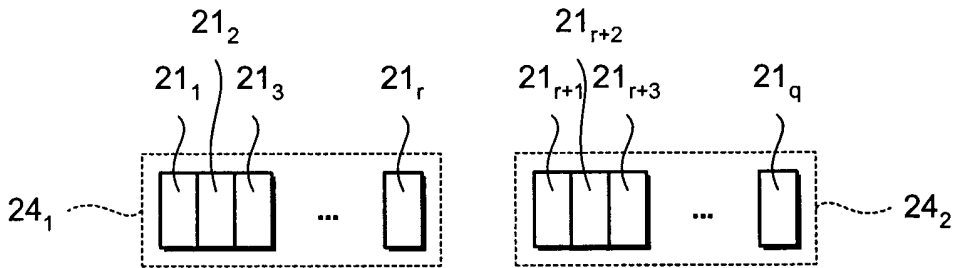

Fig. 11

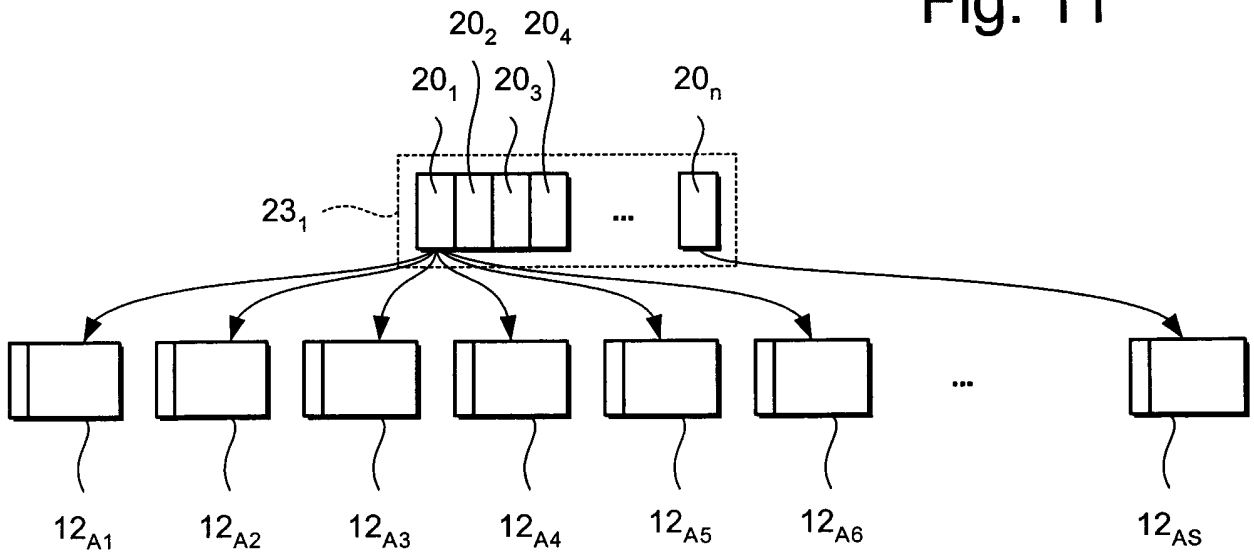

Fig. 13

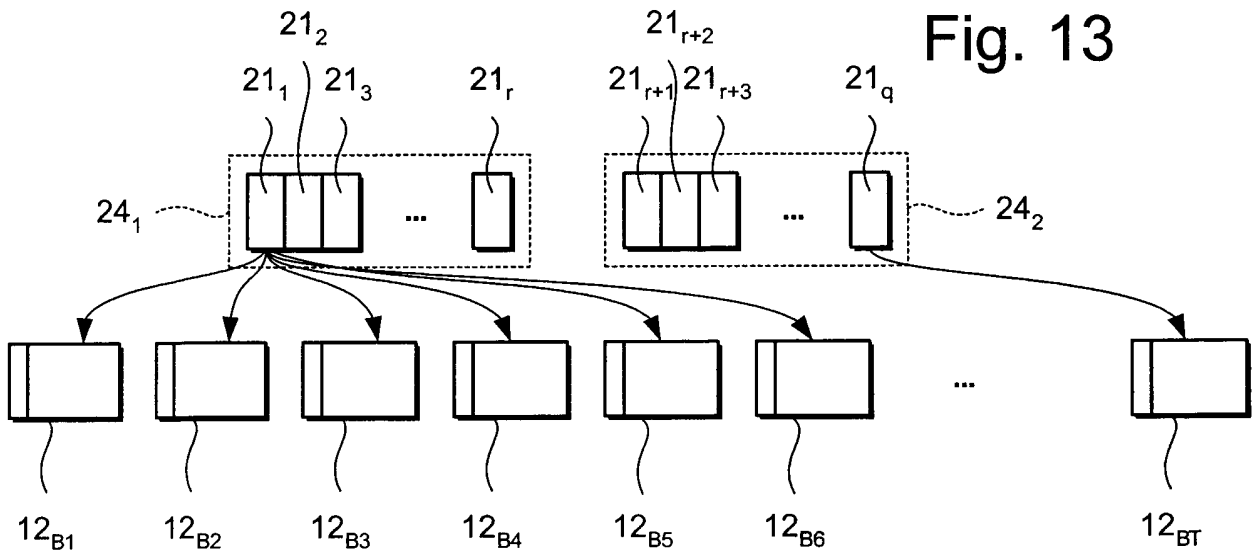

Fig. 14

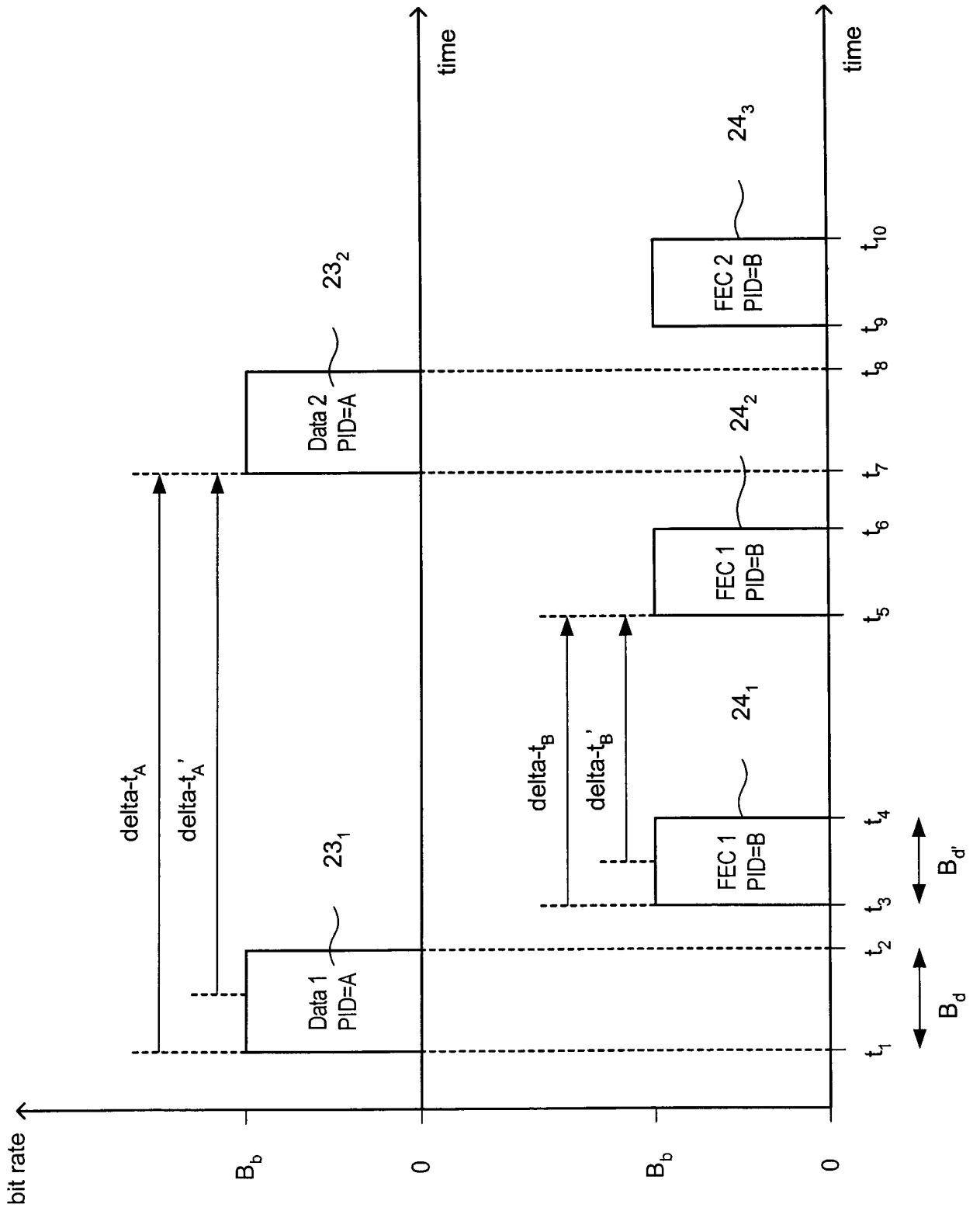

Fig. 12

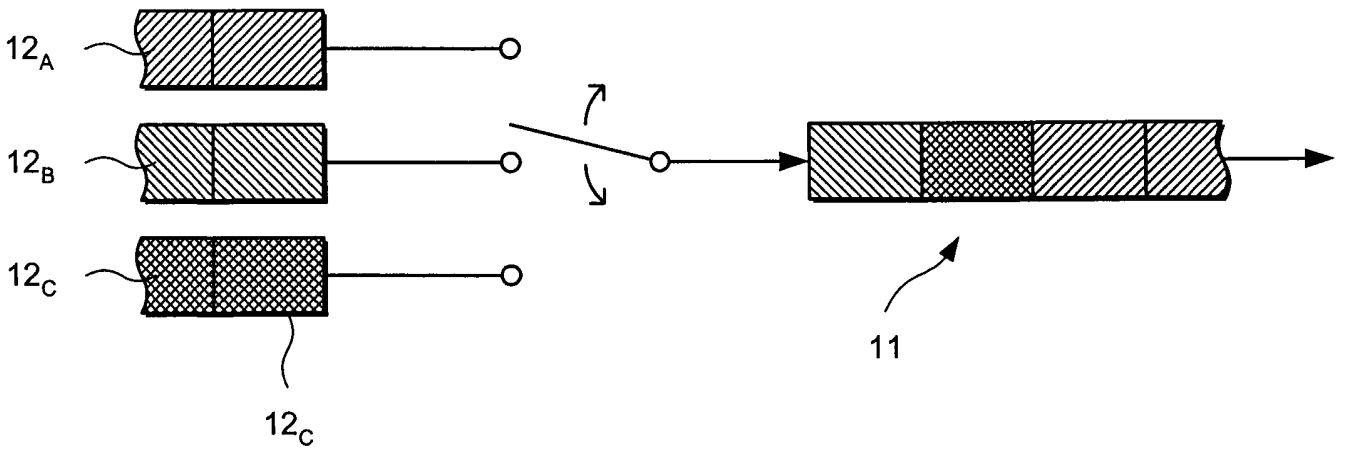

Fig. 15

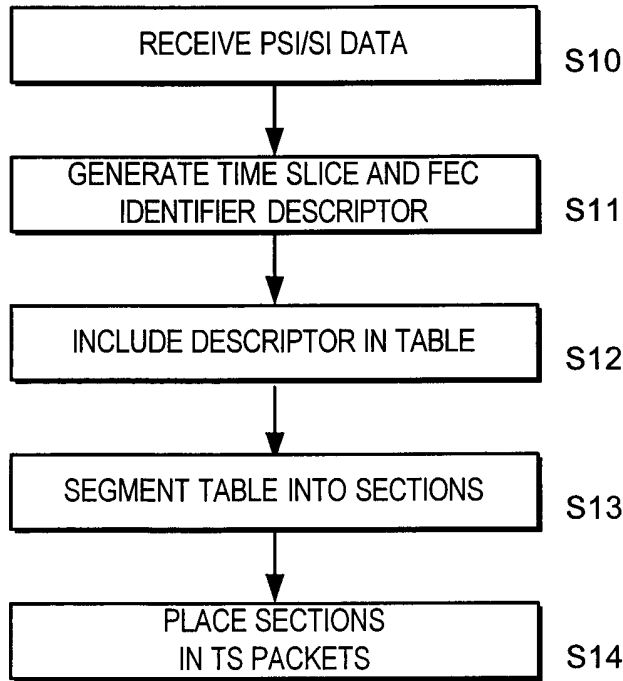

Fig. 17

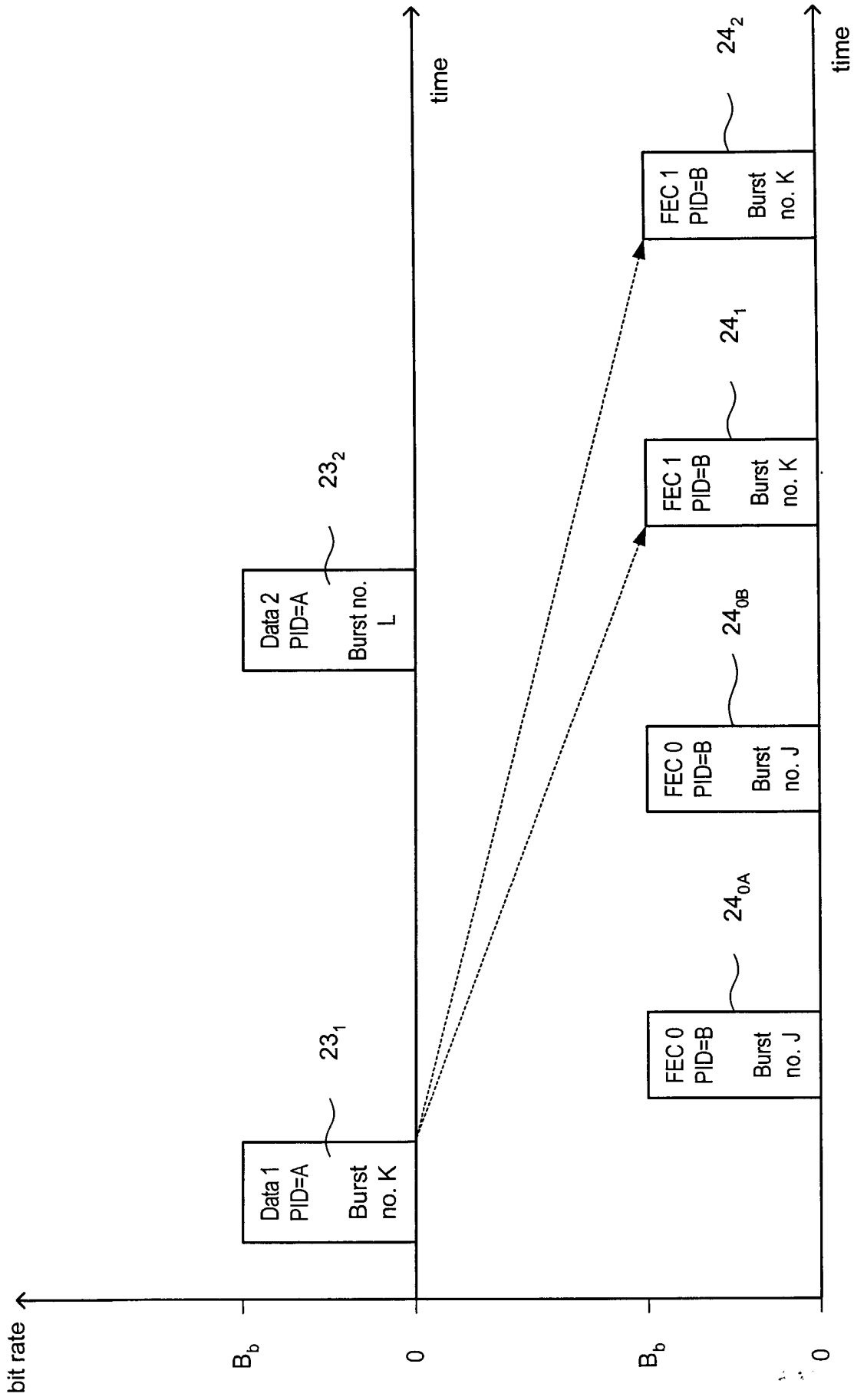

Fig. 16

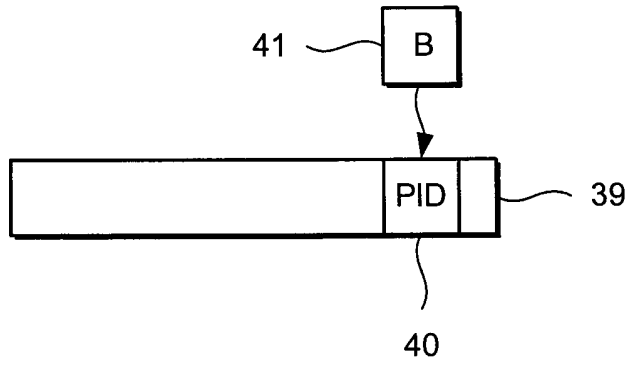

Fig. 18

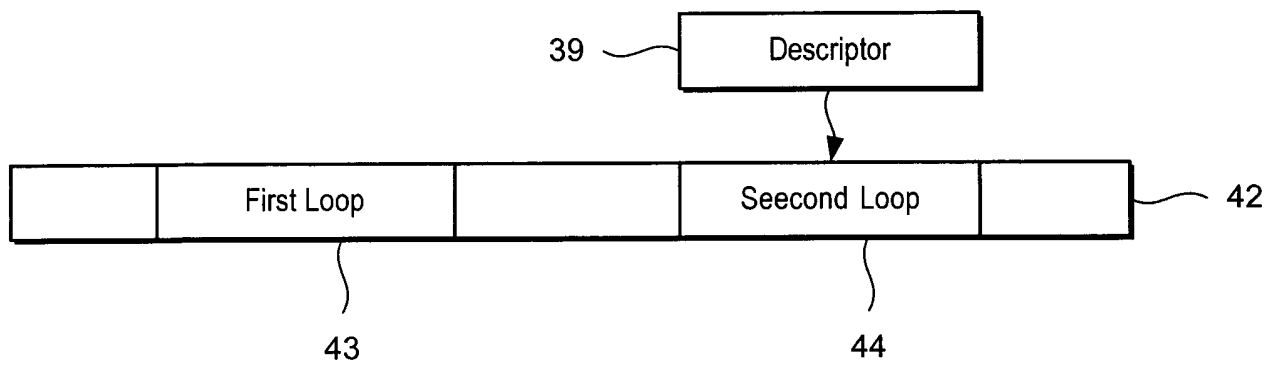

Fig. 19

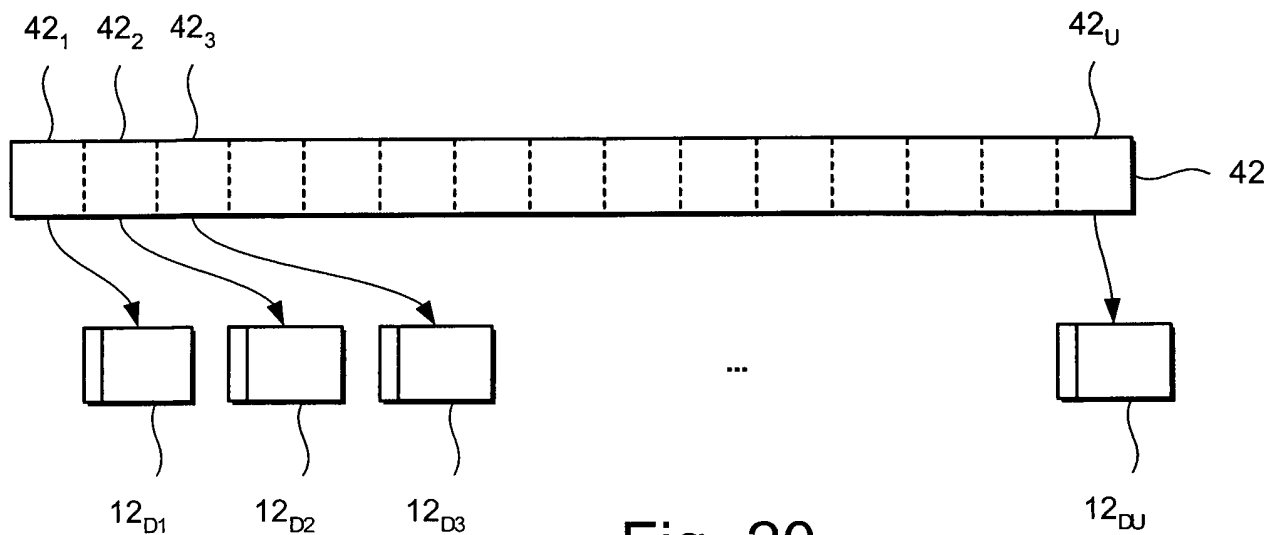

Fig. 20

12/13

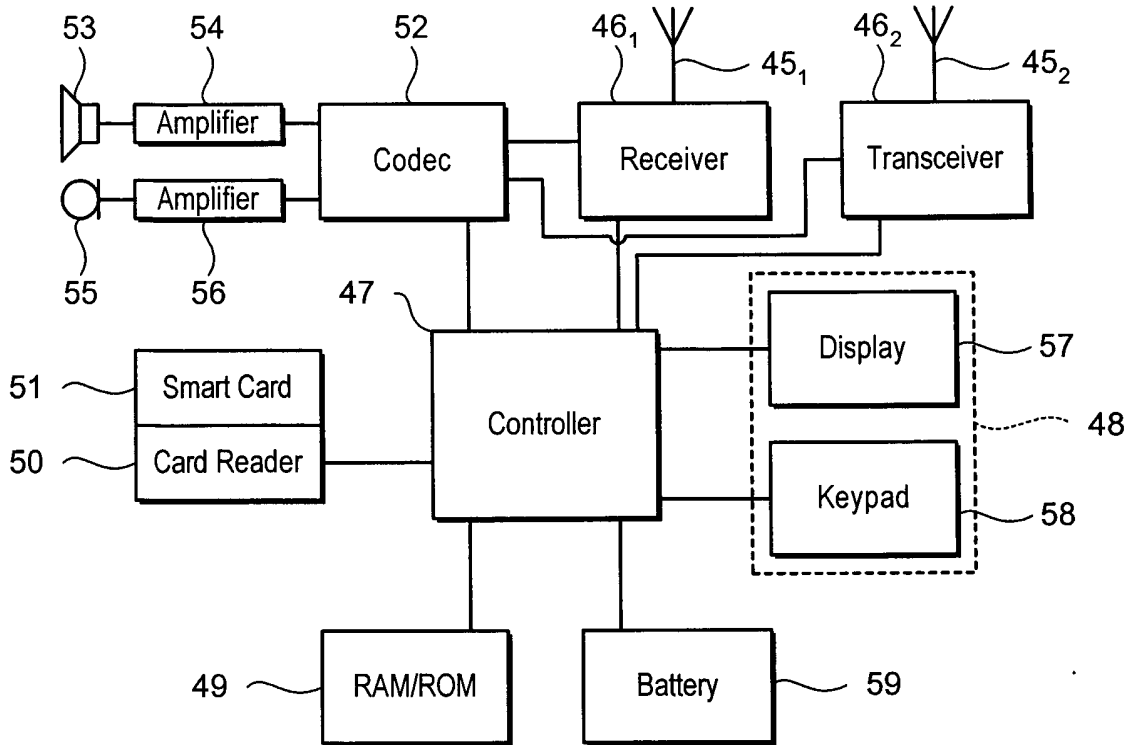

Fig. 21

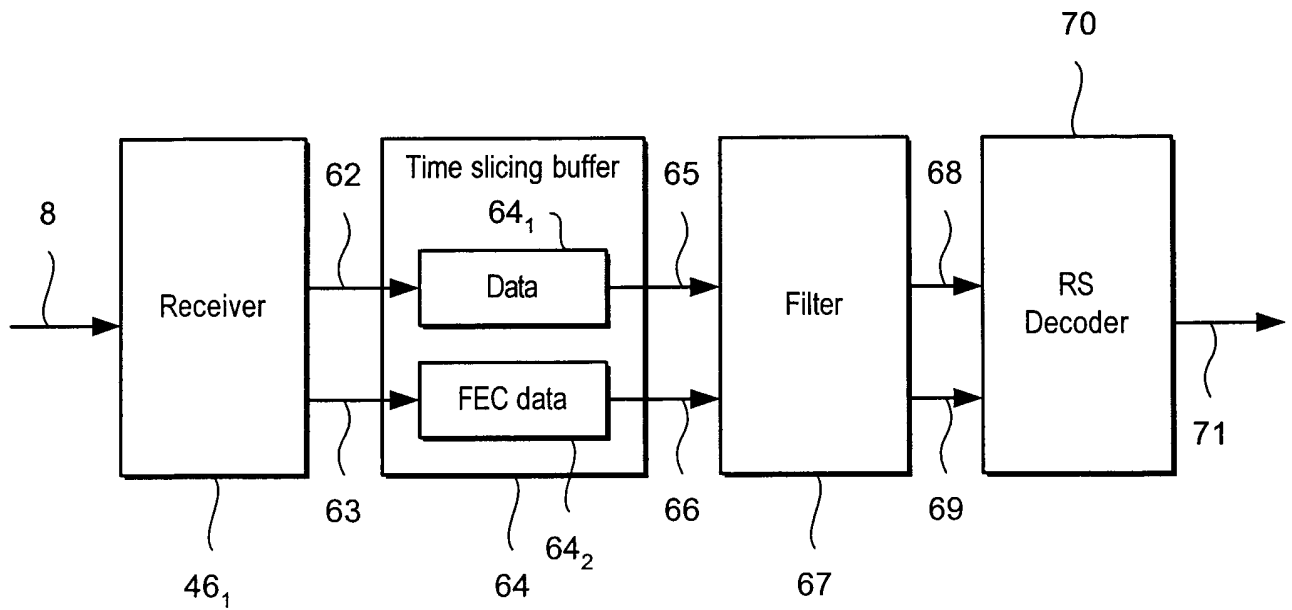

Fig. 22

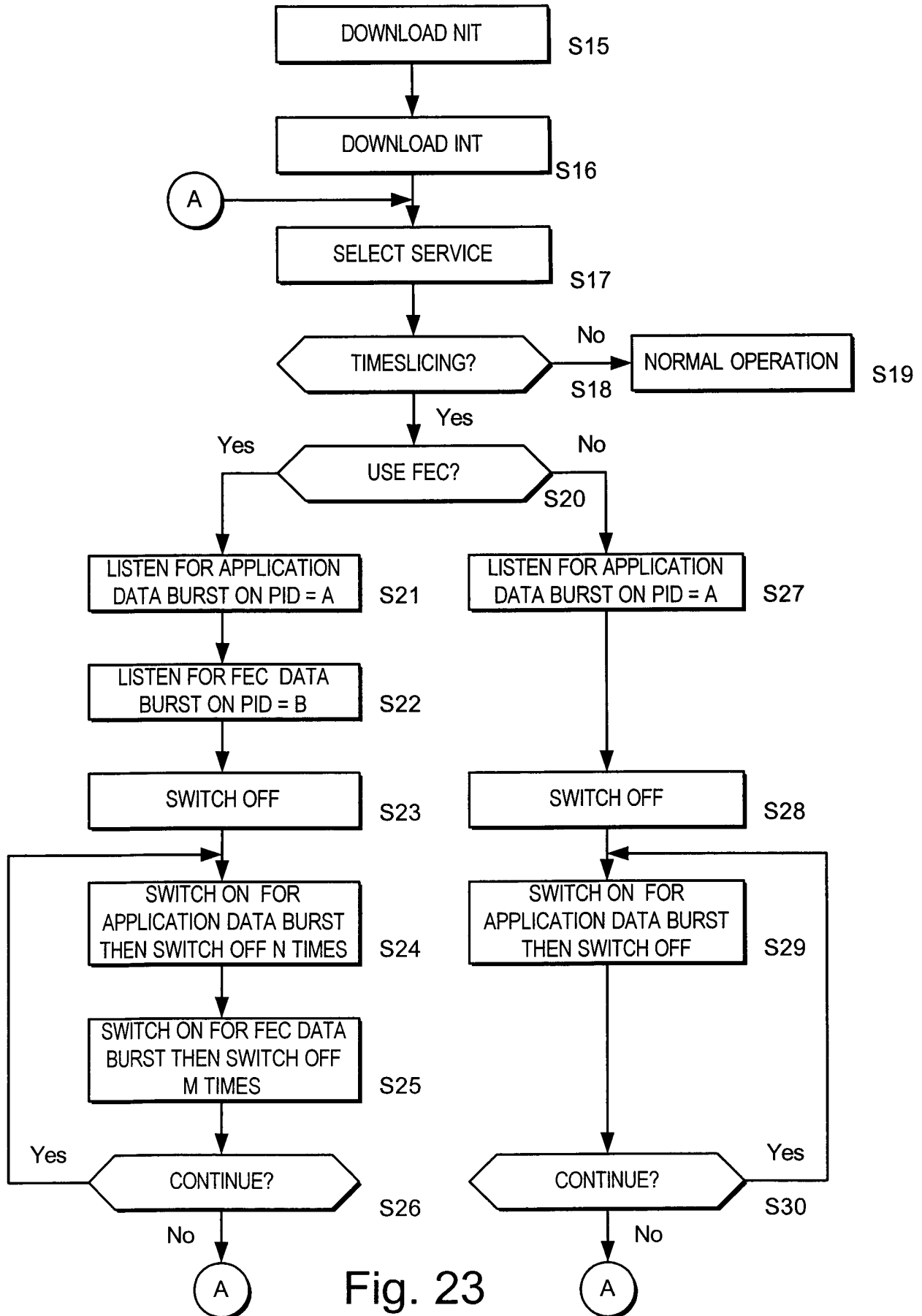

Fig. 23

Burst transmission

Description

The present invention relates to a method of transmitting bursts in a
5 communications system, particularly, although not exclusively, to a method of
transmitting bursts in a digital video broadcasting (DVB) network.

Mobile communications systems are known which can provide enough bandwidth
to allow streaming of video using advanced compression techniques, such as
10 MPEG-4.

DVB receivers are known in applications such as digital television. Usually, DVB
receivers are fixed and mains-powered. However, mobile handheld terminals are
usually battery-powered and so power is limited.

15 The average power consumption of a DVB receiver can be reduced by using a
scheme based on time division multiplexing (TDM). Such a scheme is called time
slicing.

20 If a service is requested, data can be transmitted using time slicing. Bursts of data
are sent using significantly higher bandwidth compared to the bandwidth needed to
send the data at a rate, which is appropriate for direct use or rendering. Each burst
includes an indication of time to the beginning of the next burst, which is referred
to as "delta-t". Between bursts, data is not transmitted, allowing other services to
25 use the bandwidth allocated to the service. Thus, the receiver need only stay active
for a portion of time while receiving bursts. Nevertheless, received bursts can be
buffered and consumed at a rate intended for use or rendering.

In most DVB transmission systems, such as terrestrial DVB (DVB-T), data is
30 transmitted unidirectionally to receivers. Forward error correction may be included
in the transmitted data to recover data. However, the receiver may not be
configured for forward error correction or for a particular forward error correction
scheme.

The present invention seeks to ameliorate this drawback and/or to provide a method of transmitting bursts.

5 According to a first aspect of the present invention there is provided a method of transmitting bursts in a communications network, the method comprising providing data for transmission, providing forward error correction (FEC) data for said data, forming a first set of bursts comprising transmission data and forming a second set of bursts comprising FEC data.

10

This can have the advantage that a receiver can selectively choose whether to receive FEC data.

The method may comprise transmitting said first set of bursts via a first channel, and transmitting said second set of bursts via a second, different channel. The method may comprise providing a first parameter for indicating a timing offset between a first, earlier burst comprising at least some of said transmission data and a second, later burst comprising further transmission data, providing a second parameter for indicating a timing offset between a third, earlier burst comprising at least some of said FEC data and a fourth, later burst comprising further FEC data, forming said first burst including said first timing parameter and forming said third burst including said second timing parameter. The at least some of said transmission data may comprise some of said transmission data and the further transmission data comprises some more of said transmission data. Alternatively, the at least some of said transmission data comprises all of said transmission data and the further transmission data may comprise additionally provided transmission data. The at least some of said FEC data may comprise some of said FEC data and said further FEC data may comprise some more of said FEC data. The at least some of said FEC data comprises all of said FEC data and the further FEC data may comprise some additionally provided FEC data.

30

The method may further comprise dividing said first burst between a first set of packets, identifying each of said first set of packets with a first identity, dividing

said third burst between a second set of packets and identifying each of said second set of packets with a second identity. The first and second identities may be the same. The method may comprise dividing said second burst between a third set of packets; wherein providing said first timing parameter may comprise specifying a
5 time until a start of a first one of said third set of packets. The method may comprise dividing said fourth burst between a fourth set of packets; wherein providing said second timing parameter comprises specifying a time until a start of a first one of said fourth set of packets. The method may comprise preparing service information and including said second identity in said service information. The
10 method may comprise including said second identity in a descriptor and including said descriptor in a table forming part of said service information. The transmission data may comprise a plurality of data packets, and said method may comprise placing at least some of data packets in respective ones of a first set of sections. The method may comprise including said first timing parameter in at least one of
15 said first set of sections. The method may comprise calculating a timing parameter for each section based on said first timing parameter and including a respective timing parameter in each of said first set of sections. The FEC data may comprises a plurality of data packets, and the method may comprise placing at least some of data packets in respective ones of a second set of sections. The method may
20 comprise including said second timing parameter in at least one of said second set of sections. The method may comprise calculating a timing parameter for each section based on said second timing parameter and including a respective timing parameter in each one of said second set of sections.

25 The method may comprise providing a first parameter for identifying a burst comprising at least some of said transmission data, providing a second parameter for identifying at least one burst comprising FEC associated with said at least some of said transmission data, forming a first burst including said first identifying parameter and forming a second burst including said second identifying parameter.

30

The method may comprise labelling at least one burst of said first set of bursts with an identifier and labelling at least one burst of said second set of bursts with a corresponding identifier, preferably the same identifier.

This can help interleaving of said first and second sets of bursts since FEC data for corresponding transmission data can be found.

5 According to a second aspect of the present invention there is provided a method of internet protocol datacasting over a digital broadcasting network using the method.

10 According to a third aspect of the present invention there is provided a computer program comprising computer program instructions for causing data processing means to perform the method.

15 According to a fourth aspect of the present invention there is provided a system of transmitting bursts in a communications network comprising providing data for transmission, providing forward error correction (FEC) data for said data, forming a first set of bursts comprising transmission data and forming a second set of bursts comprising FEC data.

20 According to a fifth aspect of the present invention there is provided a network element comprising means for providing data for transmission, means for providing forward error correction (FEC) data for said data, means for forming a first set of bursts comprising transmission data and means for forming a second set of bursts comprising FEC data.

25 According to a sixth aspect of the present invention there is provided a multiprotocol encapsulator comprising an input for providing data for transmission, a processor for providing forward error correction (FEC) data for said data, a processor for forming a first set of bursts comprising transmission data and a processor for forming a second set of bursts comprising FEC data.

30 According to a seventh aspect of the present invention there is provided a terminal for receiving bursts from a communications network comprising means for receiving a first set of bursts comprising transmission data and means for receiving

a second set of bursts comprising forward error correction (FEC) data for said transmission data.

Embodiments of the present invention will now be described by way of example
5 with reference to the accompanying drawings in which:

Figure 1 shows an embodiment of a communication system according to the present invention;

Figure 2 shows a multiprotocol encapsulation (MPE) encapsulator which outputs
transport stream packets carrying time-sliced bursts in accordance with one
10 embodiment of the present invention;

Figure 3 illustrates an exemplary transport stream packet;

Figure 4 is a schematic diagram of an embodiment of an MPE encapsulator in accordance with the present invention;

Figure 5 is a process flow diagram of a first process performed by the MPE
15 encapsulator shown in Figure 4 in accordance with the present invention;

Figures 6a, 6b and 6c show a process by which forward error correction (FEC) data is calculated in one embodiment of the present invention;

Figure 7 shows application data packets being placed in MPE sections in one embodiment of the present invention;

20 Figure 8 shows FEC data packets being placed in FEC sections in one embodiment of the present invention;

Figure 9 illustrates an example of a section;

Figure 10 illustrates an exemplary application data burst;

Figure 11 illustrates exemplary FEC data bursts;

25 Figure 12 shows transmission of application data bursts and FEC data bursts in one embodiment of the present invention;

Figure 13 illustrates exemplary encapsulation of MPE sections in transport stream packets;

30 Figure 14 illustrates exemplary encapsulation of FEC sections in transport stream packets;

Figure 15 shows exemplary multiplexing of transport stream packets;

Figure 16 shows transmission of application data bursts and FEC data bursts with variable interleaving length in accordance with one embodiment of the present invention

Figure 17 is a process flow diagram of a second process performed by the MPE encapsulator shown in Figure 4 in one embodiment of the present invention;

Figure 18 shows specification of a PID in a time slice and FEC descriptor in accordance with one embodiment of the present invention;

Figure 19 illustrates inclusion of the time slice and FEC descriptor of Figure 18 into a Network Interface Table;

Figure 20 illustrates segmentation of the Network Interface Table shown in Figure 19 and mapping into transport stream packets in accordance with the present invention;

Figure 21 is a schematic diagram of a mobile telephone handset in accordance with the present invention;

Figure 22 shows functional elements of the mobile telephone handset of Figure 21 for receiving and processing time-sliced bursts; and

Figure 23 is process flow diagram of a process of preparing for, receiving and processing time-sliced bursts performed by the mobile telephone handset shown in Figure 21.

20

Communication network 1

Referring to Figure 1, a communications network 1 for delivering content to a mobile terminal 2 is shown. The communications network 1 includes a terrestrial digital video broadcasting (DVB-T) or handheld digital video broadcasting (DVB-H) network which is used as a broadcast access network to deliver content as an Internet Protocol Data Casting (IPDC) service. However, other digital broadcast networks may be used including other types of DVB networks, such as a cable DVB network or satellite DVB network, a Digital Audio Broadcasting (DAB) network or an Advance Television System Committee ATSC) network or a terrestrial Integrated Services Digital Broadcasting-Terrestrial (ISDB-T) network.

30

The communications network 1 includes sources 3₁, 3₂ of content, for example in the form of video, audio and data files, a content provider 4 for retrieving, re-

formatting and storing content, a datacast service system server 5 for determining service composition, a multi-protocol encapsulation (MPE) encapsulator 6 and a transmitter 7 for modulating and broadcasting a signal 8 to receivers (not shown) including mobile terminal 2.

5

Referring to Figure 2, the MPE encapsulator 6 receives a stream of data 9 and service information data 10, such as MPEG program specific information (PSI) and DVB service information (SI), and generates a transport stream 11 comprising MPEG-2 transport stream (TS) packets 12, 12₁, 12₂ typically 188 bytes long,
10 according to International Organisation for Standards/ International Electrotechnical Commission (ISO/IEC) Standard 13818-1 "Information Technology-Generic coding of moving pictures and associated audio information: Systems".

15 The MPE encapsulator 6 may receive a plurality of streams (not shown) and divide, combine and recombine them to form one or more new stream. Each stream may result in one or more application data bursts. Formation of application bursts will be described in more detail later.

20 Referring also to Figure 3, the transport stream 11 is divided into a number of logical channels, referred to as "elementary streams". The elementary stream to which a TS packet 12 belongs is defined in a packet header 13 using a packet identifier (PID) 14. The packet identifier 14 can be used to identify contents of a TS packet payload 15.

25

For example, the contents of a first TS packet 12₁ may be identified as containing all or part of a network information table (NIT) by specifying PID = 0x0010 (as a hexadecimal number). The contents of a second TS packet 12₂ may be identified as being video, audio or another type of data by specifying a PID value between
30 0x0030 to 0x1FFE (as hexadecimal number).

A channel for time-sliced burst transmission, time slicing channel, comprises transmission time periods. During these transmission time periods, time slicing

bursts are transmitted and the time for the next burst, referred to as “delta-t”, is signalled. Delta-t is not necessarily fixed. Between transmission periods, other time slicing channels can be transmitted. Each time slicing channel has their own PID value. It is also possible to multiplex two or more time slicing channels into one time period, because they can be separated (demultiplexed) according to the PID value.

Referring again to Figure 1, the DVB transmitter 7 receives a signal from the encapsulator 6 which it modulates, amplifies and broadcasts.

10

Other network elements may be provided, such as a multiplexer (not shown) for combining a plurality of services and a gap-filler transmitter for receiving and re-transmitting the signal 8. Furthermore, another communications network (not shown), such as a public land mobile network preferably in the form a 2nd or 3rd generation mobile network such as GSM or UMTS respectively, may be provided for providing a return channel from the mobile terminal 8 to the communications network 1. A further communications network (not shown), such as the Internet, may be provided to connect distributed elements of the communications network 1, such as content provider 4 and service system server 5.

20

MPE encapsulator 6

Referring to Figure 4, the MPE encapsulator 6 is shown in more detail.

The MPE encapsulator 6 comprises means 16 for generating from the stream of data 9 forward error correction (FEC) data which outputs a stream 17 of application data packets and a stream or set 18 of FEC data packets, means 19 for placing data 17, 18 in sections which outputs a stream of application data sections 20 and FEC data sections 21 and means 22 for arranging sections and assembling them into bursts 23 comprising application data and bursts 24 comprising FEC data. The MPE encapsulator 6 also comprises means 25 for placing sections including sections 26 comprising service data generated by a controller 27 from service information data 10 into transport stream packets and multiplexing transport stream packets into

30

a single transport stream 11. The controller 27 may also manage operation of the other means 16, 19, 22, 25.

The MPE encapsulator may be implemented in software using a personal computer or in hardware. It will be appreciated that a number microprocessors or digital
5 signal processors may be used.

Operation of the MPE encapsulator 6 will now be described in more detail:

10 FEC data generating means 16

Referring to Figure 5 and 6a, the forward error codes generating means 16 receives the stream 9 of data packets $9_1, 9_2, 9_3, 9_4, 9_m$, in the form of IP datagrams, from the datacast service system server 5 (Figure 1) and, if necessary, pre-processes them by
15 arranging them in order and/or dropping selected data packets, for example based on IP address (step S1). It will be appreciated that the MPE encapsulator 6 may receive Ethernet frames (not shown) and thus, additional processing, such as removing Ethernet frame structure, may be required.

The FEC generating means 16 generates application data 17 and FEC data 18 for
20 the data packets $9_1, 9_2, 9_3, 9_4, 9_m$ (step S2) in a form such as Reed-Solomon (RS) data.

The data packets $9_1, 9_2, 9_3, 9_4, 9_m$ are stored in a coding table or array 29. The data packets $9_1, 9_2, 9_3, 9_4, 9_m$ are stored sequentially in columns $30_1, 30_2, 30_3, 30_4, 30_m$ in a portion of the table 29 referred to as the application data table 31 which in this case
25 occupies the left-most portion of the table 29.

In this example, one data packet 9_1 occupies one column 30_1 . However, one data packet 9_1 may occupy two columns $30_1, 30_2$ or any whole number of columns $30_1, 30_2, 30_3, 30_4, 30_m, 30_n$. One data packet 9_1 need not occupy a whole number of
30 columns $30_1, 30_2, 30_3, 30_4, 30_m, 30_n$ but may only partially occupy one column 30_1 with the remaining, unoccupied portion of the column being filled with padding bits (not shown) and/ or at least part of one or more other data packets $9_2, 9_3, 9_4, 9_m$. Thus, a data packet 9_1 may be divided between two or more columns $30_1, 30_2$.

Alternatively, one data packet 9_1 may occupy a whole number of columns $30_1, 30_2$ and partially occupy one further column 30_3 . The contents of a data packet $9_1, 9_2, 9_3, 9_4, 9_m$ can occupy one or more addressable storage locations of one or more columns $30_1, 30_2, 30_3, 30_4, 30_m, 30_n$.

5

In this example, there are not enough data packets $9_1, 9_2, 9_3, 9_4, 9_m$ to fill the application data table 31. Therefore, any unfilled column 30_n is filled with a column's-worth of padding 32_1 .

10 Referring to Figure 6b, once a given number of data packets $9_1, 9_2, 9_3, 9_4, 9_m$ have been stored or the application data table 31 has been filled, FEC row data $33_1, 33_2, 33_3, 33_p$ is calculated. The FEC row data $33_1, 33_2, 33_3, 33_p$, preferably in the form of Reed-Solomon data, is calculated for each row $34_1, 34_2, 34_3, 34_p$ and entered into a portion of the table 29 referred to as the Reed-Solomon data table 35.

15

In one embodiment of the invention, the coding table 29 has 255 columns. For example, the application data table 31 may comprise 191 columns and the Reed-Solomon table 35 may comprise 64 columns. Preferably, the application data table 31 occupies the left-most portion of table 29 and Reed-Solomon table 35 occupies
20 the right-most portion of the table 29. In one embodiment of the invention, the coding table 29 may comprise a selectable number of rows, up to 1024 rows. Preferably, the table 29 comprises one-byte addressable elements. Thus, a table with 255 columns and 1024 rows may store up to 2 Mbits of data.

25 In one embodiment of the invention, the data packets $9_1, 9_2, 9_3, 9_4, 9_m$ are stored sequentially in rows, wherein the padding is also applied to rows, and FEC column data (not shown) calculated for each column. In other words, rows and columns are interchangeable. It will also be appreciated that the length or size of data packets $9_1, 9_2, 9_3, 9_4, 9_n$ can vary. The data packets $9_1, 9_2, 9_3, 9_4, 9_n$ may be an uneven size.
30 The padding 32_1 may be omitted when calculating FEC row data $33_1, 33_2, 33_3, 33_p$.

Data within the completed coding table 29 may be referred to as an "MPE-FEC frame".

Referring to Figure 6c, application data packets $17_1, 17_2, 17_3, 17_4, 17_m, 17_n$ and FEC data packets $18_1, 18_2, 18_q$ are read out of the coding table 29. The FEC data packets $18_1, 18_2, 18_q$ are read out column by column and so each packet comprises a portion
5 of plural FEC row data $33_1, 33_2, 33_3, 33_p$.

In one embodiment of the invention, the application data packets $17_1, 17_2, 17_3, 17_4, 17_m, 17_n$ are read out of the table, preferably as they are written into it, and forwarded before the FEC row data $33_1, 33_2, 33_3, 33_p$ are calculated. Copies of the
10 application data $17_1, 17_2, 17_3, 17_4, 17_m, 17_n$ are left in the table for the FEC calculation. After FEC row data $33_1, 33_2, 33_3, 33_p$ has been calculated and FEC data packets $18_1, 18_2, 18_q$ are read out and the table can be emptied.

It will be appreciated that if no stuffing data is used then the application data
15 packets $17_1, 17_2, 17_3, 17_4, 17_m, 17_n$ simply comprise the data packets $9_1, 9_2, 9_3, 9_4, 9_n$. Even if stuffing data is used, any column 30_n comprising padding data need not be transmitted.

The process of filling the coding table 29, calculating FEC row data $33_1, 33_2, 33_3, 33_p$ and emptying the coding table 29 is then repeated for the next set of data 9.
20

Formatting means 19

Referring to Figures 4, 5, 7 and 8 the formatting means 19 generates MPE sections
20 comprising application data packets $17_1, 17_2, 17_3, 17_m, 17_n$ and FEC sections 21 comprising FEC data packets $18_1, 18_2, 18_q$ preferably in accordance with Section 7
25 of European Telecommunications Standards Institute (ETSI) Standard 301 192 "Digital Video Broadcasting (DVB); DVB specification for data broadcasting" V1.3.1 (2003-01) (steps S3 & S4).

Referring to Figure 7, the formatting means 19 places application data packets $17_1, 17_2, 17_3, 17_n$ into MPE sections $20_1, 20_2, 20_3, 20_n$ compliant with the DSM-CC section format, in one embodiment of the present invention using the syntax defined in Table 1 below:
30

Table 1

| Syntax | No. of bits | Identifier |
|--|-------------|------------|
| datagram_section() { | | |
| table_id | 8 | uimsbf |
| section_syntax_indicator | 1 | bslbf |
| private_indicator | 1 | bslbf |
| Reserved | 2 | bslbf |
| section_length | 12 | uimsbf |
| MAC_address_6 | 8 | uimsbf |
| MAC_address_5 | 8 | uimsbf |
| Reserved | 2 | bslbf |
| payload_scrambling_control | 2 | bslbf |
| address_scrambling_control | 2 | bslbf |
| LLC_SNAP_flag | 1 | bslbf |
| current_next_indicator | 1 | bslbf |
| section_number | 8 | uimsbf |
| last_section_number | 8 | uimsbf |
| MAC_address_4 | 8 | uimsbf |
| MAC_address_3 | 8 | uimsbf |
| MAC_address_2 | 8 | uimsbf |
| MAC_address_1 | 8 | uimsbf |
| if (LLC_SNAP_flag == "1") { | | |
| LLC_SNAP() | | |
| } else { | | |
| for (j=0;j<N1;j++) { | | |
| IP_datagram_data_byte | 8 | bslbf |
| } | | |
| } | | |
| if (section_number == last_section_number) { | | |
| for (j=0;j<N2;j++) { | | |
| stuffing_byte | 8 | bslbf |
| } | | |
| } | | |
| if (section_syntax_indicator == "0") { | | |
| Checksum | 32 | uimsbf |
| } else { | | |
| CRC_32 | 32 | rpchof |
| } | | |
| } | | |

In one embodiment of the invention, each application data packet 17₁, 17₂, 17₃, 17_n is placed in a corresponding MPE section 20₁, 20₂, 20₃, 20_n, for example as illustrated in Figure 7.

Referring to Figure 8, the formatting means 19 places FEC data packets 18₁, 18₂, 18_q into so-called FEC sections 21₁, 21₂, 21_q compliant with the DSM-CC section

format, in one embodiment of the present invention using the syntax defined in Table 2 below:

Table 2

| Syntax | No. of bits | Identifier |
|--------------------------|-------------|------------|
| FEC_section () { | | |
| table_id | 8 | uimsbf |
| section_syntax_indicator | 1 | bslbf |
| reserved_for_future_use | 1 | bslbf |
| Reserved | 2 | bslbf |
| section_length | 12 | uimsbf |
| padding_columns | 8 | uimsbf |
| reserved_for_future_use | 8 | bslbf |
| Reserved | 2 | bslbf |
| reserved_for_future_use | 5 | bslbf |
| current_nect_indicator | 1 | bslbf |
| section_number | 8 | uimsbf |
| last_section_number | 8 | uimsbf |
| real_time_parameters() | | |
| for(i=0; i<N; i++) { | | |
| rs_data_byte | 8 | uimsbf |
| } | | |
| CRC_32 | 32 | uimsbf |
| } | | |

5

In one embodiment of the invention, each FEC data packet 18₁, 18₂, 18_q is placed in a corresponding FEC section 21₁, 21₂, 21_q.

Referring to Figure 9, the general structure of an MPE section 20 or an FEC section
 10 21 is shown. A section 20, 21 comprises a header 36, a payload 37 and a trailer 38. For an MPE section 20₁, 20₂, 20₃, 20_n, the payload 37 includes an application data packet 17₁, 17₂, 17₃, 17_n (Figure 7). For an FEC section 21₁, 21₂, 21_q, the payload 37 includes a FEC data packet 18₁, 18₂, 18_q (Figure 8).

15 Burst assembling means 22

In a conventional DVB network, data for a given service (or set of services) are transmitted continuously in a logical channel, usually at a rate appropriate for consuming the service. For example, if the service is a video streaming service, video data is transmitted at a rate which allows the video data to be rendered as-
 20 and-when it is received at a receiver.

In an embodiment of a DVB network according to the present invention, data for a given service (or set of services) are transmitted in bursts in a logical channel. The channel can be referred to as a "time slice channel". Between bursts, no data for the service is transmitted in the time slice channel. Nevertheless, between bursts,
5 data for other services may be transmitted, for example in another channel.

It is noted that the logical channel is time sliced. This may be in addition to dividing a physical channel into time slots and assigning each logical channel to a time slot.

10

In a time slice channel, data bursts are transmitted at a higher (instantaneous) peak bit rate than data transmitted continuously in a conventional channel. Preferably, all or a majority of the available bandwidth is used to when transmitting a burst.

15 Time slicing has advantages. For example, a receiver can be switched off between bursts, thereby saving power. Also, the receiver can monitor transmissions in neighbouring cells between bursts so that the receiver can make a handover if necessary seemingly without interruption.

20 As will be explained in more detail later, in one embodiment of the invention, receivers are notified that time slicing is being used e.g. through a network information table (NIT) or through an IP/MAC Notification Table (INT).

Once notified that time slicing is being used, receivers can switch off between
25 bursts. However, in order to do so, they need information regarding when to expect bursts. This can be achieved by including, in each burst, information on the time to the beginning of the next burst, which is referred to as "delta-t". In one embodiment of the invention, delta-t is defined as the time from the end of one burst to the beginning of the next burst. In another embodiments of the invention,
30 delta-t may be defined as the time from the beginning of one burst to the beginning of the next burst or a time from the end of one burst to the end of the next burst. In yet another embodiment of the invention, delta-t information may be given in one or more sections within a burst and delta-t is defined as the time from the

beginning of the section to the beginning of the next burst. Preferably, no bursts for the service will be transmitted within the announced duration of delta-t. Other information about bursts, such as the duration of the burst, can also be included and is referred to as “real-time parameters”.

5

In an embodiment of the present invention, MPE sections 20 carrying application data 17 are assembled into a first set of bursts 23 (only one shown) and FEC sections 21 carrying FEC data 18 are assembled into a second, different set of bursts 24.

10

Referring to Figures 4, 5, 6c, 7 and 10, the burst assembling means 22 arranges the MPE sections 20₁, 20₂, 20₃, 20_n carrying application data 17₁, 17₂, 17₃, 17₄, 17_m, 17_n into an application burst 23₁ (step S5). MPE sections 20₁, 20₂, 20₃, 20_n may be sent in one or more a plurality of bursts.

15

Referring to Figures 4, 5, 6c, 8 and 11, the burst assembling means 22 arranges the FEC sections 21₁, 21₂, 21₃, 21_r and FEC sections 21_{r+1}, 21_{r+2}, 21_{r+3}, 21_q into first and second FEC bursts 24₁, 24₂ respectively (step S6). Alternatively, FEC sections 21₁, 21₂, 21₃, 21_r, 21_{r+1}, 21_{r+2}, 21_{r+3}, 21_q may be assembled into a single burst or divided

20

between three or more bursts.

The burst assembling means 22 includes real time parameters in MAC_address_1 to MAC address_4 fields of each header 36 (Figure 9) as defined in Table 1 or 2 above of each MPE section 20₁, 20₂, 20₃, 20_n and each FEC sections 21₁, 21₂, 21_q. For

25 example, Table 3 below shows real time parameter syntax in one embodiment of the invention:

Table 3

| Syntax | No. of bits | Identifier |
|------------------------|-------------|------------|
| realtime paramters() { | | |
| delta_t | 12 | uimsbf |
| table_boundary | 1 | bslbf |
| burst_boundary | 1 | bslbf |
| Address | 18 | uimsbf |
| } | | |

In one embodiment of the present invention, MAC_address_5 field is used to indicate a burst number. An application data burst can be assigned a burst number and a corresponding FEC data burst can be assigned the same burst number. This allows a receiver to identify to which application data burst one or more FEC data burst corresponds. This has an advantage of allowing interleaving depth to be increased. This will be explained in more detail later.

Referring also to Figure 12 and taking the example of the application burst 23₁, in one embodiment of the invention the delta_t field indicates the time from the beginning of one section within an application burst 23₁ to the beginning of the next application burst 23₂. In this embodiment of the invention a value of delta-t is included in all MPE sections 20₁, 20₂, 20₃, 20_m, 20_n within the burst 23₁ and so the value may differ from section to section. Thus, for the first section 20₁ the value is delta_t_A and for a later section 20₂, 20₃, 20_m, 20_n the value is delta_t_A', wherein delta_t_A > delta_t_A'.

In one embodiment of the invention, resolution of the delta-t is 10 ms. For example, a value 0xC00 (in hexadecimal) = 3072 (in decimal) indicates that the time to the beginning of the next burst is 30.72 s. The value 0x00 is reserved to indicate that no more bursts will be transmitted within the elementary stream, in other word to indicate end of service. In such a case, all MPE sections 20₁, 20₂, 20₃, 20_m, 20_n within the burst 23₁ have the same value in this field.

Further in one embodiment of the invention, delta-t is defined from the TS packet 12_{A1} (Figure 13) carrying the first byte of the current MPE section (not shown) to the TS packet (not shown) carrying the first byte of next burst 23₂. Therefore, the value of delta-t can differ between MPE sections 20₁, 20₂, 20₃, 20_m, 20_n within the burst 23₁.

The time indicated by delta-t is beyond the end of the maximum burst duration of the actual burst. This helps to ensure that a decoder can reliably distinguish two sequential bursts within an elementary stream.

In one embodiment of the invention, all the MPE sections 20₁, 20₂, 20₃, 20_n (Figure 7) comprising all the application data 17₁, 17₂, 17₃, 17_m, 17_n (Figure 6c) from the application table 31 (Figure 6c) is comprised in the application burst 23₁ (Figure 10) and not divided between plural application bursts. Furthermore, it is preferable that
5 the burst 23₁ contains complete data packets 17₁, 17₂, 17₃, 17₄, 17_m, 17_n, i.e. that data packets 17₁, 17₂, 17₃, 17₄, 17_m, 17_n are not fragmented between bursts. Also, transmission of empty MPE sections, i.e. an MPE section with no payload, is preferably to be avoided.

10 Each application burst 23₁ may contains at least one MPE section 20₁, 20₂, 20₃, 20₄, 20_n carrying a proper data packet 17₁, 17₂, 17₃, 17₄, 17_m, 17_n containing a network layer address (not shown), which is one of the addresses an IP/MAC Notification Table (INT) has associated with the elementary stream.

15 The table_boundary field is a flag. When the flag is set to "1", it indicates that the current section is the last section of the table. In the case of MPE section, this flag indicates the last section of the application data table. In the case of MPE-FEC section, this flag indicates the last section of the RS data table.

The burst_boundary field is a flag. When the flag is set to "1", it indicates that the
20 current section, either MPE or MPE-FEC section, is the last section within the current burst.

The address field specifies the position, in the corresponding table 29 (Figure 6a), of the first byte of the payload carried within the MPE section 20₁, 20₂, 20₃, 20₄, 20_n.

25 All sections delivering data for a table 29 are delivered in ascending order according to the value of this field. The bytes position is a zero-based linear address within the table 29, starting from the first row of the first column, and increasing towards the end of the column. At the end of the column, the next byte position is at the first row of the next column. Thus, the address field of the first MPE section 20₁
30 of the table 29 contains the value "0" and addressing starts from zero for each table 29.

Taking now the example of the FEC burst 24₁, in one embodiment of the invention, the delta_t field indicates the time from the beginning of one section to the beginning of the next FEC burst 24₂. Preferably, a value of delta-t is included in all FEC sections 21₁, 21₂, 21₃, 21_r within the burst 24₁ and so the value may differ from section to section. Thus, as illustrated in Figure 12 and referring to Figure 11, for the first section 21₁ the value is delta_t_B and for a later section 21₂, 21₃, 21_r the value is delta_t_B', wherein delta_t_B' > delta_t_B'.

Similar to the application burst 23₁ described earlier, the FEC burst 24₁ includes table_boundary field, the burst_boundary field and the address fields.

Encapsulating and multiplexing means 25

Referring to Figures 4, 5, 13 and 14, the encapsulating and multiplexing means 25 places MPE sections 20₁, 20₂, 20₃, 20₄, 20_n into TS packets 12_{A1}, 12_{A2}, 12_{A3}, 12_{A4}, 12_{A5}, 12_{A6}, 12_{AS} having the same PID, for example PID = A, where A is hexadecimal number between 0x0030 to 0x1FFE (step S7).

The encapsulating and multiplexing means 25 places FEC sections 21₁, 21₂, 21₃, 21_r, 21_{r+1}, 21_{r+2}, 21_{r+3}, 21_q into TS packets 12_{B1}, 12_{B2}, 12_{B3}, 12_{B4}, 12_{B5}, 12_{B6}, 12_{BT} having the same PID, for example PID = B, where B is hexadecimal number between 0x0030 to 0x1FFE (step S7).

In one embodiment of the invention, each MPE section 20 and each FEC section 21 is divided between six TS packets 12. In Figures 13 and 14, only the first MPE section 20₁ and the first FEC section 21₁ are shown divided for reasons of clarity. However, a fewer or greater number of TS packets 12 may be used to carry one MPE section 20 or one FEC section 21.

Referring to Figure 15, TS packets 12_A comprising TS packets 12_{A1}, 12_{A2}, 12_{A3}, 12_{A4}, 12_{A5}, 12_{A6}, 12_{AS} (Figure 13) carrying application data 17, TS packets 12_B comprising TS packets 12_{B1}, 12_{B2}, 12_{B3}, 12_{B4}, 12_{B5}, 12_{B6}, 12_{B1} (Figure 14) carrying FEC data 17 and TS packets 12_C carrying other data are multiplexed to form a single stream 11.

Referring again to the example shown in Figure 12, the application burst 23_1 is transmitted followed by FEC bursts $24_1, 24_2$. Thus, all the FEC data $18_1, 18_2, 18_q$ (Figure 6c) for an MPE-FEC frame is transmitted before application data for the
5 next MPE-FEC frame is transmitted.

In an alternative embodiment of the invention, the application bursts $23_1, 23_2$ and FEC bursts $24_1, 24_2$ are generated as described earlier. However, the encapsulating and multiplexing means 25 places the FEC sections $21_1, 21_2, 21_3, 21_r, 21_{r+1}, 21_{r+2},$
10 $21_{r+3}, 21_q$ into TS packets $12_{B1}, 12_{B2}, 12_{B3}, 12_{B4}, 12_{B5}, 12_{B6}, 12_{BT}$ having the same PID as the TS packets $12_{A1}, 12_{A2}, 12_{A3}, 12_{A4}, 12_{A5}, 12_{A6}, 12_{AT}$ carrying application data sections $20_1, 20_2, 20_3, 20_4, 20_m, 20_n$.

The processes described earlier can have one or more advantages.
15

For example, a time interleaving length can be adjusted by changing the time between transmitting application data and FEC bursts.

New coding schemes can be introduced more easily.
20

Robust transmission can be achieved by using codes which can incrementally add FEC columns without limit. Thus, FEC data can be sent in plural bursts between application data bursts. A receiver receives the FEC bursts until it is capable of correcting all errors. This method provides strong coding and long interleaving.
25

Application data and FEC data can be clearly distinguished, thus making it easier to receive only the application data. This can be useful for receivers which are not equipped for FEC.

30 Also, the number of real time parameters may be reduced since parameters relating to FEC may be excluded from application data bursts. As will be explained in more detail later, the PID of the FEC data is signalled in an SI table.

As mentioned earlier, MAC_address_5 field may be used to indicate a burst number. An application data burst can be assigned a burst number and a corresponding FEC data burst can be assigned the same burst number. This allows a receiver to identify to which application data burst one or more FEC data burst corresponds. This has
5 an advantage of allowing interleaving depth to be increased.

Referring to Figure 16, the application burst 23_1 having a burst number K may be transmitted followed by FEC bursts 24_{0A} , 24_{0B} each having burst number J, associated with an earlier application burst (not shown). Application burst 23_2
10 having burst number L can then be transmitted followed by FEC bursts 24_1 , 24_2 having burst number K, associated with application burst 23_1 . Shorter or longer interleaving lengths may be used. It is noted that burst numbering can take into account that two or more FEC bursts may be carrying FEC data for one application data burst.

15 Thus, when an application burst is transmitted, one or more FEC bursts associated with the application burst can be transmitted immediately afterwards (before the next application burst) or later after plural application bursts.

20 Controlling means 27

Referring to Figure 4, the MPE encapsulator 6 receives, modifies and/or prepares PSI/SI and SI data 10 and transmits the data 10 to receivers.

The controlling means 27 generates an IP/MAC Notification Table (INT) (not
25 shown). The INT is used to signal the PID of the TS packets 12_{A1} (Figure 13) carrying application data 17_1 (Figure 6c). In other words, the INT is used to signal the availability and location of the elementary stream with PID = A.

The controlling means 27 segments the INT into sections (not shown) and passes
30 the table sections to the encapsulating and multiplexing means 25 to be mapped into TS packets (not shown) having PID = 0x004C and multiplexed into the transport stream 11 (Figure 2).

The INT is described in more detail in Sections 7.6 of ETSI EN 301 192 “Digital Video Broadcasting (DVB); DVB specification for data broadcasting” V1.2.1 (2003-01).

5 As briefly mentioned earlier, a data broadcast descriptor in a Service Description Table (SDT) transmitted using service description sections indicates that MAC_address 1 to MAC_address 4 fields, and optionally MAC_address 5 field, are not being used to differentiate receivers within an elementary stream but are being used to carry real time parameters, such as delta-t.

10

The service description sections and data broadcast descriptor is described in more detail in Sections 6 and 7 of ETSI EN 300 468 “Digital Video Broadcasting (DVB); Specification for Service Information (SI) in DVB systems” V1.5.1 (2003-01).

15 Referring to Figure 18, a time slice identifier descriptor 39 is shown. In one embodiment of the invention, the syntax of the time slice identifier descriptor 39 is given in Table 4 below:

Table 4

| Syntax | No. of bits | Identifier |
|--|-------------|------------|
| Time slice fec identifier descriptor (){ | | |
| descriptor_tag | 8 | uimsbf |
| descriptor_length | 8 | uimsbf |
| time_slicing | 1 | bslbf |
| mpe_fec | 1 | uimsbf |
| reserved_for_future_use | 1 | uimsbf |
| data_padding_columns | 8 | uimsbf |
| max_burst_duration | 4 | uimsbf |
| max_frame_size | 4 | uimsbf |
| mpe_fec_PID | 13 | uimsbf |
| } | | |

20

According to Table 4 above, the descriptor_tag field is provided with a value agreed specified by a standards organisation. The descriptor_length field specifies the number of bytes immediately following the field. The time_slicing field indicates, whether the elementary stream in question is time sliced. A value “1” indicates that time slicing is being used, while a value “0” indicates that time slicing is not used.
25 The mpe_fec field indicates whether the elementary stream uses MPE-FEC.

The data_padding_columns field specifies the fixed number of padding columns 32₁ (Figure 6b) that are introduced immediately before the end of the application data table 31 (Figure 6b). In one embodiment of the invention, the number of padding
5 columns can take a value between 0 and 190. If the mpe_fec field is set to "0" then the content of the field is ignored.

The max_burst_duration field is used to indicate the maximum burst duration in the concerned elementary stream. A burst does not start before T₁ and does not end
10 later than T₂, where T₁ is the time indicated by delta-t on a previous burst, and T₂ = T₁ + maximum burst duration. In one embodiment of the invention, the indicated value for maximum burst duration preferably lies within a range from 20 ms to 512 s in 20 ms steps. The maximum burst duration = max_burst_duration × 20
15 milliseconds. In one embodiment of the invention, the max_burst_duration field may be encoded according to Table 5 below:

Table 5

| Duration | Description |
|----------|-------------|
| 0000 | 100 ms |
| 0001 | 125 ms |
| 0010 | 150 ms |
| 0011 | 200 ms |
| 0100 | 250 ms |
| 0101 | 300 ms |
| 0110 | 350 ms |
| 0111 | 400 ms |
| 1000 | 500 ms |
| 1001 | 600 ms |
| 1010 | 800 ms |
| 1011 | 1100 ms |
| 1100 | 1500 ms |
| 1101 | 2000 ms |
| 1110 | 3000 ms |
| 1111 | 5000 ms |

The frame_size field is used to give information that a decoder may use to adapt its
20 buffering usage. The exact interpretation depends on whether time slicing and/or MPE-FEC are used.

If the time_slicing field is set to "0", i.e. time slicing is not used, then the frame_size field is reserved for future use and is set to 0x00 when not used. If the

time_slicing field is set to “1”, i.e. time slicing is used, then the frame_size field indicates the maximum number of bits on section level allowed within a time slice burst on the elementary stream. Bits are calculated from the beginning of the table_id field to the end of the CRC_32 field.

5

If the mpe_fec field is set to “1”, i.e. MPE-FEC is used, then the frame_size field indicates the exact number of rows on each MPE-FEC frame on the elementary stream. When both time slicing and MPE-FEC are used on the elementary stream, both limitations (i.e. the maximum burst size and the number of rows) apply. In

10 one embodiment of the invention, Frame_size field may be coded according to Table 6 below:

Table 6

| Size | Max Burst size | MPE-FEC frame rows |
|--------------|-------------------------|-------------------------|
| 0x00 | 128 kbits | 64 |
| 0x01 | 256 kbits | 128 |
| 0x02 | 384 kbits | 192 |
| 0x03 | 512 kbits | 256 |
| 0x04 | 640 kbits | 320 |
| 0x05 | 768 kbits | 384 |
| 0x06 | 896 kbits | 448 |
| 0x07 | 1 024 kbits | 512 |
| 0x08 | 1 152 kbits | 576 |
| 0x09 | 1 280 kbits | 640 |
| 0x0A | 1 408 kbits | 704 |
| 0x0B | 1 536 kbits | 768 |
| 0x0C | 1 664 kbits | 832 |
| 0x0D | 1 792 kbits | 896 |
| 0x0E | 1 920 kbits | 960 |
| 0x0F | 2 048 kbits | 1024 |
| 0x10 to 0x1F | Reserved for future use | Reserved for future use |

15 If the max_frame_size field indicates “reserved_for_future_use”, the receiver assumes that the maximum burst size is greater than 2 Mbits and MPE-FEC frame rows more than 1024.

20 In one embodiment of the invention, time slicing is not used, i.e. MPE-FEC frames are transmitted without any time slicing. A field that supports a cyclic MPE-FEC frame index within the elementary stream can be used for control purposes. The value of the field increases by one for each subsequent MPE-FEC frame. After value “1111111111”, the field restarts from “0000000000”.

The mpe_fec PID field 40 specifies the PID of the elementary stream used to transmit FEC data 18₁, 18₂, 18_q of the elementary stream in question. Thus, for elementary stream with PID = A, the field 40 is filled with a value 41, namely PID = B.

Referring to Figure 19, the time slice identifier descriptor 39 is used in a Network Information Table (NIT) 42 (step S12). In one embodiment of the invention, the syntax of the NIT 42 is shown in Table 7 below:

10

Table 7

| Syntax | No. of bits | Identifier |
|--------------------------------|-------------|------------|
| network_information_section(){ | | |
| table_id | 8 | uimsbf |
| section_syntax_indicator | 1 | bslbf |
| reserved_future_use | 1 | bslbf |
| Reserved | 2 | bslbf |
| section_length | 12 | uimsbf |
| network_id | 16 | uimsbf |
| Reserved | 2 | bslbf |
| version_number | 5 | uimsbf |
| current_next_indicator | 1 | bslbf |
| section_number | 8 | uimsbf |
| last_section_number | 8 | uimsbf |
| reserved_future_use | 4 | bslbf |
| network_descriptors_length | 12 | uimsbf |
| for(i=0;i<N;i++){ | | |
| descriptor() | | |
| } | | |
| reserved_future_use | 4 | bslbf |
| transport_stream_loop_length | 12 | uimsbf |
| for(i=0;i<N;i++){ | | |
| transport_stream_id | 16 | uimsbf |
| original_network_id | 16 | uimsbf |
| reserved_future_use | 4 | bslbf |
| transport_descriptors_length | 12 | uimsbf |
| for(j=0;j<N;j++){ | | |
| descriptor() | | |
| } | | |
| } | | |
| CRC_32 | 32 | rpchof |
| } | | |

When located in a first descriptor loop 43, the descriptor 39 applies to all transport streams announced within the table. The descriptor 39 applies to all elementary

15

streams having a given stream_type field value on any of the transport streams. In one embodiment of the present invention, a stream_type field value of 0x0D is used for elementary streams carrying MPE only streams. A stream_type field value of 0x80 may be used for elementary streams carrying MPE and FEC sections. A
5 stream_type field value of between 0x80 and 0xFF may be used for elementary streams carrying only FEC section.

When located in a second descriptor loop 44, the descriptor 39 applies to the transport stream in question, specified by the transport_stream field. The
10 descriptor applies to all elementary streams having a given stream_type field value. This descriptor 39 overwrites possible descriptors in the first descriptor loop.

In other embodiments of the invention the descriptor 39 may be included in other types of tables, such as in an INT.

15 When located in the platform descriptor loop, the descriptor applies to all elementary streams referred to within the table. This descriptor overwrites possible descriptors in NIT.

20 When located in the target descriptor loop, the descriptor applies to all elementary streams referred within the target descriptor loop in question after the appearance of the descriptor. This descriptor overwrites possible descriptors in the platform descriptor loop and in NIT. In case an elementary stream is referred from multiple locations within an INT, each contains the same signalling.

25 The controlling means 27 generates the NIT 42 including the descriptor 39 in the second descriptor loop 44 indicating PID = B in the mpe_fec PID field 40 (step S12).

30 Referring to Figure 20, the controlling means 27 segments the NIT 42 into table sections 42₁, 42₂, 42₃, 42_U (step S13) and maps them into TS packets 12_{D1}, 12_{D2}, 12_{D3}, 12_{DU}, labeled in this case with PID = 0x0010 and multiplexes the TS packets 12_{D1}, 12_{D2}, 12_{D3}, 12_{DU} into the transport stream 11 (Figure 2) (step S14).

A receiver usually only accesses the NIT 42 when connecting to the network 1 (Figure 1).

5 A receiver may need to read the content of an INT when changing from one transport stream 11 to another (not shown) and usually not more than once. Changes in the INT can be signalled in PSI using a PMT table (not shown), thus ensuring that constant filtering of the INT is not required.

10 PSI tables, such as the INT (not shown) and NIT 42, are usually re-transmitted at least once in every 100 ms. If the duration of a burst is longer than 100 ms, a receiver has access to all PSI tables while receiving a burst. For shorter bursts, a receiver may choose to keep switched on until all required PSI tables are received.

15 *Mobile terminal 2*

Referring to Figure 20, mobile terminal 2 is preferably in the form of a mobile telephone handset with a multimedia capability.

The mobile terminal 2 includes first and second antennae 45₁, 45₂, a receiver 46₁ and
20 a transceiver 46₂. In this example, the first antenna 45₁ and receiver 46₁ are used to receive signals from the communications network 1 (Figure 1), in this case a DVB-T network. The second antenna 45₂ and transceiver 46₂ are used to transmit and receive signals to and from a second communications network, such as a PLMN (not shown). The receiver and transceiver 45₁, 46₂ each include respective r.f. signal
25 processing circuits (not shown) for amplifying and demodulating received signals and respective processors (not shown) for channel decoding and demultiplexing.

The mobile terminal 2 also includes a controller 47, a user interface 48, memory 49, a smart card reader 50, smart card 51 received in the smart card reader 50, a
30 coder/decoder (codec) 52, a speaker 53 with corresponding amplifier 54 and a microphone 55 with a corresponding pre-amplifier 56.

The user interface 48 comprises a display 57 and a keypad 58. The display 57 is adapted for displaying images and video by, for instance, being larger and/or having greater resolution than a display of conventional mobile telephone and being capable of colour images. The mobile terminal 2 also includes a battery 59.

5

The controller 47 manages operation of the mobile terminal 2 under the direction of computer software (not shown) stored in memory 49. For example, the controller 47 provides an output for the display 57 and receives inputs from the keypad 58.

10 The mobile terminal 2 may be modified providing a single receiver adapted to receive signals from the first communications network 1 (Figure 1) and the second communications network (not shown) and a transmitter adapted to transmit signals to the second communications network (not shown). Alternatively, a single transceiver for both communications networks may be provided.

15

Referring to Figure 22, the receiver 46₁ is intermittently switched on to receive the signal 8 from the first communications network 1. The signal 8 is amplified, demodulated, channel decoded and demultiplexed into first and second elementary streams 62, 63.

20

The first elementary stream 62 includes TS packets 12_{A1}, 12_{A2}, 12_{A3}, 12_{A4}, 12_{A5}, 12_{A6}, 12_{AS} (Figure 13) carrying application data bursts 23₁, 23₂ (Figure 12). The second elementary stream 63 includes 12_{B1}, 12_{B2}, 12_{B3}, 12_{B4}, 12_{B5}, 12_{B6}, 12_{BT} (Figure 14) carrying FEC data bursts 24₁, 24₂, 24₃ (Figure 12).

25

The first and second elementary streams 62, 63 are fed into buffering means 64 comprising a first portion 64₁ for buffering application data bursts 23₁, 23₂ (Figure 12) and a second portion 64₂ for buffering FEC data bursts 24₁, 24₂, 24₃ (Figure 12). The buffering means 64 is provided by controller 47 and memory 49. The buffering
30 means 64 outputs first and second streams 65, 66 of sections which are not time sliced. Preferably, the streams 65, 66 are substantially continuous and/or at a substantially constant rate.

The streams 65, 66 are fed into a filtering means 67 which extracts data packets from sections and outputs corresponding streams 68, 69 of data packets.

The first data packet stream 68 ideally comprises application data packets 17₁, 17₂, 17₃, 17₄, 17_m, 17_n (Figure 6c). The second data packet stream 69 ideally comprises
5 FEC data packets 18₁, 18₂, 18_q (Figure 6c). However, errors may have been introduced during transmission.

The streams 68, 69 are fed into a decoder 70 for performing forward error
10 correction and outputting a stream of data packets 71. In this example, the decoder 70 is a Reed-Solomon decoder.

Referring to also Figure 23, an example of a method of operating the mobile terminal 2 will now be described in more detail:

15

When the mobile terminal is switched on by the user, the controller 47 downloads the received, *inter alia*, NIT 42 and INT (not shown) and stores them in memory 49 (steps S15 & S16). The controller 47 downloads other tables, such as PMT and PAT. The tables may have been downloaded at other times and may be downloaded
20 repeatedly.

The user selects a service, such as streaming video (step S17). The controller 47 looks up the PID for the service in the INT (not shown).

25 The controller 47 examines the NIT 42 or other received tables to determine whether time slicing has been enabled for the service (step S18). In another embodiment of the invention the enablement of time-slicing may be announced, for example in NIT. If time slicing is not used, then the controller 47 receives and processes data which is not time-sliced in a conventional manner (step S19).

30

Otherwise, the controller 47 determines whether to use forward error correction (step S20). The determination may be based on e.g. BER (bit error rate) or on received signal strength or on user decision.

If so, the controller 47 begins to listen for application bursts 23 comprised in TS packets with PID = A (step S21). Preferably, the receiver 46₁ remains switched on until it receives at least part of an application burst 23 and thus obtains a value of
5 delta-t_A.

The controller 47 examines mpe_fec PID field 40 (Figure 17) of descriptor 39 (Figure 18) of the received INT and PMT and begins to listen for FEC bursts 24 comprised in TS packets with PID = B (step S22). Preferably, the receiver 46,
10 remains switched on until it receives at least part of an FEC burst 24 and thus obtain a value of delta-t_B.

If no other service is required, the controller 47 instructs the receiver 46₁ to switch off (step S23).
15

Based upon a value of delta-t_A, the controller 47 instructs the receiver 46₁ to switch on when the next application burst 23 expected, receive the application burst 23 and switch off (step S24). This is repeated for N times. Receiving the application burst 23 includes demodulating, decoding and demultiplexing the signal 8 and buffering
20 the application burst 23 in buffering means 64.

Based upon a value of delta-t_B, the controller 47 instructs the receiver 46₁ to switch on when the next FEC burst 24 expected, receive the FEC burst 24 and switch off (step S25). This is repeated for M times. Receiving the FEC burst 24 includes
25 demodulating, decoding and demultiplexing the signal 8 and buffering the FEC burst 23 in buffering means 64. This controller 47 may instruct the receiver 46₁ to switch on and off repeatedly so as to receive plural FEC bursts 24 before switching on again to receive an application burst 23. In order to save power, the FEC bursts may be received only if there is an error detected in the application data burst.

30 If service is still required (step S26), then the controller 47 continues to instruct the receiver 46₁ to switch on and off intermittently to receive interleaved application and FEC bursts 23, 24.

If forward error correction is not required, for example through user choice or because decoder 70 is not provided, the controller 47 instructs the receiver 46₁ to listen for application bursts 23 comprised in TS packets with PID = A (step S 27).

5 Once the controller 47 obtains a value of Δt_A it instructs the receiver 46₁ to switch off and thereafter to switch on when the next application burst 23 expected, receive the application burst 23 and switch off (step S29).

As explained earlier, each MPE section 20 includes a value of Δt_A . The later an
10 MPE section 20 is found in an application burst 23, the smaller the value of Δt_A . Therefore, the controller 47 may repeatedly extract a value of Δt_A from each MPE section 20 and update a value stored in memory 49. Preferably, the processor extracts a value of Δt_A from the last MPE section 20_n (Figure 10) of an application burst 23₁ and stores the value in memory 49. The value of stored in
15 memory 49 is used to determine when the first TS packet 12 comprising application data of the next burst 23₂ will be received.

Likewise, the controller 47 may repeatedly extract a value of Δt_B from each FEC section 21 and update a value stored in memory 49. Preferably, the controller 47
20 extracts a value of Δt_B from the last FEC section 21_q (Figure 11) of an FEC burst 24₁ and stores the value in memory 49.

It will be appreciated that many modifications may be made to the embodiments hereinbefore described. For example, the mobile terminal may be a personal data
25 assistant (PDA) or other mobile terminal capable of at least of receiving signals via the first communications network 1. The mobile terminal may also be semi-fixed or semi-portable such as a terminal carried in vehicle, such as a car.

Claims

1. A method of transmitting bursts in a communications network, the method comprising:
 - 5 providing data for transmission;
 - providing forward error correction (FEC) data for said data;
 - forming a first set of bursts comprising transmission data; and
 - forming a second set of bursts comprising FEC data.

- 10 2. A method according to claim 1, comprising:
 - transmitting said first set of bursts via a first channel, and
 - transmitting said second set of bursts via a second, different channel.

3. A method according to claim 1 or 2, comprising:
 - 15 providing a first parameter for indicating a timing offset between a first, earlier burst comprising at least some of said transmission data and a second, later burst comprising further transmission data;
 - providing a second parameter for indicating a timing offset between a third, earlier burst comprising at least some of said FEC data and a fourth, later burst
 - 20 comprising further FEC data;
 - forming said first burst including said first timing parameter and
 - forming said third burst including said second timing parameter.

4. A method according to claim 3, wherein:
 - 25 said at least some of said transmission data comprises some of said transmission data; and
 - said further transmission data comprises some more of said transmission data.

- 30 5. A method according to claim 3, wherein:
 - said at least some of said transmission data comprises all of said transmission data; and

said further transmission data comprises additionally provided transmission data.

6. A method according to any one of claims 3 to 5, comprising:
5 said at least some of said FEC data comprises some of said FEC data; and
said further FEC data comprises some more of said FEC data.
7. A method according to any one of claims 3 to 5, comprising:
said at least some of said FEC data comprises all of said FEC data; and
10 said further FEC data comprises some additionally provided FEC data.
8. A method according to any one of claims 3 to 7, comprising:
dividing said first burst between a first set of packets;
identifying each of said first set of packets with a first identity;
15 dividing said third burst between a second set of packets; and
identifying each of said second set of packets with a second identity.
9. A method according to claim 8, wherein said first and second identities are
the same.
20
10. A method according to claim 8 or 9, comprising:
dividing said second burst between a third set of packets; wherein providing
said first timing parameter comprises:
specifying a time until a start of a first one of said third set of packets.
25
11. A method according to any one of claims 8 to 9, comprising:
dividing said fourth burst between a fourth set of packets; wherein providing
said second timing parameter comprises:
specifying a time until a start of a first one of said fourth set of packets.
30
12. A method according to any one of claim 8 to 11, comprising:
preparing service information; and
including said second identify in said service information.

13. A method according to claim 12, comprising:
including said second identity in a descriptor; and
including said descriptor in a table forming part of said service information.

5

14. A method according to any one of claims 3 to 13, wherein said transmission data comprises a plurality of data packets, and said method comprises:
placing at least some of data packets in respective ones of a first set of sections.

10

15. A method according to claim 14, comprising:
including said first timing parameter in at least one of said first set of sections.

15

16. A method according to claim 14 or 15, comprising:
calculating a timing parameter for each section based on said first timing parameter and
including a respective timing parameter in each of said first set of sections.

20

17. A method according to any one of claims 3 to 16, wherein said FEC data comprises a plurality of data packets, and said method comprises:
placing at least some of data packets in respective ones of a second set of sections.

25

18. A method according to claim 17, comprising:
including said second timing parameter in at least one of said second set of sections.

30

19. A method according to claim 17 or 18, comprising:
calculating a timing parameter for each section based on said second timing parameter and
including a respective timing parameter in each one of said second set of sections.

20. A method according to any preceding claim, comprising:
providing a first parameter for identifying a burst comprising at least some
of said transmission data;
- 5 providing a second parameter for identifying at least one burst comprising
FEC associated with said at least some of said transmission data;
forming a first burst including said first identifying parameter and
forming a second burst including said second identifying parameter.
- 10 22. A method according to any preceding claims, comprising:
labelling at least one burst of said first set of bursts with an identifier; and
labelling at least one burst of said second set of bursts with a corresponding
identifier.
- 15 23. A method of transmitting bursts in a communications network substantially
as herein before described with reference to Figures 1 to 23 of the accompanying
drawings.
24. A method of internet protocol datacasting over a digital broadcasting
20 network according to any preceding claim.
25. A computer program comprising computer program instructions for causing
data processing means to perform the method according to any preceding claim.
- 25 26. A system of transmitting bursts in a communications network comprising:
providing data for transmission;
providing forward error correction (FEC) data for said data;
forming a first set of bursts comprising transmission data; and
forming a second set of bursts comprising FEC data.
- 30 27. A network element comprising:
means for providing data for transmission;
means for providing forward error correction (FEC) data for said data;

means for forming a first set of bursts comprising transmission data; and
means for forming a second set of bursts comprising FEC data.

28. A multiprotocol encapsulator comprising:
5 an input for providing data for transmission;
a processor for providing forward error correction (FEC) data for said data;
a processor for forming a first set of bursts comprising transmission data
and
a processor for forming a second set of bursts comprising FEC data.
10
29. A terminal for receiving bursts from a communications network comprising:
means for receiving a first set of bursts comprising transmission data and
means for receiving a second set of bursts comprising forward error
correction (FEC) data for said transmission data.
15



INVEST FOR IN PEOPLE

Application No: GB 0322777.4
Claims searched: 1-29

Examiner: Adam Tucker
Date of search: 4 December 2003

Patents Act 1977 : Search Report under Section 17

Documents considered to be relevant:

| Category | Relevant to claims | Identity of document and passage or figure of particular relevance |
|----------|--------------------|--|
| X | 1-6, 14-19 & 24-29 | WO 00/70457 A1 (Onmipoint) See in particular page 3 lines 9-25, page 5 lines 11-14 and lines 25-26, page 12 line 25-page 13 line 16 and claims 1-4 |
| X | 1, 2 & 24-29 | EP 1306997 A1 (Fujitsu) See in particular paras 19 & 23 |
| X | 1, 20, 22, 24-29 | US 20020054608 A1 (Wan et al.) See in particular paras 21-32, 137-138, 146 & 148 |
| A | - | EP 1071221 A1 (Matsushita) See in particular claims 1-12 |

Categories:

| | |
|--|---|
| X Document indicating lack of novelty or inventive step | A Document indicating technological background and/or state of the art. |
| Y Document indicating lack of inventive step if combined with one or more other documents of same category | P Document published on or after the declared priority date but before the filing date of this invention |
| & Member of the same patent family | E Patent document published on or after, but with priority date earlier than, the filing date of this application |

Field of Search:

Search of GB, EP, WO & US patent documents classified in the following areas of the UKC^v:

H4P, H4L

Worldwide search of patent documents classified in the following areas of the IPC⁷

H03M, H04B, H04H, H04N

The following online and other databases have been used in the preparation of this search report:

WPI, EPODOC, PAJ, INSPEC