

(12) UK Patent

(19) GB

(11) 2567151

(13) B

(45) Date of B Publication

24.06.2020

(54) Title of the Invention: Cellular telecommunications network

(51) INT CL: *H04W 36/24* (2009.01) *H04W 24/10* (2009.01) *H04W 36/00* (2009.01) *H04W 64/00* (2009.01)

(21) Application No: 1715869.2

(22) Date of Filing: 29.09.2017

(43) Date of A Publication 10.04.2019

(72) Inventor(s):

**Farhad Mehran
Richard Mackenzie**

(73) Proprietor(s):

**British Telecommunications public limited company
81 Newgate Street, London, EC1A 7AJ,
United Kingdom**

(56) Documents Cited:

US 9392533 B1 **US 20160247330 A1**
US 20140066092 A1 **US 20120127876 A1**
US 20120039365 A1

(74) Agent and/or Address for Service:

**BT Group Legal
Intellectual Property Department, Ground Floor,
Faraday Building, 1 Knightrider Street, LONDON,
EC4V 5BT, United Kingdom**

(58) Field of Search:

As for published application 2567151 A viz:
INT CL **H04W**
Other: **EPODOC, WPI, Patent Fulltext, XP3GPP**
updated as appropriate

Additional Fields

Other: **None**

GB 2567151 B

Fig. 1

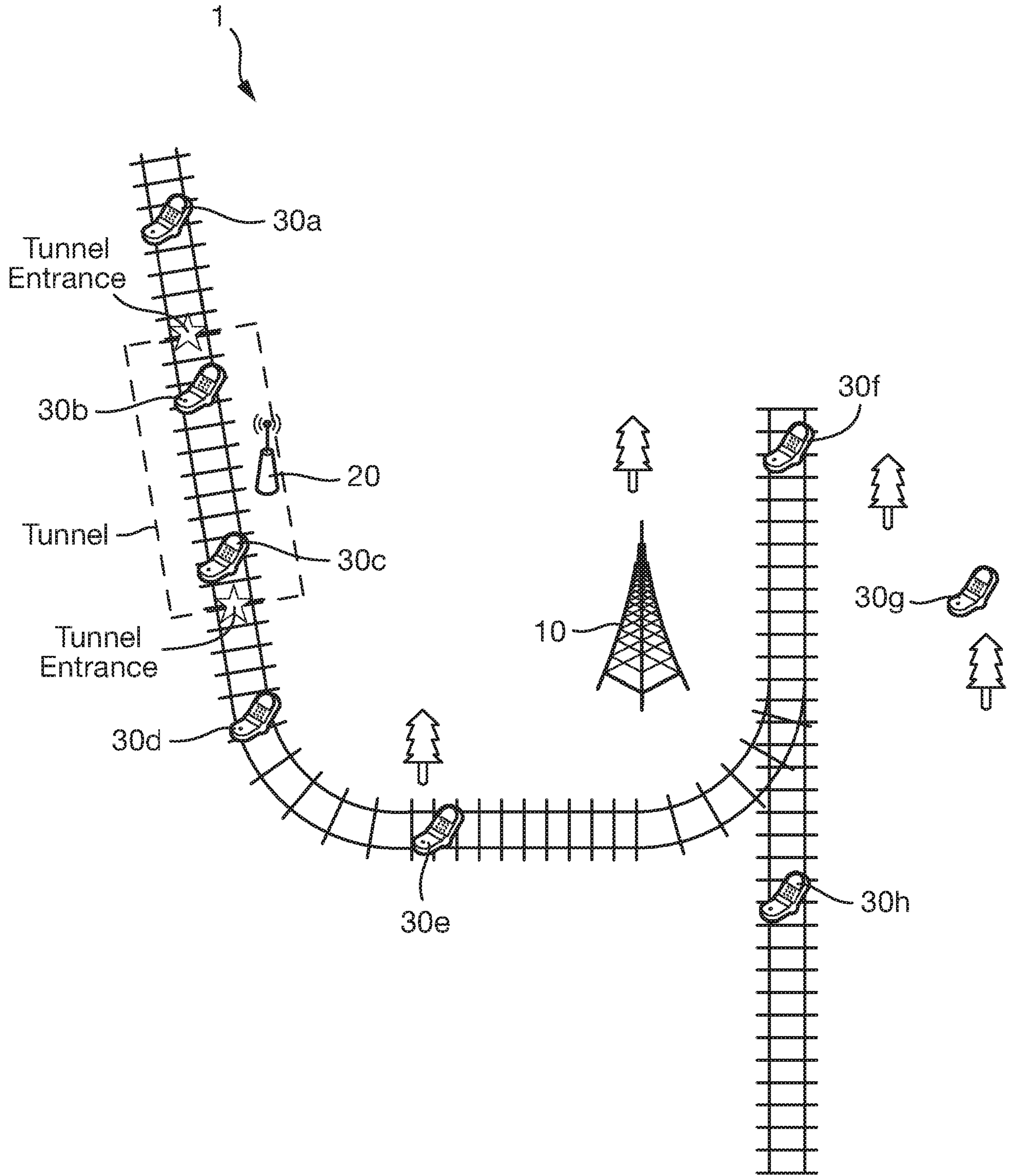

15 11 17

Fig. 2

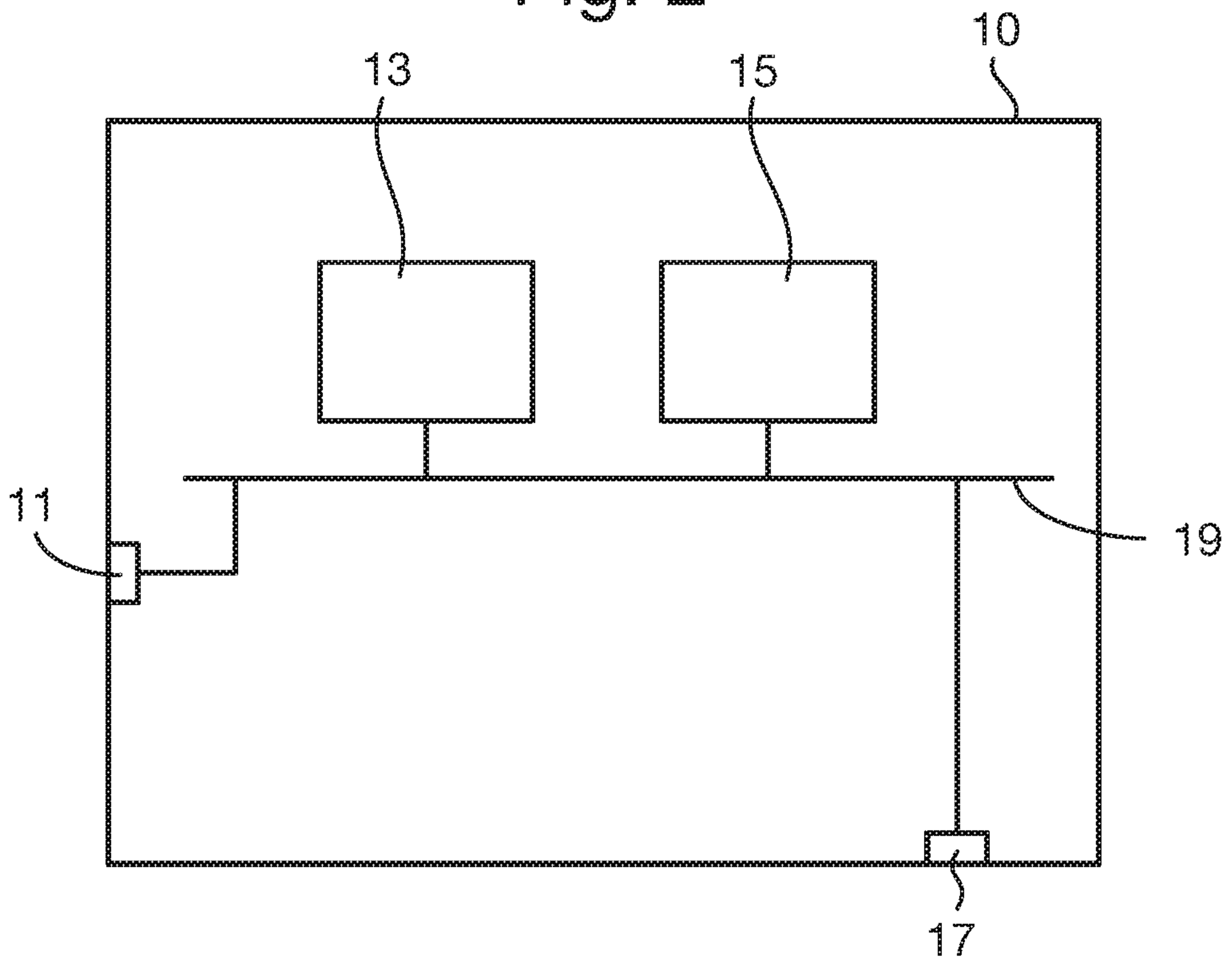

Fig. 3

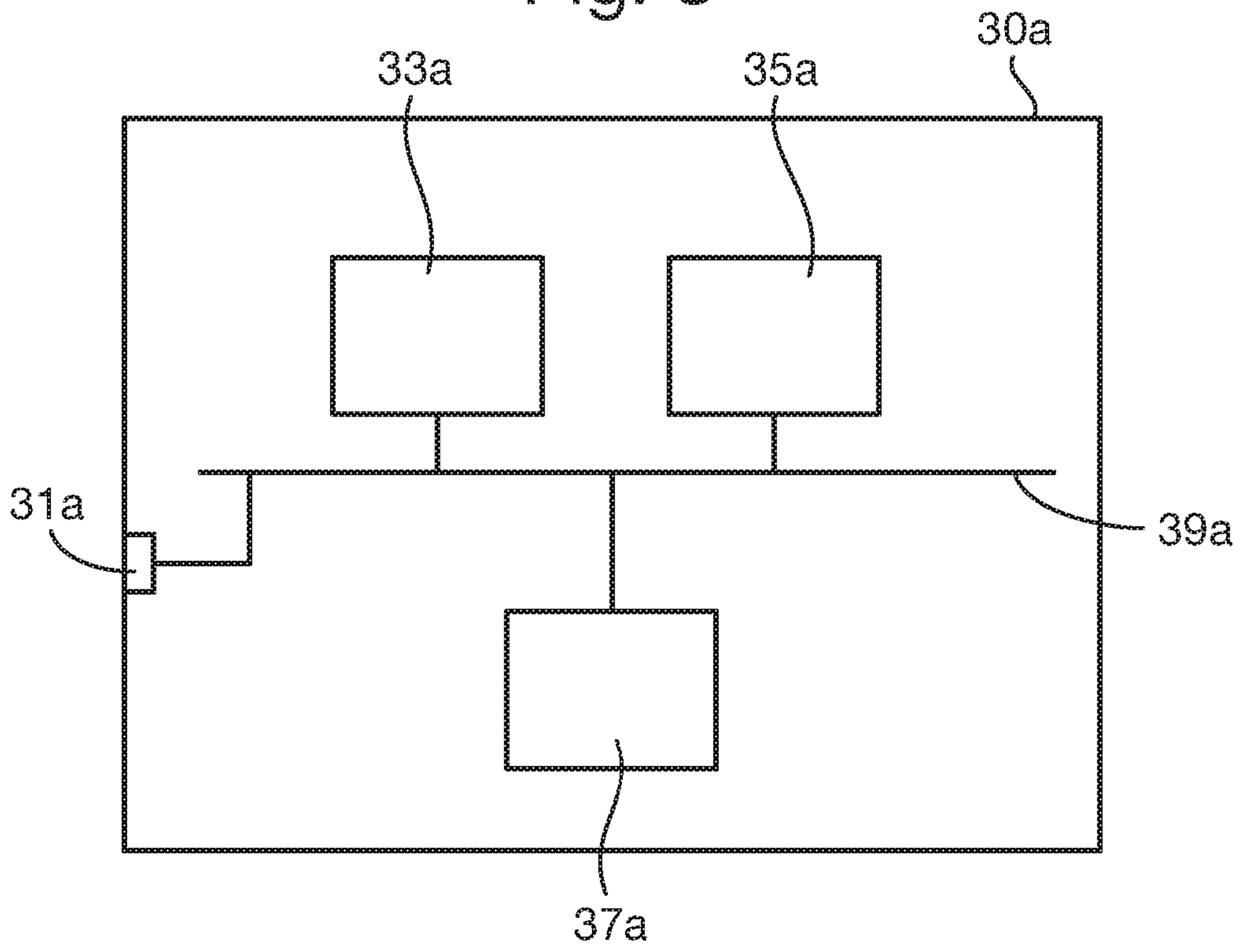
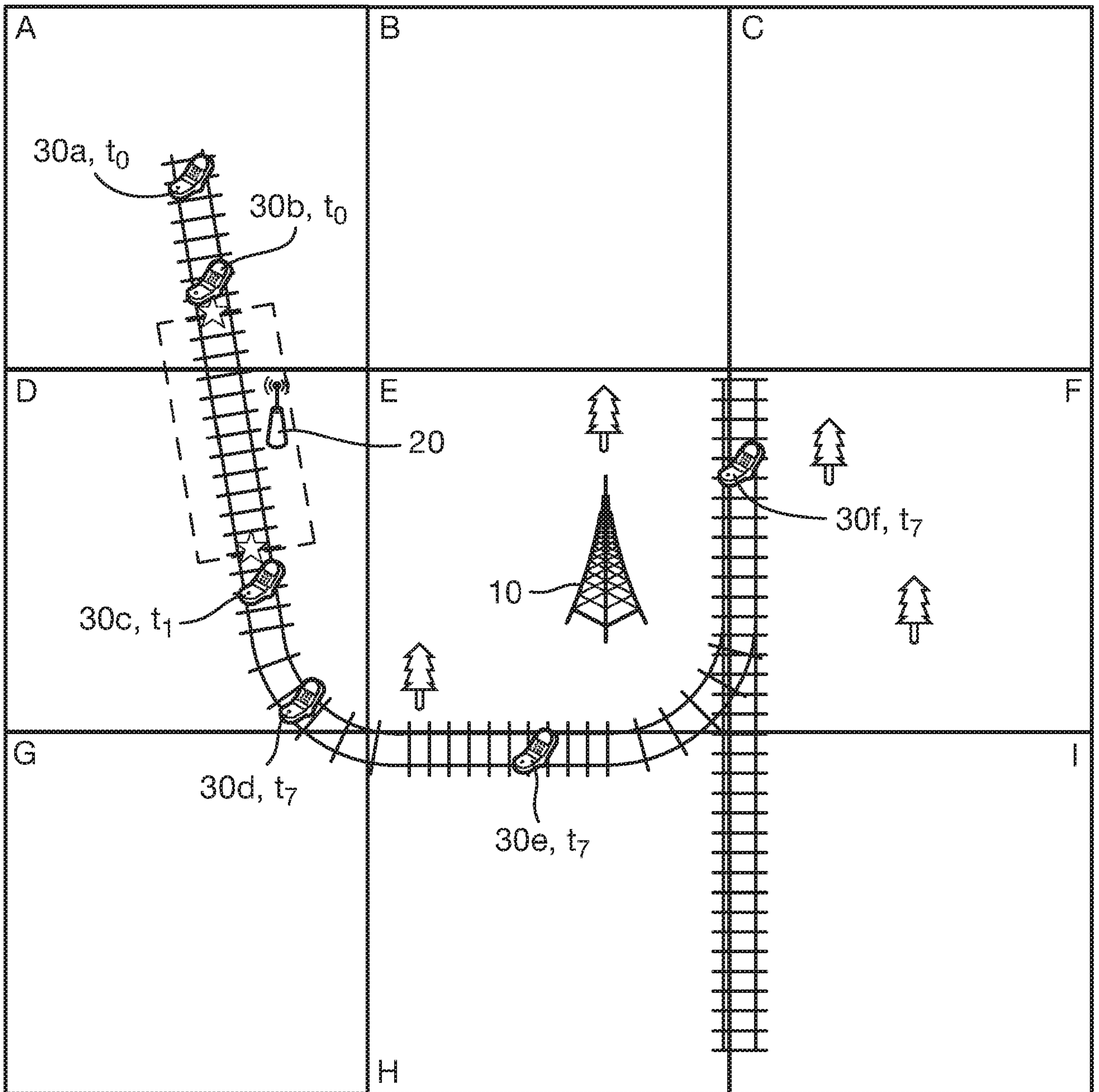
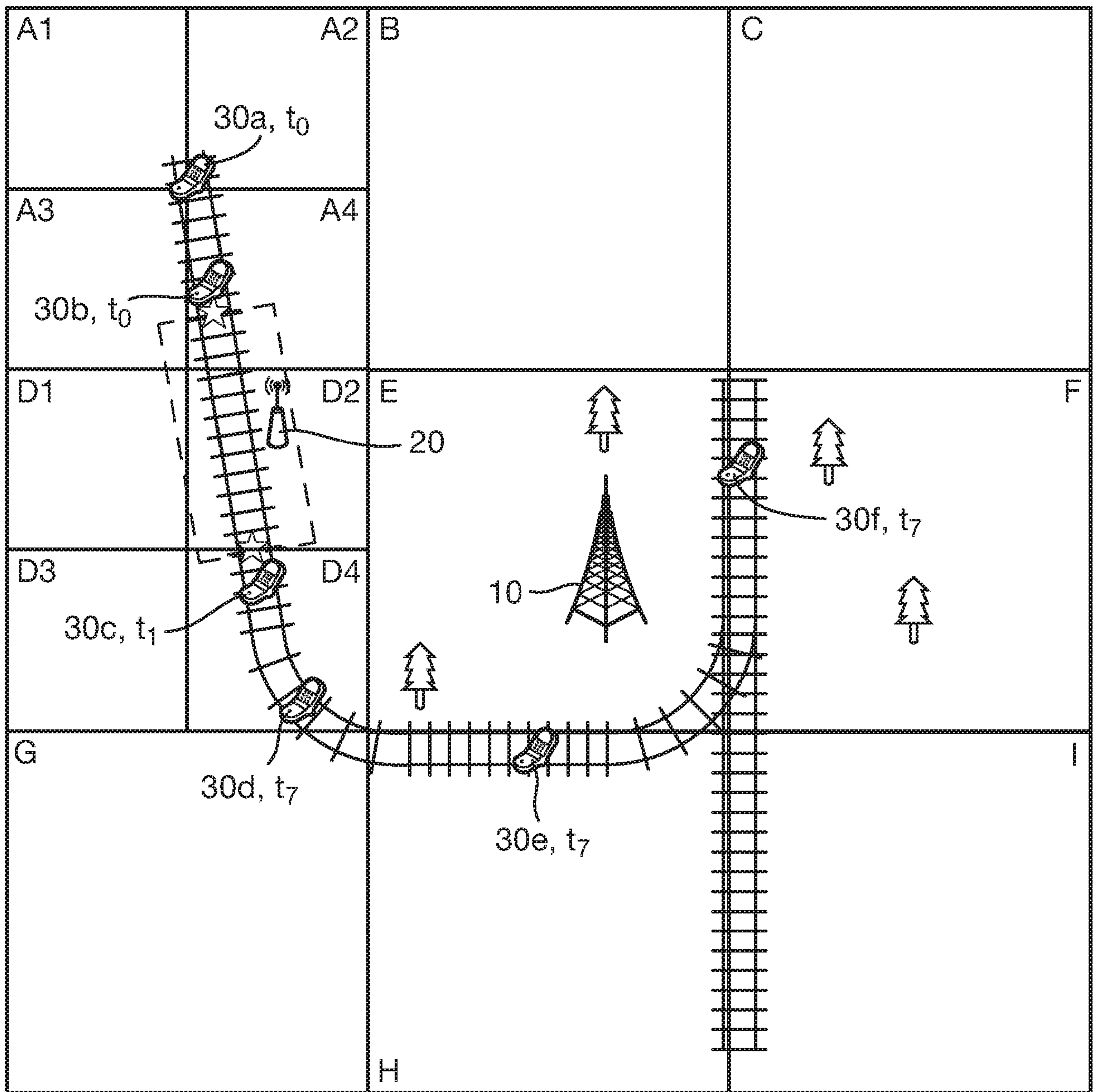

Fig. 4



15 11 17

Fig. 5



15 11 17

Fig. 6

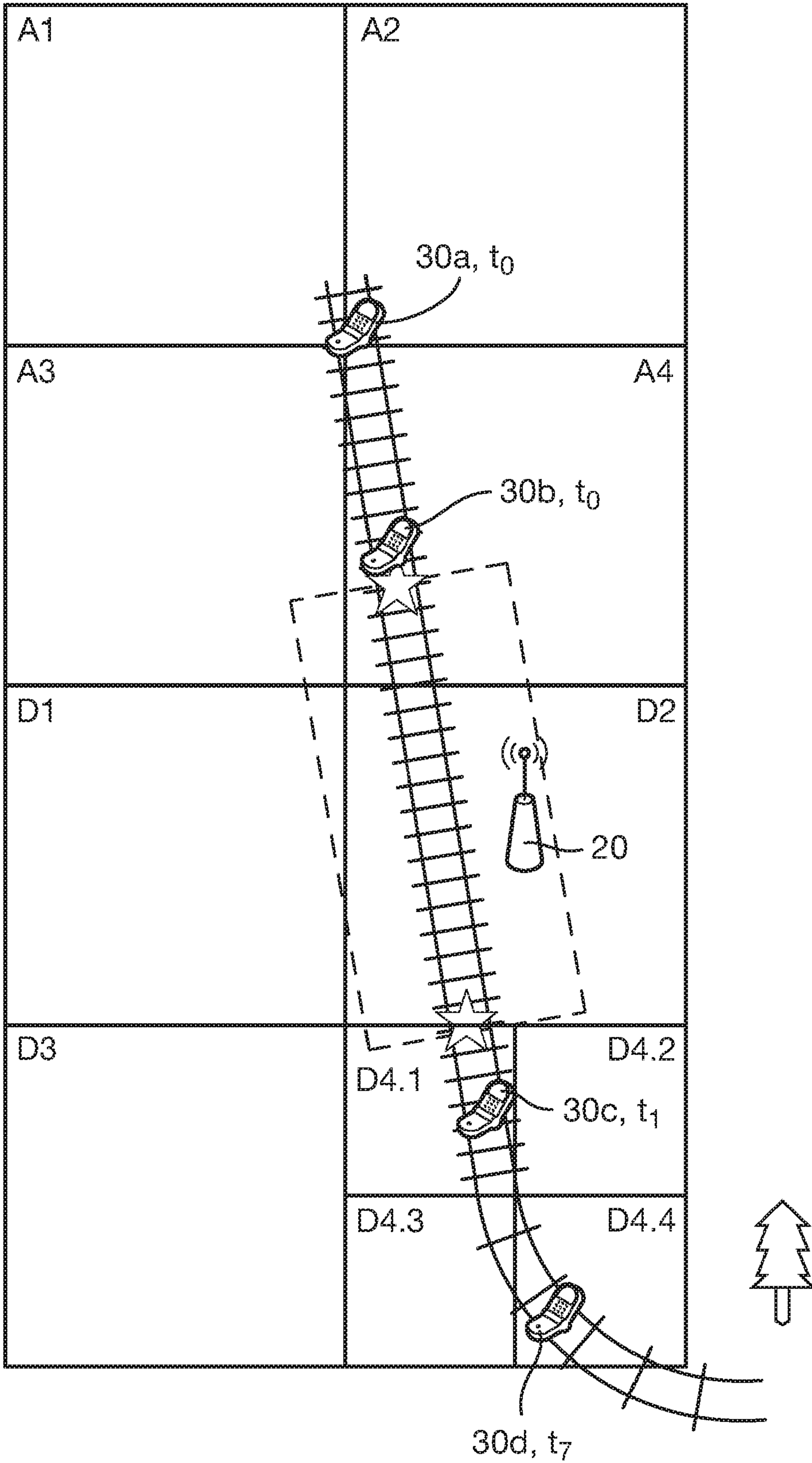

15 11 17

Fig. 7

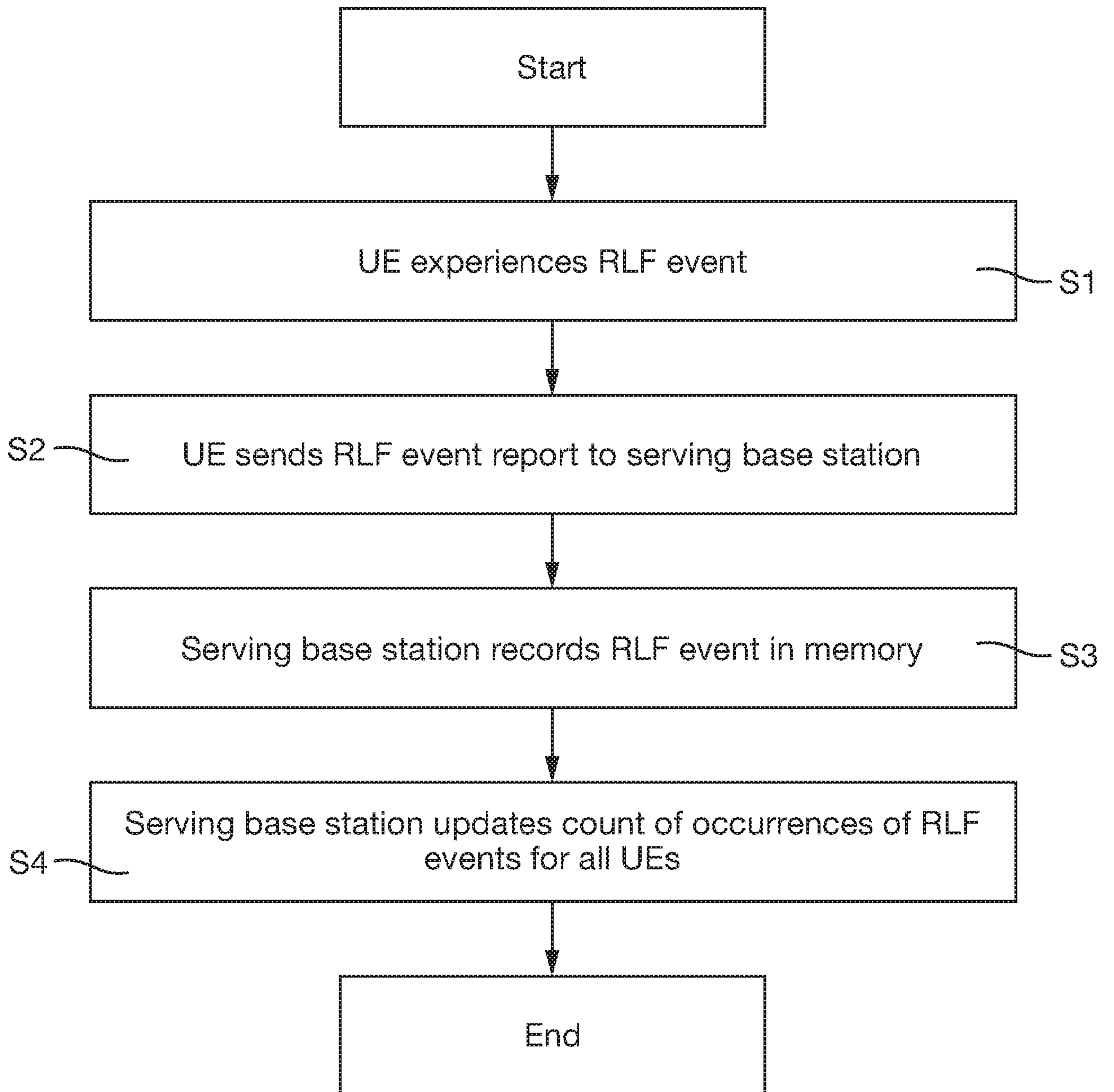

15 11 17

Fig. 8

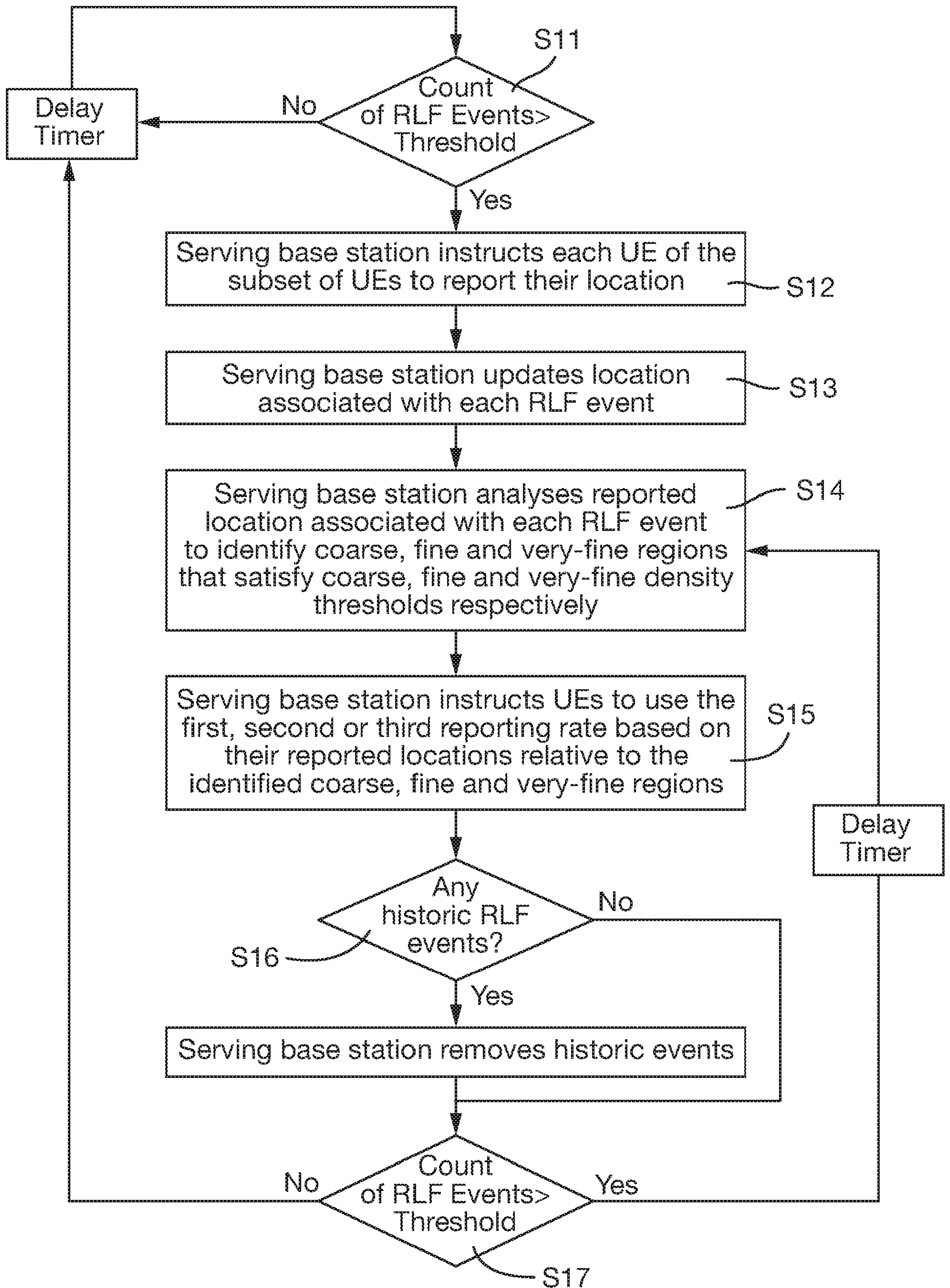
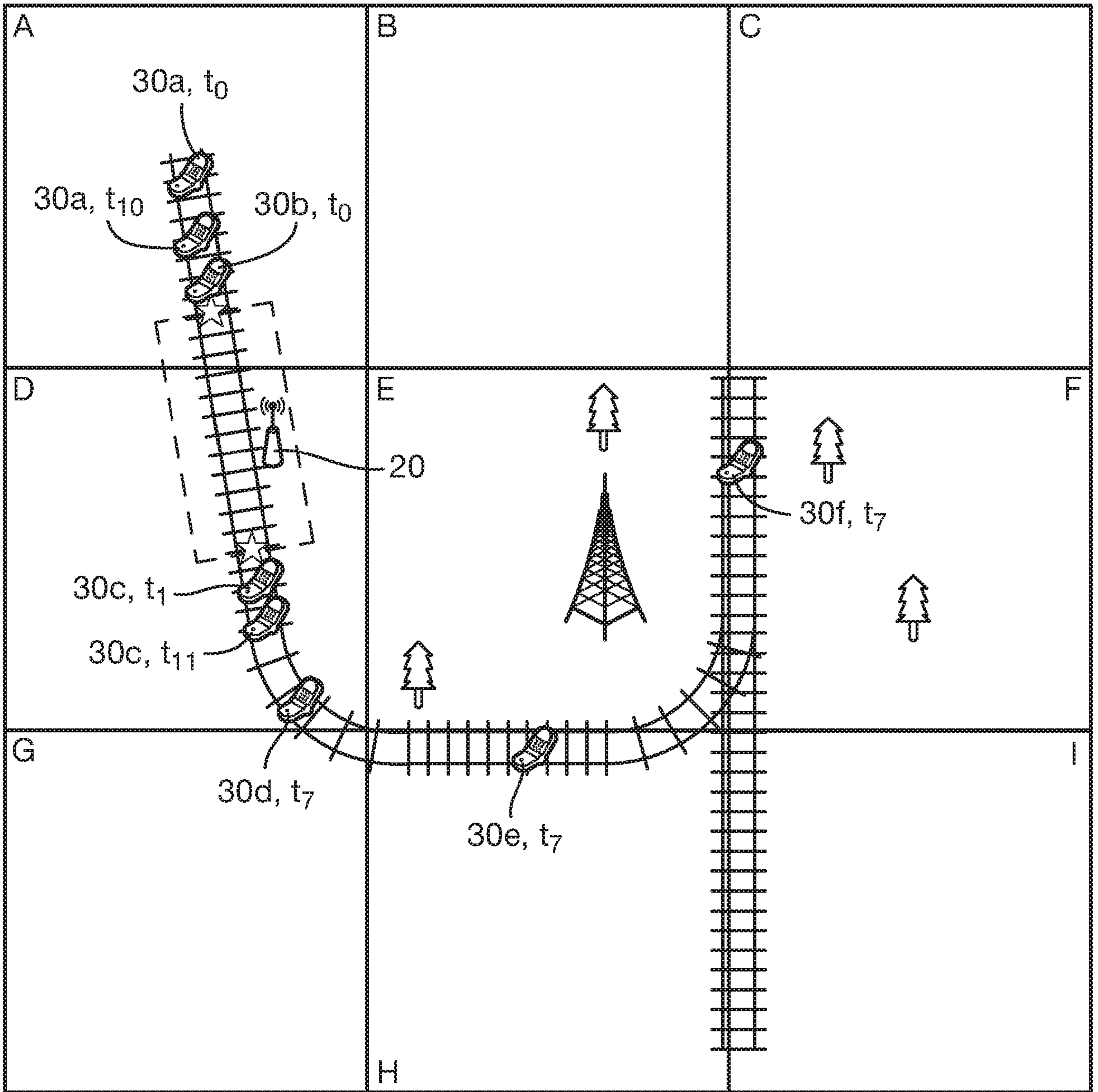
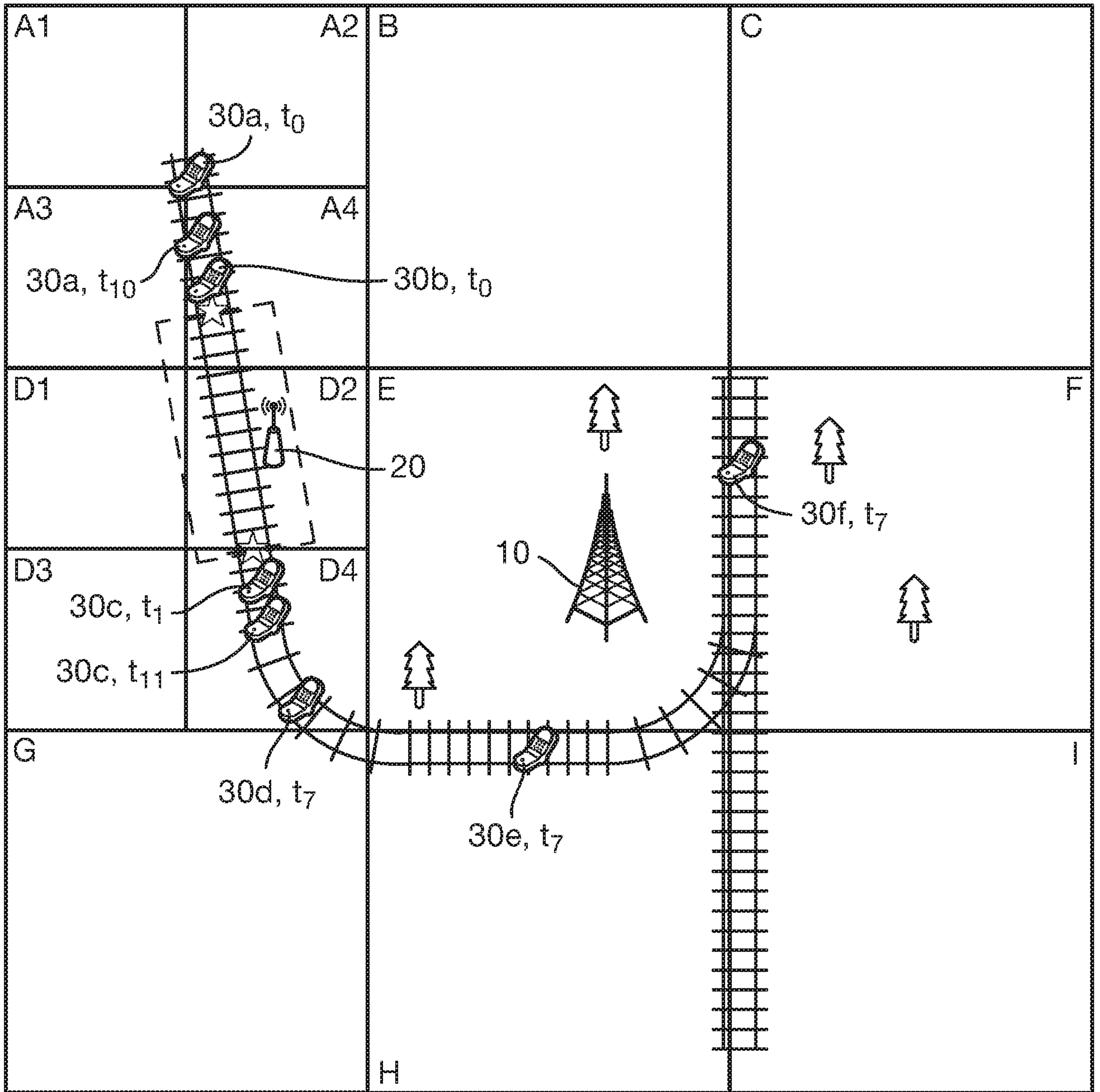

Fig. 9



15 11 17

Fig. 10



15 11 17

Fig. 11

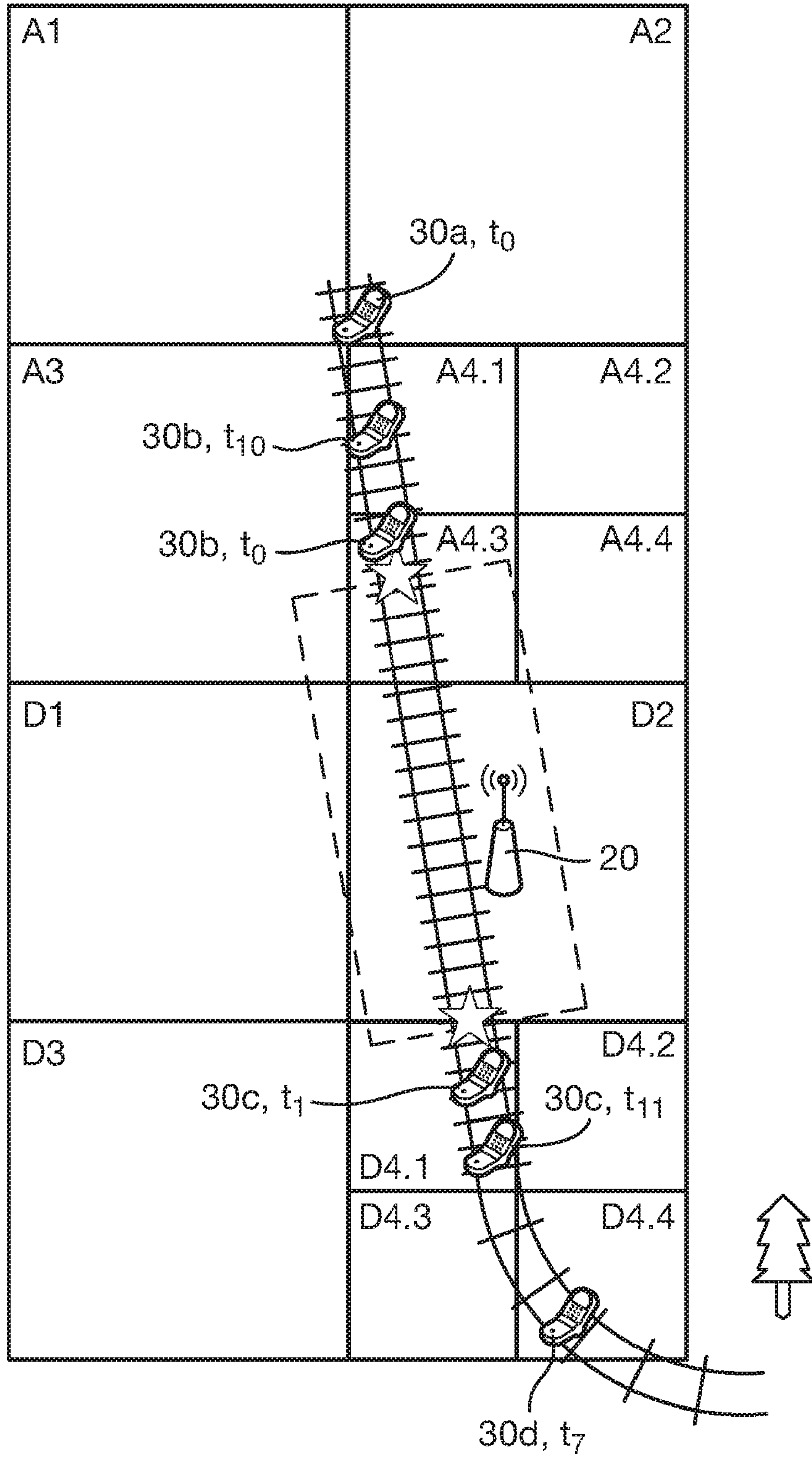

15 11 17

Fig. 12

15 11 17

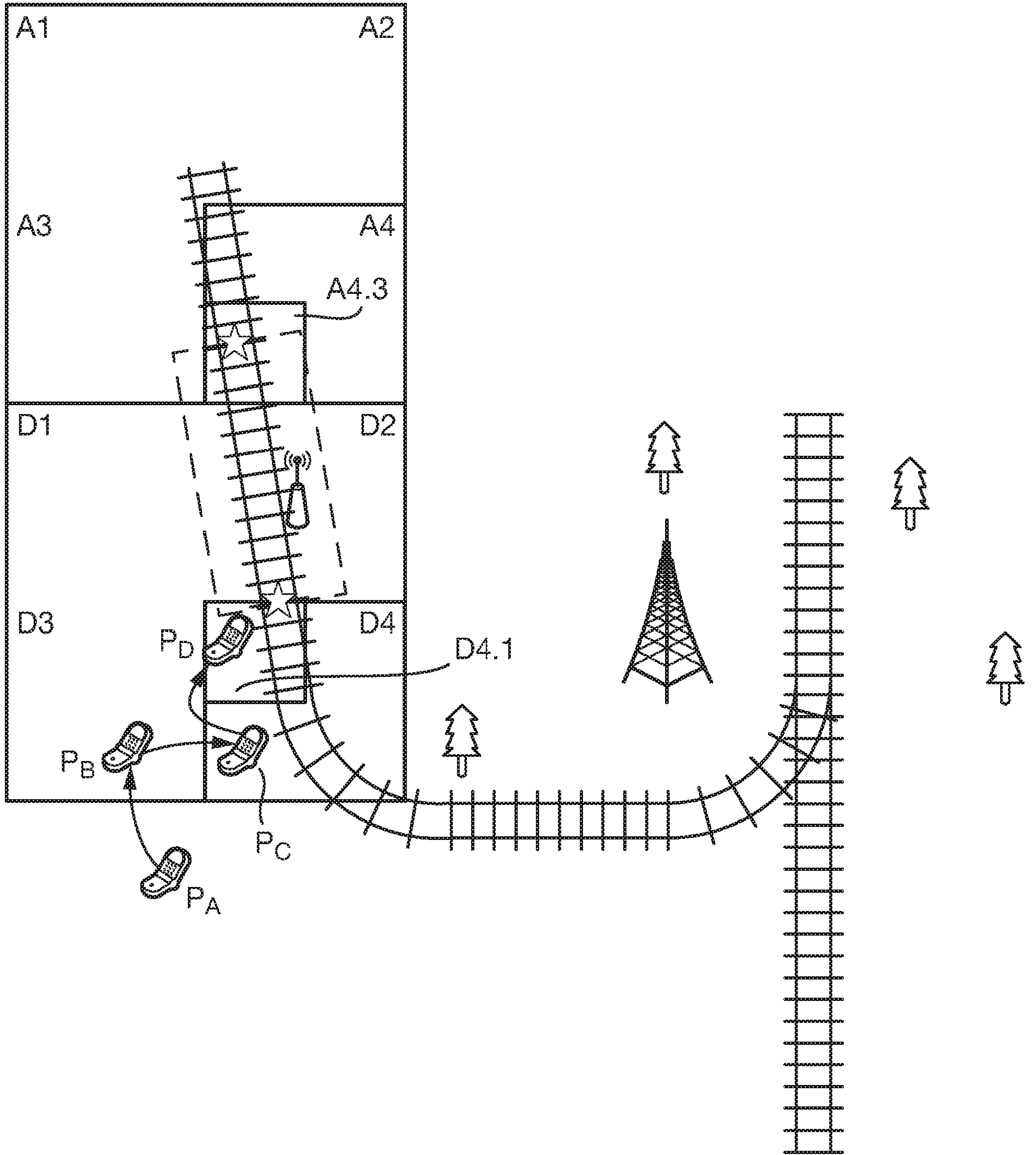
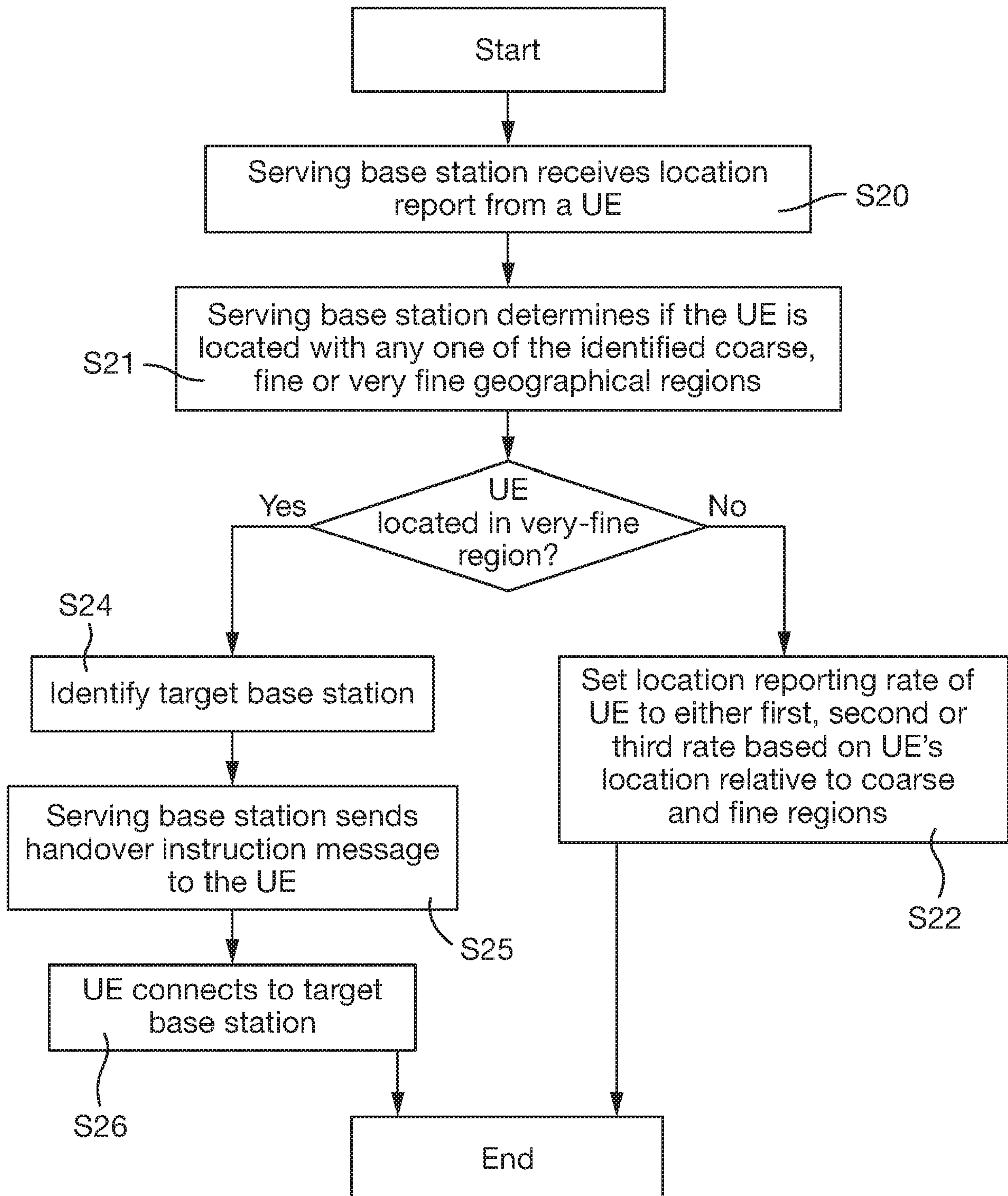

Fig. 13



CELLULAR TELECOMMUNICATIONS NETWORK

Field of the Invention

The present invention relates to a cellular telecommunications network.

5

Background

A cellular telecommunications network includes a plurality of base stations which each transmit wireless signals about a coverage area (typically called a “cell”) to one or more User Equipment (UE). The base stations are also connected to a core network to interconnect the UE with the Internet and core network nodes (such as the Operations Support System (OSS)). In conventional cellular networks, this “backhaul” connection between the base station and the core network is typically via an Ethernet or optical fibre link, but in modern cellular networks this may be in part via a Digital Subscriber Line (DSL) connection (for example, if the base station is a “Home evolved Node B” (HeNB), also known as a small cell).

15

As each base station has a limited coverage area and UEs are normally mobile, cellular networking protocols have a defined process for UEs to disconnect from one base station and connect to another base station with seamless connectivity. This process is known as a “handover”. A general overview of the handover process will now be described, which is divided into three phases – preparation, execution and completion. The UE is connected to a first base station of a plurality of base stations. The first base station is therefore the UE’s “serving” base station, and the UE is configured to perform measurements of various parameters of its serving base station and of other base stations of the plurality of base stations. In the preparation phase, the serving base station provides one or more thresholds to the UE for the measurements. If the UE’s measurements satisfy one or more of these thresholds, then a measurement report is sent from the UE to the serving base station, which triggers the handover of the UE to another base station. The serving base station determines which other base station should become the next serving base station for the UE based on the UE’s measurement report. The serving base station and this target base station agree for the handover to take place. In the next phase, execution, the serving base station informs the UE that it should handover to the target base station. The UE will then connect to the target base station. In the completion phase, all routing of packets for the UE is changed to the target base station. The handover is then complete.

20

25

30

35

In certain scenarios, it is appropriate for the handover to be performed without the first step (preparation). This is often known as a “blind handover”, in which the serving base station will instruct the UE to connect to a target base station without it being triggered by a UE measurement report satisfying a precondition. There is a greater chance that the blind handover is unsuccessful or the connection between the UE and the target base station won't adequately serve the UE's requirements when compared to a handover including the preparation phase. However, it may be more appropriate to perform a blind handover in scenarios where the UE's connection to its serving base station may rapidly deteriorate such that a full handover (including the preparation phase) may not have time to complete, such as when the UE enters a tunnel and there is a sudden decrease in signal strength between the UE and the serving base station.

A trigger for a blind handover may be based on the UE's location. For example, if it is determined that a UE is approaching a particular location where there is a sudden decrease in signal strength (e.g. the location of a tunnel entrance), then this may be used as a trigger for a blind handover in which the preparation phase is omitted and the serving base station instructs the UE to connect to the target base station (e.g. one positioned inside the tunnel). To perform blind handovers based on the location of the UE, then the location of the UE has to be determined. There are several techniques for determining the location of the UE. The most well-known is by using Global Navigation Satellite Systems (GNSS), such as the Global Positioning System (GPS). These produce very accurate estimates of the UE's location, but require greater UE radio and/or processing resources than other techniques as the UE performs both the measurements and the estimation of its position based on those measurements. Other techniques, such as Observed Time Difference of Arrival (OTDOA) and Enhanced Cell Identifier (E-CID), as defined in the 3rd Generation Partnership Project (3GPP) Long Term Evolution (LTE) protocol (Release-9), require fewer UE radio/processing resources as the estimation of the UE's position may be performed by a Location Service Client (LCS) Server (LS). However, these techniques still require some UE radio/processing resources in order to perform the required measurements.

Summary of the Invention

According to a first aspect of the invention, there is provided a method in a cellular telecommunications network, the cellular telecommunications network including a base

station having a coverage area, and further including a plurality of User Equipment, UE, located within the base station's coverage area, the method comprising the steps of: instructing a first plurality of UEs to report their location; associating an occurrence of a connection performance indication for each UE of the first plurality of UEs with a reported location for that UE; defining a first geographical region in which the density of reported locations associated with occurrences of connection performance indications is above a first density threshold; defining a second geographical region in which the density of reported locations associated with occurrences of connection performance indications is above a second density threshold, wherein the area of the first geographical region is greater than the area of the second geographical region; instructing a second plurality of UEs within the first geographical region to report their location at a first reporting rate; and instructing a third plurality of UEs within the second geographical region to report their location at a second reporting rate.

The method may further comprise the step of determining that a count of occurrences of connection performance indications for one or more UEs of the plurality of UEs satisfies a threshold.

The connection performance indication may be a Radio Link Failure, RLF.

The method may be performed by a first base station. Alternatively, the method may be performed by a network node, wherein the network node is in communication with one or more base stations.

According to a second aspect of the invention, there is provided a computer program comprising instructions which, when the program is executed by a computer, cause the computer to carry out the method of the first aspect of the invention. The computer program may be stored on a computer-readable medium.

According to a third aspect of the invention, there is provided a network node for a cellular telecommunications network, the network including a plurality of User Equipment, UE, the network node comprising: a transceiver configured to receive data from the plurality of UEs; memory configured to store said data; and a processor configured to perform the steps of the first aspect of the invention. The network node may be a base station.

Brief Description of the Figures

In order that the present invention may be better understood, embodiments thereof will now be described, by way of example only, with reference to the accompanying drawings in which:

5

Figure 1 is a schematic diagram of an embodiment of a cellular telecommunications network of the present invention;

Figure 2 is a schematic diagram of a base station of the network of Figure 1;

Figure 3 is a schematic diagram of a User Equipment of the network of Figure 1;

10

Figure 4 is a schematic diagram of the network of Figure 1, showing locations of RLF events overlaid onto a first grid;

Figure 5 is a schematic diagram of the network of Figure 1, showing locations of RLF events overlaid onto a first and second grid;

Figure 6 is a schematic diagram of the network of Figure 1, showing locations of RLF events overlaid onto a first, second and third grid;

15

Figure 7 is a flow diagram of a first process of a first embodiment of a method of the present invention;

Figure 8 is a flow diagram of a second process of the method of Figure 7;

Figure 9 is a schematic diagram of the network of Figure 1, showing locations of RLF events overlaid onto the first grid;

20

Figure 10 is a schematic diagram of the network of Figure 1, showing locations of RLF events overlaid onto the first and second grids;

Figure 11 is a schematic diagram of the network of Figure 1, showing locations of RLF events overlaid onto the first, second and third grid; and

25

Figure 12 is a schematic diagram of the network of Figure 1, illustrating the movement of a User Equipment.

30

Detailed Description of Embodiments

A first embodiment of a cellular telecommunications network 1 will now be described with reference to Figures 1 to 6. Figure 1 is an overhead map of an area having a first and second base station 10, 20 and a plurality of User Equipment (UE) 30a...30h, several of which are travelling along a train line which passes through a tunnel. The first base station 10 is a macro base station having a relatively large coverage area compared to

35

the second base station 20, which is a femto base station having a coverage area that includes the inside of the tunnel only.

A schematic diagram of the first base station 10 is illustrated in Figure 2. The first base station 10 includes a first transceiver 11, a processor 13, memory 15 and a second transceiver 17, all connected via bus 19. The first transceiver 11 is an antenna configured for communication with any one of the plurality of User Equipment (UE) via the Long Term Evolution (LTE) protocol. The second transceiver 17 is an optical fibre connection, which is used for communicating with one or more cellular core networking entities via the core connection and/or for communicating with one or more neighbouring base stations (e.g. using an X2 message). The second base station 20 is of similar construction, but its components may be of a different form to be more suitable for short range communications (for example, a low-power antenna).

A schematic diagram of a first UE 30a of the plurality of UEs is shown in Figure 3. The first UE 30a includes a first transceiver 31a, a processor 33a, memory 35a, display 37a (including a user interface), and Global Positioning System (GPS) receiver 38a, all connected via bus 39a. The first transceiver 31a is an antenna configured for communication with the first and/or second base station via the LTE protocol. In this embodiment, the UE is configured to measure its radio environment (using the antenna 31a and processor 33a) to determine the quality of the connection between the UE and one or both of the first and second base stations 10, 20. In particular, if the quality of the connection between the UE and its serving base station (that is, the base station which it is connected to) drops below an operator defined threshold, then an occurrence of a Radio Link Failure (RLF) is recorded (in memory 35a) and reported. Furthermore, the first UE 30a includes a GPS function, which is implemented by processor 33a and GPS receiver 38a, which allows the first UE 30a to determine its location. The other UEs of the plurality of UEs are of the same or similar form to the first UE 30a.

A first embodiment of a method of the present invention will now be described. In an initial arrangement of this example as shown in Figure 1, all UEs of the plurality of UEs 30a...30h are served by the first base station 10. All UEs of the plurality of UEs 30a...30h are configured to determine their location (using a GPS function implemented by processor 33a and GPS receiver 38a) and report the determined location (together with a timestamp indicating the actual time the location was determined) to the first base

station 10 at a first reporting rate. In this example, the first reporting rate is one location report every 10 minutes. The first base station 10 receives this report and stores the information (a UE identifier (e.g. International Mobile Subscriber Identifier (IMSI) or International Mobile Equipment Identifier (IMEI)), the UE's location (in GPS coordinates), and a timestamp associated with the UE's location) in memory 15.

Thus, each UE connected to the first base station 10 is configured to periodically report its location to the first base station 10, such that any new UE connecting to the first base station 10 is also configured in the same manner. It will be shown later in this description that the location reporting rate may be varied, but any UE will still report its location at at least the first reporting rate.

A subset of the plurality of UEs (30a, 30b, 30c, 30d, 30e, 30f) are on a train which passes through the tunnel, whilst the other UEs (30g, 30h) do not pass through the tunnel. Each UE of the subset of UEs 30a...30f experiences a loss of service from the first base station 10 when it is located within the tunnel. Furthermore, in this example, the tunnel opening is so narrow, and the surrounding material so dense, that the first base station's signals attenuate rapidly at the tunnel entrances. These properties mean that a traditional handover (including the preparation phase) cannot be triggered and successfully completed before each UE enters the tunnel via either tunnel entrance and can no longer communicate with the first base station 10. Accordingly, each UE will record an RLF event in memory, which will be reported to the first base station 10 when it re-emerges from the tunnel and re-connects to the first base station 10.

The first base station 10 stores mapping data covering the area of Figure 1. As shown in Figure 4, the first base station 10 is configured to overlay a first grid onto this map, which defines nine coarse geographical regions (A to I). As shown in Figure 5, the first base station 10 is also configured to overlay a second grid onto this map (only a portion of the second grid is shown for simplicity), which defines 36 fine geographical regions, in which each coarse geographical region of Figure 4 is subdivided into four fine geographical regions (e.g. coarse geographical region A is subdivided into four fine geographical regions A1 to A4). As shown in Figure 6, the first base station 10 is also configured to overlay a third grid onto this map (only a portion of the map and a portion of the third grid is shown for simplicity), which defines 144 very-fine geographical regions, in which each fine geographical region is further subdivided into four very-fine

geographical regions (e.g. fine geographical region D4 is further subdivided into four very-fine geographical regions D4.1 to D4.4).

In a first step S1 of a first process of this first embodiment, as shown in Figure 7, the plurality of UEs are served by the first base station 10 and a subset of UEs 30a...30f pass through the tunnel (and therefore experience an RLF event). Once each UE of this subset of UEs re-emerges from the tunnel and reconnects to the first base station 10, they each report their RLF event to the first base station 10 (step S2). The RLF event report includes an identifier for the UE sending the RLF event report and a timestamp of the RLF event. In step S3, the first base station 10 stores the RLF event in memory 15 together with the associated UE identifier (e.g. IMSI) and the timestamp of the RLF event. This table is also used to store data on a location of the UE reporting the RLF event, which is initially populated with the previously reported location from the relevant UE (but may be updated following the remaining steps of this embodiment). An example data set is shown in the table below:

RLF Event ID	UE ID	Timestamp	Associated Location
RLF ₁	IMSI (UE 30a)	t ₁	GPS Coordinates (RLF ₁ , UE 30a, t ₀)
RLF ₂	IMSI (UE 30b)	t ₂	GPS Coordinates (RLF ₂ , UE 30b, t ₀)
...

It is noted that it is a prevailing condition in this embodiment that all UEs are configured to update their serving base station of any RLF event, such that any UE connected to the first base station 10 will report an RLF event occurring at any time to the first base station 10 and the first base station 10 will continue to record these RLF events in memory 15. The first base station 10 also maintains a count of occurrences of each reported RLF from any UE of the subset of UEs 30a...30f (step S4).

A second process will now be described with reference to Figure 8. In a first step S11, the first base station 10 determines if the count of occurrences of reported RLFs exceeds a threshold. If not, then the method loops back via a delay timer to check again at a subsequent time. In this example, the count of occurrences of reported RLFs exceeds the threshold and the method proceeds to step S12.

In step S12, the first base station 10 sends a first instruction message to each UE of the first subset of UEs 30a...30f to report their instantaneous location. Each UE of the first subset of UEs 30a...30f uses their GPS function to determine their location, and report their location to the first base station 10 (together with a timestamp indicating the time of the location determination).

In step S13, the first base station 10 then determines which UE location report includes a timestamp which is closest in time to that of the RLF event report's timestamp. That is, if the timestamp of the UE location report in step S12 (issued after the count of occurrences of RLFs exceeds a threshold) is closer to the RLF event's timestamp than the timestamp of the UE location report reported at the first reporting rate (prior to the count of occurrences of RLFs exceeding a threshold), then the timestamp of the UE location report of step S12 is used (and vice versa). The first base station 10 then updates the value in the "Associated Location" field for each RLF Event in memory 15:

RLF Event ID	UE ID	Timestamp	Associated Location
RLF ₁	IMSI (UE 30a)	t ₁	GPS Coordinates (RLF ₁ , UE 30a, t ₀)
RLF ₂	IMSI (UE 30b)	t ₂	GPS Coordinates (RLF ₂ , UE 30b, t ₀)
RLF ₃	IMSI (UE 30c)	t ₃	GPS Coordinates (RLF ₃ , UE 30c, t ₁)
RLF ₄	IMSI (UE 30d)	t ₄	GPS Coordinates (RLF ₄ , UE 30d, t ₇)
RLF ₅	IMSI (UE 30e)	t ₅	GPS Coordinates (RLF ₅ , UE 30e, t ₇)
RLF ₆	IMSI (UE 30f)	t ₆	GPS Coordinates (RLF ₆ , UE 30f, t ₇)

In step S14, the first base station 10 analyses the locations associated with each RLF event to determine if one or more of the coarse, fine and/or very-fine geographical regions of the first, second and third grids (as shown in Figures 4 to 6) meet or exceed a first, second and third density threshold respectively. This will now be explained in more detail for each of the first, second and third grids.

As shown in Figure 4, the first base station 10 is configured to plot the GPS coordinates associated with each RLF event over the first grid. It can therefore be determined how many UEs that reported an RLF event are associated with locations that are in each of the coarse geographical regions (A to I) of the first grid. The first base station 10 then determines whether any one of these coarse geographical regions meets or exceeds a

coarse density threshold, which is set to two RLF events per coarse geographical region. In this example, coarse geographical regions A and D satisfy this condition.

5 Turning to Figure 5, the first base station 10 is also configured to plot the GPS coordinates associated with each RLF event over the second grid in order to determine how many UEs that reported an RLF event are associated with locations that are in each of the fine geographical regions (A1 to A4, D1 to D4). It is only necessary to perform this on the fine geographical regions that are within the coarse geographical region(s) that satisfy the coarse density threshold. The first base station 10 then determines whether
10 any one of these fine geographical regions meets or exceeds a fine density threshold, which is set to two RLF events per fine geographical region. In this example, fine geographical region D4 satisfies this condition.

15 Turning to Figure 6, the first base station 10 is also configured to plot the GPS coordinates associated with each RLF event over the third grid in order to determine how many UEs that reported an RLF event are associated with locations that are in each of the very-fine geographical regions (D4.1 to D4.4). It is again only necessary to perform this on the very-fine geographical regions that are within the fine geographical region(s) that satisfy the fine density threshold. The first base station 10 then determines whether
20 any one of these very-fine geographical regions meets or exceeds a very-fine density threshold, which is set to two RLF events per very-fine geographical region. In this example, none of the very-fine geographical regions satisfies this condition.

25 Accordingly, following the first iteration of step S14, the first base station 10 determines that coarse geographical regions A and D meet the coarse density threshold, fine geographical region D4 meets the fine density threshold, and none of the very-fine geographical regions meet the very-fine density threshold.

30 In step S15, the first base station 10 sends an instruction message to each UE of the first subset of UEs 30a...30f, which instructs them to report their location to the first base station 10 at either the first, second or third reporting rate. The determination of whether a UE should report its location at the first, second, or third reporting rate is based on the following logic:

1. Is the UE's reported location associated with its last RLF event within a very-fine geographical region that satisfies the very-fine density threshold? If so, trigger a blind handover. If not,
2. Is the UE's reported location associated with its last RLF event within a fine geographical region that satisfies the fine density threshold? If so, use the third reporting rate. If not,
3. Is the UE's reported location associated with its last RLF event within a coarse geographical region that satisfies the coarse density threshold? Is so, use the second reporting rate. If not,
4. Use the first reporting rate.

In this embodiment, the first reporting rate is one location report every ten minutes, the second reporting rate is one location report every minute, and the third reporting rate is one location report every 10 seconds. Thus, following the first iteration of step S14, the reporting rate for the first and second UE 30a, 30b is set at the second reporting rate, the reporting rate for the third and fourth UEs 30c, 30d is set at the third reporting rate, and the reporting rate for the fifth and sixth UEs 30e, 30f continues at the first reporting rate. The seventh and eighth UEs 30g, 30h also continue to use the first reporting rate.

The first base station 10 maintains a table, in memory 15, of the reporting rate of all connected UEs, thus:

UE ID	Reporting Rate
30a	2 nd Reporting Rate
30b	2 nd Reporting Rate
30c	3 rd Reporting Rate
30d	3 rd Reporting Rate
30e	1 st Reporting Rate
...	...
30h	1 st Reporting Rate

The second process is then configured to loop back to either step S11 or step S14. The decision logic will be explained later in the description, but for now it is assumed the process loops back to step S14. As the process passes through a delay timer between iterations, the first base station 10 continues to receive RLF event reports from any UE that has experienced an RLF event, and further receives the location of UEs 30a... 30h

at the first, second, or third reporting rate. The first base station 10 may then associate a location report with an RLF report for a particular UE based on their respective timestamps such that the location report which was determined in the smallest time interval (before or after) the RLF event is used as the “associated location” of the RLF event. It is noted that a UE of the plurality of UEs but not of the first subset of UEs, (i.e. it did not report an RLF event prior to the first iteration of the second process), or any new UE which has subsequently connected to the first base station 10, may now have reported an RLF event, in which case that RLF event will also be considered in the identification of the coarse, fine and very-fine regions in the second iteration of the second process. Furthermore, any UE location report (at the first, second or third reporting rate) indicating that it has moved to a region of different size (e.g. coarse to fine, or fine to coarse) will cause the UE to change its location reporting rate to that associated with its new region. In this example, the data set stored in memory 15 at the first base station 10 after the delay timer has elapsed is:

RLF Event ID	UE ID	Timestamp	Associated Location
RLF ₁	IMSI (UE 30a)	t ₁	GPS Coordinates (RLF ₁ , UE 30a, t ₀)
RLF ₂	IMSI (UE 30b)	t ₂	GPS Coordinates (RLF ₂ , UE 30b, t ₀)
RLF ₃	IMSI (UE 30c)	t ₃	GPS Coordinates (RLF ₃ , UE 30c, t ₁)
RLF ₄	IMSI (UE 30d)	t ₄	GPS Coordinates (RLF ₄ , UE 30d, t ₇)
RLF ₅	IMSI (UE 30e)	t ₅	GPS Coordinates (RLF ₅ , UE 30e, t ₇)
RLF ₆	IMSI (UE 30f)	t ₆	GPS Coordinates (RLF ₆ , UE 30f, t ₇)
RLF ₇	IMSI (UE 30a)	t ₈	GPS Coordinates (RLF ₇ , UE 30a, t ₁₀)
RLF ₈	IMSI (UE 30c)	t ₉	GPS Coordinates (RLF ₈ , UE 30c, t ₁₁)
...

On the second iteration of step S14, the first base station 10 again plots the GPS coordinates associated with each RLF event on the first, second and third grids. These are shown in Figures 9, 10 and 11 respectively. As shown in Figure 9, coarse geographical regions A and D again satisfy the coarse density threshold; as shown in Figure 10, fine geographical regions A4 and D4 satisfy the fine density threshold; and as shown in Figure 11, very-fine geographical region D4.1 satisfies the very-fine density threshold.

In the second iteration of step S15, the first base station 10 sends an instruction message to the first, second, third, and fourth UEs to update their location reporting rates using the logic set out above (in the first iteration of step S15). The logic sets the reporting rate based on the reported location associated with the UE's last RLF event. For example, UE 30a has reported two RLF events (RLF₁, RLF₇) at time t₁ and time t₈ (t₈ occurring after t₁), so the first base station 10 determines the reporting rate for UE 30a based on its reported location (GPS Coordinates (RLF₇, UE 30a, t₁₀)) associated with RLF₇.

The first base station 10 also updates its location reporting rate table, thus:

UE ID	Reporting Rate
30a	3 rd Reporting Rate
30b	3 rd Reporting Rate
30c	3 rd Reporting Rate
30d	3 rd Reporting Rate
30e	1 st Reporting Rate
...	...
30h	1 st Reporting Rate

It can be seen that the method of this embodiment increases the reporting rate of a UE if it is associated with a geographical region with a greater density of RLF events. In doing so, it is more likely an RLF event report from a UE in that geographical region will report its location within a shorter timescale of the RLF event (as the reporting rate is greater) and is therefore more accurate. By performing this method across many UEs, it is possible to identify successively narrower geographical regions around the location of the cause of an RLF event (e.g. a tunnel), in which the location reporting rate of the UEs increases as they move into narrower regions. It is also noted that this method strikes a balance between the urgency of collecting location data for each UE (in order to accurately plot the location of an RLF event) with the power consumption required for UEs to frequently report their locations (due to the use of processing and radio resources).

Following each iteration of the second process, the method loops back to either step S11 or S14. This will now be explained in more detail. Once the first base station 10 has set the location reporting frequency for each UE, it is determined in step S16 whether any

data is now too old to be relevant. That is, each data tuple in the RLF event table above is associated with a time period (e.g. one hour), after which the RLF event is considered historic. In this example, RLF events RLF₁, RLF₂ and RLF₃ are considered historic, whereas RLF events RLF₃ to RLF₈ are still valid.

5

In the next step, S17, the first base station 10 determines if the count of occurrences of RLF events (excluding historic events) is still greater than the threshold (used in step S11). If so, then the method loops back to step S14 for a further iteration. It is noted that this further iteration no longer considers the historic RLF events, which may change the determination of whether each of the coarse, fine and very-fine geographical regions satisfies the relevant thresholds. Thus, the reporting rates of each UE may dynamically increase or decrease following each iteration.

10

If step S17 results in a negative determination such that the count of occurrences of RLF events is now less than the threshold, then the method loops back to step S11 in which the first base station 10 periodically checks whether a subsequent count of RLF events exceeds a threshold. It is noted that upon a new positive determination that the count of RLF events exceeds a threshold, the first base station 10 then requests the instantaneous location of all UEs that have reported an RLF event.

15

20

In the above embodiment, each UE includes a GPS function in order to estimate their location and provide a location report to the serving base station. However, the skilled person will understand that this is non-essential, and other forms of positioning schemes, such as OTDOA may be used. Furthermore, the UEs are configured to measure their radio environment to determine if they are experiencing an RLF event, and record and report such an occurrence. However, again, this is non-essential. Any other form of measurement of the connection performance which would deteriorate at locations where a blind handover should be performed would be suitable.

25

30

In the second process of the above embodiment, the UEs emerge from the tunnel and reconnect to the first base station, such that the first base station then receives the RLF event report. However, this is non-essential. That is, following an RLF event, each UE may report the RLF event to any subsequent serving base station, and that serving base station may then forward this RLF event report to the base station that was serving the

35

03 08 18

5 UE at the time of the RLF event (which may then carry out the remaining steps of the second process). The base station may also note the next serving base station as a candidate target base station for a future blind handover. Alternatively, each base station in the network may forward each RLF event report to a centralised network node, which collates the information of all RLF events for all UEs connected to all base stations in the network, and thereafter perform the remaining steps of the second process of the first embodiment.

10 Furthermore, in the second process outlined above, the first base station instructs the UEs to report their locations following a trigger condition that the count of occurrences of RLF events exceeds a threshold. The skilled person will understand that other forms of trigger event (such as a rate of occurrences of RLF events) may be used instead.

15 It is also non-essential that the cellular network is divided into the particular number of geographical regions identified below, and the method may be implemented with any number of successively smaller regions. Furthermore, the regions may be of any shape, but square was used in the above examples for simplicity.

20 The skilled person will understand that any combination of features is possible within the scope of the invention, as claimed.

CLAIMS

1. A method in a cellular telecommunications network, the cellular
5 telecommunications network including a base station having a coverage area, and
further including a plurality of User Equipment, UE, located within the base station's
coverage area, the method comprising the steps of:
instructing a first plurality of UEs to report their location;
associating an occurrence of a connection performance indication for each UE of the
10 first plurality of UEs with a reported location for that UE;
defining a first geographical region in which the density of reported locations
associated with occurrences of connection performance indications is above a first
density threshold;
defining a second geographical region in which the density of reported locations
15 associated with occurrences of connection performance indications is above a second
density threshold, wherein the area of the first geographical region is greater than the
area of the second geographical region;
instructing a second plurality of UEs within the first geographical region to report their
location at a first reporting rate; and
20 instructing a third plurality of UEs within the second geographical region to report their
location at a second reporting rate.

2. A method as claimed in Claim 1, further comprising the initial step of:
25 determining that a count of occurrences of connection performance indications for one
or more UEs of the plurality of UEs satisfies a threshold.

3. A method as claimed in either Claim 1 or Claim 2, wherein the connection
performance indication is a Radio Link Failure, RLF.

30 4. A method as claimed in any one of Claims 1 to 3, performed by a first base
station.

5. A method as claimed in any one of Claims 1 to 3, performed by a network node,
wherein the network node is in communication with one or more base stations.

21 08 18

15

20

25

30

35

6. A computer program comprising instructions which, when the program is executed by a computer, cause the computer to carry out the method of any one of the preceding claims.

5 7. A computer-readable data carrier having stored thereon the computer program of Claim 6.

10 8. A network node for a cellular telecommunications network, the network including a plurality of User Equipment, UE, the network node comprising:
a transceiver configured to receive data from the plurality of UEs;
memory configured to store said data; and
a processor configured to perform the steps of any one of Claims 1 to 3.

9. A network node as claimed in Claim 8, being a base station.

21 08 18¹⁵