



US 20130341240A1

(19) **United States**

(12) **Patent Application Publication**
Chen et al.

(10) **Pub. No.: US 2013/0341240 A1**

(43) **Pub. Date: Dec. 26, 2013**

(54) **BOXES AND TRAYS USED TO HOLD LCD PANELS**

Publication Classification

(75) Inventors: **Shih Hsiang Chen**, Shenzhen (CN);
Yi-cheng Kuo, Shenzhen (CN); **Jiahe Cheng**, Shenzhen (CN)

(51) **Int. Cl.**
B65D 85/86 (2006.01)

(52) **U.S. Cl.**
USPC **206/722; 206/701**

(73) Assignee: **SHENZHEN CHINA STAR OPTOELECTRONICS TECHNOLOGY CO, LTD.**, Shenzhen, Guangdong (CN)

(57) **ABSTRACT**

(21) Appl. No.: **13/582,744**

(22) PCT Filed: **Jun. 28, 2012**

(86) PCT No.: **PCT/CN2012/077745**

§ 371 (c)(1),
(2), (4) Date: **Sep. 5, 2012**

The present invention publishes a box and a tray used to hold LCD panels. The tray comprises a carrying part, a supporting part, and buffering items. The carrying part is used to carry the LCD panel. The supporting part is located on the sides of the carrying part, and the supporting part comprises compartment slots. The buffering items are placed inside the compartment slots in order to improve the structural strength of the supporting part. The embodiment of the present invention improves the structural strength of the tray through the effects of buffering items. It also controls the production costs and avoids damages to LCD panels during transport caused due to insufficient strength of the tray.

(30) **Foreign Application Priority Data**

Jun. 26, 2012 (CN) 201210213636.5

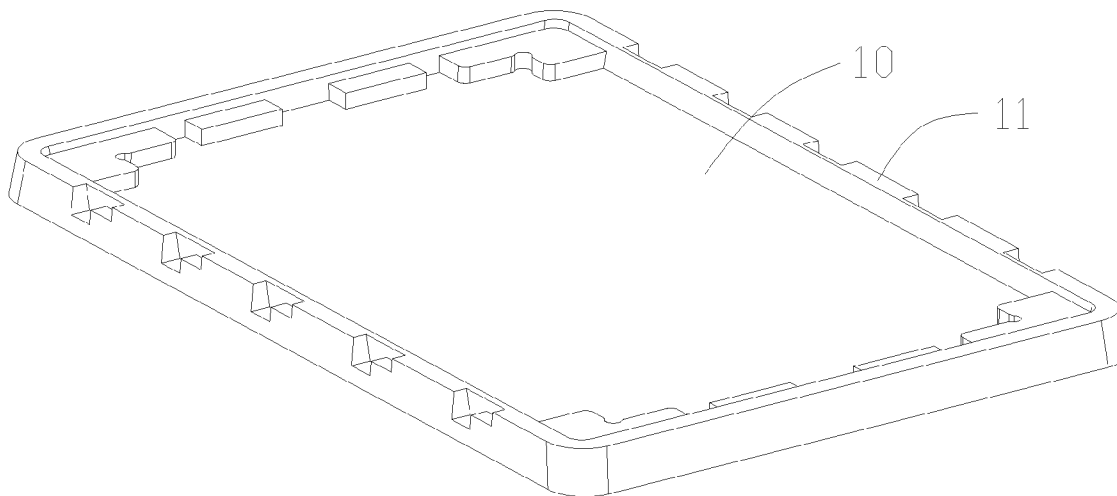

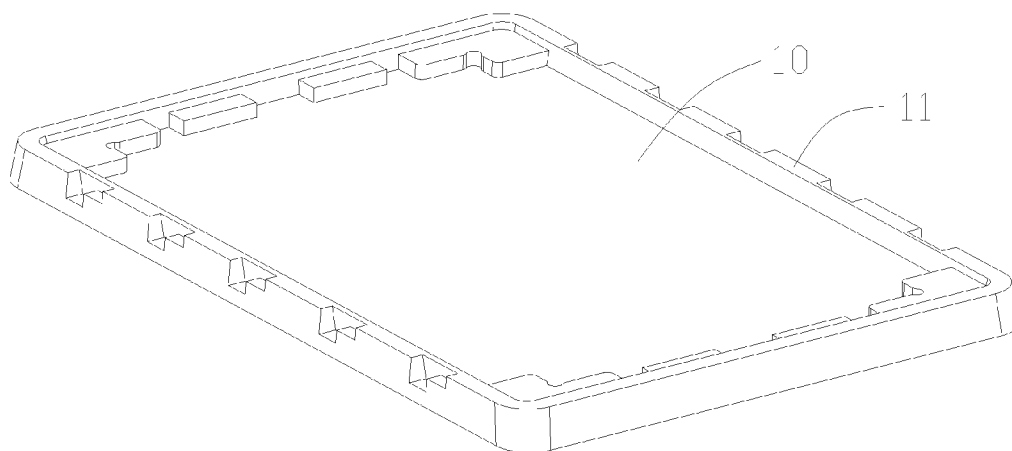

Figure 1

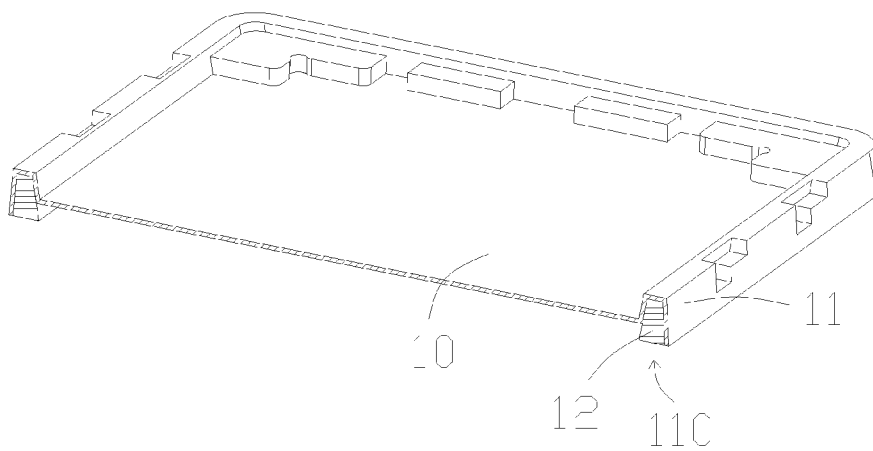

Figure 2

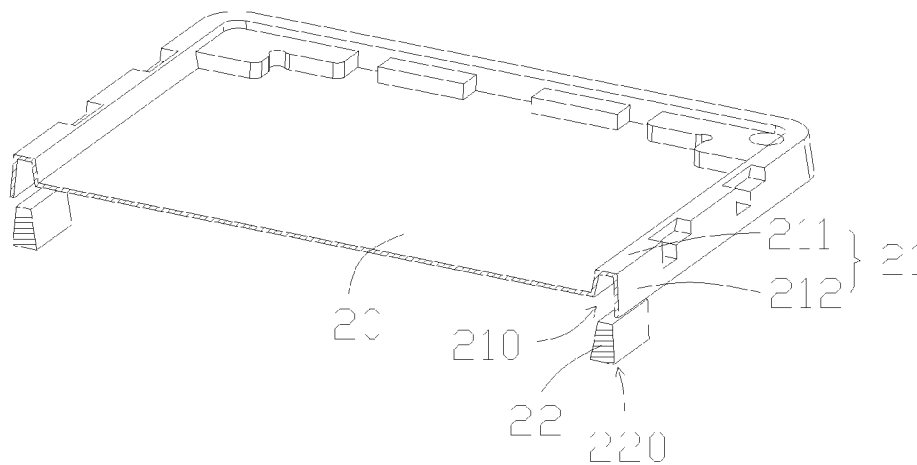

Figure 3

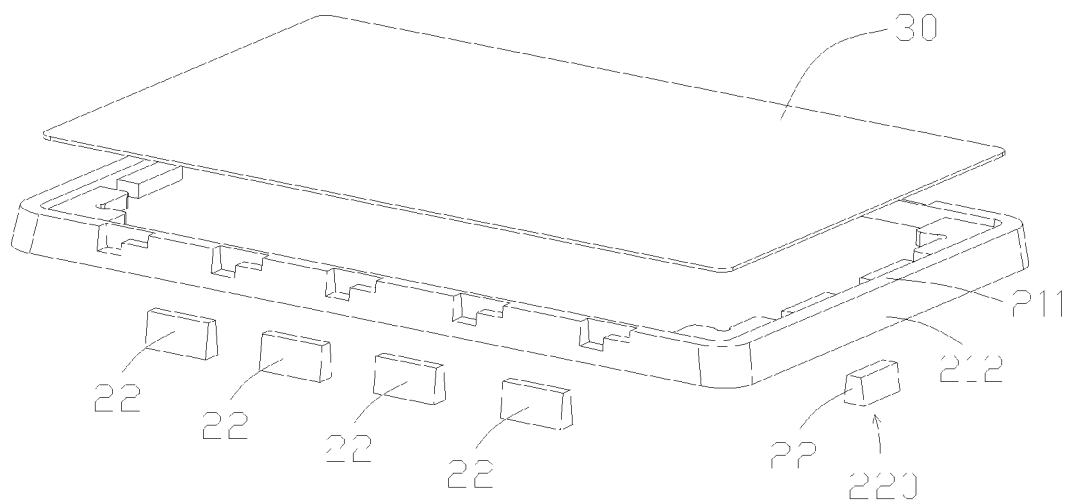

Figure 4

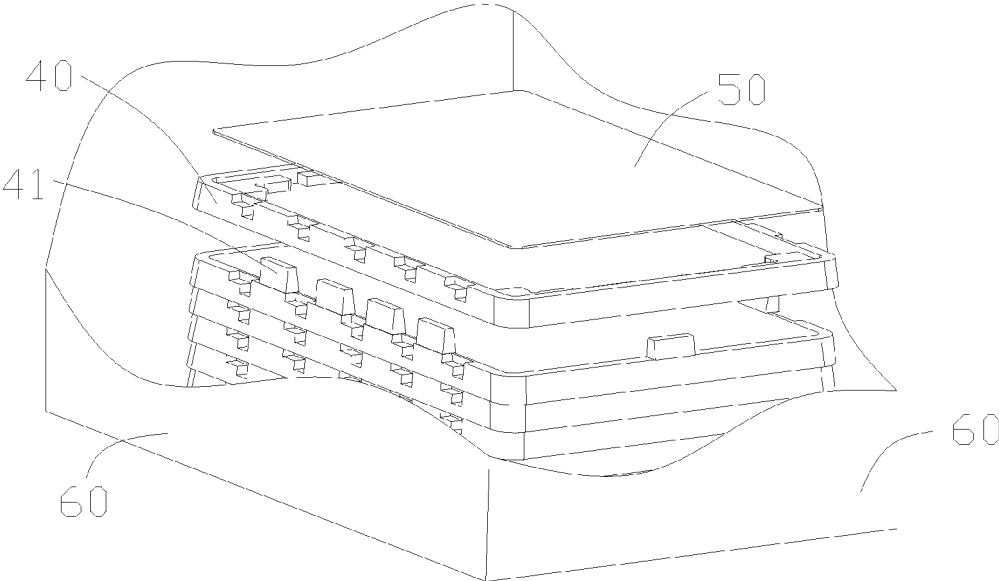

Figure 5

BOXES AND TRAYS USED TO HOLD LCD PANELS

FIELD OF THE INVENTION

[0001] The present invention relates to the field of Liquid Crystal Display (LCD) panel packing, specifically relating to boxes and trays used to hold LCD panels during packaging and transportation.

BACKGROUND OF THE INVENTION

[0002] Due to reasons such as technology and production cost, existing, technology generally requires different manufacturers to collaborate and work together in order to produce final LCD devices. For example, after the binding chip Open Cell (LCD panel) is manufactured, it needs to be transported to module plants or whole plants fix installation of LCD devices before the products can ultimately be sold to end users.

[0003] In the process of packaging and transporting LCD panels to module plants or whole plants, tools such as boxes are required for packing. Boxes are used not only to hold LCD panels but also to protect the panels. In order to further protect the LCD panels, specific trays also need to be used to hold the panels.

[0004] When a conventional tray is used, it holds the LCD panel through its carrying part and supporting part, which is on the sides of the carrying part. However, to lower costs, the supporting part generally uses a relatively simple structure. For example, a structure with a few fixed pins might be used. The strength of such structure is relatively poor. The weight of the LCD panel itself or the bumpy ride during transport might cause uneven pressure to the supporting part of the tray, causing the supporting part to deform. Subsequently, the LCD panel might be squeezed or scratched, resulting in unnecessary damages and losses.

SUMMARY OF THE INVENTION

[0005] To at least partially solve the problem described above, an embodiment of the present invention provides a box used for holding LCD panels, wherein the box comprises a box enclosure and trays inside the enclosure, wherein the tray comprises a carrying part, a supporting part, and buffering items. The carrying part is used to carry LCD panels. The supporting part is located on the sides of the carrying part, wherein the supporting part comprises a first supporting part, which is formed in one piece with the carrying part, and a second support part. The first supporting part connects with the carrying part, and the second supporting part connects with the first supporting part. The first supporting part and the second supporting part are folded to form compartment slots. The buffering, items are placed inside the compartment slots in order to improve the structural strength of the supporting part.

[0006] According to the embodiment of the present invention, the buffering item comprises a tightening adapter with a gradient structure. When sidewalls of this tightening adapter and the compartment slot squeeze up against each other, an interferece fit is achieved.

[0007] To at least partially solve the problem described above, another embodiment of the present invention provides a tray used to hold LCD panels, comprising a carrying part, a supporting part, and buffering items. The carrying part is used to carry LCD panels. The supporting part is located on the

sides of the carrying part and the supporting part comprises compartment slots. The buffering items are placed inside the compartment slots to increase the structural strength of the supporting part.

[0008] According to the embodiment of the present invention, the supporting part comprises a first supporting part and a second supporting part. The first supporting part is connected with the carrying part, and the second supporting part connects with the first supporting part. Compartment slots are formed between the first supporting part and the second supporting part.

[0009] According to the embodiment of the present invention, the carrying part, the first supporting part, and the second supporting part are formed in one piece. By folding the first supporting part and the second supporting part, compartment slots are formed.

[0010] According to the embodiment of the present invention, the opening of the compartment slots is located on the other side of the carrying part, opposite from the side that is carrying the LCD panel.

[0011] According to the embodiment of the present invention, the carrying part has multiple sides. The supporting part is located along these sides and surrounds the carrying part.

[0012] According to the embodiment of the present invention, the compartment slot has multiple instances, and they are located on and spaced over the multi-sided supporting part. The buffering item also has multiple instances and they are separately placed into the multiple compartment slots.

[0013] According to the embodiment of the present invention, the buffering item comprises a tightening adapter with a gradient structure. When sidewalls of this tightening adapter and the compartment slot squeeze up against each other, an interferece fit is achieved.

[0014] According to the embodiment of the present invention, the buffering item can be made of polystyrene, polypropylene foam, or polyethylene foam materials.

[0015] To at least partially solve the problem described above, an additional embodiment of the present invention provides a box used to hold LCD panels. The box comprises a box enclosure and trays placed inside the box enclosure. The tray comprises a carrying part, a supporting part, and buffering items. The carrying part is used to carry LCD panels. The supporting part is located on the sides of the carrying part, and the supporting part comprises compartment slots. The buffering items are placed inside the compartment slots to increase the structural strength of the supporting part.

[0016] According to the embodiment of the present invention, the tray has multiple instances. Multiple trays are stacked and placed inside the box enclosure. The supporting parts of every two adjacent. trays are abutted to each other. A compartment space is formed between every two adjacent trays for holding, an LCD panel.

[0017] According to the embodiment of the present invention, the supporting part comprises a first supporting part and a second supporting part. The first supporting part is connected with the carrying part, and the seconds supporting part is connected with the first supporting part. Compartment slots are formed between the first supporting part and the second supporting part.

[0018] According to the embodiment of the present invention, the carrying part, the first supporting part, and the second supporting part are formed in one piece. By folding the first supporting part and the second supporting part, compartment slots are formed.

[0019] According to the embodiment of the present invention, the buffering item comprises a tightening adapter with a gradient structure. When sidewalls of this tightening adapter and the compartment slot squeeze up against each other, an interference fit is achieved.

[0020] According to the embodiment of the present invention, the buffering item can be made of polystyrene, polypropylene foam, or polyethylene foam materials.

[0021] The present embodiment utilizes boxes and trays used for holding LCD panels, when carrying LCD panels during transport, by placing buffering items inside compartment slots and through the effects of these buffering items, the support intensity of the supporting part is increased and hence the structural strength of the tray is also increased. Without increasing the materials of the tray, the present embodiment increases the structural strength of the tray, controls the production costs, and effectively avoids potential losses incurred due to damages of LCD panels caused by insufficient structural strength of the tray.

BRIEF DESCRIPTION OF THE DRAWINGS

[0022] FIG. 1 is a schematic view showing the structure of a tray of an embodiment of the present invention.

[0023] FIG. 2 shows the sectional view of the tray shown in Figure

[0024] FIG. 3 is a schematic view showing structure of a tray of another embodiment of the present invention.

[0025] FIG. 4 illustrates the way an LCD panel fits with the tray shown in FIG. 3.

[0026] FIG. 5 is a schematic view showing the structure of a box of an additional embodiment of the present invention.

DETAILED DESCRIPTION OF THE PREFERRED EMBODIMENTS

[0027] Referring to FIG. 1 and FIG. 2, FIG. 1 is a schematic view showing, the structure of a tray of an embodiment of the present invention, and FIG. 2 shows the sectional view of the tray shown in FIG. 1.

[0028] In this embodiment, the tray is generally used to hold LCD panels, but it can also be used to hold precious fragile items such as glass substrates used for manufacturing LCD panels. Specifically and yet not to be constrained, the tray comprises but not limited to, carrying part 10, supporting part 11, and buffering item 12.

[0029] Carrying part 10 comprises a carrying mainbody and sides located at the edges of the carrying mainbody. Carrying part 10, through the carrying mainbody, carries LCD panels, etc. The carrying mainbody can be made with a number of raised areas to prevent the surface of the LCD panel from directly contacting the surface of the carrying mainbody and subsequently cause damages to the LCD panel. Additionally, the surface of the carrying mainbody for carrying the LCD panel can also be formed with specific patterns (not shown in figures) or be made with some stiffeners to increase the structural strength of carrying part 10. This method is generally understood by people in the present technology field and therefore is not further enumerated.

[0030] Supporting part 11 is located on the sides of carrying part 10. For instance, supporting part 11 can be located along these sides and surround carrying part 10. Alternatively, there can also be multi-segmented supporting part 11 spaced around the sides of carrying part 10. Supporting 11 comprises

compartment slots 110, wherein the shapes and sizes of compartment slots 110 are not to be constrained.

[0031] Buffering items 12 of the present embodiment are located inside compartment slots 110, wherein buffering items 12 can be made of materials with recovery capabilities such as elastic materials, rigid materials, or flexible materials. Through effects of buffering item 12, the structural strength of supporting part 11 can be effectively increased, thus increasing the structural strength of the tray.

[0032] When carrying LCD panels during transport, through the effects of buffering item 12, the present embodiment increases the support intensity of supporting part 11 and hence also increases the structural strength of the tray. Without increasing the materials of the tray, the present embodiment increases the structural strength of the tray, controls the production costs, and effectively avoids potential losses incurred due to damages of LCD panels caused by insufficient structural strength of the tray.

[0033] Referring to FIG. 3 and FIG. 4, FIG. 3 is a schematic view showing structure of a tray of another embodiment of the present invention, and FIG. 4 illustrates the way an LCD panel fits with the tray shown in FIG. 3.

[0034] The tray comprises but not limited to carrying part 20, supporting part 21, and buffering item 22. Carrying part 20, supporting part 21, and buffering item 22 work together to carry LCD panel 30.

[0035] In addition, supporting part 21 comprises first supporting part 211 and second supporting part 212, each interconnected with one another. One end of first supporting part 211 connects with carrying part 20. The other end of supporting part 211 connects with second supporting part 212. In other words, first supporting part 211 is in between carrying part 20 and second supporting part 212. It should be noted that in order to save the craft process, carrying part 20, first supporting part 211, and second supporting part 212 can be made in one piece; it is not to be constrained.

[0036] It is noteworthy that compartment slot 210 of the present embodiment is formed through first supporting part 211 and second supporting part 212. Compartment slot 210 has an open cap shape as shown in FIG. 3. Specifically, compartment slot 210 can be formed by folding first supporting part 211 and second supporting part 212. Also, opening of compartment slot 210 is located at the other side of the carrying part 20, opposite from the side that is carrying LCD panel 30.

[0037] When in operation, LCD panel 30 squeezes carrying part 20, carrying part 20 stretches first supporting part 211 and bents downwards. Then, compartment slot 210 is pressured and becomes deformed, and it gradually squeezes buffering item 22. Through the effects of buffering item 22, the deformation of compartment slot 210 is minimized, thus, avoiding first supporting part 211 from bending downwards and effectively increasing the structural strength of supporting part 21. Of course, in other embodiments, the opening of compartment slot 210 can also be on the same side of carrying part 20 as the side that is carrying LCD panel 30. This method is generally understood by people in the present technology field and therefore is not further enumerated.

[0038] It should be noted that carrying part 20 could have multiple sides, preferably formed into a rectangular shape similar to that of LCD panel 30. Then, supporting part 21 is located along these sides and surrounds carrying part 20. The compartment slot 210 has multiple instances and they are located on and spaced over the the multi-sided supporting part

21. The buffering item **22** also has multiple instances and they are placed inside the multiple compartment slots **210**. Generally speaking, the number of compartment slots **210** is the same as the number of buffering items **22**. However, compartment slot **210** could also be formed by a connected annular shape, and multiple buffering items **22** are placed inside and spaced out in such compartment slot **210**.

[0039] In addition, buffering item **22** could be made of segments cut from rubber or silicone. It could also be made of specific materials such as polystyrene, polypropylene foam, or polyethylene foam. It is not to be constraint on how buffering item **22** is made. In order to prevent buffering item **22** from falling out from compartment slot **210**, buffering item **22** could be setup with a tightening adapter **220** with a gradient structure. When sidewall of this tightening adapter **220** and the compartment slot **210** squeeze up against each other, an interference fit is achieved.

[0040] When carrying LCD panels during transport, through the effects of buffering item **22**, the present embodiment increases the support intensity of supporting part **21** and hence also increases the structural strength of the tray. Compartment slot **210** adopted its opening being located on the other side of the carrying part **20**, opposite from the side that is carrying the LCD panel **30**, and its opening is formed by the folding method. This saves the manufacturing craft process and increases the production efficiency.

[0041] Referring to FIG. **5**, it is a schematic view showing the structure of a box of an additional embodiment of the present invention.

[0042] In this embodiment, the box includes tray **40** and box enclosure **60**. Wherein, box enclosure **60** is only partially shown in the drawing. Specifically, it can be a conventional box. Alternatively, it can also be tailor made based on needs. It is not to be constrained. Tray **40** of the present embodiment includes buffering item **41** as described above. This method is generally understood by people in the present technology field and therefore is not further enumerated.

[0043] In actual operations, tray **40** is placed inside box enclosure **60** and LCD panel **50** is carried on tray **40**. In addition, tray **40** could have multiple instances and these trays **40** could be stacked together and placed inside box enclosure **60**. The supporting parts of every two adjacent trays **40** are abutted to each other. A compartment space is formed between every two adjacent trays **40**, and LCD panel **50** is placed in this space. Of course, multiple trays **30** can also be interval placed in box enclosure **60**. It is not to be constrained.

[0044] Tray **40** of present embodiment increases the intensity of support of the supporting part through effects of buffering item **41**. It subsequently also increases the structural strength of tray **40**. Without increase the materials of tray **40**, the present embodiment increases the structural strength of tray **40**. It also controls the production costs and effectively avoids losses incurred due to damages of LCD panel **50** caused by insufficient structural strength of the tray **40**.

[0045] Embodiments of the present invention have been described, but not intending to impose any unduly constraint to the appended claims. Any modification of equivalent structure or equivalent process made according to the disclosure and drawings of the present invention, or any application thereof, directly or indirectly, to other related fields of technique, is considered encompassed in the scope of protection defined by the claims of the present invention.

1. A box used to hold LCD panels, wherein, comprises a box enclosure and trays inside the box enclosure. Each tray comprises:

- a carrying part, used to carry LCD panels;
- a supporting part, located on sides of the carrying part; wherein, the supporting part comprises a first supporting part and a second supporting part formed in one piece with the carrying part; wherein the first supporting part connects with the carrying part and the second supporting part connects with the first supporting part;
- wherein, the first supporting part and the second supporting part are folded to form compartment slots;
- buffering items, placed inside the compartment slots to increase the structural strength of the supporting part.

2. The box according to claim **1**, wherein, the buffering item comprises a tightening adapter with a gradient structure. When sidewalls of this tightening adapter and the compartment slot squeeze up against each other, an interference fit is achieved.

3. A tray used to hold LCD panels, wherein, comprises:

- a carrying part, used to carry LCD panels;
- a supporting part, located on the sides of the carrying part, wherein the supporting part comprises compartment slots;
- buffering items, placed inside the compartment slots to increase the structural strength of the supporting part.

4. The tray according to claim **3**, wherein, the supporting part comprises a first supporting part and a second supporting part. The first supporting part connects with the carrying part, and the second supporting part connects with the first supporting part. The first supporting part and the second supporting part form in between the compartment slots.

5. The tray according to claim **4**, wherein, the carrying part, the first supporting part and the second supporting part are formed in one piece. The first supporting part and the second supporting part are folded to form compartment slots.

6. The tray according to claim **5**, wherein, the opening of the compartment slot is located on the other side of the carrying part, opposite from the side that is carrying the LCD panel.

7. The tray according to claim **3**, wherein, the carrying part has multiple sides. The supporting part is located along these sides and surrounds the carrying part.

8. The tray according to claim **7**, wherein, the compartment slot has multiple instances, and they are located on and spaced over the multi-sided supporting part. The buffering item has multiple instances and they are separately placed into the multiple compartment slots.

9. The tray according to claim **3**, wherein, the buffering item comprises a tightening adapter with a gradient structure. When sidewalls of this tightening adapter and the compartment slot squeeze up against each other, an interference fit is achieved.

10. The tray according to claim **3**, wherein, the buffering item is made of polystyrene, polypropylene foam, or polyethylene foam materials.

11. A box used to hold LCD panels, wherein, comprises a box enclosure a trays placed inside the box enclosure. Each tray comprises:

- a carrying part, used to carry LCD panels;
- a supporting part, located on the sides of the carrying part, wherein the supporting part comprises compartment slots;

buffering items, placed inside the compartment slots to increase the structural strength of the supporting part.

12. The box according to claim **11**, wherein, the tray has multiple instances. Multiple trays are stacked and placed inside the box enclosure. The supporting parts of every two adjacent trays are abutted to each other. A compartment space is formed between every two adjacent trays for holding an LCD panel.

13. The box according to claim **11**, wherein, the supporting part comprises a first supporting part and a second supporting part. The first supporting part connects with the carrying part, and the second supporting part connects with the first supporting part. The first supporting part and the second supporting part form in between them the compartment slots.

14. The box according to claim **13**, wherein, the carrying part, the first supporting part, and the second supporting part are formed in one piece. The first supporting part and the second supporting part are folded to form compartment slots.

15. The box according to claim **11**, wherein, the buffering item comprises a tightening adapter with a gradient structure. When sidewalls of this tightening adapter and the compartment slot squeeze up against each other, an interference fit is achieved.

16. The box according to claim **11**, wherein, the buffering item is made of polystyrene, polypropylene foam, or polyethylene foam materials.

* * * * *