

(12) **UK Patent Application** (19) **GB** (11) **2481631** (13) **A**

(43) Date of A Publication

04.01.2012

(21) Application No: **1011076.5**

(22) Date of Filing: **01.07.2010**

(51) INT CL:
A61L 9/14 (2006.01) **A01M 1/20** (2006.01)
A61L 9/12 (2006.01)

(56) Documents Cited:
EP 0092359 A

(58) Field of Search:
INT CL **A01M, A01N, A01P, A61L, A61M**
Other: **ONLINE: WPI, EPODOC, TXTE, TXTT, TXTKRT**

(71) Applicant(s):
Reckitt & Colman (Overseas) Limited
(Incorporated in the United Kingdom)
103-105 Bath Road, Slough, Berkshire, SL1 3UH,
United Kingdom

(72) Inventor(s):
Natalie Ingledew
Loic Marouse
Steve Walsh

(74) Agent and/or Address for Service:
Reckitt Benckiser Corporate Services Limited
Dansom Lane, HULL, HU8 7DS, United Kingdom

(54) Title of the Invention: **Devices and methods for improved delivery of volatile liquids**
Abstract Title: **Emanation device**

(57) An emanation device is described which comprises: a replaceable refill 10 of volatile liquid containing one or more active materials wherein the active material comprises at least one of: a fragrance; an insecticide; a fungicide; a pesticide; a sanitising material; and/or a pharmaceutical; wherein the refill comprises a sealed reservoir containing said volatile liquid and a porous wick 9 which extends from the interior of the reservoir to the exterior thereof; and wherein the device comprises: an air pump 2; a fluid conduit 5 in fluid communication with the air pump such that, in use, air pumped by the pump will flow through the fluid conduit; a nozzle 6 located at the end of the fluid conduit remote from the air pump; a ejector constriction 14 provided in the fluid conduit adjacent or substantially adjacent the nozzle; a liquid conduit 8 provided adjacent the ejector constriction and in fluid communication with the fluid conduit at one end thereof, and open at the other end to receive liquid therein; characterised in that the liquid conduit is located within the porous wick. The liquid conduit may be made from a substantially rigid material and the open end of the liquid conduit provided with a sharpened point or the like for penetrating the wick. Also claimed is a method of emanating a volatile liquid using the device. The device may be able to receive more than one refill.

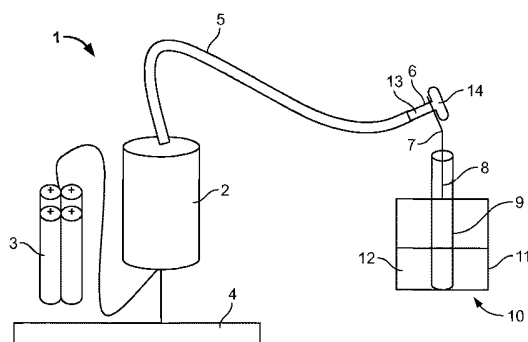

FIG. 1

GB 2481631 A

01 08 11

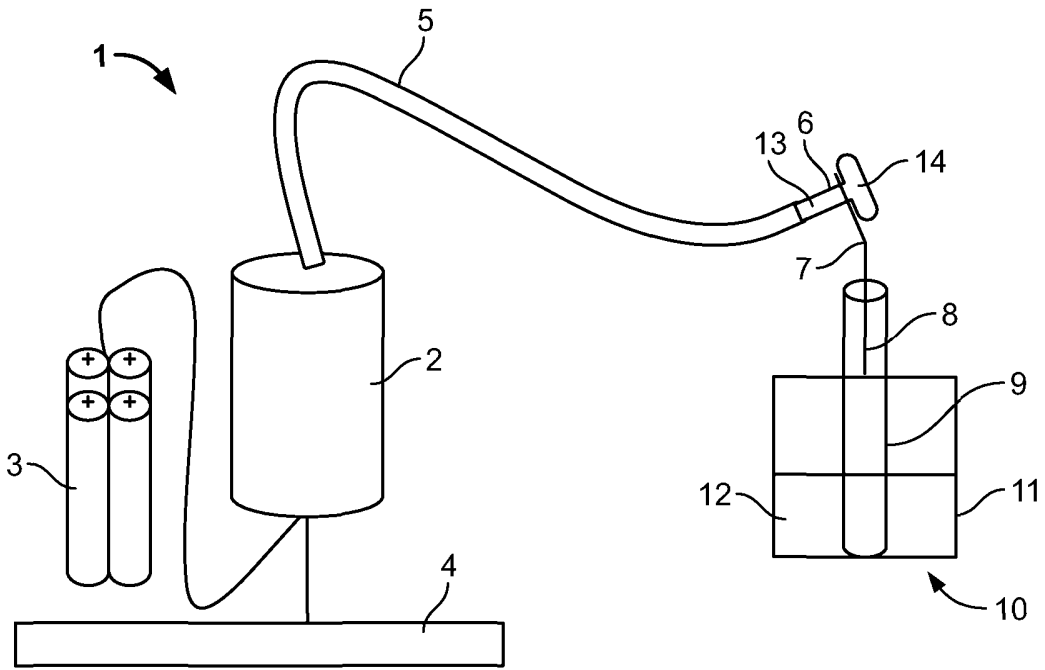

FIG. 1

Devices and Methods for Improved Delivery of Volatile Liquids

Field of the Invention

The present invention relates to devices and methods for improved airborne delivery of volatile liquids containing one or more active materials wherein the active material comprises at least one of: a fragrance; an insecticide; a fungicide; a pesticide; a sanitising material; and/or a pharmaceutical.

Background

Volatile liquids containing one or more active materials wherein the active material comprises at least one of: a fragrance; an insecticide; a fungicide; a pesticide; a sanitising material; and/or a pharmaceutical are delivered within the domestic environment via a variety of mechanisms. Devices are available with heaters disposed therein to increase the rate of emanation from a surface saturated with the liquid, such a surface could be a wick saturated with a fragranced liquid and the heater is located adjacent the wick surface and nearby a chimney to heat the liquid on the wick surface and cause it to more readily evaporate and disseminate into the surrounding environment through the chimney.

Alternatively such volatile liquids can be loaded in an aerosol canister, the canister holds the liquid under pressure and when the canister valve is opened the liquid is forced out. The liquid is provided with a propellant which evaporates inside the canister to maintain an even pressure and, outside the canister, assist with the mechanical break up of the liquid by evaporating rapidly. Suitable propellants include volatile hydrocarbons such as propane, butane or isobutane.

Aerosols generally provide a satisfactory spray performance but since they require manual operation by a user, they are not considered to be particularly convenient for routine use. Automatic aerosol activation devices exist for operation with metered dose aerosols. These devices are operable to periodically actuate the aerosol to cause a dose of the liquid to be sprayed.

Whilst the automation of the device overcomes the problem of manual operation of a canister, the use of aerosols containing such propellants is becoming increasingly less desirable since these volatile hydrocarbons carry the disadvantage of being flammable, the rising cost of oil is rendering them increasingly expensive and they also carry the further disadvantage of being an atmospheric source of carbon which is deemed to not be environmentally sensitive.

In the field of air freshening it is generally preferred to use a fragranced volatile liquid/air freshening liquids comprising several components. These components often possess different volatilities which can lead to emission problems. The effect of fractionation can be particularly pronounced for powered emanation devices using a heater to effect emanation such as a plug-in emanation device or the like.

In such device a build-up phenomenon can occur in which an accumulation of volatile liquid components with the lowest comparative volatilities can occur leading to an undesirable non-uniform emanation profile for the liquid. This phenomenon can produce an olfactory sensation wherein the fragrance character changes over the course of emanation of a quantity of the fragranced volatile liquid such that the 'high notes' of a fragrance are the first to be evaporated when the wicking material is first exposed to the fragranced liquid, and the 'low notes' are evaporated thereafter.

Accordingly, it is an object of the present invention to provide a device that is capable of addressing the abovementioned performance drawbacks and other drawbacks that will be appreciated by a person skilled in the art.

Summary of Invention

According to a first aspect of the present invention there is provided therefore an emanation device comprising:

a replaceable refill of volatile liquid containing one or more active materials wherein the active material comprises at least one of: a fragrance; an insecticide; a fungicide; a pesticide; a sanitising material; and/or a pharmaceutical; wherein the refill comprises a sealed reservoir containing said volatile liquid and a porous wick which extends from the interior of the reservoir to the exterior thereof; and wherein the device comprises:

an air pump;

a fluid conduit in fluid communication with the air pump such that, in use, air pumped by the pump will flow through the fluid conduit;

a nozzle located at the end of the fluid conduit remote from the air pump;

a ejector constriction provided in the fluid conduit adjacent or substantially adjacent the nozzle;

a liquid conduit provided adjacent the ejector constriction and in fluid communication with the fluid conduit at one end thereof, and open at the other end to receive liquid therein;

characterised in that the liquid conduit is located within the porous wick.

According to a second aspect of the present invention there is provided therefore an emanation device comprising:

two or more replaceable refills of volatile liquid containing one or more active materials wherein the active material comprises at least one of: a fragrance; an insecticide; a fungicide; a pesticide; a sanitising material; and/or a pharmaceutical; wherein the refills each comprise a sealed reservoir containing said volatile liquid and a porous wick which extends from the interior of the reservoir to the exterior thereof; and wherein the device comprises:

- one or more air pumps;
- two or more fluid conduits corresponding to the number of replaceable refills, wherein said fluid conduits are in fluid communication with the or each air pump such that, in use, air pumped by the pump(s) will flow through the fluid conduits;
- a nozzle located at the end of each fluid conduit remote from the air pump(s);
- a ejector constriction provided in each fluid conduit adjacent or substantially adjacent the nozzle;
- a liquid conduit provided adjacent each ejector constriction and in fluid communication with the respective fluid conduit at one end thereof, and open at the other end to receive liquid therein; characterised in that each liquid conduit is located within respective porous wicks of said two or more replaceable refills.

Devices according to either the first or second aspect of the present invention have been found to be particularly advantageous as they are capable of spraying the volatile liquid at a uniform consistency thus avoiding the drawbacks of fractionation and/or build-up phenomena.

The liquid conduit is preferably made from a rigid or substantially rigid material such as a metal, alloy or plastics material, this may be advantageous in allowing said conduit to penetrate the wick. The open end of the liquid conduit may be provided with a sharpened point or the like to assist with penetration of the wick.

The liquid conduit is preferably provided in a length that is less than the length of the wick, in other words the liquid conduit preferably extends from the fluid conduit to a length that will not contact a base interior surface of the refill reservoir. In this arrangement the transport of the liquid from the reservoir of the refill to and past the nozzle of the device is achieved by the liquid being transported by capillary action into the wick and then transported via suction imposed by the ejector constriction acting in cooperation with the pumped air up into the liquid conduit and out past the nozzle. This arrangement is preferred as it is easier for a user of the device of the present invention to insert the liquid conduit partially into the wick rather than insert it along the entire length of the wick. This arrangement is also preferred as the wick is more efficient at ensuring all of the liquid in the reservoir is taken up into the wick since it is less susceptible to not contacting pooled liquid in the lower portions of the reservoir.

The refill is preferably a commercially available refill of volatile liquid such as that sold under the brand AIRWICK® for use with a mains electric fragrance diffuser sold under the same brand. The refill may be made from a reservoir that is partially or completely transparent thus allowing a user to monitor the liquid level therein. Preferably the reservoir is made from glass or a substantially rigid plastics material. The reservoir is preferably sealed with a plug having an aperture therethrough, and the aperture is preferably sized to correspond to the diameter or cross-section of the wick thus securely holding the wick in a fixed position whilst substantially maintaining a liquid seal to substantially or completely prevent the leaking of liquid from the reservoir. The refill is preferably provided with a removable cap that surrounds the plug and the protruding wick to protect the wick and prevent emanation of the volatile liquid from the wick until emanation of the volatile liquid is required.

The wick is preferably made from a wrapped fibrous material, such as wrapped cellulose or the like. The wick may be made from any porous material wherein said porous material sufficiently malleable to permit the liquid conduit to be at least partially inserted therein.

The wick is preferably sized to extend from a base of reservoir to protrude through the plug or a reservoir seal to extend thereabove.

A further advantage of the present invention over typical devices used for emanating volatile liquids from a wicked replaceable refill, such as a mains electrical plug in diffuser, is that since heat is not used to drive the emanation of the volatile liquid, there will be no unsightly discolouration of the wick.

The device may be provided with refill securing means which are configured to retain the refill in a substantially fixed position relative to the device to ensure the safe operation of the device during use and prevent the likelihood of damage to the liquid conduit.

The air pump is preferably configured to pump air through the fluid conduit within a range of substantially 0.4 – 1.0 litres/min, and preferably substantially 0.6 – 0.8 litres/min.

The ejector constriction is preferably provided in the form of a nozzle insert, even more preferably said nozzle insert substantially fills the nozzle and permits the flow of volatile liquid therefrom.

The nozzle insert is preferably configured to extend from or adjacent the nozzle along the interior of the fluid conduit and may be provided at a rearward portion thereof that is remote from the nozzle with a channel. The channel may be inwardly tapered toward a forward portion thereof to,

in use, further lower the pressure and increase the speed of air pumped therethrough, forward of the inward taper may be provided a ejector constriction portion. Forward from said ejector constriction portion may be provided an expansion chamber. The liquid conduit preferably connects to the fluid conduit in the ejector constriction portion to be in fluid communication with the fluid conduit and/or the nozzle insert such that, in use, the decrease in pressure at the connection draws liquid up the liquid conduit into the fluid conduit and/or nozzle insert before being carried by the pumped air flow out of the nozzle or nozzle insert into the environment surrounding the device.

Alternatively the ejector constriction can be formed integrally with the fluid conduit adjacent the nozzle. As a further alternative the ejector constriction can be formed integrally with the nozzle.

The nozzle or nozzle insert may be provided with one or more break-up bars and/or swirl chambers in order to improve the mechanical break up of the volatile liquid being sprayed therefrom in use.

The device is preferably provided with a controller that is configured to control the air pump to control the spraying of volatile liquid from the device. Preferably the controller is provided with a timer to permit the controller to instruct the pump to operate for periods defined by the controller. The device may be provided with user input means to allow a user to instruct the controller how long to spray for and/or how often to spray for and/or the spray rate of the device.

The device may be provided with a sensor means which is connected to the controller wherein said sensor means is configured to detect a characteristic in the environment surrounding the device. The controller would preferably be operative to analyse an input from the sensor means and control the air pump to spray a determined amount of volatile liquid.

Preferably the sensor means is provided by at least one motion sensor means and/or at least one odour sensor means.

The motion sensor means may be provided in the form of at least one of: an infrared (IR) sensor; a laser sensor; and a sound sensor. The IR sensor, which is preferably a passive IR sensor, may be operable to detect radiation in the infrared spectrum, thus be capable of detecting the presence of a person or an animal within the vicinity of the device. The laser sensor may be operable to emit one or more laser beams and be adapted to detect when an object breaks the one or more beams by moving across the beam(s), thus indicating the presence of a person or an animal within the vicinity of the device. The sound sensor may be operable to detect sound within

the vicinity of the device and, preferably, once the detected sound exceeds a predefined level this is indicative of movement within the vicinity of the device.

The odour sensor means may be provided by a MOS sensor or the like and may be operable to detect common household odours (and the chemicals which constitute) these malodours. For example: kitchen malodour; bathroom malodour; tobacco smoke; pet odours; mould and/or mildew; body odour; fish; onions; garbage; fragrance from other products (such as detergents, polishes, cleaning products etc). To facilitate such detection the odour sensor means may be operable to detect at least some of the following chemical components: amines and nitrogen compounds; acids and/or sulphur compounds, such as mercaptans, thioacids, thioesters, sulfides, phenols and skatole.

The device of any of the above-mentioned aspects may be provided with an indicator wherein said indicator is operable to indicate to a user what function the device is currently performing. The indicator may be operable to provide a visual indication and/or provide an audible indication.

Preferably the indicator is configured to provide a visual indication by emitting light from one or more light sources, preferably one or more LEDs.

The one or more light sources may be adapted to emit a different colour of light to indicate the current function the device is performing. Additionally or alternatively, the one or more light sources may blink or flash to indicate the current function the device is performing.

Alternatively or additionally, the device may be operable to visually indicate the function currently being performed by the device via a screen. The screen may be an LCD screen that is adapted to provide a message to a user, for instance such messages could include "ON", "DISPENSING", "RESTING", "NORMAL MODE", "DETECTING MODE", "BOOST MODE", "OFF".

The device may be power by mains-supplied electricity and/or be battery powered and/or be powered by solar cells located on the device. Most preferably the device is battery powered however to improve the portability thereof. Indeed battery powered is preferred as the use of such power is consider to be particularly advantageous over typical devices used for emanating volatile liquids from a wicked replaceable refill, such as a mains electrical plug in diffuser, is that the device does not need to be located adjacent an electrical plug socket nor within an acceptable distance of the socket such that there can be a electrical power cord between the device and plug socket, thus providing true portability.

According to a third aspect of the present invention there is provided therefore a method of emanating a volatile liquid containing one or more active materials wherein the active material comprises at least one of: a fragrance; an insecticide; a fungicide; a pesticide; a sanitising material; wherein said method comprises the steps of:

- at least partially inserting a liquid conduit of a device according to either the first or second aspect of the present invention into a wick of a refill of volatile liquid containing one or more active materials;
- causing an air pump to pump air into a fluid conduit and out of a nozzle past a ejector constriction such that liquid is sucked from the wick into the liquid conduit and out of the nozzle into the environment surrounding the device.

According to a fourth aspect of the present invention there is provided therefore a fragrance emanation device for use with a replaceable refill of volatile liquid containing one or more active materials wherein the active material comprises at least one fragrance; wherein the refill comprises a sealed reservoir containing said volatile liquid and a porous wick which extends from the interior of the reservoir to the exterior thereof wherein the device comprises:

- an air pump;
- a fluid conduit in fluid communication with the air pump such that, in use, air pumped by the pump will flow through the fluid conduit;
- a nozzle located at the end of the fluid conduit remote from the air pump;
- a ejector constriction provided in the fluid conduit adjacent or substantially adjacent the nozzle;
- a liquid conduit provided adjacent the ejector constriction and in fluid communication with the fluid conduit at one end thereof, and open at the other end to receive liquid therein;
- characterised in that the liquid conduit is located within the porous wick.

According to a fifth aspect of the present invention there is provided therefore a fragrance emanation device for use with two or more replaceable refills of volatile liquid each containing one or more active materials wherein the active material comprises at least one fragrance; wherein the refills each comprise a sealed reservoir containing said volatile liquid and a porous wick which extends from the interior of the reservoir to the exterior thereof wherein the device comprises:

- one or more air pumps;
- two or more fluid conduits corresponding to the number of replaceable refills, wherein said fluid conduits are in fluid communication with the or each air pump such that, in use, air pumped by the pump(s) will flow through the fluid conduits;
- a nozzle located at the end of each fluid conduit remote from the air pump(s);
- a ejector constriction provided in each fluid conduit adjacent or substantially adjacent the nozzle;

a liquid conduit provided adjacent each ejector constriction and in fluid communication with the respective fluid conduit at one end thereof, and open at the other end to receive liquid therein; characterised in that each liquid conduit is located within respective porous wicks of said two or more replaceable refills.

Any of the features described herein may be combined with any of the above aspects in any combination.

Brief Description of the Drawings

Embodiments of the invention will now be described, by way of example only, with reference to the following drawing in which:

Fig. 1 illustrates an exploded view of the principle components of a device according to the present invention.

Description of an Embodiment

Fig.1 illustrates an exploded view of the principle components of the device 1 according to the present invention. The device 1 consists of an air pump 2 which is powered by batteries 3 and controlled by a controller 4 provided in the form of a PCB with suitable components attached thereto to facilitate control of the air pump 2.

The air pump 2 is shown in fluid communication with a fluid conduit 5 such that air pumped by the pump 5 is pumped into the fluid conduit 6. The pumped air passes along the fluid conduit through a nozzle insert 6 (discussed in greater detail below) and out of a nozzle (not shown). Connected to the fluid conduit 5 around the nozzle insert 6 is a liquid conduit 7.

The liquid conduit 7 is made from a rigid or substantially rigid material such as a metal, alloy or plastics material, and is of a generally tubular construction to permit volatile liquid to be transported therein. Although not shown, the open end 8 of the liquid conduit 7 is provided with a sharpened point or the like to assist the penetration of a wick 9 of a refill 10 of volatile liquid.

The refill 10 is preferably a commercially available refill of volatile liquid such as that sold under the brand AIRWICK® for use with a mains electric fragrance diffuser sold under the same brand. The refill 10 comprises a reservoir 11 that is partially or completely transparent thus allowing a user to monitor the volatile liquid 12 level therein. The reservoir 11 is sealed with a plug (not shown) having an aperture therethrough, and the aperture is sized to correspond to the diameter or cross-section of the wick 9 to securely hold it in a fixed position whilst substantially maintaining a liquid seal to substantially or completely prevent the leaking of liquid from the reservoir.

The wick 9 may be made from any porous material wherein said porous material sufficiently malleable to permit the liquid conduit 7 to be at least partially inserted therein. As shown in Fig. 1, the liquid conduit 7 is provided in a length that is less than the length of the wick 9 to permit the liquid conduit 7 to extend partially into the wick 9.

Although not shown in detail in Fig. 1, the nozzle insert 6 is configured to be held in place by the nozzle and extend therefrom along the interior of the fluid conduit 5. At a rearward portion 13 of the nozzle insert 6 a channel is provided which may be inwardly tapered toward a forward portion (i.e. toward the nozzle) thereof to, in use, further lower the pressure and increase the speed of air pumped therethrough. Forward of the inward taper may be provided an ejector constriction portion 14 and forward from said ejector constriction portion may be provided an expansion chamber. The liquid conduit 8 connects to the fluid conduit 5 in the ejector constriction 14 portion to be in fluid communication with the fluid conduit 5 and/or the nozzle insert 6 such that, in use, the decrease in pressure at the connection draws liquid up the liquid conduit 7 into the fluid conduit 5 and/or nozzle insert 6 before being carried by the pumped air flow out of the nozzle into the environment surrounding the device 1.

As shown in Fig. 1 the liquid conduit 7 extends from the fluid conduit 5 with a length that will permit the liquid conduit 7 to penetrate the wick 9 but not be sufficiently long to contact a base interior surface of the reservoir 11. This arrangement ensures that transport of the liquid 12 from the reservoir 11 is achieved by a combination of the liquid 12 being transported first by capillary action into the wick and subsequently transported via suction imposed by the ejector constriction acting in cooperation with the pumped air up into the liquid conduit 7 and out of the nozzle.

Although not illustrated, a device according to the second aspect of the present invention could be envisaged based on a multiplication of the features illustrated with reference to Fig. 1 and/or with variations made thereto within the scope of ordinary skill in the art of making emanation devices.

All of the features disclosed in this specification (including any accompanying claims, abstract and drawings), and/or all of the steps of any method or process so disclosed, may be combined in any combination, except combinations where at least some of such features and/or steps are mutually exclusive.

Each feature disclosed in this specification (including any accompanying claims, abstract and drawings) may be replaced by alternative features serving the same, equivalent or similar

purpose, unless expressly stated otherwise. Thus, unless expressly stated otherwise, each feature disclosed is one example only of a generic series of equivalent or similar features.

The invention is not restricted to the details of the foregoing embodiment(s). The invention extends to any novel one, or any novel combination, of the features disclosed in this specification (including any accompanying claims, abstract and drawings), or to any novel one, or any novel combination, of the steps of any method or process so disclosed.

Claims

1. An emanation device comprising:

a replaceable refill of volatile liquid containing one or more active materials wherein the active material comprises at least one of: a fragrance; an insecticide; a fungicide; a pesticide; a sanitising material; and/or a pharmaceutical; wherein the refill comprises a sealed reservoir containing said volatile liquid and a porous wick which extends from the interior of the reservoir to the exterior thereof; and wherein the device comprises:

an air pump;

a fluid conduit in fluid communication with the air pump such that, in use, air pumped by the pump will flow through the fluid conduit;

a nozzle located at the end of the fluid conduit remote from the air pump;

a ejector constriction provided in the fluid conduit adjacent or substantially adjacent the nozzle;

a liquid conduit provided adjacent the ejector constriction and in fluid communication with the fluid conduit at one end thereof, and open at the other end to receive liquid therein;

characterised in that the liquid conduit is located within the porous wick.

2. An emanation device comprising:

two or more replaceable refills of volatile liquid containing one or more active materials wherein the active material comprises at least one of: a fragrance; an insecticide; a fungicide; a pesticide; a sanitising material; and/or a pharmaceutical; wherein the refills each comprise a sealed reservoir containing said volatile liquid and a porous wick which extends from the interior of the reservoir to the exterior thereof; and wherein the device comprises:

one or more air pumps;

two or more fluid conduits corresponding to the number of replaceable refills, wherein said fluid conduits are in fluid communication with the or each air pump such that, in use, air pumped by the pump(s) will flow through the fluid conduits;

a nozzle located at the end of each fluid conduit remote from the air pump(s);

a ejector constriction provided in each fluid conduit adjacent or substantially adjacent the nozzle;

a liquid conduit provided adjacent each ejector constriction and in fluid communication with the respective fluid conduit at one end thereof, and open at the other end to receive liquid therein;

characterised in that each liquid conduit is located within respective porous wicks of said two or more replaceable refills.

3. An emanation device according to claim 1 or claim 2, wherein the liquid conduit is made from a rigid or substantially rigid material and the open end of the liquid conduit is provided with a sharpened point or the like.

4. An emanation device according to any preceding claim, wherein the liquid conduit is provided in a length that is less than the length of the wick.
5. An emanation device according to any preceding claim, wherein the wick is made from any porous material wherein said porous material sufficiently malleable to permit the liquid conduit to be at least partially inserted therein, and preferably the wick is made from a wrapped fibrous material.
6. An emanation device according to any preceding claim, wherein the wick is sized to extend from a base of reservoir to protrude through a plug or a reservoir seal to extend thereabove.
7. An emanation device according to any preceding claim, wherein the device is provided with refill securing means which are configured to retain the refill in a substantially fixed position relative to the device.
8. An emanation device according to any preceding claim, wherein the air pump is configured to pump air through the fluid conduit within a range of substantially 0.4 – 1.0 litres/min, and preferably substantially 0.6 – 0.8 litres/min.
9. An emanation device according to any preceding claim, wherein the ejector constriction is provided in the form of a nozzle insert.
10. An emanation device according to claim 9, wherein the nozzle insert is configured to extend from or adjacent the nozzle along the interior of the fluid conduit and is provided at a rearward portion thereof that is remote from the nozzle with a channel, and the channel is inwardly tapered toward a forward portion thereof to, in use, further lower the pressure and increase the speed of air pumped therethrough, and forward of the inward taper is provided a ejector constriction portion, and forward from said ejector constriction portion is provided an expansion chamber, wherein the liquid conduit connects to the fluid conduit in the ejector constriction portion to be in fluid communication with the fluid conduit and/or the nozzle insert such that, in use, the decrease in pressure at the connection draws liquid up the liquid conduit into the fluid conduit and/or nozzle insert before being carried by the pumped air flow out of the nozzle or nozzle insert into the environment surrounding the device.
11. An emanation device according to any of claims 1-8, wherein the ejector constriction is formed integrally with the fluid conduit adjacent the nozzle.

12. An emanation device according to any of claims 1-8, wherein the ejector constriction is formed integrally with the nozzle.
13. An emanation device according to any preceding claim, wherein the device is provided with a controller that is configured to control the air pump to control the spraying of volatile liquid from the device.
14. An emanation device according to claim 13, wherein the controller is provided with a timer to permit the controller to instruct the pump to operate for periods defined by the controller.
15. An emanation device according to claim 14, wherein the device is provided with user input means to allow a user to instruct the controller how long to spray for and/or how often to spray for and/or the spray rate of the device.
16. An emanation device according to any of claims 13-15, wherein the device is provided with a sensor means which is connected to the controller wherein said sensor means is configured to detect a characteristic in the environment surrounding the device, and wherein the controller is operative to analyse an input from the sensor means and control the air pump to spray a determined amount of volatile liquid.
17. An emanation device according to claim 16, wherein the sensor means is provided by at least one motion sensor means and/or at least one odour sensor means.
18. An emanation device according to any preceding claim, wherein the device is battery powered.
19. A method of emanating a volatile liquid containing one or more active materials wherein the active material comprises at least one of: a fragrance; an insecticide; a fungicide; a pesticide; a sanitising material; wherein said method comprises the steps of:
- at least partially inserting a liquid conduit of a device according to either the first or second aspect of the present invention into a wick of a refill of volatile liquid containing one or more active materials;
 - causing an air pump to pump air into a fluid conduit and out of a nozzle past a ejector constriction such that liquid is sucked from the wick into the liquid conduit and out of the nozzle into the environment surrounding the device.

20. A fragrance emanation device for use with a replaceable refill of volatile liquid containing one or more active materials wherein the active material comprises at least one fragrance; wherein the refill comprises a sealed reservoir containing said volatile liquid and a porous wick which extends from the interior of the reservoir to the exterior thereof wherein the device comprises:
an air pump;
a fluid conduit in fluid communication with the air pump such that, in use, air pumped by the pump will flow through the fluid conduit;
a nozzle located at the end of the fluid conduit remote from the air pump;
a ejector constriction provided in the fluid conduit adjacent or substantially adjacent the nozzle;
a liquid conduit provided adjacent the ejector constriction and in fluid communication with the fluid conduit at one end thereof, and open at the other end to receive liquid therein;
characterised in that the liquid conduit is located within the porous wick.

21. A fragrance emanation device for use with two or more replaceable refills of volatile liquid each containing one or more active materials wherein the active material comprises at least one fragrance; wherein the refills each comprise a sealed reservoir containing said volatile liquid and a porous wick which extends from the interior of the reservoir to the exterior thereof wherein the device comprises:
one or more air pumps;
two or more fluid conduits corresponding to the number of replaceable refills, wherein said fluid conduits are in fluid communication with the or each air pump such that, in use, air pumped by the pump(s) will flow through the fluid conduits;
a nozzle located at the end of each fluid conduit remote from the air pump(s);
a ejector constriction provided in each fluid conduit adjacent or substantially adjacent the nozzle;
a liquid conduit provided adjacent each ejector constriction and in fluid communication with the respective fluid conduit at one end thereof, and open at the other end to receive liquid therein;
characterised in that each liquid conduit is located within respective porous wicks of said two or more replaceable refills.

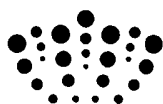

Application No: GB1011076.5

Examiner: Mr Chris Archer

Claims searched: 1-13

Date of search: 29 October 2010

Patents Act 1977: Search Report under Section 17

Documents considered to be relevant:

Category	Relevant to claims	Identity of document and passage or figure of particular relevance
A	-	EP 0092359 A (ASSOC INVESTMENTS) see whole document, especially the figures.

Categories:

X	Document indicating lack of novelty or inventive step	A	Document indicating technological background and/or state of the art.
Y	Document indicating lack of inventive step if combined with one or more other documents of same category.	P	Document published on or after the declared priority date but before the filing date of this invention.
&	Member of the same patent family	E	Patent document published on or after, but with priority date earlier than, the filing date of this application.

Field of Search:

Search of GB, EP, WO & US patent documents classified in the following areas of the UKC^X :

Worldwide search of patent documents classified in the following areas of the IPC

A01M; A01N; A01P; A61L; A61M

The following online and other databases have been used in the preparation of this search report

WPI, EPODOC, TXTE, TXTT, TXTKRT

International Classification:

Subclass	Subgroup	Valid From
A61L	0009/14	01/01/2006
A01M	0001/20	01/01/2006
A61L	0009/12	01/01/2006