

F. S. ROLFE.

SAND BAND FOR VEHICLES.

No. 304,239.

Patented Aug. 26, 1884.

Fig. 1.

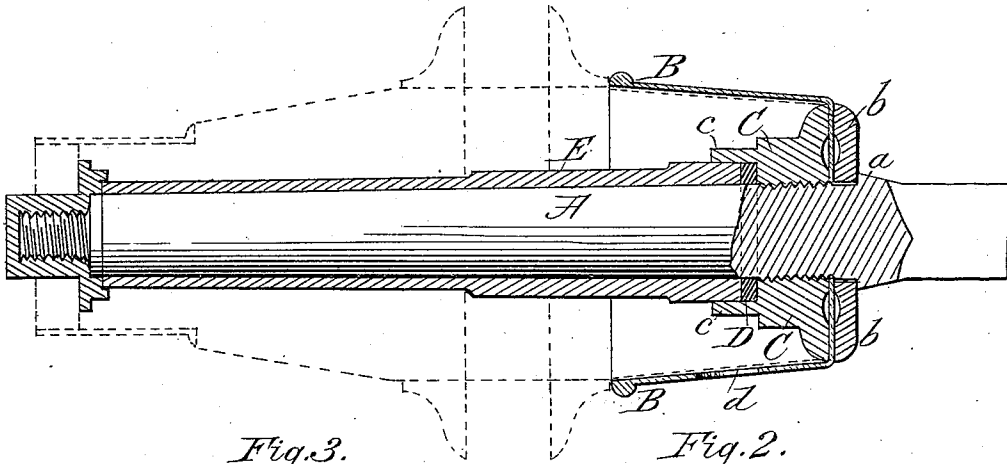

Fig. 3.

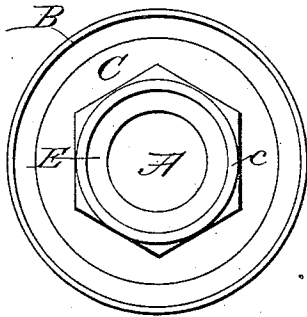

Fig. 2.

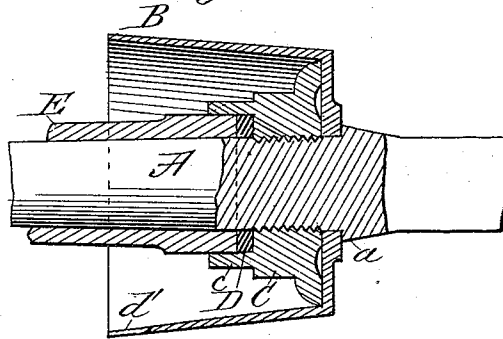

Fig. 4.

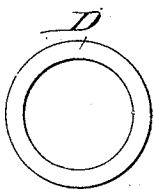

Fig. 5.

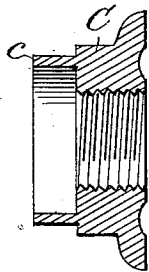

Fig. 6.

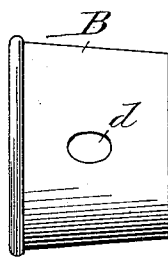
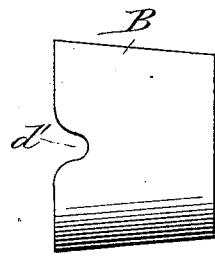

Fig. 7.



Attest:

A. H. Schott  
A. R. Brown.

Inventor:

Frank S. Rolfe,  
Chas. J. C. Foster atty.

F. S. ROLFE.  
SAND BAND FOR VEHICLES.

No. 304,239.

Patented Aug. 26, 1884.

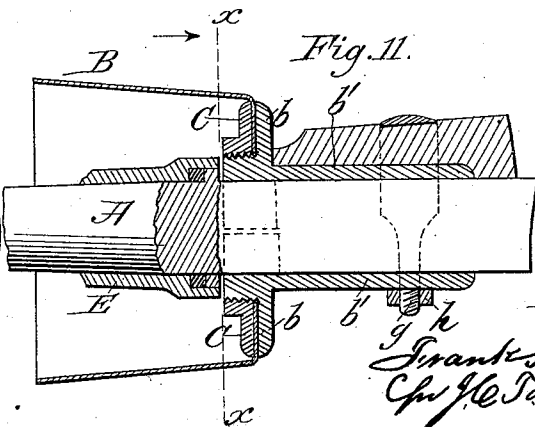
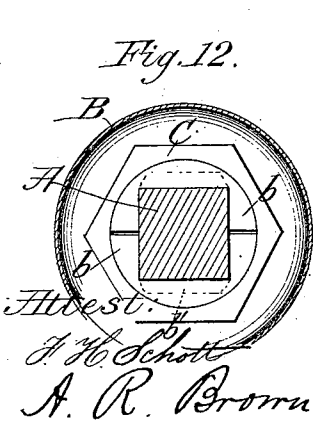
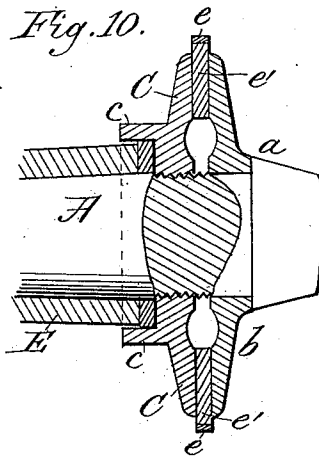
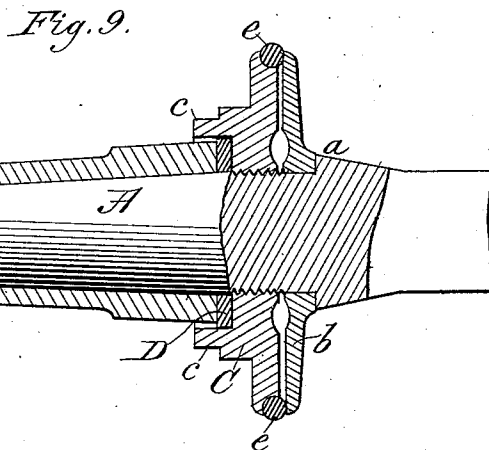
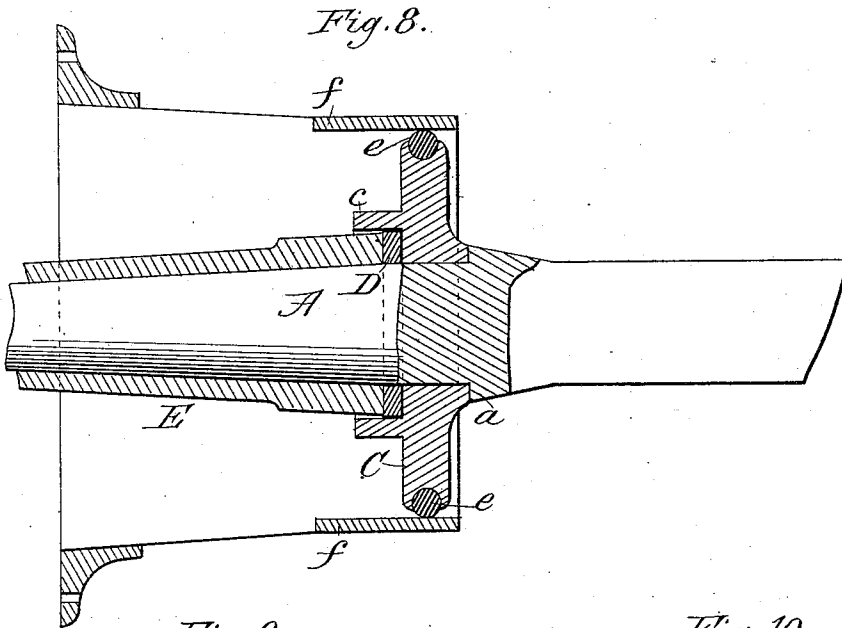

Inventor:  
Frank S. Rolfe  
Chas. C. Pascoe atty

# UNITED STATES PATENT OFFICE.

FRANK S. ROLFE, OF WATERBURY, VERMONT.

## SAND-BAND FOR VEHICLES.

SPECIFICATION forming part of Letters Patent No. 304,239, dated August 26, 1884.

Application filed April 18, 1884. (No model.)

*To all whom it may concern:*

Be it known that I, FRANK S. ROLFE, a citizen of the United States, residing at Waterbury, in the county of Washington and State of Vermont, have invented certain new and useful Improvements in Sand-Bands for Vehicle-Axles; and I do hereby declare the following to be a full, clear, and exact description of the invention, such as will enable others skilled in the art to which it appertains to make and use the same, reference being had to the accompanying drawings, and to the letters and figures of reference marked thereon, which form a part of this specification.

This invention has relation to certain improvements in sand bands or boxes for vehicle-axles; and it consists in the construction and arrangement of parts, as hereinafter more fully described and claimed.

In the annexed drawings illustrating the invention, Figure 1 is a sectional side elevation of one form of my improved sand-band, showing the parts in position. Fig. 2 is a sectional side view illustrating a modification. Fig. 3 is an inner end view of the sand-band and connections shown in Fig. 2. Figs. 4 to 7 illustrate various details of construction, and Figs. 8 to 12 represent further modifications.

Like letters designate like parts.

The axle-spindle A is made with a shoulder, *a*, that affords a bearing for the inner end of the sand-band and connections. The sand-band B may abut directly against this shoulder, as shown in Fig. 2; or, in the case of a spur-band, as shown in Fig. 1, a disk, *b*, is interposed between the sand-bands and the shoulder. The sand-band is secured upon the axle-spindle by means of a hexagon-faced nut, C, that is screwed upon the threaded portion of the spindle within the sand-band, as shown in Figs. 1 and 2. A washer, D, of leather, rubber, or other suitable material, is placed on the axle-spindle beneath or within an annular projection, *e*, that is formed on the nut C. This projection or annulus *e* also covers the inner end of the axle-box E, which abuts against the washer D, as shown. The band or box B has a sand and oil hole, *d*, or notch *d'*, in its under side, as usual.

In Fig. 8 the ordinary sand band or box is dispensed with, and the nut C is made to bear directly against the shoulder *a* of the axle-spindle. In this case the nut C is provided,

as before described, with an annular projection, *e*, that covers the washer D and the end of the axle-box. It has also a grooved periphery, in which is fitted an annular packing, *e*, of elastic material, that bears within and against the back-band *f* of the hub. The nut C, with its annular packing *e*, thus fills the inner end of the hub, and prevents the entrance of grit and sand at the same time that the band *e* by its elasticity obviates rattling.

Instead of securing the nut C in contact with the shoulder *a*, the disk *b* may be interposed and the packing *e* be clamped between the nut and disk, as shown in Figs. 9 and 10. Any suitable packing can be employed, either round, as shown in Figs. 8 and 9, or flat annular bands, as seen in Fig. 10, and in the latter case a leather packing-ring, *e'*, and a rubber ring, *e*, can be used together, one within the other, if desired. The sand-band will be firmly secured between the nut C and disk *b*, so as to prevent the entrance of grit, and the packing *e e'* will effectually prevent rattling.

If desired, the parts may be arranged as shown in Figs. 11 and 12, in which the disk *b* is formed in two parts, with a boxing, *b'*, to fit the square part of the axle, to which it is secured by an axle-clip, *g*, and nut *h*. In this case the sand-band is secured between the nut C and two-part disk.

Having thus described my invention, what I claim as new, and desire to secure by Letters Patent, is—

1. The combination of the axle-spindle A, having shoulder *a*, the axle-box E, washer D, nut C, having an internal annular projection or collar, *e*, and the packing-ring *e*, adapted to bear within the back plate of the hub, substantially as described.

2. The combination of the axle-spindle A, provided with shoulder *a*, the disk *b*, the nut C, having an internal annular projection, *e*, a suitable packing clamped between said nut and disk, the axle-box E, and the washer D, substantially as described.

In testimony whereof I affix my signature in presence of two witnesses.

FRANK S. ROLFE.

Witnesses:

GEO. W. WING,  
JOHN G. WING.