



(19) **United States**

(12) **Patent Application Publication**

KUMAKURA et al.

(10) **Pub. No.: US 2020/0309437 A1**

(43) **Pub. Date: Oct. 1, 2020**

(54) **REFRIGERATION CYCLE APPARATUS AND METHOD OF DETERMINING REFRIGERANT ENCLOSURE AMOUNT IN REFRIGERATION CYCLE APPARATUS**

Dec. 18, 2017	(JP)	2017-242187
Oct. 5, 2018	(JP)	PCT/JP2018/037483
Oct. 17, 2018	(JP)	PCT/JP2018/038746
Oct. 17, 2018	(JP)	PCT/JP2018/038747
Oct. 17, 2018	(JP)	PCT/JP2018/038748
Oct. 17, 2018	(JP)	PCT/JP2018/038749

(71) Applicant: **DAIKIN INDUSTRIES, LTD.**, Osaka (JP)

Publication Classification

(72) Inventors: **Eiji KUMAKURA**, Osaka (JP); **Takuro YAMADA**, Osaka (JP); **Atsushi YOSHIMI**, Osaka (JP); **Ikuhiro IWATA**, Osaka (JP); **Mitsushi ITANO**, Osaka (JP); **Daisuke KARUBE**, Osaka (JP); **Yuuki YOTSUMOTO**, Osaka (JP); **Kazuhiro TAKAHASHI**, Osaka (JP); **Yuzo KOMATSU**, Osaka (JP); **Shun OHKUBO**, Osaka (JP); **Tatsuya TAKAKUWA**, Osaka (JP)

(51) **Int. Cl.**
F25B 49/02 (2006.01)
F25B 31/00 (2006.01)
F25B 29/00 (2006.01)
F25B 41/00 (2006.01)

(52) **U.S. Cl.**
 CPC *F25B 49/022* (2013.01); *F25B 31/002* (2013.01); *F25B 40/06* (2013.01); *F25B 31/006* (2013.01); *F25B 41/003* (2013.01); *F25B 29/003* (2013.01)

(73) Assignee: **DAIKIN INDUSTRIES, LTD.**, Osaka (JP)

(57) **ABSTRACT**

A refrigeration cycle apparatus capable of keeping a LCCP low when a heat cycle is performed using a sufficiently small-GWP refrigerant, and a method of determining a refrigerant enclosure amount in the refrigeration cycle apparatus are provided. An outdoor unit (20) including a compressor (21) and an outdoor heat exchanger (23), an indoor unit (30) including an indoor heat exchanger (31), and a refrigerant pipe (5, 6) that connects the outdoor unit (20) and the indoor unit (30) to each other are provided. A refrigerant containing at least 1,2-difluoroethylene is enclosed in a refrigerant circuit (10) that is constituted by connecting the compressor (21), the outdoor heat exchanger (23), and the indoor heat exchanger (31) to one another. An enclosure amount of the refrigerant in the refrigerant circuit (10) per 1 kW of refrigeration capacity satisfies a condition of 160 g or more and 560 g or less.

(21) Appl. No.: **16/954,613**

(22) PCT Filed: **Dec. 10, 2018**

(86) PCT No.: **PCT/JP2018/045289**

§ 371 (c)(1),

(2) Date: **Jun. 17, 2020**

(30) **Foreign Application Priority Data**

Dec. 18, 2017	(JP)	2017-242183
Dec. 18, 2017	(JP)	2017-242185
Dec. 18, 2017	(JP)	2017-242186

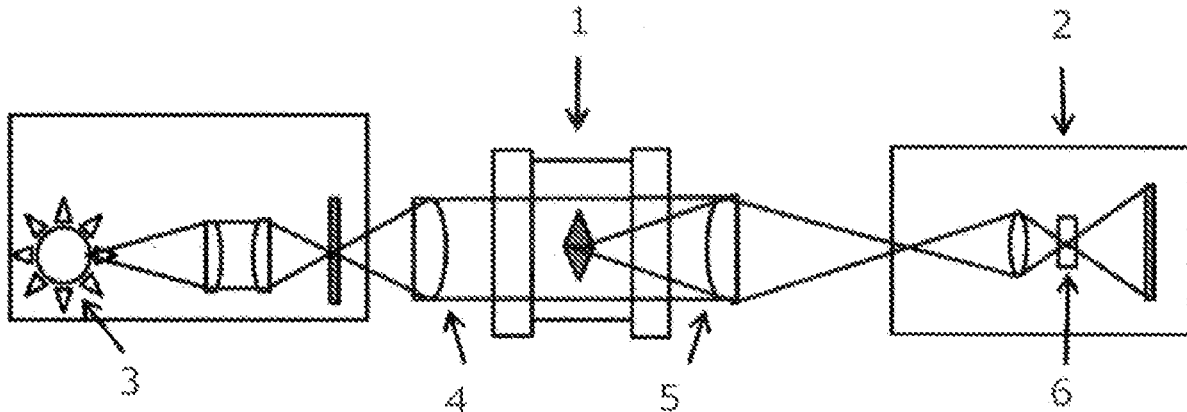

Fig. 1

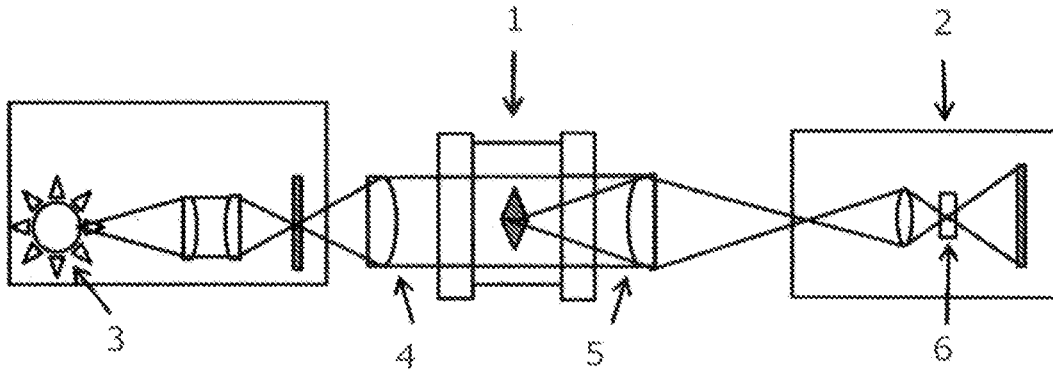

Fig. 2

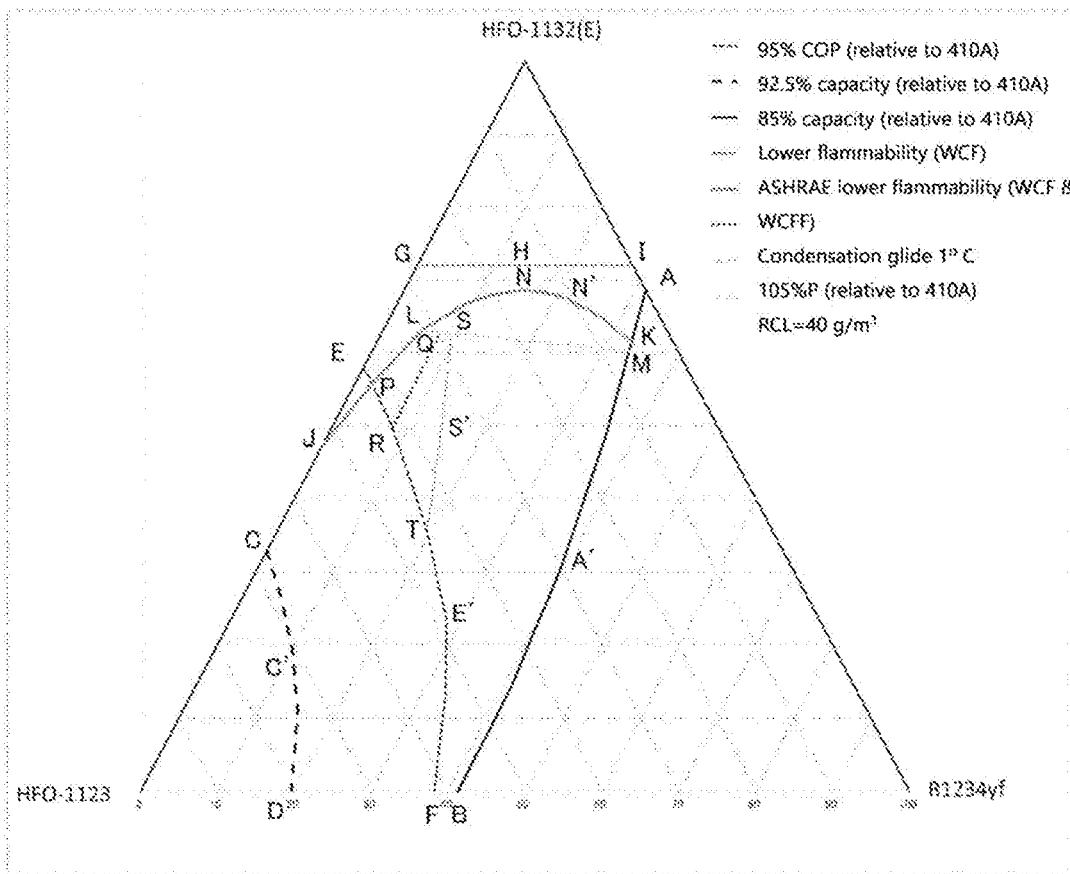

Fig.3

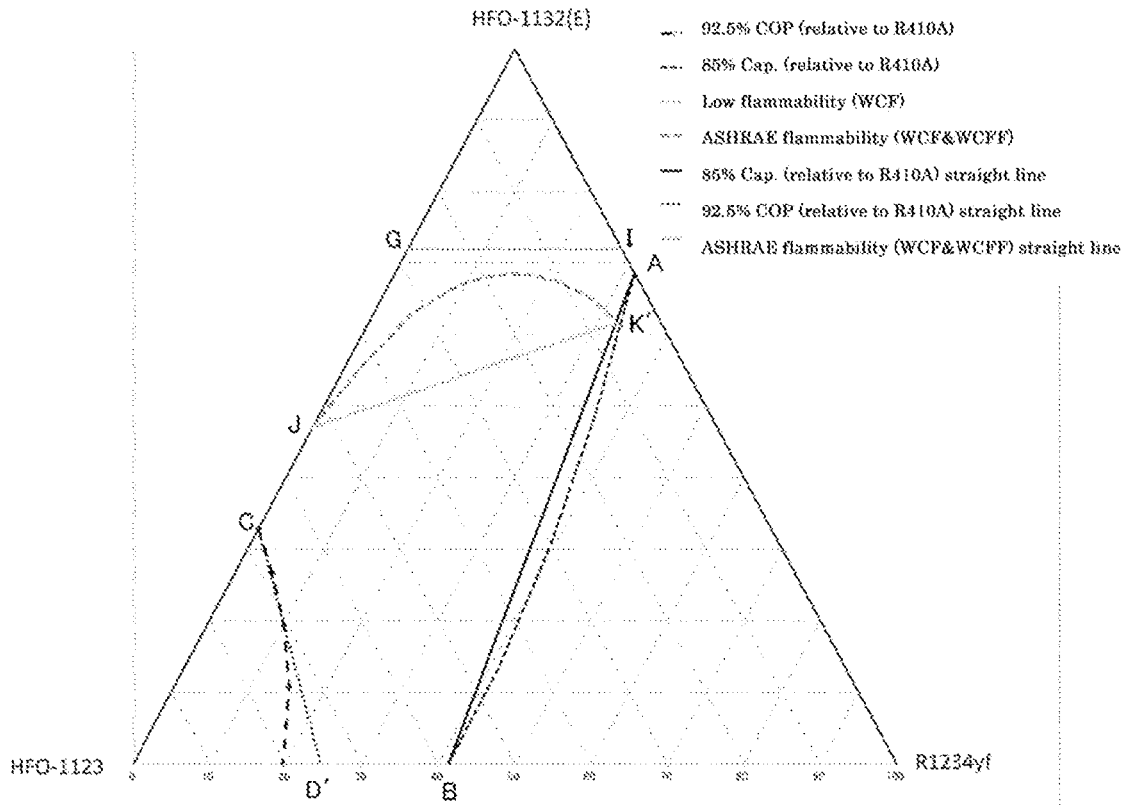

Fig. 4

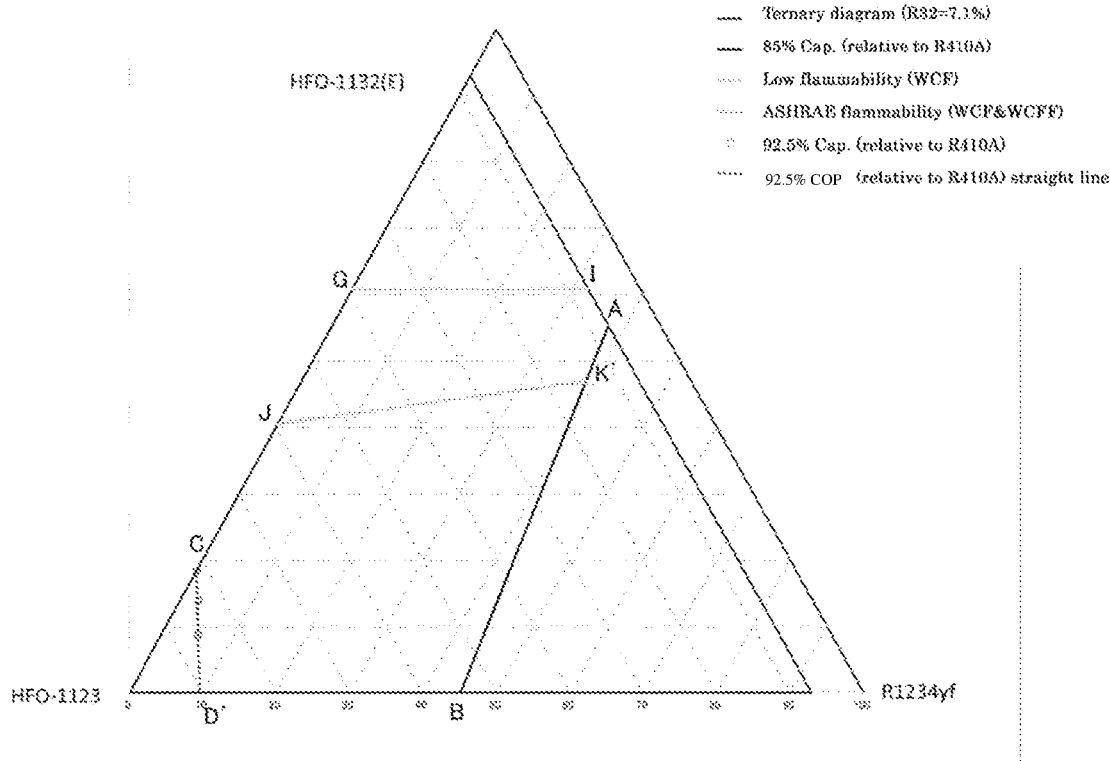

Fig. 5

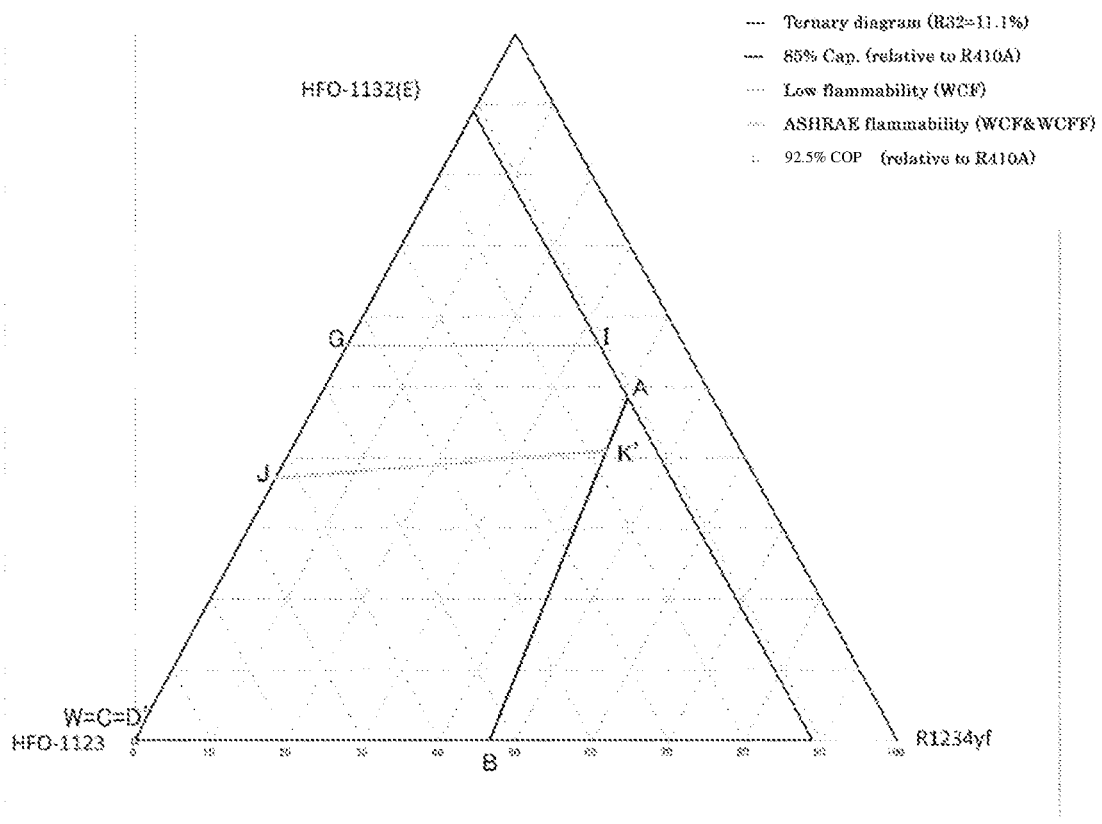

Fig. 6

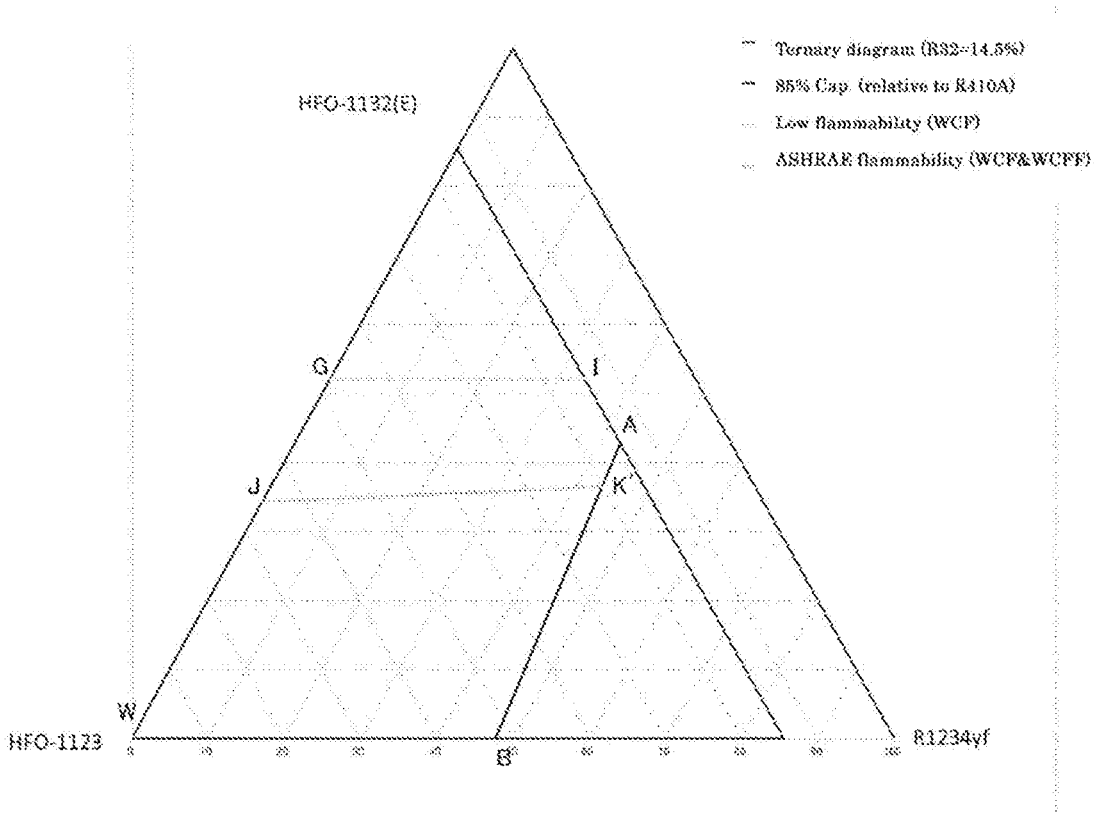

Fig. 7

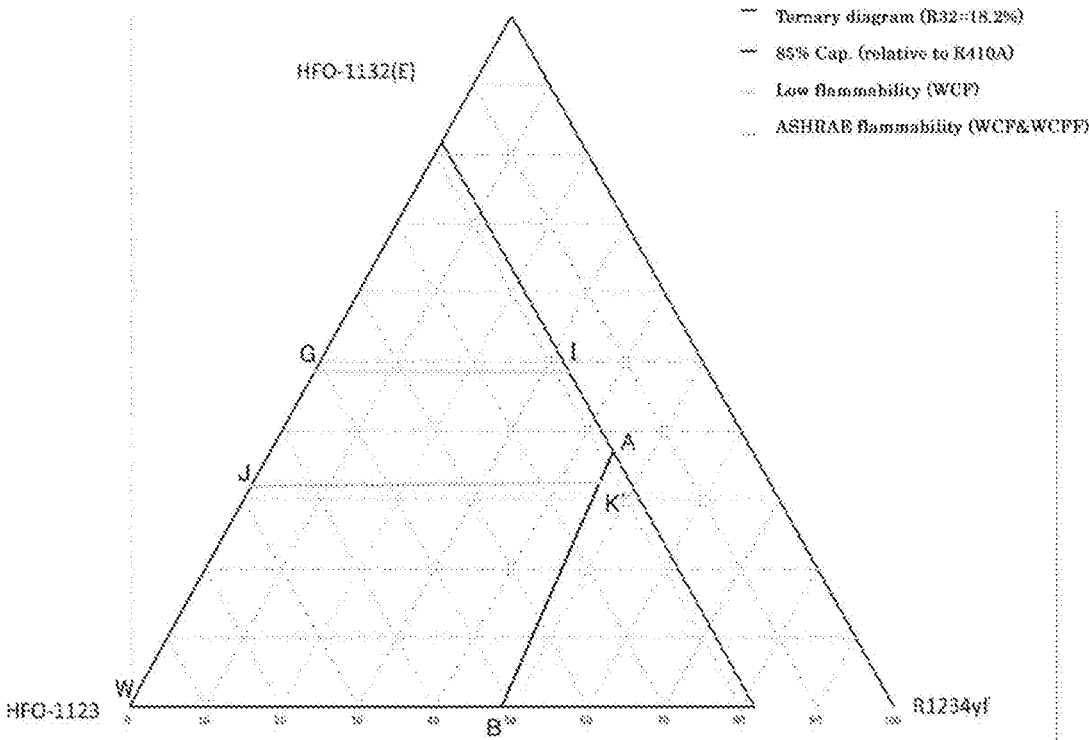

Fig. 8

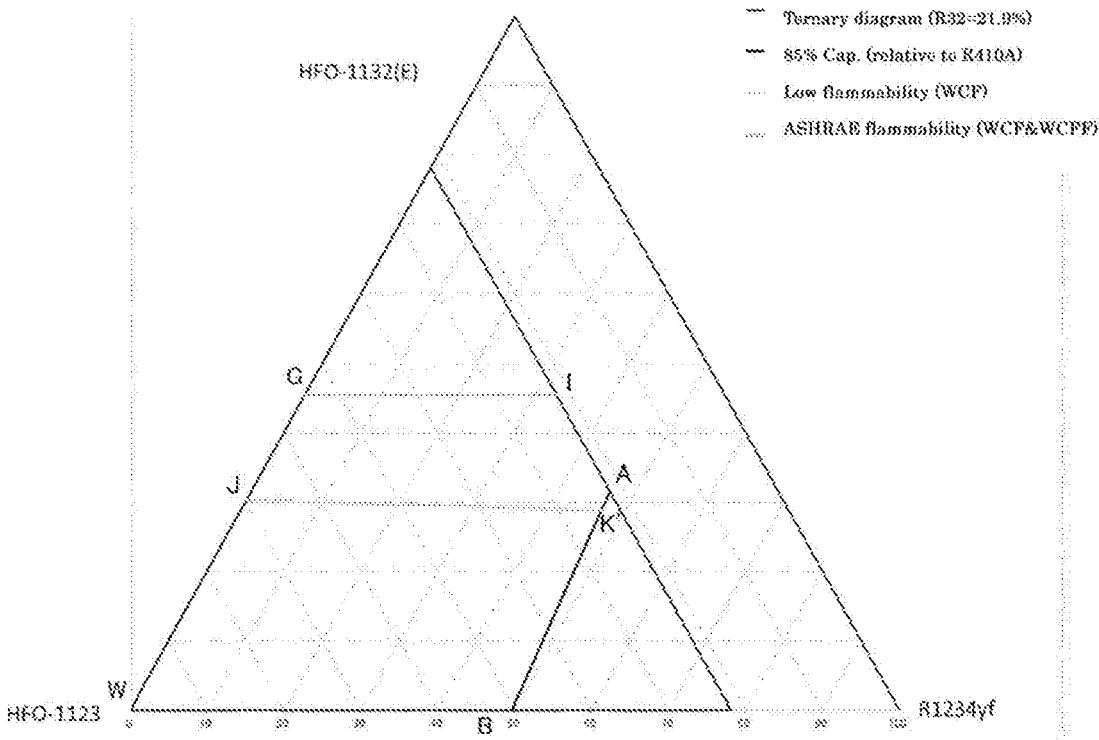

Fig. 9

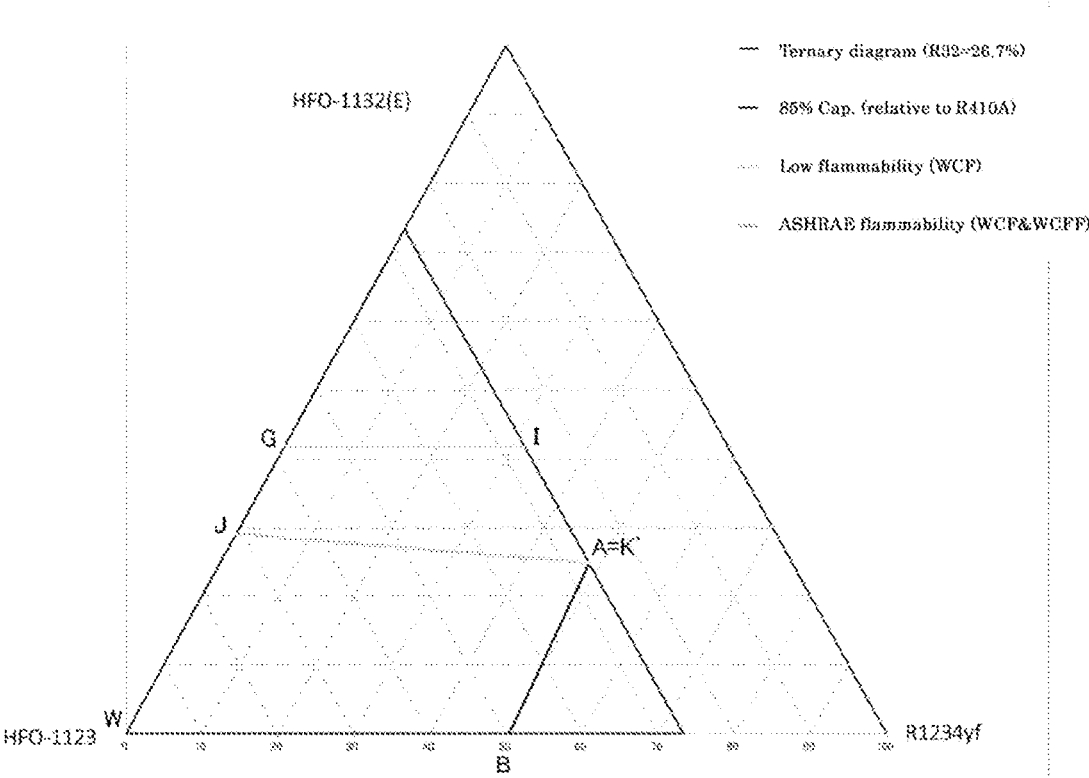

Fig. 10

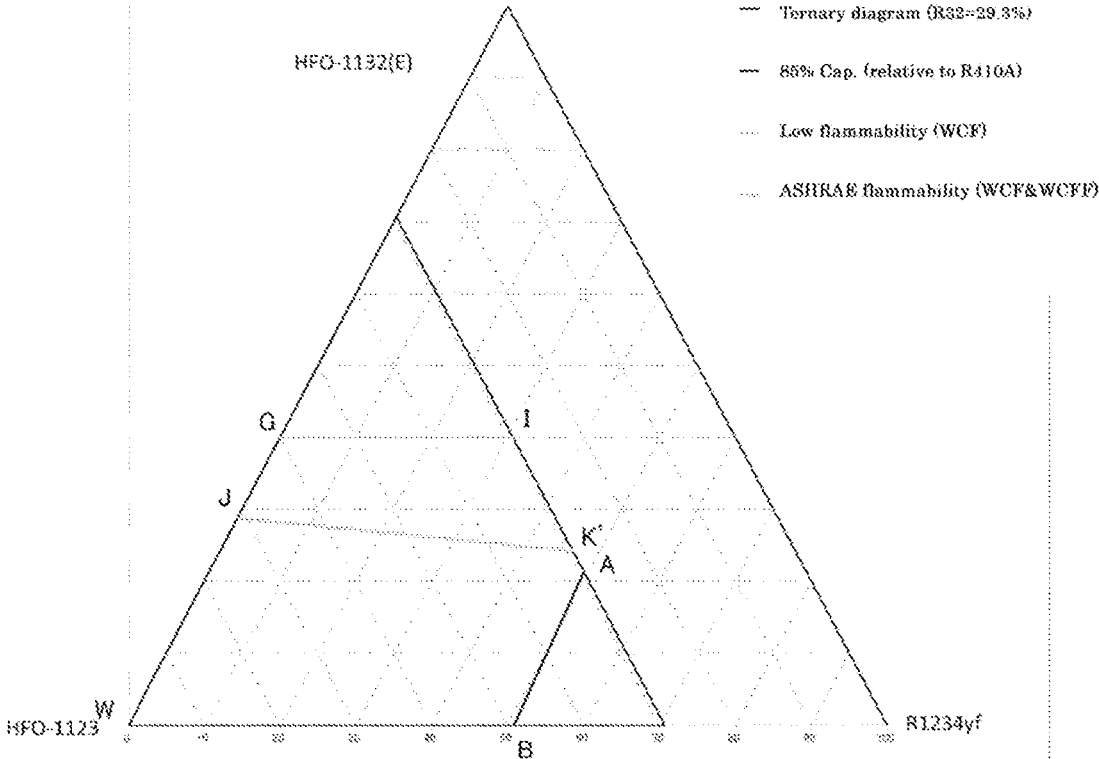

Fig. 11

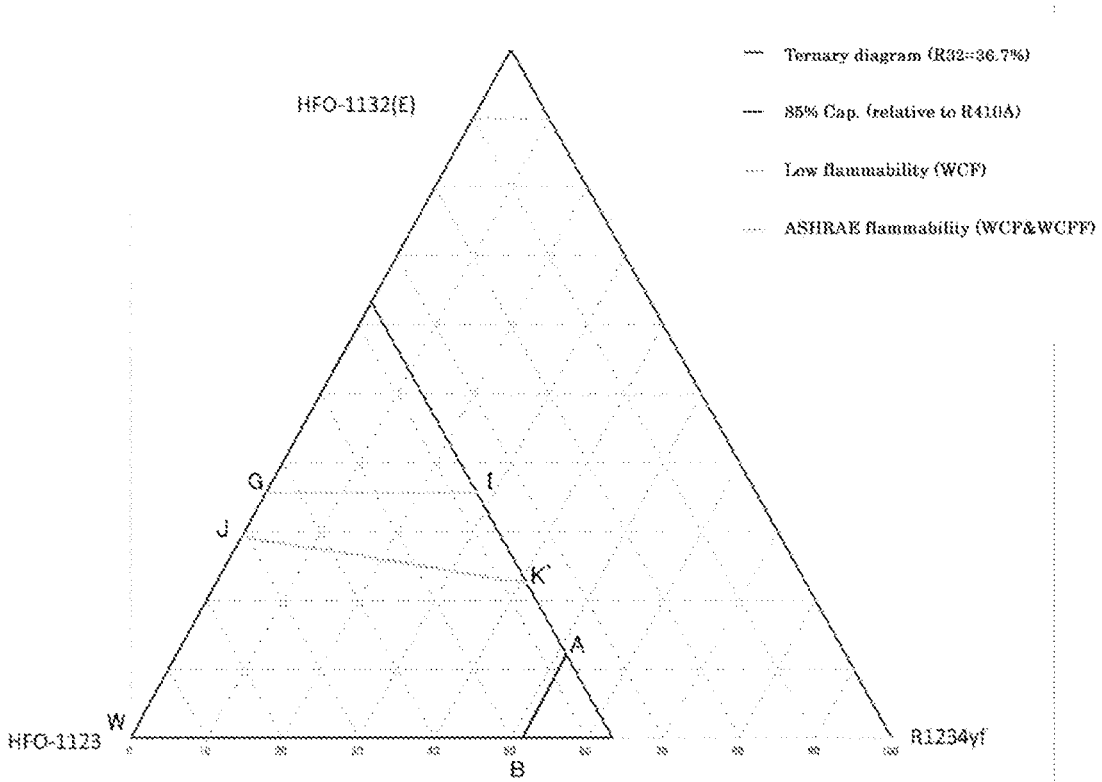

Fig. 12

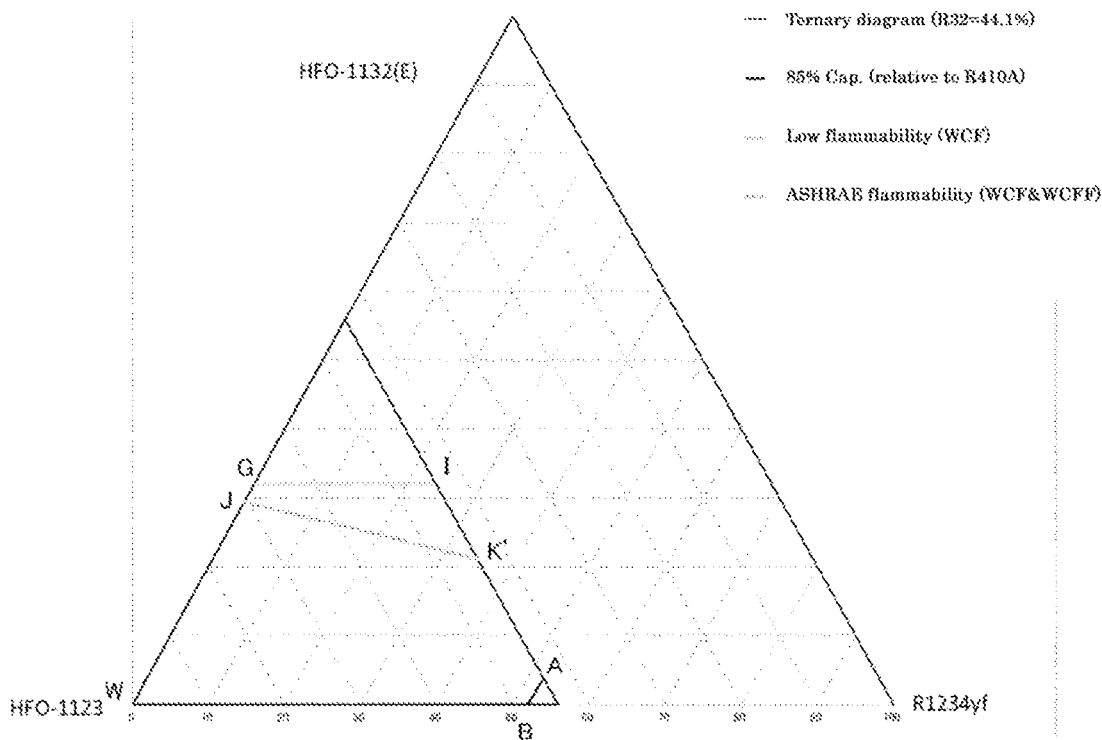

Fig. 13

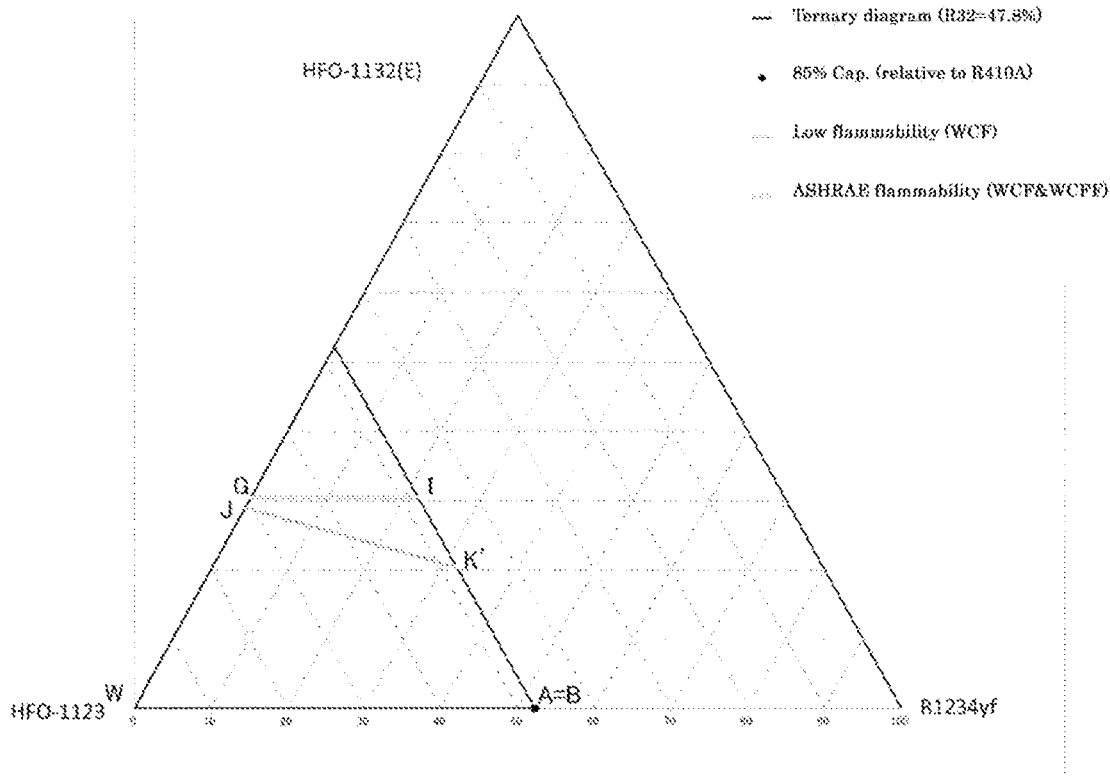

Fig. 14

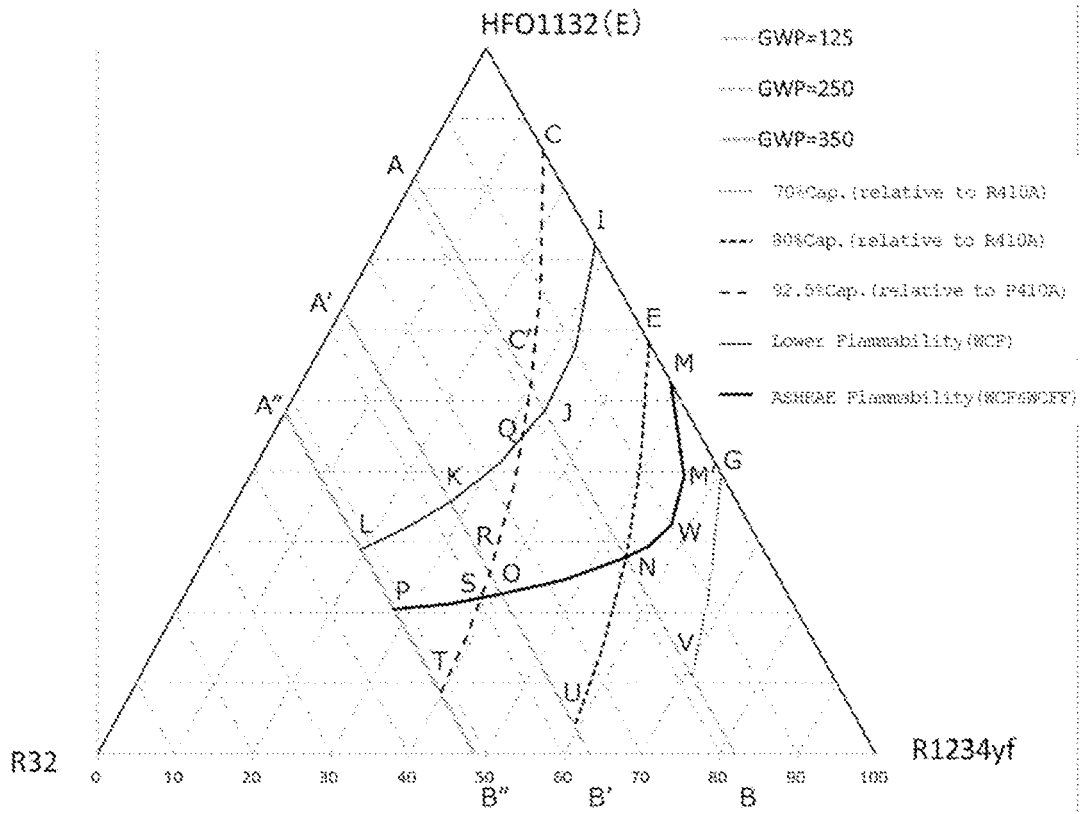
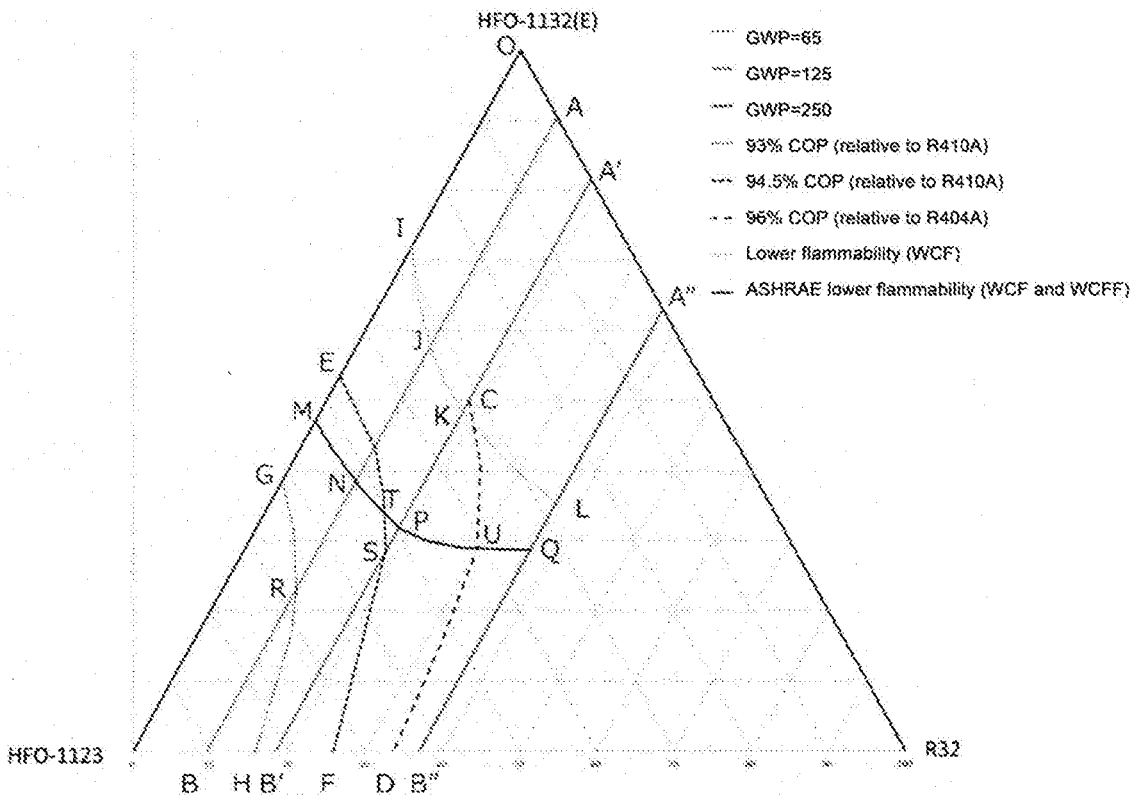

Fig. 15



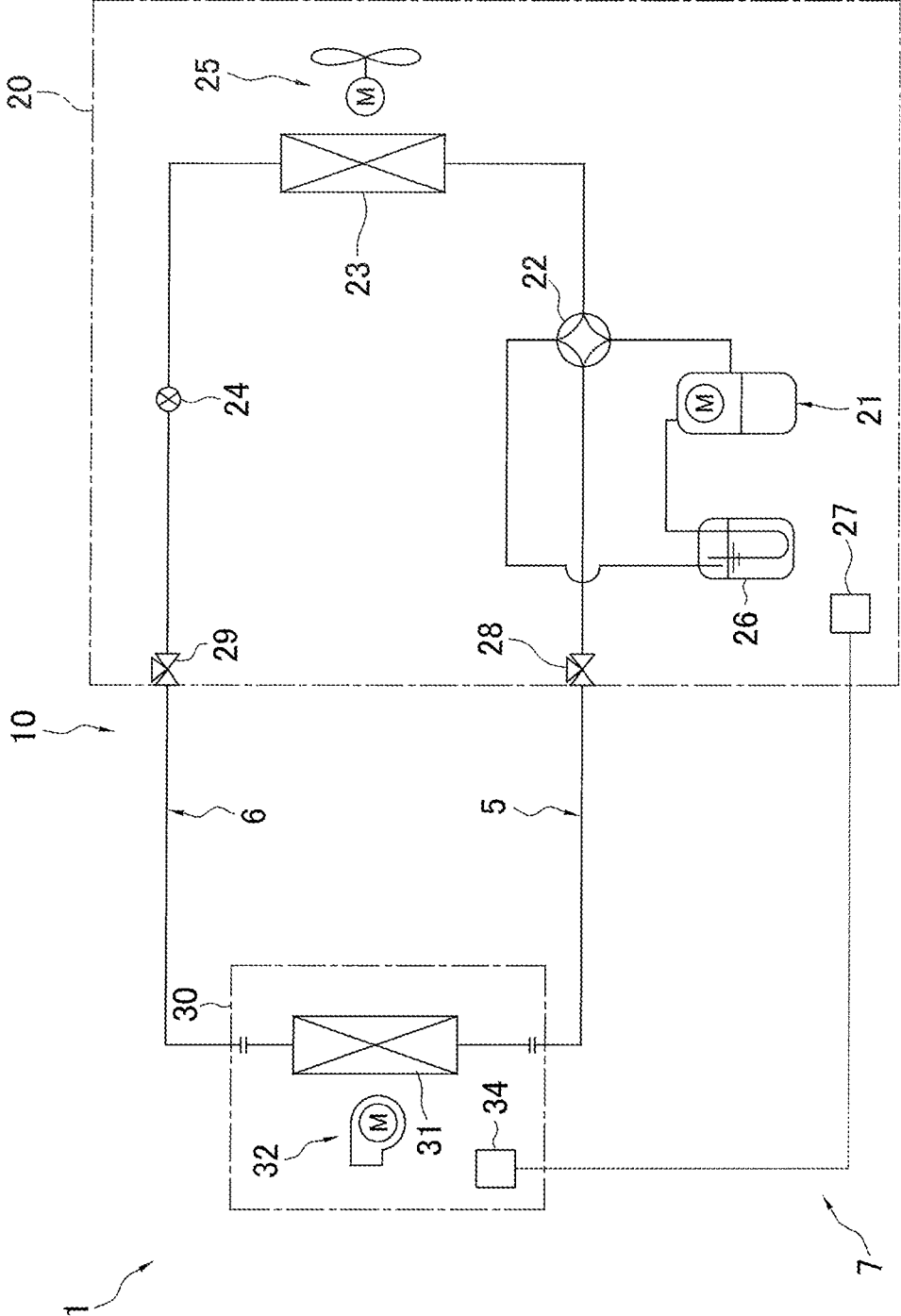

FIG. 16

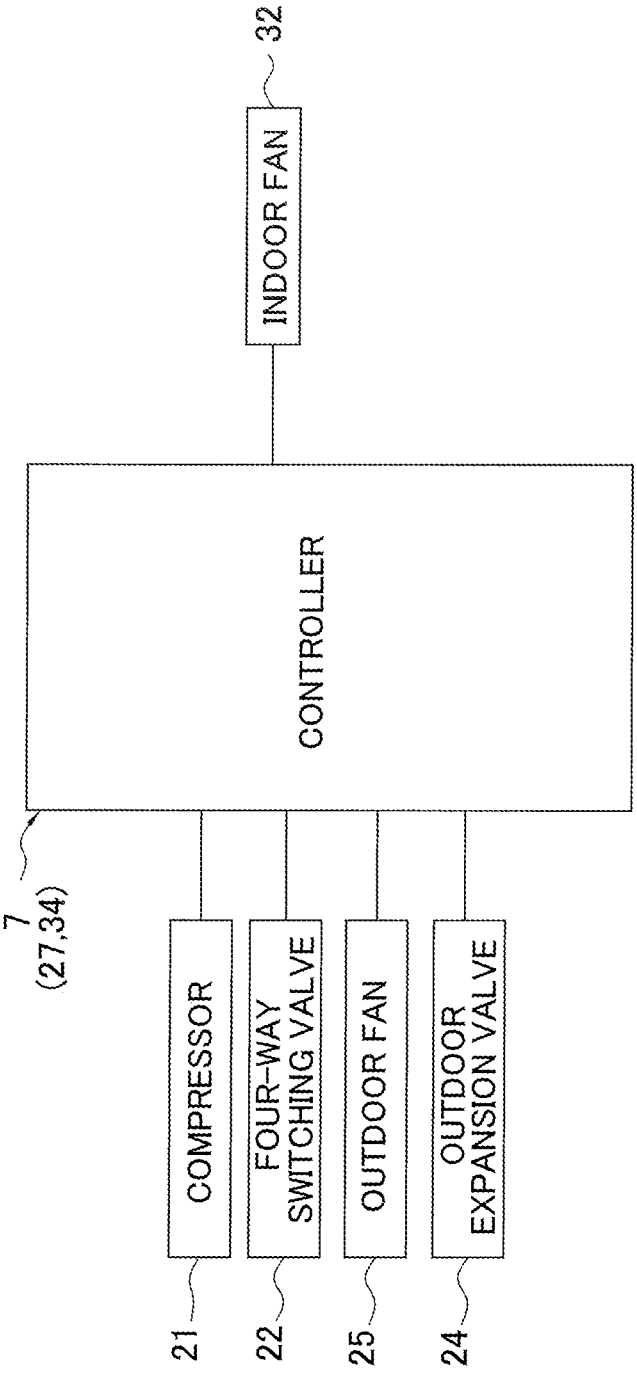

FIG. 17

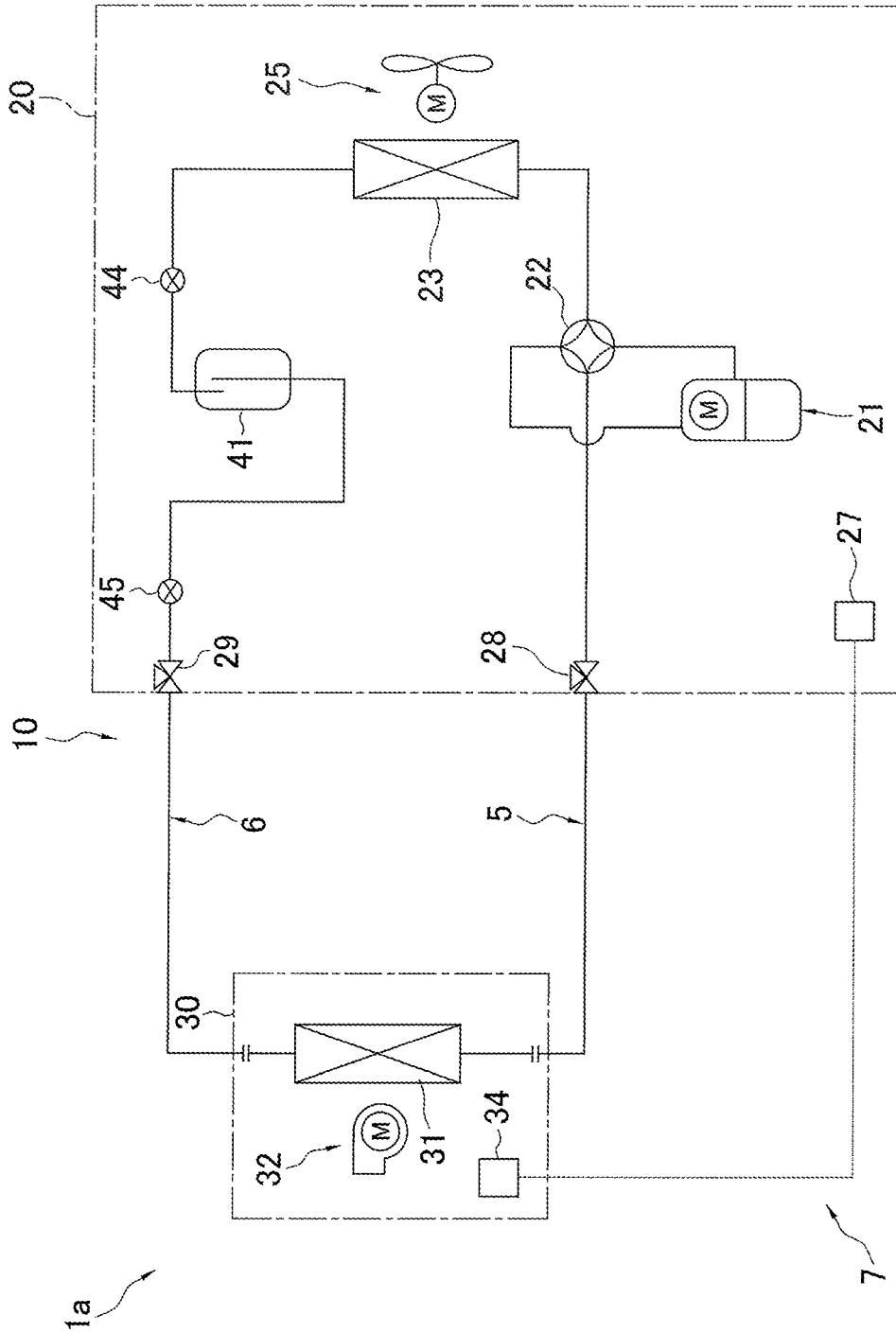

FIG. 18

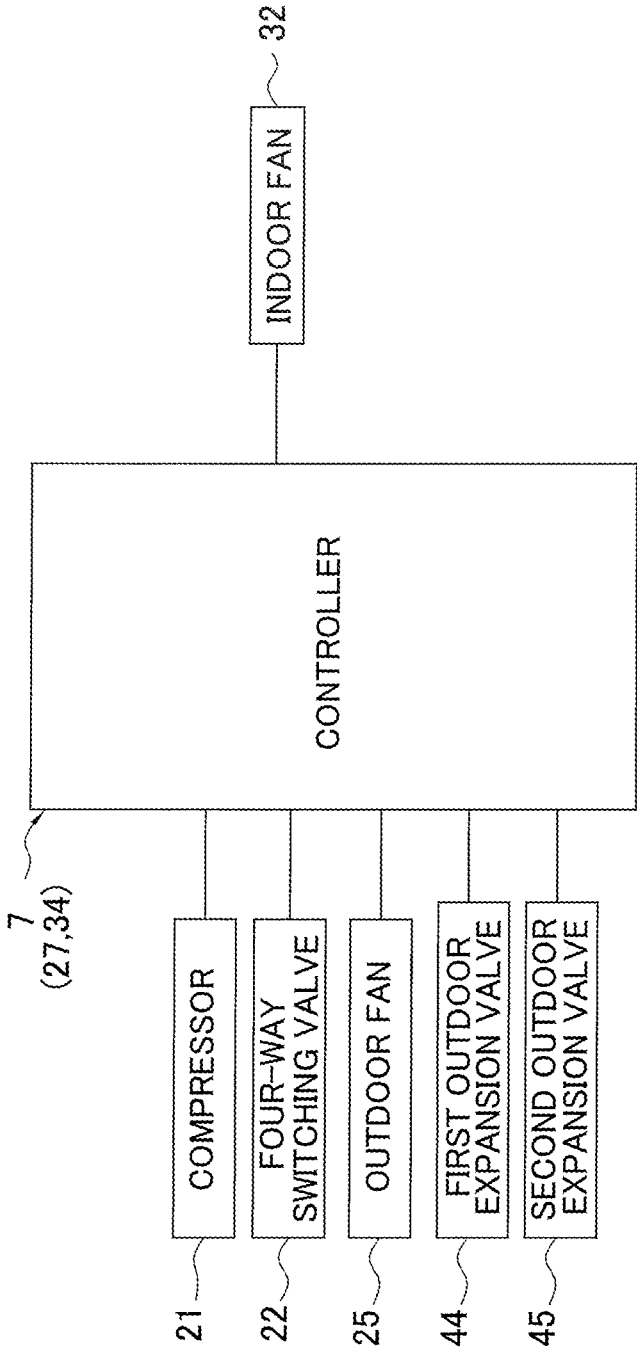

FIG. 19

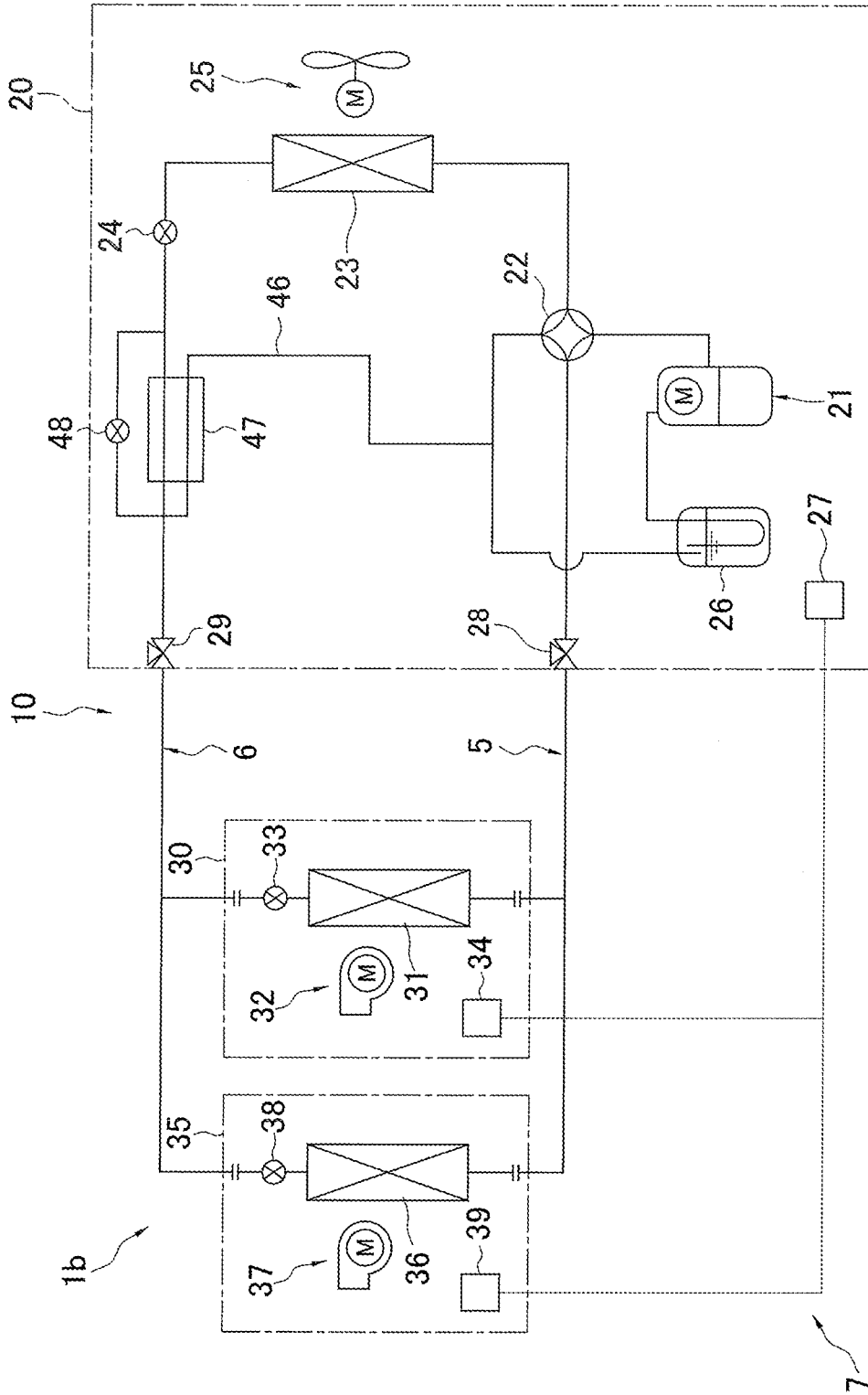

FIG. 20

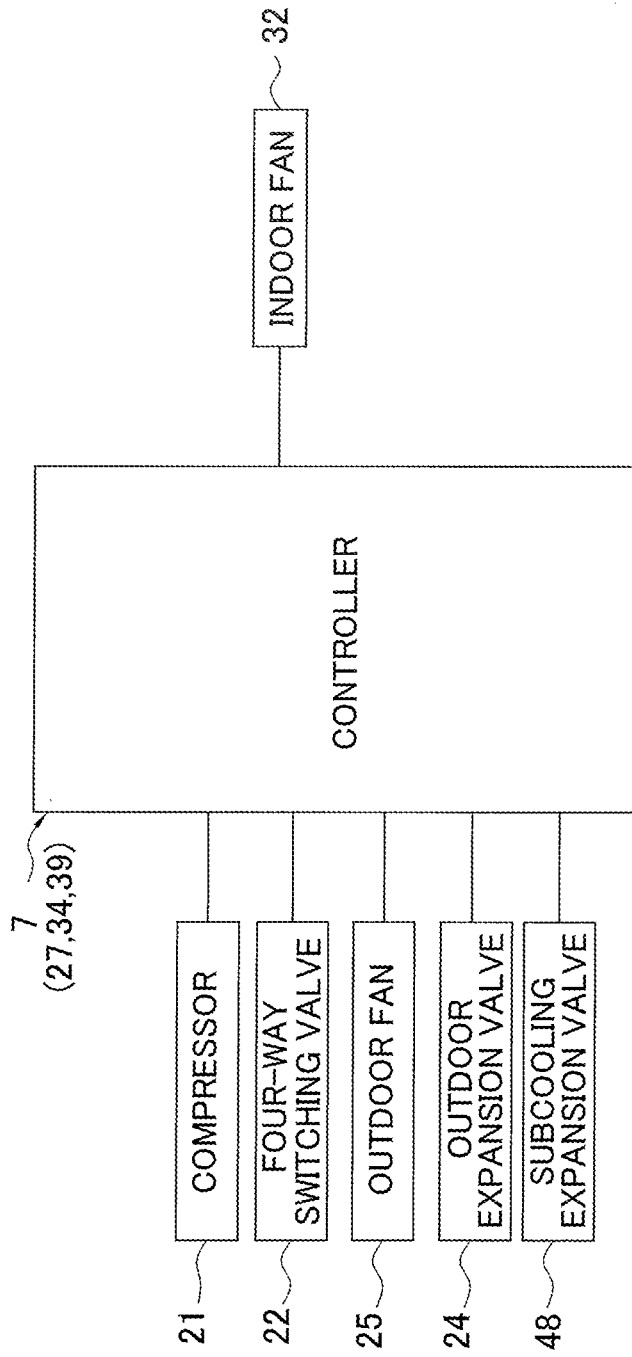

FIG. 21

**REFRIGERATION CYCLE APPARATUS AND
METHOD OF DETERMINING
REFRIGERANT ENCLOSURE AMOUNT IN
REFRIGERATION CYCLE APPARATUS**

TECHNICAL FIELD

[0001] The present disclosure relates to a refrigeration cycle apparatus and a method of determining a refrigerant enclosure amount in the refrigeration cycle apparatus.

BACKGROUND ART

[0002] Conventionally, heat cycle systems such as air conditioning apparatuses frequently use R410A as a refrigerant. R410A is a two-component mixed refrigerant of difluoromethane (CH_2F_2 ; HFC-32 or R32) and pentafluoroethane (C_2HF_5 ; HFC-125 or R125), and is a pseudo-azeotropic composition.

[0003] However, R410A has a global warming potential (GWP) of 2088. In recent years, R32 which is a refrigerant having a lower GWP of 675 is being more used as a result of growing concern about global warming.

[0004] Due to this, for example, PTL 1 (International Publication No. 2015/141678) suggests various low-GWP mixed refrigerants alternative to R410A.

SUMMARY OF THE INVENTION

Technical Problem

[0005] An example of an index concerning prevention of global warming may be an index called life cycle climate performance (LCCP). The LCCP is an index concerning prevention of global warming, and is a numerical value obtained by adding an energy consumption when greenhouse effect gases to be used are manufactured (indirect impact) and a leakage to the outside air (direct impact) to a total equivalent warming impact (TEWI). The unit of the LCCP is kg-CO_2 . That is, the TEWI is obtained by adding a direct impact and an indirect impact calculated using respective predetermined mathematical expressions. The LCCP is calculated using the following relational expression.

$$\text{LCCP} = \text{GWPRM} \times W + \text{GWP} \times W \times (1 - R) + N \times Q \times A$$

[0006] In the expression, GWPRM is a warming effect relating to manufacturing of a refrigerant, W is a refrigerant filling amount, R is a refrigerant recovery amount when an apparatus is scrapped, N is a duration of using the apparatus (year), Q is an emission intensity of CO_2 , and A is an annual power consumption.

[0007] Regarding the LCCP of the refrigeration cycle apparatus, when the filling amount in the refrigerant circuit is too small, an insufficiency of the refrigerant decreases cycle efficiency, resulting in an increase in the LCCP; and when the filling amount in the refrigerant circuit is too large, the impact of the GWP increases, resulting in an increase in the LCCP. Moreover, a refrigerant having a lower GWP than R32 which has been frequently used tends to have a low heat-transfer capacity, and tends to have a large LCCP as the result of the decrease in cycle efficiency.

[0008] The content of the present disclosure aims at the above-described point and an object of the present disclosure is to provide a refrigeration cycle apparatus capable of keeping a LCCP low when a heat cycle is performed using

a sufficiently small-GWP refrigerant, and a method of determining a refrigerant enclosure amount in the refrigeration cycle apparatus.

Solution to Problem

[0009] A refrigeration cycle apparatus according to a first aspect includes a heat source unit, a service unit, and a refrigerant pipe. The heat source unit includes a compressor and a heat-source-side heat exchanger. The service unit includes a service-side heat exchanger. The refrigerant pipe connects the heat source unit and the service unit to each other. A refrigerant containing at least 1,2-difluoroethylene is enclosed in a refrigerant circuit that is constituted by connecting the compressor, the heat-source-side heat exchanger, and the service-side heat exchanger to one another. An enclosure amount of the refrigerant in the refrigerant circuit satisfies a condition of 160 g or more and 560 g or less per 1 kW of refrigeration capacity of the refrigeration cycle apparatus.

[0010] Note that the refrigeration capacity of the refrigeration cycle apparatus represents a rated refrigeration capacity.

[0011] Since the refrigerant containing at least 1,2-difluoroethylene is enclosed in the refrigerant circuit by an amount of 160 g or more and 560 g or less per 1 kW of refrigeration capacity, when the refrigeration cycle apparatus performs a heat cycle using a refrigerant with a sufficiently small GWP, the LCCP can be kept low.

[0012] Note that, for the inner capacity (the volume of a fluid with which the inside can be filled) of the heat-source-side heat exchanger, when the refrigerant circuit is not provided with a refrigerant container (for example, a low-pressure receiver or a high-pressure receiver, excluding an accumulator belonging to a compressor), the inner capacity is preferably 0.4 L or more and 2.5 L or less. When the refrigerant circuit is provided with a refrigerant container, the inner capacity is preferably 1.4 L or more and less than 5.0 L.

[0013] Moreover, for the inner capacity (the volume of a fluid with which the inside can be filled) of the heat-source-side heat exchanger included in the heat source unit provided with only one fan, when the heat source unit has a casing having a blow-out port for blowing out the air which has passed through the heat-source-side heat exchanger in a side surface in an installed state (when the heat source unit is trunk type or the like), the inner capacity is preferably 0.4 L or more and less than 3.5 L. For the inner capacity (the volume of a fluid with which the inside can be filled) of the heat-source-side heat exchanger included in the heat source unit provided with two fans, when the heat source unit has a casing having a blow-out port for blowing out the air which has passed through the heat-source-side heat exchanger in a side surface in an installed state (when the heat source unit is trunk type or the like), the inner capacity is preferably 3.5 L or more and less than 5.0 L.

[0014] A refrigeration cycle apparatus according to a second aspect includes a heat source unit, a first service unit, a second service unit, and a refrigerant pipe. The heat source unit includes a compressor and a heat-source-side heat exchanger. The first service unit includes a first service-side heat exchanger. The second service unit includes a second service-side heat exchanger. The refrigerant pipe connects the heat source unit, the first service unit, and the second service unit to one another. A refrigerant containing at least

1,2-difluoroethylene is enclosed in a refrigerant circuit that is constituted by connecting the first service-side heat exchanger and the second service-side heat exchanger in parallel to the compressor and the heat-source-side heat exchanger. An enclosure amount of the refrigerant in the refrigerant circuit per 1 kW of refrigeration capacity satisfies a condition of 190 g or more and 1660 g or less.

[0015] Since the refrigerant containing at least 1,2-difluoroethylene is enclosed in the refrigerant circuit including the plurality of service-side heat exchangers connected in parallel to each other, by an amount of 190 g or more and 1660 g or less per 1 kW of refrigeration capacity, when the refrigeration cycle apparatus performs a heat cycle using a refrigerant with a sufficiently small GWP, the LCCP can be kept low.

[0016] Note that, for the inner capacity (the volume of a fluid with which the inside can be filled) of the heat-source-side heat exchanger, when the first service unit does not have an expansion valve on the liquid side of the first service-side heat exchanger and the second service unit also does not have an expansion valve on the liquid side of the second service-side heat exchanger, the inner capacity is preferably 1.4 L or more and less than 5.0 L. When the first service unit has an expansion valve on the liquid side of the first service-side heat exchanger and the second service unit also has an expansion valve on the liquid side of the second service-side heat exchanger, the inner capacity is preferably 5.0 L or more and 38 L or less.

[0017] Moreover, for the inner capacity (the volume of a fluid with which the inside can be filled) of the heat-source-side heat exchanger included in the heat source unit provided with only one fan, when the heat source unit has a casing having a blow-out port for blowing out the air which has passed through the heat-source-side heat exchanger in a side surface in an installed state (when the heat source unit is trunk type or the like), the inner capacity is preferably 0.4 L or more and less than 3.5 L. For the inner capacity (the volume of a fluid with which the inside can be filled) of the heat-source-side heat exchanger included in the heat source unit provided with two fans, when the heat source unit has a casing having a blow-out port for blowing out the air which has passed through the heat-source-side heat exchanger in a side surface in an installed state (when the heat source unit is trunk type or the like), the inner capacity is preferably 3.5 L or more and 7.0 L or less. For the inner capacity (the volume of a fluid with which the inside can be filled) of the heat-source-side heat exchanger included in the heat source unit that blows out upward the air which has passed through the heat-source-side heat exchanger, the inner capacity is preferably 5.5 L or more and 38 L or less.

[0018] A refrigeration cycle apparatus according to a third aspect is the refrigeration cycle apparatus according to the first or second aspect, wherein

[0019] the refrigerant comprises trans-1,2-difluoroethylene (HFO-1132(E)), trifluoroethylene (HFO-1123), and 2,3,3,3-tetrafluoro-1-propene (R1234yf).

[0020] The refrigeration cycle apparatus can perform a refrigeration cycle using a refrigerant having properties including a sufficiently small GWP, and a refrigeration capacity (possibly referred to as cooling capacity or capacity) and a coefficient of performance (COP) equivalent to those of R410A.

[0021] A refrigeration cycle apparatus according to a fourth aspect is the refrigeration cycle apparatus according to the third aspect, wherein

[0022] when the mass % of HFO-1132(E), HFO-1123, and R1234yf based on their sum in the refrigerant is respectively represented by x, y, and z, coordinates (x,y,z) in a ternary composition diagram in which the sum of HFO-1132(E), HFO-1123, and R1234yf is 100 mass % are within the range of a figure surrounded by line segments AA', A'B, BD, DC', C'C, CO, and OA that connect the following 7 points:

point A (68.6, 0.0, 31.4),
point A' (30.6, 30.0, 39.4),
point B (0.0, 58.7, 41.3),
point D (0.0, 80.4, 19.6),
point C' (19.5, 70.5, 10.0),
point C (32.9, 67.1, 0.0), and
point O (100.0, 0.0, 0.0),

or on the above line segments (excluding the points on the line segments BD, CO, and OA);

[0023] the line segment AA' is represented by coordinates (x, $0.0016x^2 - 0.9473x + 57.497$, $-0.0016x^2 - 0.0527x + 42.503$),

[0024] the line segment A'B is represented by coordinates (x, $0.0029x^2 - 1.0268x + 58.7$, $-0.0029x^2 + 0.0268x + 41.3$),

[0025] the line segment DC' is represented by coordinates (x, $0.0082x^2 - 0.6671x + 80.4$, $-0.0082x^2 - 0.3329x + 19.6$),

[0026] the line segment C'C is represented by coordinates (x, $0.0067x^2 - 0.6034x + 79.729$, $-0.0067x^2 - 0.3966x + 20.271$), and

[0027] the line segments BD, CO, and OA are straight lines.

[0028] A refrigeration cycle apparatus according to a fifth aspect is the refrigeration cycle apparatus according to the third aspect, wherein

[0029] when the mass % of HFO-1132(E), HFO-1123, and R1234yf based on their sum in the refrigerant is respectively represented by x, y, and z, coordinates (x,y,z) in a ternary composition diagram in which the sum of HFO-1132(E), HFO-1123, and R1234yf is 100 mass % are within the range of a figure surrounded by line segments GI, IA, AA', A'B, BD, DC', C'C, and CG that connect the following 8 points:

point G (72.0, 28.0, 0.0),
point I (72.0, 0.0, 28.0),
point A (68.6, 0.0, 31.4),
point A' (30.6, 30.0, 39.4),
point B (0.0, 58.7, 41.3),
point D (0.0, 80.4, 19.6),
point C' (19.5, 70.5, 10.0), and
point C (32.9, 67.1, 0.0),

or on the above line segments (excluding the points on the line segments IA, BD, and CG);

[0030] the line segment AA' is represented by coordinates (x, $0.0016x^2 - 0.9473x + 57.497$, $-0.0016x^2 - 0.0527x + 42.503$),

[0031] the line segment A'B is represented by coordinates (x, $0.0029x^2 - 1.0268x + 58.7$, $-0.0029x^2 + 0.0268x + 41.3$),

[0032] the line segment DC' is represented by coordinates (x, $0.0082x^2 - 0.6671x + 80.4$, $-0.0082x^2 - 0.3329x + 19.6$),

[0033] the line segment C'C is represented by coordinates (x, $0.0067x^2 - 0.6034x + 79.729$, $-0.0067x^2 - 0.3966x + 20.271$), and

[0034] the line segments GI, IA, BD, and CG are straight lines.

[0035] A refrigeration cycle apparatus according to a sixth aspect is the refrigeration cycle apparatus according to the third aspect, wherein when the mass % of HFO-1132(E), HFO-1123, and R1234yf based on their sum in the refrigerant is respectively represented by x, y, and z, coordinates (x,y,z) in a ternary composition diagram in which the sum of HFO-1132(E), HFO-1123, and R1234yf is 100 mass % are within the range of a figure surrounded by line segments JP, PN, NK, KA', A'B, BD, DC', C'C, and CJ that connect the following 9 points:

point J (47.1, 52.9, 0.0),
 point P (55.8, 42.0, 2.2),
 point N (68.6, 16.3, 15.1),
 point K (61.3, 5.4, 33.3),
 point A' (30.6, 30.0, 39.4),
 point B (0.0, 58.7, 41.3),
 point D (0.0, 80.4, 19.6),
 point C' (19.5, 70.5, 10.0), and
 point C (32.9, 67.1, 0.0),

or on the above line segments (excluding the points on the line segments BD and CJ);

[0036] the line segment PN is represented by coordinates (x, $-0.1135x^2+12.112x-280.43$, $0.1135x^2-13.112x+380.43$),

[0037] the line segment NK is represented by coordinates (x, $0.2421x^2-29.955x+931.91$, $-0.2421x^2+28.955x-831.91$),

[0038] the line segment KA' is represented by coordinates (x, $0.0016x^2-0.9473x+57.497$, $-0.0016x^2-0.0527x+42.503$),

[0039] the line segment A'B is represented by coordinates (x, $0.0029x^2-1.0268x+58.7$, $-0.0029x^2+0.0268x+41.3$),

[0040] the line segment DC' is represented by coordinates (x, $0.0082x^2-0.6671x+80.4$, $-0.0082x^2-0.3329x+19.6$),

[0041] the line segment C'C is represented by coordinates (x, $0.0067x^2-0.6034x+79.729$, $-0.0067x^2-0.3966x+20.271$), and

[0042] the line segments JP, BD, and CG are straight lines.

[0043] A refrigeration cycle apparatus according to a seventh aspect is the refrigeration cycle apparatus according to the third aspect, wherein

[0044] when the mass % of HFO-1132(E), HFO-1123, and R1234yf based on their sum in the refrigerant is respectively represented by x, y, and z, coordinates (x,y,z) in a ternary composition diagram in which the sum of HFO-1132(E), HFO-1123, and R1234yf is 100 mass % are within the range of a figure surrounded by line segments JP, PL, LM, MA', A'B, BD, DC', C'C, and CJ that connect the following 9 points:

point J (47.1, 52.9, 0.0),
 point P (55.8, 42.0, 2.2),
 point L (63.1, 31.9, 5.0),
 point M (60.3, 6.2, 33.5),
 point A' (30.6, 30.0, 39.4),
 point B (0.0, 58.7, 41.3),
 point D (0.0, 80.4, 19.6),
 point C' (19.5, 70.5, 10.0), and
 point C (32.9, 67.1, 0.0),

or on the above line segments (excluding the points on the line segments BD and CJ);

[0045] the line segment PL is represented by coordinates (x, $-0.1135x^2+12.112x-280.43$, $0.1135x^2-13.112x+380.43$)

[0046] the line segment MA' is represented by coordinates (x, $0.0016x^2-0.9473x+57.497$, $-0.0016x^2-0.0527x+42.503$),

[0047] the line segment A'B is represented by coordinates (x, $0.0029x^2-1.0268x+58.7$, $-0.0029x^2+0.0268x+41.3$),

[0048] the line segment DC' is represented by coordinates (x, $0.0082x^2-0.6671x+80.4$, $-0.0082x^2-0.3329x+19.6$),

[0049] the line segment C'C is represented by coordinates (x, $0.0067x^2-0.6034x+79.729$, $-0.0067x^2-0.3966x+20.271$), and

[0050] the line segments JP, LM, BD, and CG are straight lines.

[0051] A refrigeration cycle apparatus according to an eighth aspect is the refrigeration cycle apparatus according to the third aspect, wherein

[0052] when the mass % of HFO-1132(E), HFO-1123, and R1234yf based on their sum in the refrigerant is respectively represented by x, y, and z, coordinates (x,y,z) in a ternary composition diagram in which the sum of HFO-1132(E), HFO-1123, and R1234yf is 100 mass % are within the range of a figure surrounded by line segments PL, LM, MA', A'B, BF, FT, and TP that connect the following 7 points:

point P (55.8, 42.0, 2.2),
 point L (63.1, 31.9, 5.0),
 point M (60.3, 6.2, 33.5),
 point A' (30.6, 30.0, 39.4),
 point B (0.0, 58.7, 41.3),
 point F (0.0, 61.8, 38.2), and
 point T (35.8, 44.9, 19.3),

or on the above line segments (excluding the points on the line segment BF);

[0053] the line segment PL is represented by coordinates (x, $-0.1135x^2+12.112x-280.43$, $0.1135x^2-13.112x+380.43$),

[0054] the line segment MA' is represented by coordinates (x, $0.0016x^2-0.9473x+57.497$, $-0.0016x^2-0.0527x+42.503$),

[0055] the line segment A'B is represented by coordinates (x, $0.0029x^2-1.0268x+58.7$, $-0.0029x^2+0.0268x+41.3$),

[0056] the line segment FT is represented by coordinates (x, $0.0078x^2-0.7501x+61.8$, $-0.0078x^2-0.2499x+38.2$),

[0057] the line segment TP is represented by coordinates (x, $0.00672x^2-0.7607x+63.525$, $-0.00672x^2-0.2393x+36.475$), and

[0058] the line segments LM and BF are straight lines.

[0059] A refrigeration cycle apparatus according to a ninth aspect is the refrigeration cycle apparatus according to the third aspect, wherein

[0060] when the mass % of HFO-1132(E), HFO-1123, and R1234yf based on their sum in the refrigerant is respectively represented by x, y, and z, coordinates (x,y,z) in a ternary composition diagram in which the sum of HFO-1132(E), HFO-1123, and R1234yf is 100 mass % are within the range of a figure surrounded by line segments PL, LQ, QR, and RP that connect the following 4 points:

point P (55.8, 42.0, 2.2),
 point L (63.1, 31.9, 5.0),
 point Q (62.8, 29.6, 7.6), and
 point R (49.8, 42.3, 7.9),

or on the above line segments;

[0061] the line segment PL is represented by coordinates (x, $-0.1135x^2+12.112x-280.43$, $0.1135x^2-13.112x+380.43$),

[0062] the line segment RP is represented by coordinates $(x, 0.00672x^2 - 0.7607x + 63.525, -0.00672x^2 - 0.2393x + 36.475)$, and

[0063] the line segments LQ and QR are straight lines.

[0064] A refrigeration cycle apparatus according to a tenth aspect is the refrigeration cycle apparatus according to the third aspect, wherein

[0065] when the mass % of HFO-1132(E), HFO-1123, and R1234yf based on their sum in the refrigerant is respectively represented by x, y , and z , coordinates (x, y, z) in a ternary composition diagram in which the sum of HFO-1132(E), HFO-1123, and R1234yf is 100 mass % are within the range of a figure surrounded by line segments SM, MA', A'B, BF, FT, and TS that connect the following 6 points:

point S (62.6, 28.3, 9.1),

point M (60.3, 6.2, 33.5),

point A' (30.6, 30.0, 39.4),

point B (0.0, 58.7, 41.3),

point F (0.0, 61.8, 38.2), and

point T (35.8, 44.9, 19.3),

or on the above line segments,

[0066] the line segment MA' is represented by coordinates $(x, 0.0016x^2 - 0.9473x + 57.497, -0.0016x^2 - 0.0527x + 42.503)$,

[0067] the line segment A'B is represented by coordinates $(x, 0.0029x^2 - 1.0268x + 58.7, -0.0029x^2 + 0.0268x + 41.3)$,

[0068] the line segment FT is represented by coordinates $(x, 0.0078x^2 - 0.7501x + 61.8, -0.0078x^2 - 0.2499x + 38.2)$,

[0069] the line segment TS is represented by coordinates $(x, -0.0017x^2 - 0.7869x + 70.888, -0.0017x^2 - 0.2131x + 29.112)$, and

[0070] the line segments SM and BF are straight lines.

[0071] A refrigeration cycle apparatus according to an eleventh aspect is the refrigeration cycle apparatus according to the first or second aspect, wherein

[0072] the refrigerant comprises trans-1,2-difluoroethylene (HFO-1132(E)) and trifluoroethylene (HFO-1123) in a total amount of 99.5 mass % or more based on the entire refrigerant, and

[0073] the refrigerant comprises 62.0 mass % to 72.0 mass % of HFO-1132(E) based on the entire refrigerant.

[0074] The refrigeration cycle apparatus can perform a refrigeration cycle using a refrigerant having properties including a sufficiently small GWP, a coefficient of performance (COP) and a refrigeration capacity (possibly referred to as cooling capacity or capacity) equivalent to those of R410A, and being classified with lower flammability (class 2L) according to the standard of the American Society of Heating, Refrigerating and Air-Conditioning Engineers (ASHRAE).

[0075] A refrigeration cycle apparatus according to a twelfth aspect is the refrigeration cycle apparatus according to the first or second aspect, wherein

[0076] the refrigerant comprises HFO-1132(E) and HFO-1123 in a total amount of 99.5 mass % or more based on the entire refrigerant, and

[0077] the refrigerant comprises 45.1 mass % to 47.1 mass % of HFO-1132(E) based on the entire refrigerant.

[0078] The refrigeration cycle apparatus can perform a refrigeration cycle using a refrigerant having properties including a sufficiently small GWP, a coefficient of performance (COP) and a refrigeration capacity (possibly referred to as cooling capacity or capacity) equivalent to those of R410A, and being classified with lower flammability (class

2L) according to the standard of the American Society of Heating, Refrigerating and Air-Conditioning Engineers (ASHRAE).

[0079] A refrigeration cycle apparatus according to a thirteenth aspect is the refrigeration cycle apparatus according to the first or second aspect, wherein

[0080] the refrigerant comprises trans-1,2-difluoroethylene (HFO-1132(E)), trifluoroethylene (HFO-1123), 2,3,3,3-tetrafluoro-1-propene (R1234yf), and difluoromethane (R32),

wherein

[0081] when the mass % of HFO-1132(E), HFO-1123, R1234yf, and R32 based on their sum in the refrigerant is respectively represented by x, y, z , and a ,

[0082] if $0 < a \leq 11.1$, coordinates (x, y, z) in a ternary composition diagram in which the sum of HFO-1132(E), HFO-1123, and R1234yf is $(100 - a)$ mass % are within the range of a figure surrounded by straight lines GI, IA, AB, BD', D'C, and CG that connect the following 6 points:

point G $(0.026a^2 - 1.7478a + 72.0, -0.026a^2 + 0.7478a + 28.0, 0.0)$,

point I $(0.026a^2 - 1.7478a + 72.0, 0.0, -0.026a^2 + 0.7478a + 28.0)$,

point A $(0.0134a^2 - 1.9681a + 68.6, 0.0, -0.0134a^2 + 0.9681a + 31.4)$,

point B $(0.0, 0.0144a^2 - 1.6377a + 58.7, -0.0144a^2 + 0.6377a + 41.3)$,

point D' $(0.0, 0.0224a^2 + 0.968a + 75.4, -0.0224a^2 - 1.968a + 24.6)$, and

point C $(-0.2304a^2 - 0.4062a + 32.9, 0.2304a^2 - 0.5938a + 67.1, 0.0)$,

or on the straight lines GI, AB, and D'C (excluding point G, point I, point A, point B, point D', and point C);

[0083] if $11.1 < a \leq 18.2$, coordinates (x, y, z) in the ternary composition diagram are within the range of a figure surrounded by straight lines GI, IA, AB, BW, and WG that connect the following 5 points:

point G $(0.02a^2 - 1.6013a + 71.105, -0.02a^2 + 0.6013a + 28.895, 0.0)$,

point I $(0.02a^2 - 1.6013a + 71.105, 0.0, -0.02a^2 + 0.6013a + 28.895)$,

point A $(0.0112a^2 - 1.9337a + 68.484, 0.0, -0.0112a^2 + 0.9337a + 31.516)$,

point B $(0.0, 0.0075a^2 - 1.5156a + 58.199, -0.0075a^2 + 0.5156a + 41.801)$, and

point W $(0.0, 100.0 - a, 0.0)$,

or on the straight lines GI and AB (excluding point G, point I, point A, point B, and point W);

[0084] if $18.2 < a \leq 26.7$, coordinates (x, y, z) in the ternary composition diagram are within the range of a figure surrounded by straight lines GI, IA, AB, BW, and WG that connect the following 5 points:

point G $(0.0135a^2 - 1.4068a + 69.727, -0.0135a^2 + 0.4068a + 30.273, 0.0)$,

point I $(0.0135a^2 - 1.4068a + 69.727, 0.0, -0.0135a^2 + 0.4068a + 30.273)$,

point A $(0.0107a^2 - 1.9142a + 68.305, 0.0, -0.0107a^2 + 0.9142a + 31.695)$,

point B $(0.0, 0.009a^2 - 1.6045a + 59.318, -0.009a^2 + 0.6045a + 40.682)$, and

point W $(0.0, 100.0 - a, 0.0)$,

or on the straight lines GI and AB (excluding point G, point I, point A, point B, and point W);

[0085] if $26.7 < a \leq 36.7$, coordinates (x,y,z) in the ternary composition diagram are within the range of a figure surrounded by straight lines GI, IA, AB, BW, and WG that connect the following 5 points:

point G ($0.0111a^2 - 1.3152a + 68.986$, $-0.0111a^2 + 0.3152a + 31.014$, 0.0),

point I ($0.0111a^2 - 1.3152a + 68.986$, 0.0, $-0.0111a^2 + 0.3152a + 31.014$),

point A ($0.0103a^2 - 1.9225a + 68.793$, 0.0, $-0.0103a^2 + 0.9225a + 31.207$),

point B (0.0, $0.0046a^2 - 1.41a + 57.286$, $-0.0046a^2 + 0.41a + 42.714$), and

point W (0.0, $100.0 - a$, 0.0),

or on the straight lines GI and AB (excluding point G, point I, point A, point B, and point W); and

[0086] if $36.7 < a \leq 46.7$, coordinates (x,y,z) in the ternary composition diagram are within the range of a figure surrounded by straight lines GI, IA, AB, BW, and WG that connect the following 5 points:

point G ($0.0061a^2 - 0.9918a + 63.902$, $-0.0061a^2 - 0.0082a + 36.098$, 0.0),

point I ($0.0061a^2 - 0.9918a + 63.902$, 0.0, $-0.0061a^2 - 0.0082a + 36.098$),

point A ($0.0085a^2 - 1.8102a + 67.1$, 0.0, $-0.0085a^2 + 0.8102a + 32.9$),

point B (0.0, $0.0012a^2 - 1.1659a + 52.95$, $-0.0012a^2 + 0.1659a + 47.05$), and

point W (0.0, $100.0 - a$, 0.0),

or on the straight lines GI and AB (excluding point G, point I, point A, point B, and point W).

[0087] The refrigeration cycle apparatus can perform a refrigeration cycle using a refrigerant having properties including a sufficiently small GWP, and a refrigeration capacity (possibly referred to as cooling capacity or capacity) and a coefficient of performance (COP) equivalent to those of R410A.

[0088] A refrigeration cycle apparatus according to a fourteenth aspect is the refrigeration cycle apparatus according to the first or second aspect, wherein

[0089] the refrigerant comprises trans-1,2-difluoroethylene (HFO-1132(E)), trifluoroethylene (HFO-1123), 2,3,3,3-tetrafluoro-1-propene (R1234yf), and difluoromethane (R32),

wherein

[0090] when the mass % of HFO-1132(E), HFO-1123, R1234yf, and R32 based on their sum in the refrigerant is respectively represented by x, y, z, and a, if $0 < a \leq 11.1$, coordinates (x,y,z) in a ternary composition diagram in which the sum of HFO-1132(E), HFO-1123, and R1234yf is (100-a) mass % are within the range of a figure surrounded by straight lines JK', K'B, BD', D'C, and CJ that connect the following 5 points:

point J ($0.0049a^2 - 0.9645a + 47.1$, $-0.0049a^2 - 0.0355a + 52.9$, 0.0),

point K' ($0.0514a^2 - 2.4353a + 61.7$, $-0.0323a^2 + 0.4122a + 5.9$, $-0.0191a^2 + 1.0231a + 32.4$),

point B (0.0, $0.0144a^2 - 1.6377a + 58.7$, $-0.0144a^2 + 0.6377a + 41.3$),

point D' (0.0, $0.0224a^2 + 0.968a + 75.4$, $-0.0224a^2 - 1.968a + 24.6$), and

point C ($-0.2304a^2 - 0.4062a + 32.9$, $0.2304a^2 - 0.5938a + 67.1$, 0.0),

or on the straight lines JK', K'B, and D'C (excluding point J, point B, point D', and point C);

[0091] if $11.1 < a \leq 18.2$, coordinates (x,y,z) in the ternary composition diagram are within the range of a figure surrounded by straight lines JK', K'B, BW, and WJ that connect the following 4 points:

point J ($0.0243a^2 - 1.4161a + 49.725$, $-0.0243a^2 + 0.4161a + 50.275$, 0.0),

point K' ($0.0341a^2 - 2.1977a + 61.187$, $-0.0236a^2 + 0.34a + 5.636$, $-0.0105a^2 + 0.8577a + 33.177$),

point B (0.0, $0.0075a^2 - 1.5156a + 58.199$, $-0.0075a^2 + 0.5156a + 41.801$), and

point W (0.0, $100.0 - a$, 0.0),

or on the straight lines JK' and K'B (excluding point J, point B, and point W);

[0092] if $18.2 < a \leq 26.7$, coordinates (x,y,z) in the ternary composition diagram are within the range of a figure surrounded by straight lines JK', K'B, BW, and WJ that connect the following 4 points:

point J ($0.0246a^2 - 1.4476a + 50.184$, $-0.0246a^2 + 0.4476a + 49.816$, 0.0),

point K' ($0.0196a^2 - 1.7863a + 58.515$, $-0.0079a^2 - 0.1136a + 8.702$, $-0.0117a^2 + 0.8999a + 32.783$),

point B (0.0, $0.009a^2 - 1.6045a + 59.318$, $-0.009a^2 + 0.6045a + 40.682$), and

point W (0.0, $100.0 - a$, 0.0),

or on the straight lines JK' and K'B (excluding point J, point B, and point W);

[0093] if $26.7 < a \leq 36.7$, coordinates (x,y,z) in the ternary composition diagram are within the range of a figure surrounded by straight lines JK', K'A, AB, BW, and WJ that connect the following 5 points:

point J ($0.0183a^2 - 1.1399a + 46.493$, $-0.0183a^2 + 0.1399a + 53.507$, 0.0),

point K' ($-0.0051a^2 + 0.0929a + 25.95$, 0.0, $0.0051a^2 - 1.0929a + 74.05$),

point A ($0.0103a^2 - 1.9225a + 68.793$, 0.0, $-0.0103a^2 + 0.9225a + 31.207$),

point B (0.0, $0.0046a^2 - 1.41a + 57.286$, $-0.0046a^2 + 0.41a + 42.714$), and

point W (0.0, $100.0 - a$, 0.0),

or on the straight lines JK', K'A, and AB (excluding point J, point B, and point W); and

[0094] if $36.7 < a \leq 46.7$, coordinates (x,y,z) in the ternary composition diagram are within the range of a figure surrounded by straight lines JK', K'A, AB, BW, and WJ that connect the following 5 points:

point J ($-0.0134a^2 + 1.0956a + 7.13$, $0.0134a^2 - 2.0956a + 92.87$, 0.0),

point K' ($-1.892a + 29.443$, 0.0, $0.892a + 70.557$),

point A ($0.0085a^2 - 1.8102a + 67.1$, 0.0, $-0.0085a^2 + 0.8102a + 32.9$),

point B (0.0, $0.0012a^2 - 1.1659a + 52.95$, $-0.0012a^2 + 0.1659a + 47.05$), and

point W (0.0, $100.0 - a$, 0.0),

or on the straight lines JK', K'A, and AB (excluding point J, point B, and point W).

[0095] The refrigeration cycle apparatus can perform a refrigeration cycle using a refrigerant having properties including a sufficiently small GWP, and a refrigeration capacity (possibly referred to as cooling capacity or capacity) and a coefficient of performance (COP) equivalent to those of R410A.

[0096] A refrigeration cycle apparatus according to a fifteenth aspect is the refrigeration cycle apparatus according to the first or second aspect, wherein

[0097] the refrigerant comprises trans-1,2-difluoroethylene (HFO-1132(E)), difluoromethane (R32), and 2,3,3,3-tetrafluoro-1-propene (R1234yf), wherein

[0098] when the mass % of HFO-1132(E), R32, and R1234yf based on their sum in the refrigerant is respectively represented by x, y, and z, coordinates (x,y,z) in a ternary composition diagram in which the sum of HFO-1132(E), R32, and R1234yf is 100 mass % are within the range of a figure surrounded by line segments IJ, JN, NE, and EI that connect the following 4 points:

point I (72.0, 0.0, 28.0),
point J (48.5, 18.3, 33.2),
point N (27.7, 18.2, 54.1), and
point E (58.3, 0.0, 41.7),

or on these line segments (excluding the points on the line segment EI;

[0099] the line segment IJ is represented by coordinates $(0.0236y^2 - 1.7616y + 72.0, y, -0.0236y^2 + 0.7616y + 28.0)$;

[0100] the line segment NE is represented by coordinates $(0.012y^2 - 1.9003y + 58.3, y, -0.012y^2 + 0.9003y + 41.7)$; and

[0101] the line segments JN and EI are straight lines.

[0102] The refrigeration cycle apparatus can perform a refrigeration cycle using a refrigerant having properties including a sufficiently small GWP, a refrigeration capacity (possibly referred to as cooling capacity or capacity) equivalent to that of R410A, and being classified with lower flammability (class 2L) according to the standard of the American Society of Heating, Refrigerating and Air-Conditioning Engineers (ASHRAE).

[0103] A refrigeration cycle apparatus according to a sixteenth aspect is the refrigeration cycle apparatus according to the first or second aspect, wherein

[0104] the refrigerant comprises HFO-1132(E), R32, and R1234yf, wherein

[0105] when the mass % of HFO-1132(E), R32, and R1234yf based on their sum in the refrigerant is respectively represented by x, y, and z, coordinates (x,y,z) in a ternary composition diagram in which the sum of HFO-1132(E), R32, and R1234yf is 100 mass % are within the range of a figure surrounded by line segments MM', MN, NV, VG, and GM that connect the following 5 points:

point M (52.6, 0.0, 47.4),
point M' (39.2, 5.0, 55.8),
point N (27.7, 18.2, 54.1),
point V (11.0, 18.1, 70.9), and
point G (39.6, 0.0, 60.4),

or on these line segments (excluding the points on the line segment GM);

[0106] the line segment MM' is represented by coordinates $(0.132y^2 - 3.34y + 52.6, y, -0.132y^2 + 2.34y + 47.4)$;

[0107] the line segment M'N is represented by coordinates $(0.0596y^2 - 2.2541y + 48.98, y, -0.0596y^2 + 1.2541y + 51.02)$;

[0108] the line segment VG is represented by coordinates $(0.0123y^2 - 1.8033y + 39.6, y, -0.0123y^2 + 0.8033y + 60.4)$; and

[0109] the line segments NV and GM are straight lines.

[0110] The refrigeration cycle apparatus can perform a refrigeration cycle using a refrigerant having properties including a sufficiently small GWP, a refrigeration capacity (possibly referred to as cooling capacity or capacity) equivalent to that of R410A, and being classified with lower flammability (class 2L) according to the standard of the

American Society of Heating, Refrigerating and Air-Conditioning Engineers (ASHRAE).

[0111] A refrigeration cycle apparatus according to a seventeenth aspect is the refrigeration cycle apparatus according to the first or second aspect, wherein

[0112] the refrigerant comprises HFO-1132(E), R32, and R1234yf, wherein

[0113] when the mass % of HFO-1132(E), R32, and R1234yf based on their sum in the refrigerant is respectively represented by x, y and z, coordinates (x,y,z) in a ternary composition diagram in which the sum of HFO-1132(E), R32, and R1234yf is 100 mass % are within the range of a figure surrounded by line segments ON, NU, and UO that connect the following 3 points:

point O (22.6, 36.8, 40.6),
point N (27.7, 18.2, 54.1), and
point U (3.9, 36.7, 59.4),

or on these line segments;

[0114] the line segment ON is represented by coordinates $(0.0072y^2 - 0.6701y + 37.512, y, -0.0072y^2 - 0.3299y + 62.488)$;

[0115] the line segment NU is represented by coordinates $(0.0083y^2 - 1.7403y + 56.635, y, -0.0083y^2 + 0.7403y + 43.365)$; and

[0116] the line segment UO is a straight line.

[0117] The refrigeration cycle apparatus can perform a refrigeration cycle using a refrigerant having properties including a sufficiently small GWP, a refrigeration capacity (possibly referred to as cooling capacity or capacity) equivalent to that of R410A, and being classified with lower flammability (class 2L) according to the standard of the American Society of Heating, Refrigerating and Air-Conditioning Engineers (ASHRAE).

[0118] A refrigeration cycle apparatus according to an eighteenth aspect is the refrigeration cycle apparatus according to the first or second aspect, wherein

[0119] the refrigerant comprises HFO-1132(E), R32, and R1234yf, wherein

[0120] when the mass % of HFO-1132(E), R32, and R1234yf based on their sum in the refrigerant is respectively represented by x, y, and z, coordinates (x,y,z) in a ternary composition diagram in which the sum of HFO-1132(E), R32, and R1234yf is 100 mass % are within the range of a figure surrounded by line segments QR, RT, TL, LK, and KQ that connect the following 5 points:

point Q (44.6, 23.0, 32.4),
point R (25.5, 36.8, 37.7),
point T (8.6, 51.6, 39.8),
point L (28.9, 51.7, 19.4), and
point K (35.6, 36.8, 27.6),

or on these line segments;

[0121] the line segment QR is represented by coordinates $(0.0099y^2 - 1.975y + 84.765, y, -0.0099y^2 + 0.975y + 15.235)$;

[0122] the line segment RT is represented by coordinates $(0.0082y^2 - 1.8683y + 83.126, y, -0.0082y^2 + 0.8683y + 16.874)$;

[0123] the line segment LK is represented by coordinates $(0.0049y^2 - 0.8842y + 61.488, y, -0.0049y^2 - 0.1158y + 38.512)$;

[0124] the line segment KQ is represented by coordinates $(0.0095y^2 - 1.2222y + 67.676, y, -0.0095y^2 + 0.2222y + 32.324)$; and

[0125] the line segment TL is a straight line.

[0126] The refrigeration cycle apparatus can perform a refrigeration cycle using a refrigerant having properties including a sufficiently small GWP, a refrigeration capacity (possibly referred to as cooling capacity or capacity) equivalent to that of R410A, and being classified with lower flammability (class 2L) according to the standard of the American Society of Heating, Refrigerating and Air-Conditioning Engineers (ASHRAE).

[0127] A refrigeration cycle apparatus according to a nineteenth aspect is the refrigeration cycle apparatus according to the first or second aspect, wherein the refrigerant comprises HFO-1132(E), R32, and R1234yf, wherein

[0128] when the mass % of HFO-1132(E), R32, and R1234yf based on their sum in the refrigerant is respectively represented by x, y, and z, coordinates (x,y,z) in a ternary composition diagram in which the sum of HFO-1132(E), R32, and R1234yf is 100 mass % are within the range of a figure surrounded by line segments PS, ST, and TP that connect the following 3 points:

point P (20.5, 51.7, 27.8),

point S (21.9, 39.7, 38.4), and

point T (8.6, 51.6, 39.8),

or on these line segments;

[0129] the line segment PS is represented by coordinates $(0.0064y^2 - 0.7103y + 40.1, y, -0.0064y^2 - 0.2897y + 59.9)$;

[0130] the line segment ST is represented by coordinates $(0.0082y^2 - 1.8683y + 83.126, y, -0.0082y^2 + 0.8683y + 16.874)$; and

[0131] the line segment TP is a straight line.

[0132] The refrigeration cycle apparatus can perform a refrigeration cycle using a refrigerant having properties including a sufficiently small GWP, a refrigeration capacity (possibly referred to as cooling capacity or capacity) equivalent to that of R410A, and being classified with lower flammability (class 2L) according to the standard of the American Society of Heating, Refrigerating and Air-Conditioning Engineers (ASHRAE).

[0133] A refrigeration cycle apparatus according to a twentieth aspect is the refrigeration cycle apparatus according to the first or second aspect, wherein the refrigerant comprises trans-1,2-difluoroethylene (HFO-1132(E)), trifluoroethylene (HFO-1123), and difluoromethane (R32), wherein

[0134] when the mass % of HFO-1132(E), HFO-1123, and R32 based on their sum in the refrigerant is respectively represented by x, y, and z, coordinates (x,y,z) in a ternary composition diagram in which the sum of HFO-1132(E), HFO-1123, and R32 is 100 mass % are within the range of a figure surrounded by line segments IK, KB', B'H, HR, RG, and GI that connect the following 6 points:

point I (72.0, 28.0, 0.0),

point K (48.4, 33.2, 18.4),

point B' (0.0, 81.6, 18.4),

point H (0.0, 84.2, 15.8),

point R (23.1, 67.4, 9.5), and

point G (38.5, 61.5, 0.0),

or on these line segments (excluding the points on the line segments B'H and GI);

[0135] the line segment IK is represented by coordinates $(0.025z^2 - 1.7429z + 72.00, -0.025z^2 + 0.7429z + 28.0, z)$,

[0136] the line segment HR is represented by coordinates $(-0.3123z^2 + 4.234z + 11.06, 0.3123z^2 - 5.234z + 88.94, z)$,

[0137] the line segment RG is represented by coordinates $(-0.0491z^2 - 1.1544z + 38.5, 0.0491z^2 + 0.1544z + 61.5, z)$, and the line segments KB' and GI are straight lines.

[0138] The refrigeration cycle apparatus can perform a refrigeration cycle using a refrigerant having properties including a sufficiently small GWP, and a coefficient of performance (COP) equivalent to that of R410A.

[0139] A refrigeration cycle apparatus according to a twenty first aspect is the refrigeration cycle apparatus according to the first or second aspect, wherein

[0140] the refrigerant comprises HFO-1132(E), HFO-1123, and R32, wherein

[0141] when the mass % of HFO-1132(E), HFO-1123, and R32 based on their sum in the refrigerant is respectively represented by x, y, and z, coordinates (x,y,z) in a ternary composition diagram in which the sum of HFO-1132(E), HFO-1123, and R32 is 100 mass % are within the range of a figure surrounded by line segments IJ, JR, RG, and GI that connect the following 4 points:

point I (72.0, 28.0, 0.0),

point J (57.7, 32.8, 9.5),

point R (23.1, 67.4, 9.5), and

point G (38.5, 61.5, 0.0),

or on these line segments (excluding the points on the line segment GI);

[0142] the line segment IJ is represented by coordinates $(0.025z^2 - 1.7429z + 72.0, -0.025z^2 + 0.7429z + 28.0, z)$,

[0143] the line segment RG is represented by coordinates $(-0.0491z^2 - 1.1544z + 38.5, 0.0491z^2 + 0.1544z + 61.5, z)$, and

[0144] the line segments JR and GI are straight lines.

[0145] The refrigeration cycle apparatus can perform a refrigeration cycle using a refrigerant having properties including a sufficiently small GWP, and a coefficient of performance (COP) equivalent to that of R410A.

[0146] A refrigeration cycle apparatus according to a twenty second aspect is the refrigeration cycle apparatus according to the first or second aspect, wherein

[0147] the refrigerant comprises HFO-1132(E), HFO-1123, and R32, wherein

[0148] when the mass % of HFO-1132(E), HFO-1123, and R32 based on their sum in the refrigerant is respectively represented by x, y, and z, coordinates (x,y,z) in a ternary composition diagram in which the sum of HFO-1132(E), HFO-1123, and R32 is 100 mass % are within the range of a figure surrounded by line segments MP, PB', B'H, HR, RG, and GM that connect the following 6 points:

point M (47.1, 52.9, 0.0),

point P (31.8, 49.8, 18.4),

point B' (0.0, 81.6, 18.4),

point H (0.0, 84.2, 15.8),

point R (23.1, 67.4, 9.5), and

point G (38.5, 61.5, 0.0),

or on these line segments (excluding the points on the line segments B'H and GM);

[0149] the line segment MP is represented by coordinates $(0.0083z^2 - 0.984z + 47.1, -0.0083z^2 - 0.016z + 52.9, z)$,

[0150] the line segment HR is represented by coordinates $(-0.3123z^2 + 4.234z + 11.06, 0.3123z^2 - 5.234z + 88.94, z)$,

[0151] the line segment RG is represented by coordinates $(-0.0491z^2 - 1.1544z + 38.5, 0.0491z^2 + 0.1544z + 61.5, z)$, and

[0152] the line segments PB' and GM are straight lines.

[0153] The refrigeration cycle apparatus can perform a refrigeration cycle using a refrigerant having properties including a sufficiently small GWP, and a coefficient of performance (COP) equivalent to that of R410A.

[0154] A refrigeration cycle apparatus according to a twenty third aspect is the refrigeration cycle apparatus according to the first or second aspect, wherein

[0155] the refrigerant comprises HFO-1132(E), HFO-1123, and R32, wherein

[0156] when the mass % of HFO-1132(E), HFO-1123, and R32 based on their sum in the refrigerant is respectively represented by x, y, and z, coordinates (x,y,z) in a ternary composition diagram in which the sum of HFO-1132(E), HFO-1123, and R32 is 100 mass % are within the range of a figure surrounded by line segments MN, NR, RG, and GM that connect the following 4 points:

point M (47.1, 52.9, 0.0),

point N (38.5, 52.1, 9.5),

point R (23.1, 67.4, 9.5), and

point G (38.5, 61.5, 0.0),

or on these line segments (excluding the points on the line segment GM);

[0157] the line segment MN is represented by coordinates $(0.0083z^2 - 0.984z + 47.1, -0.0083z^2 - 0.016z + 52.9, z)$,

[0158] the line segment RG is represented by coordinates $(-0.0491z^2 - 1.1544z + 38.5, 0.0491z^2 + 0.1544z + 61.5, z)$, and

[0159] the line segments JR and GI are straight lines.

[0160] The refrigeration cycle apparatus can perform a refrigeration cycle using a refrigerant having properties including a sufficiently small GWP, and a coefficient of performance (COP) equivalent to that of R410A.

[0161] A refrigeration cycle apparatus according to a twenty fourth aspect is the refrigeration cycle apparatus according to the first or second aspect, wherein

[0162] the refrigerant comprises HFO-1132(E), HFO-1123, and R32, wherein

[0163] when the mass % of HFO-1132(E), HFO-1123, and R32 based on their sum in the refrigerant is respectively represented by x, y, and z, coordinates (x,y,z) in a ternary composition diagram in which the sum of HFO-1132(E), HFO-1123, and R32 is 100 mass % are within the range of a figure surrounded by line segments PS, ST, and TP that connect the following 3 points:

point P (31.8, 49.8, 18.4),

point S (25.4, 56.2, 18.4), and

point T (34.8, 51.0, 14.2),

or on these line segments;

[0164] the line segment ST is represented by coordinates $(-0.0982z^2 + 0.9622z + 40.931, 0.0982z^2 - 1.9622z + 59.069, z)$,

[0165] the line segment TP is represented by coordinates $(0.0083z^2 - 0.984z + 47.1, -0.0083z^2 - 0.016z + 52.9, z)$, and

[0166] the line segment PS is a straight line.

[0167] The refrigeration cycle apparatus can perform a refrigeration cycle using a refrigerant having properties including a sufficiently small GWP, and a coefficient of performance (COP) equivalent to that of R410A.

[0168] A refrigeration cycle apparatus according to a twenty fifth aspect is the refrigeration cycle apparatus according to the first or second aspect, wherein the refrigerant comprises HFO-1132(E), HFO-1123, and R32,

wherein

[0169] when the mass % of HFO-1132(E), HFO-1123, and R32 based on their sum in the refrigerant is respectively represented by x, y, and z, coordinates (x,y,z) in a ternary composition diagram in which the sum of HFO-1132(E), HFO-1123, and R32 is 100 mass % are within the range of a figure surrounded by line segments QB", B"D, DU, and UQ that connect the following 4 points:

point Q (28.6, 34.4, 37.0),

point B" (0.0, 63.0, 37.0),

point D (0.0, 67.0, 33.0), and

point U (28.7, 41.2, 30.1),

or on these line segments (excluding the points on the line segment B"D);

[0170] the line segment DU is represented by coordinates $(-3.4962z^2 + 210.71z - 3146.1, 3.4962z^2 - 211.71z + 3246.1, z)$,

[0171] the line segment UQ is represented by coordinates $(0.0135z^2 - 0.9181z + 44.133, -0.0135z^2 - 0.0819z + 55.867, z)$, and

[0172] the line segments QB" and B"D are straight lines.

[0173] The refrigeration cycle apparatus can perform a refrigeration cycle using a refrigerant having properties including a sufficiently small GWP, and a coefficient of performance (COP) equivalent to that of R410A.

[0174] A method of determining a refrigerant enclosure amount in a refrigeration cycle apparatus according to a twenty-sixth aspect, for a refrigeration cycle apparatus including a heat source unit including a compressor and a heat-source-side heat exchanger, a service unit including a service-side heat exchanger, and a refrigerant pipe that connects the heat source unit and the service unit to each other, and for a refrigerant containing at least 1,2-difluoroethylene being enclosed in a refrigerant circuit that is constituted by connecting the compressor, the heat-source-side heat exchanger, and the service-side heat exchanger to one another, sets an enclosure amount of the refrigerant in the refrigerant circuit per 1 kW of refrigeration capacity to 160 g or more and 560 g or less. The method of determining the refrigerant enclosure amount, for a refrigeration cycle apparatus including a heat source unit including a compressor and a heat-source-side heat exchanger, a first service unit including a first service-side heat exchanger, a second service unit including a second service-side heat exchanger, and a refrigerant pipe that connects the heat source unit, the first service unit, and the second service unit to one another, and for a refrigerant containing at least 1,2-difluoroethylene being enclosed in a refrigerant circuit that is constituted by connecting the first service-side heat exchanger and the second service-side heat exchanger in parallel to the compressor and the heat-source-side heat exchanger, sets an enclosure amount of the refrigerant in the refrigerant circuit per 1 kW of refrigeration capacity to 190 g or more and 1660 g or less.

[0175] With the method of determining the refrigerant enclosure amount, when a heat cycle is performed using a sufficiently small GWP, a refrigeration cycle apparatus having a LCCP kept low can be provided.

[0176] Note that, for the inner capacity (the volume of a fluid with which the inside can be filled) of the heat-source-side heat exchanger of the refrigeration cycle apparatus provided with one service unit, when the refrigerant circuit is not provided with a refrigerant container (for example, a low-pressure receiver or a high-pressure receiver, excluding an accumulator belonging to a compressor), the inner capac-

ity is preferably 0.4 L or more and 2.5 L or less. When the refrigerant circuit is provided with a refrigerant container, the inner capacity is preferably 1.4 L or more and less than 5.0 L.

[0177] Moreover, regarding the refrigeration cycle apparatus provided with one service unit, for the inner capacity (the volume of a fluid with which the inside can be filled) of the heat-source-side heat exchanger included in the heat source unit provided with only one fan, when the heat source unit has a casing having a blow-out port for blowing out the air which has passed through the heat-source-side heat exchanger in a side surface in an installed state (when the heat source unit is trunk type or the like), the inner capacity is preferably 0.4 L or more and less than 3.5 L. For the inner capacity (the volume of a fluid with which the inside can be filled) of the heat-source-side heat exchanger included in the heat source unit provided with two fans, when the heat source unit has a casing having a blow-out port for blowing out the air which has passed through the heat-source-side heat exchanger in a side surface in an installed state (when the heat source unit is trunk type or the like), the inner capacity is preferably 3.5 L or more and less than 5.0 L.

[0178] Note that, for the inner capacity (the volume of a fluid with which the inside can be filled) of the heat-source-side heat exchanger of the refrigeration cycle apparatus provided with the first service unit and the second service unit, when the first service unit does not have an expansion valve on the liquid side of the first service-side heat exchanger and the second service unit also does not have an expansion valve on the liquid side of the second service-side heat exchanger, the inner capacity is preferably 1.4 L or more and less than 5.0 L. When the first service unit has an expansion valve on the liquid side of the first service-side heat exchanger and the second service unit also has an expansion valve on the liquid side of the second service-side heat exchanger, the inner capacity is preferably 5.0 L or more and 38 L or less.

[0179] Moreover, regarding the refrigeration cycle apparatus provided with the first service unit and the second service unit, for the inner capacity (the volume of a fluid with which the inside can be filled) of the heat-source-side heat exchanger included in the heat source unit provided with only one fan, when the heat source unit has a casing having a blow-out port for blowing out the air which has passed through the heat-source-side heat exchanger in a side surface in an installed state (when the heat source unit is trunk type or the like), the inner capacity is preferably 0.4 L or more and less than 3.5 L. For the inner capacity (the volume of a fluid with which the inside can be filled) of the heat-source-side heat exchanger included in the heat source unit provided with two fans, when the heat source unit has a casing having a blow-out port for blowing out the air which has passed through the heat-source-side heat exchanger in a side surface in an installed state (when the heat source unit is trunk type or the like), the inner capacity is preferably 3.5 L or more and 7.0 L or less. For the inner capacity (the volume of a fluid with which the inside can be filled) of the heat-source-side heat exchanger included in the heat source unit that blows out upward the air which has passed through the heat-source-side heat exchanger, the inner capacity is preferably 5.5 L or more and 38 L or less.

[0180] Note that the refrigerant for the method of determining the refrigerant enclosure amount in the refrigeration cycle apparatus according to the twenty-sixth aspect may be

the same refrigerant as the refrigerant used for the refrigeration cycle apparatus according to any one of the third aspect to the twenty-fifth aspect.

BRIEF DESCRIPTION OF THE DRAWINGS

[0181] FIG. 1 is a schematic view of an instrument used for a flammability test.

[0182] FIG. 2 is a diagram showing points A to T and line segments that connect these points in a ternary composition diagram in which the sum of HFO-1132(E), HFO-1123, and R1234yf is 100 mass %.

[0183] FIG. 3 is a diagram showing points A to C, D', G, I, J, and K', and line segments that connect these points to each other in a ternary composition diagram in which the sum of HFO-1132(E), HFO-1123, and R1234yf is (100-a) mass %.

[0184] FIG. 4 is a diagram showing points A to C, D', G, I, J, and K', and line segments that connect these points to each other in a ternary composition diagram in which the sum of HFO-1132(E), HFO-1123, and R1234yf is 92.9 mass % (the content of R32 is 7.1 mass %).

[0185] FIG. 5 is a diagram showing points A to C, D', G, I, J, K', and W, and line segments that connect these points to each other in a ternary composition diagram in which the sum of HFO-1132(E), HFO-1123, and R1234yf is 88.9 mass % (the content of R32 is 11.1 mass %).

[0186] FIG. 6 is a diagram showing points A, B, G, I, J, K', and W, and line segments that connect these points to each other in a ternary composition diagram in which the sum of HFO-1132(E), HFO-1123, and R1234yf is 85.5 mass % (the content of R32 is 14.5 mass %).

[0187] FIG. 7 is a diagram showing points A, B, G, I, J, K', and W, and line segments that connect these points to each other in a ternary composition diagram in which the sum of HFO-1132(E), HFO-1123, and R1234yf is 81.8 mass % (the content of R32 is 18.2 mass %).

[0188] FIG. 8 is a diagram showing points A, B, G, I, J, K', and W, and line segments that connect these points to each other in a ternary composition diagram in which the sum of HFO-1132(E), HFO-1123, and R1234yf is 78.1 mass % (the content of R32 is 21.9 mass %).

[0189] FIG. 9 is a diagram showing points A, B, G, I, J, K', and W, and line segments that connect these points to each other in a ternary composition diagram in which the sum of HFO-1132(E), HFO-1123, and R1234yf is 73.3 mass % (the content of R32 is 26.7 mass %).

[0190] FIG. 10 is a diagram showing points A, B, G, I, J, K', and W, and line segments that connect these points to each other in a ternary composition diagram in which the sum of HFO-1132(E), HFO-1123, and R1234yf is 70.7 mass % (the content of R32 is 29.3 mass %).

[0191] FIG. 11 is a diagram showing points A, B, G, I, J, K', and W, and line segments that connect these points to each other in a ternary composition diagram in which the sum of HFO-1132(E), HFO-1123, and R1234yf is 63.3 mass % (the content of R32 is 36.7 mass %).

[0192] FIG. 12 is a diagram showing points A, B, G, I, J, K', and W, and line segments that connect these points to each other in a ternary composition diagram in which the sum of HFO-1132(E), HFO-1123, and R1234yf is 55.9 mass % (the content of R32 is 44.1 mass %).

[0193] FIG. 13 is a diagram showing points A, B, G, I, J, K', and W, and line segments that connect these points to each other in a ternary composition diagram in which the

sum of HFO-1132(E), HFO-1123, and R1234yf is 52.2 mass % (the content of R32 is 47.8 mass %).

[0194] FIG. 14 is a view showing points A to C, E, G, and I to W; and line segments that connect points A to C, E, G, and I to W in a ternary composition diagram in which the sum of HFO-1132(E), R32, and R1234yf is 100 mass %.

[0195] FIG. 15 is a view showing points A to U; and line segments that connect the points in a ternary composition diagram in which the sum of HFO-1132(E), HFO-1123, and R32 is 100 mass %.

[0196] FIG. 16 is a schematic configuration diagram of a refrigerant circuit according to a first embodiment.

[0197] FIG. 17 is a schematic control block configuration diagram of a refrigeration cycle apparatus according to the first embodiment.

[0198] FIG. 18 is a schematic configuration diagram of a refrigerant circuit according to a second embodiment.

[0199] FIG. 19 is a schematic control block configuration diagram of a refrigeration cycle apparatus according to the second embodiment.

[0200] FIG. 20 is a schematic configuration diagram of a refrigerant circuit according to a third embodiment.

[0201] FIG. 21 is a schematic control block configuration diagram of a refrigeration cycle apparatus according to the third embodiment.

DESCRIPTION OF EMBODIMENTS

(1) Definition of Terms

[0202] In the present specification, the term “refrigerant” includes at least compounds that are specified in ISO 817 (International Organization for Standardization), and that are given a refrigerant number (ASHRAE number) representing the type of refrigerant with “R” at the beginning; and further includes refrigerants that have properties equivalent to those of such refrigerants, even though a refrigerant number is not yet given. Refrigerants are broadly divided into fluorocarbon compounds and non-fluorocarbon compounds in terms of the structure of the compounds. Fluorocarbon compounds include chlorofluorocarbons (CFC), hydrochlorofluorocarbons (HCFC), and hydrofluorocarbons (HFC). Non-fluorocarbon compounds include propane (R290), propylene (R1270), butane (R600), isobutane (R600a), carbon dioxide (R744), ammonia (R717), and the like.

[0203] In the present specification, the phrase “composition comprising a refrigerant” at least includes (1) a refrigerant itself (including a mixture of refrigerants), (2) a composition that further comprises other components and that can be mixed with at least a refrigeration oil to obtain a working fluid for a refrigerating machine, and (3) a working fluid for a refrigerating machine containing a refrigeration oil. In the present specification, of these three embodiments, the composition (2) is referred to as a “refrigerant composition” so as to distinguish it from a refrigerant itself (including a mixture of refrigerants). Further, the working fluid for a refrigerating machine (3) is referred to as a “refrigeration oil-containing working fluid” so as to distinguish it from the “refrigerant composition.”

[0204] In the present specification, when the term “alternative” is used in a context in which the first refrigerant is replaced with the second refrigerant, the first type of “alternative” means that equipment designed for operation using the first refrigerant can be operated using the second refrigerant

under optimum conditions, optionally with changes of only a few parts (at least one of the following: refrigeration oil, gasket, packing, expansion valve, dryer, and other parts) and equipment adjustment. In other words, this type of alternative means that the same equipment is operated with an alternative refrigerant. Embodiments of this type of “alternative” include “drop-in alternative,” “nearly drop-in alternative,” and “retrofit,” in the order in which the extent of changes and adjustment necessary for replacing the first refrigerant with the second refrigerant is smaller.

[0205] The term “alternative” also includes a second type of “alternative,” which means that equipment designed for operation using the second refrigerant is operated for the same use as the existing use with the first refrigerant by using the second refrigerant. This type of alternative means that the same use is achieved with an alternative refrigerant.

[0206] In the present specification, the term “refrigerating machine” refers to machines in general that draw heat from an object or space to make its temperature lower than the temperature of ambient air, and maintain a low temperature. In other words, refrigerating machines refer to conversion machines that gain energy from the outside to do work, and that perform energy conversion, in order to transfer heat from where the temperature is lower to where the temperature is higher.

[0207] In the present specification, a refrigerant having a “WCF lower flammability” means that the most flammable composition (worst case of formulation for flammability: WCF) has a burning velocity of 10 cm/s or less according to the US ANSI/ASHRAE Standard 34-2013. Further, in the present specification, a refrigerant having “ASHRAE lower flammability” means that the burning velocity of WCF is 10 cm/s or less, that the most flammable fraction composition (worst case of fractionation for flammability: WFFF), which is specified by performing a leakage test during storage, shipping, or use based on ANSI/ASHRAE 34-2013 using WCF, has a burning velocity of 10 cm/s or less, and that flammability classification according to the US ANSI/ASHRAE Standard 34-2013 is determined to be classified as “Class 2L.”

[0208] In the present specification, a refrigerant having an “RCL of x % or more” means that the refrigerant has a refrigerant concentration limit (RCL), calculated in accordance with the US ANSI/ASHRAE Standard 34-2013, of x % or more. RCL refers to a concentration limit in the air in consideration of safety factors. RCL is an index for reducing the risk of acute toxicity, suffocation, and flammability in a closed space where humans are present. RCL is determined in accordance with the ASHRAE Standard. More specifically, RCL is the lowest concentration among the acute toxicity exposure limit (ATEL), the oxygen deprivation limit (ODL), and the flammable concentration limit (FCL), which are respectively calculated in accordance with sections 7.1.1, 7.1.2, and 7.1.3 of the ASHRAE Standard.

[0209] In the present specification, temperature glide refers to an absolute value of the difference between the initial temperature and the end temperature in the phase change process of a composition containing the refrigerant of the present disclosure in the heat exchanger of a refrigerant system.

(2) Refrigerant

(2-1) Refrigerant Component

[0210] Any one of various refrigerants such as refrigerant A, refrigerant B, refrigerant C, refrigerant D, and refrigerant E, details of these refrigerant are to be mentioned later, can be used as the refrigerant.

(2-2) Use of Refrigerant

[0211] The refrigerant according to the present disclosure can be preferably used as a working fluid in a refrigerating machine.

[0212] The composition according to the present disclosure is suitable for use as an alternative refrigerant for HFC refrigerant such as R410A, R407C and R404 etc, or HCFC refrigerant such as R22 etc.

(3) Refrigerant Composition

[0213] The refrigerant composition according to the present disclosure comprises at least the refrigerant according to the present disclosure, and can be used for the same use as the refrigerant according to the present disclosure. Moreover, the refrigerant composition according to the present disclosure can be further mixed with at least a refrigeration oil to thereby obtain a working fluid for a refrigerating machine.

[0214] The refrigerant composition according to the present disclosure further comprises at least one other component in addition to the refrigerant according to the present disclosure. The refrigerant composition according to the present disclosure may comprise at least one of the following other components, if necessary. As described above, when the refrigerant composition according to the present disclosure is used as a working fluid in a refrigerating machine, it is generally used as a mixture with at least a refrigeration oil.

[0215] Therefore, it is preferable that the refrigerant composition according to the present disclosure does not substantially comprise a refrigeration oil. Specifically, in the refrigerant composition according to the present disclosure, the content of the refrigeration oil based on the entire refrigerant composition is preferably 0 to 1 mass %, and more preferably 0 to 0.1 mass %.

(3-1) Water

[0216] The refrigerant composition according to the present disclosure may contain a small amount of water. The water content of the refrigerant composition is preferably 0.1 mass % or less based on the entire refrigerant. A small amount of water contained in the refrigerant composition stabilizes double bonds in the molecules of unsaturated fluorocarbon compounds that can be present in the refrigerant, and makes it less likely that the unsaturated fluorocarbon compounds will be oxidized, thus increasing the stability of the refrigerant composition.

(3-2) Tracer

[0217] A tracer is added to the refrigerant composition according to the present disclosure at a detectable concentration such that when the refrigerant composition has been diluted, contaminated, or undergone other changes, the tracer can trace the changes.

[0218] The refrigerant composition according to the present disclosure may comprise a single tracer, or two or more tracers.

[0219] The tracer is not limited, and can be suitably selected from commonly used tracers. Preferably, a compound that cannot be an impurity inevitably mixed in the refrigerant of the present disclosure is selected as the tracer.

[0220] Examples of tracers include hydrofluorocarbons, hydrochlorofluorocarbons, chlorofluorocarbons, hydrochlorocarbons, fluorocarbons, deuterated hydrocarbons, deuterated hydrofluorocarbons, perfluorocarbons, fluoroethers, brominated compounds, iodinated compounds, alcohols, aldehydes, ketones, and nitrous oxide (N₂O). The tracer is particularly preferably a hydrofluorocarbon, a hydrochlorofluorocarbon, a chlorofluorocarbon, a fluorocarbon, a hydrochlorocarbon, a fluorocarbon, or a fluoroether.

[0221] The following compounds are preferable as the tracer.

[0222] FC-14 (tetrafluoromethane, CF₄)

[0223] HCC-40 (chloromethane, CH₃Cl)

[0224] HFC-23 (trifluoromethane, CHF₃)

[0225] HFC-41 (fluoromethane, CH₃Cl)

[0226] HFC-125 (pentafluoroethane, CF₃CHF₂)

[0227] HFC-134a (1,1,1,2-tetrafluoroethane, CF₃CH₂F)

[0228] HFC-134 (1,1,2,2-tetrafluoroethane, CHF₂CHF₂)

[0229] HFC-143a (1,1,1-trifluoroethane, CF₃CH₃)

[0230] HFC-143 (1,1,2-trifluoroethane, CHF₂CH₂F)

[0231] HFC-152a (1,1-difluoroethane, CHF₂CH₃)

[0232] HFC-152 (1,2-difluoroethane, CHF₂CHF₂F)

[0233] HFC-161 (fluoroethane, CH₃CH₂F)

[0234] HFC-245fa (1,1,1,3,3-pentafluoropropane, CF₃CH₂CHF₂)

[0235] HFC-236fa (1,1,1,3,3,3-hexafluoropropane, CF₃CH₂CF₃)

[0236] HFC-236ea (1,1,1,2,3,3-hexafluoropropane, CF₃CHFCHF₂)

[0237] HFC-227ea (1,1,1,2,3,3,3-heptafluoropropane, CF₃CHFCF₃)

[0238] HCFC-22 (chlorodifluoromethane, CHClF₂)

[0239] HCFC-31 (chlorofluoromethane, CH₂ClF)

[0240] CFC-1113 (chlorotrifluoroethylene, CF₂=CClF)

[0241] HFE-125 (trifluoromethyl-difluoromethyl ether, CF₃OCHF₂)

[0242] HFE-134a (trifluoromethyl-fluoromethyl ether, CF₃OCH₂F)

[0243] HFE-143a (trifluoromethyl-methyl ether, CF₃OCH₃)

[0244] HFE-227ea (trifluoromethyl-tetrafluoroethyl ether, CF₃OCHF₂CF₃)

[0245] HFE-236fa (trifluoromethyl-trifluoroethyl ether, CF₃OCH₂CF₃)

[0246] The tracer compound may be present in the refrigerant composition at a total concentration of about 10 parts per million (ppm) to about 1000 ppm. Preferably, the tracer compound is present in the refrigerant composition at a total concentration of about 30 ppm to about 500 ppm, and most preferably, the tracer compound is present at a total concentration of about 50 ppm to about 300 ppm.

(3-3) Ultraviolet Fluorescent Dye

[0247] The refrigerant composition according to the present disclosure may comprise a single ultraviolet fluorescent dye, or two or more ultraviolet fluorescent dyes.

[0248] The ultraviolet fluorescent dye is not limited, and can be suitably selected from commonly used ultraviolet fluorescent dyes.

[0249] Examples of ultraviolet fluorescent dyes include naphthalimide, coumarin, anthracene, phenanthrene, xanthene, thioxanthene, naphthoxanthene, fluorescein, and derivatives thereof. The ultraviolet fluorescent dye is particularly preferably either naphthalimide or coumarin, or both.

(3-4) Stabilizer

[0250] The refrigerant composition according to the present disclosure may comprise a single stabilizer, or two or more stabilizers.

[0251] The stabilizer is not limited, and can be suitably selected from commonly used stabilizers.

[0252] Examples of stabilizers include nitro compounds, ethers, and amines.

[0253] Examples of nitro compounds include aliphatic nitro compounds, such as nitromethane and nitroethane; and aromatic nitro compounds, such as nitro benzene and nitro styrene.

[0254] Examples of ethers include 1,4-dioxane.

[0255] Examples of amines include 2,2,3,3,3-pentafluoropropylamine and diphenylamine.

[0256] Examples of stabilizers also include butylhydroxyxylene and benzotriazole.

[0257] The content of the stabilizer is not limited. Generally, the content of the stabilizer is preferably 0.01 to 5 mass %, and more preferably 0.05 to 2 mass %, based on the entire refrigerant.

(3-5) Polymerization Inhibitor

[0258] The refrigerant composition according to the present disclosure may comprise a single polymerization inhibitor, or two or more polymerization inhibitors.

[0259] The polymerization inhibitor is not limited, and can be suitably selected from commonly used polymerization inhibitors.

[0260] Examples of polymerization inhibitors include 4-methoxy-1-naphthol, hydroquinone, hydroquinone methyl ether, dimethyl-t-butylphenol, 2,6-di-tert-butyl-p-cresol, and benzotriazole.

[0261] The content of the polymerization inhibitor is not limited. Generally, the content of the polymerization inhibitor is preferably 0.01 to 5 mass %, and more preferably 0.05 to 2 mass %, based on the entire refrigerant.

(4) Refrigeration Oil-Containing Working Fluid

[0262] The refrigeration oil-containing working fluid according to the present disclosure comprises at least the refrigerant or refrigerant composition according to the present disclosure and a refrigeration oil, for use as a working fluid in a refrigerating machine. Specifically, the refrigeration oil-containing working fluid according to the present disclosure is obtained by mixing a refrigeration oil used in a compressor of a refrigerating machine with the refrigerant or the refrigerant composition. The refrigeration oil-containing working fluid generally comprises 10 to 50 mass % of refrigeration oil.

(4-1) Refrigeration Oil

[0263] The refrigeration oil is not limited, and can be suitably selected from commonly used refrigeration oils. In this case, refrigeration oils that are superior in the action of increasing the miscibility with the mixture and the stability of the mixture, for example, are suitably selected as necessary.

[0264] The base oil of the refrigeration oil is preferably, for example, at least one member selected from the group consisting of polyalkylene glycols (PAG), polyol esters (POE), and polyvinyl ethers (PVE).

[0265] The refrigeration oil may further contain additives in addition to the base oil. The additive may be at least one member selected from the group consisting of antioxidants, extreme-pressure agents, acid scavengers, oxygen scavengers, copper deactivators, rust inhibitors, oil agents, and antifoaming agents.

[0266] A refrigeration oil with a kinematic viscosity of 5 to 400 cSt at 40° C. is preferable from the standpoint of lubrication.

[0267] The refrigeration oil-containing working fluid according to the present disclosure may further optionally contain at least one additive. Examples of additives include compatibilizing agents described below.

(4-2) Compatibilizing Agent

[0268] The refrigeration oil-containing working fluid according to the present disclosure may comprise a single compatibilizing agent, or two or more compatibilizing agents.

[0269] The compatibilizing agent is not limited, and can be suitably selected from commonly used compatibilizing agents.

[0270] Examples of compatibilizing agents include polyoxyalkylene glycol ethers, amides, nitriles, ketones, chlorocarbons, esters, lactones, aryl ethers, fluoroethers, and 1,1,1-trifluoroalkanes. The compatibilizing agent is particularly preferably a polyoxyalkylene glycol ether.

(5) Various Refrigerants

[0271] Hereinafter, the refrigerants A to E, which are the refrigerants used in the present embodiment, will be described in detail.

[0272] In addition, each description of the following refrigerant A, refrigerant B, refrigerant C, refrigerant D, and refrigerant E is each independent. The alphabet which shows a point or a line segment, the number of an Examples, and the number of a comparative examples are all independent of each other among the refrigerant A, the refrigerant B, the refrigerant C, the refrigerant D, and the refrigerant E. For example, the first embodiment of the refrigerant A and the first embodiment of the refrigerant B are different embodiment from each other.

(5-1) Refrigerant A

[0273] The refrigerant A according to the present disclosure is a mixed refrigerant comprising trans-1,2-difluoroethylene (HFO-1132(E)), trifluoroethylene (HFO-1123), and 2,3,3,3-tetrafluoro-1-propene (R1234yf).

[0274] The refrigerant A according to the present disclosure has various properties that are desirable as an R410A-alternative refrigerant, i.e., a refrigerating capacity and a

coefficient of performance that are equivalent to those of R410A, and a sufficiently low GWP.

[0275] The refrigerant A according to the present disclosure is a composition comprising HFO-1132(E) and R1234yf, and optionally further comprising HFO-1123, and may further satisfy the following requirements. This refrigerant also has various properties desirable as an alternative refrigerant for R410A; i.e., it has a refrigerating capacity and a coefficient of performance that are equivalent to those of R410A, and a sufficiently low GWP.

Requirements

[0276] Preferable refrigerant A is as follows:

[0277] When the mass % of HFO-1132(E), HFO-1123, and R1234yf based on their sum in the refrigerant is respectively represented by x, y, and z, coordinates (x,y,z) in a ternary composition diagram in which the sum of HFO-1132 (E), HFO-1123, and R1234yf is 100 mass % are within the range of a figure surrounded by line segments AA', A'B, BD, DC', C'C, CO, and OA that connect the following 7 points:
 point A (68.6, 0.0, 31.4),
 point A' (30.6, 30.0, 39.4),
 point B (0.0, 58.7, 41.3),
 point D (0.0, 80.4, 19.6),
 point C' (19.5, 70.5, 10.0),
 point C (32.9, 67.1, 0.0), and
 point O (100.0, 0.0, 0.0),

or on the above line segments (excluding the points on the line CO);

[0278] the line segment AA' is represented by coordinates (x, $0.0016x^2-0.9473x+57.497$, $-0.0016x^2-0.0527x+42.503$),

[0279] the line segment A'B is represented by coordinates (x, $0.0029x^2-1.0268x+58.7$, $-0.0029x^2+0.0268x+41.3$),

[0280] the line segment DC' is represented by coordinates (x, $0.0082x^2-0.6671x+80.4$, $-0.0082x^2-0.3329x+19.6$),

[0281] the line segment C'C is represented by coordinates (x, $0.0067x^2-0.6034x+79.729$, $-0.0067x^2-0.3966x+20.271$), and

[0282] the line segments BD, CO, and OA are straight lines.

[0283] When the requirements above are satisfied, the refrigerant according to the present disclosure has a refrigerating capacity ratio of 85% or more relative to that of R410A, and a COP of 92.5% or more relative to that of R410A.

[0284] When the mass % of HFO-1132(E), HFO-1123, and R1234yf, based on their sum in the refrigerant A according to the present disclosure is respectively represented by x, y, and z, the refrigerant is preferably a refrigerant wherein coordinates (x,y,z) in a ternary composition diagram in which the sum of HFO-1132(E), HFO-1123, and R1234yf is 100 mass % are within a figure surrounded by line segments GI, IA, AA', A'B, BD, DC', C'C, and CG that connect the following 8 points:

point G (72.0, 28.0, 0.0),
 point I (72.0, 0.0, 28.0),
 point A (68.6, 0.0, 31.4),
 point A' (30.6, 30.0, 39.4),
 point B (0.0, 58.7, 41.3),
 point D (0.0, 80.4, 19.6),
 point C' (19.5, 70.5, 10.0), and
 point C (32.9, 67.1, 0.0),

or on the above line segments (excluding the points on the line segment CG);

[0285] the line segment AA' is represented by coordinates (x, $0.0016x^2-0.9473x+57.497$, $-0.0016x^2-0.0527x+42.503$),

[0286] the line segment A'B is represented by coordinates (x, $0.0029x^2-1.0268x+58.7$, $-0.0029x^2+0.0268x+41.3$),

[0287] the line segment DC' is represented by coordinates (x, $0.0082x^2-0.6671x+80.4$, $-0.0082x^2-0.3329x+19.6$),

[0288] the line segment C'C is represented by coordinates (x, $0.0067x^2-0.6034x+79.729$, $-0.0067x^2-0.3966x+20.271$), and

[0289] the line segments GI, IA, BD, and CG are straight lines.

[0290] When the requirements above are satisfied, the refrigerant A according to the present disclosure has a refrigerating capacity ratio of 85% or more relative to that of R410A, and a COP of 92.5% or more relative to that of R410A; furthermore, the refrigerant A has a WCF lower flammability according to the ASHRAE Standard (the WCF composition has a burning velocity of 10 cm/s or less).

[0291] When the mass % of HFO-1132(E), HFO-1123, and R1234yf based on their sum in the refrigerant according to the present disclosure is respectively represented by x, y, and z, the refrigerant is preferably a refrigerant wherein coordinates (x,y,z) in a ternary composition diagram in which the sum of HFO-1132(E), HFO-1123, and R1234yf is 100 mass % are within the range of a figure surrounded by line segments JP, PN, NK, KA', A'B, BD, DC', C'C, and CJ that connect the following 9 points:

point J (47.1, 52.9, 0.0),
 point P (55.8, 42.0, 2.2),
 point N (68.6, 16.3, 15.1),
 point K (61.3, 5.4, 33.3),
 point A' (30.6, 30.0, 39.4),
 point B (0.0, 58.7, 41.3),
 point D (0.0, 80.4, 19.6),
 point C' (19.5, 70.5, 10.0), and
 point C (32.9, 67.1, 0.0),

or on the above line segments (excluding the points on the line segment CJ);

[0292] the line segment PN is represented by coordinates (x, $-0.1135x^2+12.112x-280.43$, $0.1135x^2-13.112x+380.43$),

[0293] the line segment NK is represented by coordinates (x, $0.2421x^2-29.955x+931.91$, $-0.2421x^2+28.955x-831.91$),

[0294] the line segment KA' is represented by coordinates (x, $0.0016x^2-0.9473x+57.497$, $-0.0016x^2-0.0527x+42.503$),

[0295] the line segment A'B is represented by coordinates (x, $0.0029x^2-1.0268x+58.7$, $-0.0029x^2+0.0268x+41.3$),

[0296] the line segment DC' is represented by coordinates (x, $0.0082x^2-0.6671x+80.4$, $-0.0082x^2-0.3329x+19.6$),

[0297] the line segment C'C is represented by coordinates (x, $0.0067x^2-0.6034x+79.729$, $-0.0067x^2-0.3966x+20.271$), and

[0298] the line segments JP, BD, and CG are straight lines.

[0299] When the requirements above are satisfied, the refrigerant A according to the present disclosure has a refrigerating capacity ratio of 85% or more relative to that of R410A, and a COP of 92.5% or more relative to that of R410A; furthermore, the refrigerant exhibits a lower flammability (Class 2L) according to the ASHRAE Standard (the

WCF composition and the WCF composition have a burning velocity of 10 cm/s or less).

[0300] When the mass % of HFO-1132(E), HFO-1123, and R1234yf based on their sum in the refrigerant according to the present disclosure is respectively represented by x, y, and z, the refrigerant is preferably a refrigerant wherein coordinates (x,y,z) in a ternary composition diagram in which the sum of HFO-1132(E), HFO-1123, and R1234yf is 100 mass % are within the range of a figure surrounded by line segments JP, PL, LM, MA', A'B, BD, DC', C' C, and CJ that connect the following 9 points:

point J (47.1, 52.9, 0.0),
point P (55.8, 42.0, 2.2),
point L (63.1, 31.9, 5.0),
point M (60.3, 6.2, 33.5),
point A' (30.6, 30.0, 39.4),
point B (0.0, 58.7, 41.3),
point D (0.0, 80.4, 19.6),
point C' (19.5, 70.5, 10.0), and
point (32.9, 67.1, 0.0),

or on the above line segments (excluding the points on the line segment CJ);

[0301] the line segment PL is represented by coordinates (x, $-0.1135x^2+12.112x-280.43$, $0.1135x^2-13.112x+380.43$),

[0302] the line segment MA' is represented by coordinates (x, $0.0016x^2-0.9473x+57.497$, $-0.0016x^2-0.0527x+42.503$),

[0303] the line segment A'B is represented by coordinates (x, $0.0029x^2-1.0268x+58.7$, $-0.0029x^2+0.0268x+41.3$),

[0304] the line segment DC' is represented by coordinates (x, $0.0082x^2-0.6671x+80.4$, $-0.0082x^2-0.3329x+19.6$),

[0305] the line segment C'C is represented by coordinates (x, $0.0067x^2-0.6034x+79.729$, $-0.0067x^2-0.3966x+20.271$), and

[0306] the line segments JP, LM, BD, and CG are straight lines.

[0307] When the requirements above are satisfied, the refrigerant according to the present disclosure has a refrigerating capacity ratio of 85% or more relative to that of R410A, and a COP of 92.5% or more relative to that of R410A; furthermore, the refrigerant has an RCL of 40 g/m³ or more.

[0308] When the mass % of HFO-1132(E), HFO-1123, and R1234yf based on their sum in the refrigerant A according to the present disclosure is respectively represented by x, y, and z, the refrigerant is preferably a refrigerant wherein coordinates (x,y,z) in a ternary composition diagram in which the sum of HFO-1132(E), HFO-1123, and R1234yf is 100 mass % are within the range of a figure surrounded by line segments PL, LM, MA', A'B, BF, FT, and TP that connect the following 7 points:

point P (55.8, 42.0, 2.2),
point L (63.1, 31.9, 5.0),
point M (60.3, 6.2, 33.5),
point A' (30.6, 30.0, 39.4),
point B (0.0, 58.7, 41.3),
point F (0.0, 61.8, 38.2), and
point T (35.8, 44.9, 19.3),

or on the above line segments (excluding the points on the line segment BF);

[0309] the line segment PL is represented by coordinates (x, $-0.1135x^2+12.112x-280.43$, $0.1135x^2-13.112x+380.43$),

[0310] the line segment MA' is represented by coordinates (x, $0.0016x^2-0.9473x+57.497$, $-0.0016x^2-0.0527x+42.503$),

[0311] the line segment A'B is represented by coordinates (x, $0.0029x^2-1.0268x+58.7$, $-0.0029x^2+0.0268x+41.3$),

[0312] the line segment FT is represented by coordinates (x, $0.0078x^2-0.7501x+61.8$, $-0.0078x^2-0.2499x+38.2$),

[0313] the line segment TP is represented by coordinates (x, $0.00672x^2-0.7607x+63.525$, $-0.00672x^2-0.2393x+36.475$), and

[0314] the line segments LM and BF are straight lines.

[0315] When the requirements above are satisfied, the refrigerant according to the present disclosure has a refrigerating capacity ratio of 85% or more relative to that of R410A, and a COP of 95% or more relative to that of R410A; furthermore, the refrigerant has an RCL of 40 g/m³ or more.

[0316] The refrigerant A according to the present disclosure is preferably a refrigerant wherein when the mass % of HFO-1132(E), HFO-1123, and R1234yf based on their sum in the refrigerant is respectively represented by x, y, and z, coordinates (x,y,z) in a ternary composition diagram in which the sum of HFO-1132(E), HFO-1123, and R1234yf is 100 mass % are within the range of a figure surrounded by line segments PL, LQ, QR, and RP that connect the following 4 points:

point P (55.8, 42.0, 2.2),
point L (63.1, 31.9, 5.0),
point Q (62.8, 29.6, 7.6), and
point R (49.8, 42.3, 7.9),

or on the above line segments;

[0317] the line segment PL is represented by coordinates (x, $-0.1135x^2+12.112x-280.43$, $0.1135x^2-13.112x+380.43$),

[0318] the line segment RP is represented by coordinates (x, $0.00672x^2-0.7607x+63.525$, $-0.00672x^2-0.2393x+36.475$), and

[0319] the line segments LQ and QR are straight lines.

[0320] When the requirements above are satisfied, the refrigerant according to the present disclosure has a COP of 95% or more relative to that of R410A, and an RCL of 40 g/m³ or more, furthermore, the refrigerant has a condensation temperature glide of 1° C. or less.

[0321] The refrigerant A according to the present disclosure is preferably a refrigerant wherein when the mass % of HFO-1132(E), HFO-1123, and R1234yf based on their sum in the refrigerant is respectively represented by x, y, and z, coordinates (x,y,z) in a ternary composition diagram in which the sum of HFO-1132(E), HFO-1123, and R1234yf is 100 mass % are within the range of a figure surrounded by line segments SM, MA', A'B, BF, FT, and TS that connect the following 6 points:

point S (62.6, 28.3, 9.1),
point M (60.3, 6.2, 33.5),
point A' (30.6, 30.0, 39.4),
point B (0.0, 58.7, 41.3),
point F (0.0, 61.8, 38.2), and
point T (35.8, 44.9, 19.3),

or on the above line segments,

[0322] the line segment MA' is represented by coordinates (x, $0.0016x^2-0.9473x+57.497$, $-0.0016x^2-0.0527x+42.503$),

[0323] the line segment A'B is represented by coordinates (x, $0.0029x^2-1.0268x+58.7$, $-0.0029x^2+0.0268x+41.3$),

[0324] the line segment FT is represented by coordinates $(x, 0.0078x^2 - 0.7501x + 61.8, -0.0078x^2 - 0.2499x + 38.2)$,

[0325] the line segment TS is represented by coordinates $(x, -0.0017x^2 - 0.7869x + 70.888, -0.0017x^2 - 0.2131x + 29.112)$, and

[0326] the line segments SM and BF are straight lines.

[0327] When the requirements above are satisfied, the refrigerant according to the present disclosure has a refrigerating capacity ratio of 85% or more relative to that of R410A, a COP of 95% or more relative to that of R410A, and an RCL of 40 g/m³ or more furthermore, the refrigerant has a discharge pressure of 105% or more relative to that of R410A.

[0328] The refrigerant A according to the present disclosure is preferably a refrigerant wherein when the mass % of HFO-1132(E), HFO-1123, and R1234yf based on their sum in the refrigerant is respectively represented by x, y, and z, coordinates (x,y,z) in a ternary composition diagram in which the sum of HFO-1132(E), HFO-1123, and R1234yf is 100 mass % are within the range of a figure surrounded by line segments Od, dg, gh, and hO that connect the following 4 points:

point d (87.6, 0.0, 12.4),

point g (18.2, 55.1, 26.7),

point h (56.7, 43.3, 0.0), and

point o (100.0, 0.0, 0.0),

or on the line segments Od, dg, gh, and hO (excluding the points O and h);

[0329] the line segment dg is represented by coordinates $(0.0047y^2 - 1.5177y + 87.598, y, -0.0047y^2 + 0.5177y + 12.402)$,

[0330] the line segment gh is represented by coordinates $(-0.0134z^2 - 1.0825z + 56.692, 0.0134z^2 + 0.0825z + 43.308, z)$, and

[0331] the line segments hO and Od are straight lines.

[0332] When the requirements above are satisfied, the refrigerant according to the present disclosure has a refrigerating capacity ratio of 92.5% or more relative to that of R410A, and a COP ratio of 92.5% or more relative to that of R410A.

[0333] The refrigerant A according to the present disclosure is preferably a refrigerant wherein when the mass % of HFO-1132(E), HFO-1123, and R1234yf, based on their sum is respectively represented by x, y, and z, coordinates (x,y,z) in a ternary composition diagram in which the sum of HFO-1132(E), HFO-1123, and R1234yf is 100 mass % are within the range of a figure surrounded by line segments lg, gh, hi, and it that connect the following 4 points:

point l (72.5, 10.2, 17.3),

point g (18.2, 55.1, 26.7),

point h (56.7, 43.3, 0.0), and

point i (72.5, 27.5, 0.0) or

on the line segments lg, gh, and il (excluding the points h and i);

[0334] the line segment lg is represented by coordinates $(0.0047y^2 - 1.5177y + 87.598, y, -0.0047y^2 + 0.5177y + 12.402)$,

[0335] the line gh is represented by coordinates $(-0.0134z^2 - 1.0825z + 56.692, 0.0134z^2 + 0.0825z + 43.308, z)$, and

[0336] the line segments hi and il are straight lines.

[0337] When the requirements above are satisfied, the refrigerant according to the present disclosure has a refrigerating capacity ratio of 92.5% or more relative to that of

R410A, and a COP ratio of 92.5% or more relative to that of R410A; furthermore, the refrigerant has a lower flammability (Class 2L) according to the ASHRAE Standard.

[0338] The refrigerant A according to the present disclosure is preferably a refrigerant wherein

[0339] when the mass % of HFO-1132(E), HFO-1123, and R1234yf based on their sum is respectively represented by x, y, and z, coordinates (x,y,z) in a ternary composition diagram in which the sum of HFO-1132(E), HFO-1123, and R1234yf is 100 mass % are within the range of a figure surrounded by line segments Od, de, ef, and fO that connect the following 4 points:

point d (87.6, 0.0, 12.4),

point e (31.1, 42.9, 26.0),

point f (65.5, 34.5, 0.0), and

point O (100.0, 0.0, 0.0),

or on the line segments Od, de, and ef (excluding the points O and f);

[0340] the line segment de is represented by coordinates $(0.0047y^2 - 1.5177y + 87.598, y, -0.0047y^2 + 0.5177y + 12.402)$,

[0341] the line segment ef is represented by coordinates $(-0.0064z^2 - 1.1565z + 65.501, 0.0064z^2 + 0.1565z + 34.499, z)$, and

[0342] the line segments fO and Od are straight lines.

[0343] When the requirements above are satisfied, the refrigerant according to the present disclosure has a refrigerating capacity ratio of 93.5% or more relative to that of R410A, and a COP ratio of 93.5% or more relative to that of R410A.

[0344] The refrigerant A according to the present disclosure is preferably a refrigerant wherein

[0345] when the mass % of HFO-1132(E), HFO-1123, and R1234yf based on their sum is respectively represented by x, y, and z,

[0346] coordinates (x,y,z) in a ternary composition diagram in which the sum of HFO-1132(E), HFO-1123, and R1234yf is 100 mass % are within the range of a figure surrounded by line segments le, ef, fi, and il that connect the following 4 points:

point l (72.5, 10.2, 17.3),

point e (31.1, 42.9, 26.0),

point f (65.5, 34.5, 0.0), and

point i (72.5, 27.5, 0.0),

or on the line segments le, ef, and il (excluding the points f and i);

[0347] the line segment le is represented by coordinates $(0.0047y^2 - 1.5177y + 87.598, y, -0.0047y^2 + 0.5177y + 12.402)$,

[0348] the line segment of is represented by coordinates $(-0.0134z^2 - 1.0825z + 56.692, 0.0134z^2 + 0.0825z + 43.308, z)$, and

[0349] the line segments fi and it are straight lines.

[0350] When the requirements above are satisfied, the refrigerant according to the present disclosure has a refrigerating capacity ratio of 93.5% or more relative to that of R410A, and a COP ratio of 93.5% or more relative to that of R410A; furthermore, the refrigerant has a lower flammability (Class 2L) according to the ASHRAE Standard.

[0351] The refrigerant A according to the present disclosure is preferably a refrigerant wherein

[0352] when the mass % of HFO-1132(E), HFO-1123, and R1234yf based on their sum is respectively represented by x, y, and z,

[0353] coordinates (x,y,z) in a ternary composition diagram in which the sum of HFO-1132(E), HFO-1123, and R1234yf is 100 mass % are within the range of a figure surrounded by line segments Oa, ab, bc, and cO that connect the following 4 points:

- point a (93.4, 0.0, 6.6),
- point b (55.6, 26.6, 17.8),
- point c (77.6, 22.4, 0.0), and
- point O (100.0, 0.0, 0.0),

or on the line segments Oa, ab, and bc (excluding the points O and c);

[0354] the line segment ab is represented by coordinates $(0.0052y^2 - 1.5588y + 93.385, y, -0.0052y^2 + 0.5588y + 6.615)$,

[0355] the line segment bc is represented by coordinates $(-0.0032z^2 - 1.1791z + 77.593, 0.0032z^2 + 0.1791z + 22.407, z)$, and

[0356] the line segments cO and Oa are straight lines.

[0357] When the requirements above are satisfied, the refrigerant according to the present disclosure has a refrigerating capacity ratio of 95% or more relative to that of R410A, and a COP ratio of 95% or more relative to that of R410A.

[0358] The refrigerant A according to the present disclosure is preferably a refrigerant wherein

[0359] when the mass % of HFO-1132(E), HFO-1123, and R1234yf based on their sum is respectively represented by x, y, and z,

[0360] coordinates (x,y,z) in a ternary composition diagram in which the sum of HFO-1132(E), HFO-1123, and R1234yf is 100 mass % are within the range of a figure surrounded by line segments kb, bj, and jk that connect the following 3 points:

- point k (72.5, 14.1, 13.4),
- point b (55.6, 26.6, 17.8), and
- point j (72.5, 23.2, 4.3),

or on the line segments kb, bj, and jk;

[0361] the line segment kb is represented by coordinates $(0.0052y^2 - 1.5588y + 93.385, y, -0.0052y^2 + 0.5588y + 6.615)$,

[0362] the line segment bj is represented by coordinates $(-0.0032z^2 - 1.1791z + 77.593, 0.0032z^2 + 0.1791z + 22.407, z)$, and

[0363] the line segment jk is a straight line.

[0364] When the requirements above are satisfied, the refrigerant according to the present disclosure has a refrigerating capacity ratio of 95% or more relative to that of R410A, and a COP ratio of 95% or more relative to that of R410A; furthermore, the refrigerant has a lower flammability (Class 2L) according to the ASHRAE Standard.

[0365] The refrigerant according to the present disclosure may further comprise other additional refrigerants in addition to HFO-1132(E), HFO-1123, and R1234yf, as long as the above properties and effects are not impaired. In this respect, the refrigerant according to the present disclosure preferably comprises HFO-1132(E), HFO-1123, and R1234yf in a total amount of 99.5 mass % or more, more preferably 99.75 mass % or more, and still more preferably 99.9 mass % or more, based on the entire refrigerant.

[0366] The refrigerant according to the present disclosure may comprise HFO-1132(E), HFO-1123, and R1234yf in a total amount of 99.5 mass % or more, 99.75 mass % or more, or 99.9 mass % or more, based on the entire refrigerant.

[0367] Additional refrigerants are not particularly limited and can be widely selected. The mixed refrigerant may contain one additional refrigerant, or two or more additional refrigerants.

(Examples of Refrigerant A)

[0368] The present disclosure is described in more detail below with reference to Examples of refrigerant A. However, refrigerant A is not limited to the Examples.

[0369] The GWP of R1234yf and a composition consisting of a mixed refrigerant R410A (R32=50%/R125=50%) was evaluated based on the values stated in the Intergovernmental Panel on Climate Change (IPCC), fourth report. The GWP of HFO-1132(E), which was not stated therein, was assumed to be 1 from HFO-1132a (GWP=1 or less) and HFO-1123 (GWP=0.3, described in Patent Literature 1). The refrigerating capacity of R410A and compositions each comprising a mixture of HFO-1132(E), HFO-1123, and R1234yf was determined by performing theoretical refrigeration cycle calculations for the mixed refrigerants using the National Institute of Science and Technology (NIST) and Reference Fluid Thermodynamic and Transport Properties Database (Refprop 9.0) under the following conditions.

[0370] Further, the RCL of the mixture was calculated with the LFL of HFO-1132(E) being 4.7 vol. %, the LFL of HFO-1123 being 10 vol. %, and the LFL of R1234yf being 6.2 vol. %, in accordance with the ASHRAE Standard 34-2013.

Evaporating temperature: 5° C.

Condensation temperature: 45° C.

Degree of superheating: 5 K

Degree of subcooling: 5 K

Compressor efficiency: 70%

[0371] Tables 1 to 34 show these values together with the GWP of each mixed refrigerant.

TABLE 1

Item	Unit	Comp.	Comp.	Comp.	Exam-	Exam-	Comp.	
		Ex. 1	Ex. 2	Ex. 3	ple 1	ple 2	Ex. 4	
			O	A	A'	A'	B	
HFO-1132(E)	mass %	R410A	100.0	68.6	49.0	30.6	14.1	0.0
HFO-1123	mass %		0.0	0.0	14.9	30.0	44.8	58.7
R1234yf	mass %		0.0	31.4	36.1	39.4	41.1	41.3
GWP	—	2088	1	2	2	2	2	2
COP ratio	% (relative to 410A)	100	99.7	100.0	98.6	97.3	96.3	95.5
Refrigerating capacity ratio	% (relative to 410A)	100	98.3	85.0	85.0	85.0	85.0	85.0
Condensation glide	° C.	0.1	0.00	1.98	3.36	4.46	5.15	5.35

TABLE 1-continued

Item	Unit	Comp.	Comp.	Comp.	Exam-	Exam-	Comp.	
		Ex. 1	Ex. 2 O	Ex. 3 A	Exam- ple 1	ple 2 A'	Exam- ple 3	Ex. 4 B
Discharge pressure	% (relative to 410A)	100.0	99.3	87.1	88.9	90.6	92.1	93.2
RCL	g/m ³	—	30.7	37.5	44.0	52.7	64.0	78.6

TABLE 2

Item	Unit	Comp.	Exam-	Exam-	Exam-	Comp.	Comp.	Exam-	Comp.
		Ex. 5 C	Exam- ple 4	ple 5 C'	Exam- ple 6	Ex. 6 D	Ex. 7 E	Exam- ple 7 E'	Ex. 8 F
HFO-1132(E)	mass %	32.9	26.6	19.5	10.9	0.0	58.0	23.4	0.0
HFO-1123	mass %	67.1	68.4	70.5	74.1	80.4	42.0	48.5	61.8
R1234yf	mass %	0.0	5.0	10.0	15.0	19.6	0.0	28.1	38.2
GWP	—	1	1	1	1	2	1	2	2
COP ratio	% (relative to 410A)	92.5	92.5	92.5	92.5	92.5	95.0	95.0	95.0
Refrigerating capacity ratio	% (relative to 410A)	107.4	105.2	102.9	100.5	97.9	105.0	92.5	86.9
Condensation glide	° C.	0.16	0.52	0.94	1.42	1.90	0.42	3.16	4.80
Discharge pressure	% (relative to 410A)	119.5	117.4	115.3	113.0	115.9	112.7	101.0	95.8
RCL	g/m ³	53.5	57.1	62.0	69.1	81.3	41.9	46.3	79.0

TABLE 3

Item	Unit	Comp.	Exam-	Exam-	Exam-	Exam-	Exam-
		Ex. 9 J	Exam- ple 8 P	ple 9 L	Exam- ple 10 N	Exam- ple 11 N'	Exam- ple 12 K
HFO-1132(E)	mass %	47.1	55.8	63.1	68.6	65.0	61.3
HFO-1123	mass %	52.9	42.0	31.9	16.3	7.7	5.4
R1234yf	mass %	0.0	2.2	5.0	15.1	27.3	33.3
GWP	—	1	1	1	1	2	2
COP ratio	% (relative to 410A)	93.8	95.0	96.1	97.9	99.1	99.5
Refrigerating capacity ratio	% (relative to 410A)	106.2	104.1	101.6	95.0	88.2	85.0
Condensation glide	° C.	0.31	0.57	0.81	1.41	2.11	2.51
Discharge pressure	% (relative to 410A)	115.8	111.9	107.8	99.0	91.2	87.7
RCL	g/m ³	46.2	42.6	40.0	38.0	38.7	39.7

TABLE 4

Item	Unit	Exam-	Exam-	Exam-	Exam-	Exam-	Exam-	Exam-
		Example 13 L	Example 14 M	Example 15 Q	Example 16 R	Example 17 S	Example 18 S'	Example 19 T
HFO-1132(E)	mass %	63.1	60.3	62.8	49.8	62.6	50.0	35.8
HFO-1123	mass %	31.9	6.2	29.6	42.3	28.3	35.8	44.9
R1234yf	mass %	5.0	33.5	7.6	7.9	9.1	14.2	19.3
GWP	—	1	2	1	1	1	1	2
COP ratio	% (relative to 410A)	96.1	99.4	96.4	95.0	96.6	95.8	95.0
Refrigerating capacity ratio	% (relative to 410A)	101.6	85.0	100.2	101.7	99.4	98.1	96.7
Condensation glide	° C.	0.81	2.58	1.00	1.00	1.10	1.55	2.07
Discharge pressure	% (relative to 410A)	107.8	87.9	106.0	109.6	105.0	105.0	105.0
RCL	g/m ³	40.0	40.0	40.0	44.8	40.0	44.4	50.8

TABLE 5

Item	Unit	Comp. Ex. 10 G	Example 20 H	Example 21 I
HFO-1132(E)	mass %	72.0	72.0	72.0
HFO-1123	mass %	28.0	14.0	0.0
R1234yf	mass %	0.0	14.0	28.0
GWP	—	1	1	2
COP ratio	% (relative to 410A)	96.6	98.2	99.9

TABLE 5-continued

Item	Unit	Comp. Ex. 10 G	Example 20 H	Example 21 I
Refrigerating capacity ratio	% (relative to 410A)	103.1	95.1	86.6
Condensation glide	° C.	0.46	1.27	1.71
Discharge pressure	% (relative to 410A)	108.4	98.7	88.6
RCL	g/m ³	37.4	37.0	36.6

TABLE 6

Item	Unit	Comp. Ex. 11	Comp. Ex. 12	Example 22	Example 23	Example 24	Example 25	Example 26	Comp. Ex. 13
HFO-1132(E)	mass %	10.0	20.0	30.0	40.0	50.0	60.0	70.0	80.0
HFO-1123	mass %	85.0	75.0	65.0	55.0	45.0	35.0	25.0	15.0
R1234yf	mass %	5.0	5.0	5.0	5.0	5.0	5.0	5.0	5.0
GWP	—	1	1	1	1	1	1	1	1
COP ratio	% (relative to 410A)	91.4	92.0	92.8	93.7	94.7	95.8	96.9	98.0
Refrigerating capacity ratio	% (relative to 410A)	105.7	105.5	105.0	104.3	103.3	102.0	100.6	99.1
Condensation glide	° C.	0.40	0.46	0.55	0.66	0.75	0.80	0.79	0.67
Discharge pressure	% (relative to 410A)	120.1	118.7	116.7	114.3	111.6	108.7	105.6	102.5
RCL	g/m ³	71.0	61.9	54.9	49.3	44.8	41.0	37.8	35.1

TABLE 7

Item	Unit	Comp. Ex. 14	Example 27	Example 28	Example 29	Example 30	Example 31	Example 32	Comp. Ex. 15
HFO-1132(E)	mass %	10.0	20.0	30.0	40.0	50.0	60.0	70.0	80.0
HFO-1123	mass %	80.0	70.0	60.0	50.0	40.0	30.0	20.0	10.0
R1234yf	mass %	10.0	10.0	10.0	10.0	10.0	10.0	10.0	10.0
GWP	—	1	1	1	1	1	1	1	1
COP ratio	% (relative to 410A)	91.9	92.5	93.3	94.3	95.3	96.4	97.5	98.6
Refrigerating capacity ratio	% (relative to 410A)	103.2	102.9	102.4	101.5	100.5	99.2	97.8	96.2
Condensation glide	° C.	0.87	0.94	1.03	1.12	1.18	1.18	1.09	0.88
Discharge pressure	% (relative to 410A)	116.7	115.2	113.2	110.8	108.1	105.2	102.1	99.0
RCL	g/m ³	70.5	61.6	54.6	49.1	44.6	40.8	37.7	35.0

TABLE 8

Item	Unit	Comp. Ex. 16	Example 33	Example 34	Example 35	Example 36	Example 37	Example 38	Comp. Ex. 17
HFO-1132(E)	mass %	10.0	20.0	30.0	40.0	50.0	60.0	70.0	80.0
HFO-1123	mass %	75.0	65.0	55.0	45.0	35.0	25.0	15.0	5.0
R1234yf	mass %	15.0	15.0	15.0	15.0	15.0	15.0	15.0	15.0
GWP	—	1	1	1	1	1	1	1	1
COP ratio	% (relative to 410A)	92.4	93.1	93.9	94.8	95.9	97.0	98.1	99.2
Refrigerating capacity ratio	% (relative to 410A)	100.5	100.2	99.6	98.7	97.7	96.4	94.9	93.2
Condensation glide	° C.	1.41	1.49	1.56	1.62	1.63	1.55	1.37	1.05
Discharge pressure	% (relative to 410A)	113.1	111.6	109.6	107.2	104.5	101.6	98.6	95.5
RCL	g/m ³	70.0	61.2	54.4	48.9	44.4	40.7	37.5	34.8

TABLE 9

Item	Unit	Example 39	Example 40	Example 41	Example 42	Example 43	Example 44	Example 45
HFO-1132(E)	mass %	10.0	20.0	30.0	40.0	50.0	60.0	70.0
HFO-1123	mass %	70.0	60.0	50.0	40.0	30.0	20.0	10.0
R1234yf	mass %	20.0	20.0	20.0	20.0	20.0	20.0	20.0
GWP	—	2	2	2	2	2	2	2
COP ratio	% (relative to 410A)	93.0	93.7	94.5	95.5	96.5	97.6	98.7
Refrigerating capacity ratio	% (relative to 410A)	97.7	97.4	96.8	95.9	94.7	93.4	91.9
Condensation glide	° C.	2.03	2.09	2.13	2.14	2.07	1.91	1.61
Discharge pressure	% (relative to 410A)	109.4	107.9	105.9	103.5	100.8	98.0	95.0
RCL	g/m ³	69.6	60.9	54.1	48.7	44.2	40.5	37.4

TABLE 10

Item	Unit	Example 46	Example 47	Example 48	Example 49	Example 50	Example 51	Example 52
HFO-1132(E)	mass %	10.0	20.0	30.0	40.0	50.0	60.0	70.0
HFO-1123	mass %	65.0	55.0	45.0	35.0	25.0	15.0	5.0
R1234yf	mass %	25.0	25.0	25.0	25.0	25.0	25.0	25.0
GWP	—	2	2	2	2	2	2	2
COP ratio	% (relative to 410A)	93.6	94.3	95.2	96.1	97.2	98.2	99.3
Refrigerating capacity ratio	% (relative to 410A)	94.8	94.5	93.8	92.9	91.8	90.4	88.8
Condensation glide	° C.	2.71	2.74	2.73	2.66	2.50	2.22	1.78
Discharge pressure	% (relative to 410A)	105.5	104.0	102.1	99.7	97.1	94.3	91.4
RCL	g/m ³	69.1	60.5	53.8	48.4	44.0	40.4	37.3

TABLE 11

Item	Unit	Example 53	Example 54	Example 55	Example 56	Example 57	Example 58
HFO-1132(E)	mass %	10.0	20.0	30.0	40.0	50.0	60.0
HFO-1123	mass %	60.0	50.0	40.0	30.0	20.0	10.0
R1234yf	mass %	30.0	30.0	30.0	30.0	30.0	30.0
GWP	—	2	2	2	2	2	2
COP ratio	% (relative to 410A)	94.3	95.0	95.9	96.8	97.8	98.9
Refrigerating capacity ratio	% (relative to 410A)	91.9	91.5	90.8	89.9	88.7	87.3
Condensation glide	° C.	3.46	3.43	3.35	3.18	2.90	2.47
Discharge pressure	% (relative to 410A)	101.6	100.1	98.2	95.9	93.3	90.6
RCL	g/m ³	68.7	60.2	53.5	48.2	43.9	40.2

TABLE 12

Item	Unit	Example 59	Example 60	Example 61	Example 62	Example 63	Comp. Ex. 18
HFO-1132(E)	mass %	10.0	20.0	30.0	40.0	50.0	60.0
HFO-1123	mass %	55.0	45.0	35.0	25.0	15.0	5.0
R1234yf	mass %	35.0	35.0	35.0	35.0	35.0	35.0
GWP	—	2	2	2	2	2	2
COP ratio	% (relative to 410A)	95.0	95.8	96.6	97.5	98.5	99.6
Refrigerating capacity ratio	% (relative to 410A)	88.9	88.5	87.8	86.8	85.6	84.1
Condensation glide	° C.	4.24	4.15	3.96	3.67	3.24	2.64

TABLE 12-continued

Item	Unit	Exam- ple 59	Exam- ple 60	Exam- ple 61	Exam- ple 62	Exam- ple 63	Comp. Ex. 18
Discharge pressure	% (relative to 410A)	97.6	96.1	94.2	92.0	89.5	86.8
RCL	g/m ³	68.2	59.8	53.2	48.0	43.7	40.1

TABLE 13

Item	Unit	Exam- ple 64	Exam- ple 65	Comp. Ex. 19	Comp. Ex. 20	Comp. Ex. 21
HFO-1132(E)	mass %	10.0	20.0	30.0	40.0	50.0
HFO-1123	mass %	50.0	40.0	30.0	20.0	10.0
R1234yf	mass %	40.0	40.0	40.0	40.0	40.0
GWP	—	2	2	2	2	2
COP ratio	% (relative to 410A)	95.9	96.6	97.4	98.3	99.2
Refrigerating capacity ratio	% (relative to 410A)	85.8	85.4	84.7	83.6	82.4
Condensation glide	° C.	5.05	4.85	4.55	4.10	3.50
Discharge pressure	% (relative to 410A)	93.5	92.1	90.3	88.1	85.6
RCL	g/m ³	67.8	59.5	53.0	47.8	43.5

TABLE 14

Item	Unit	Exam- ple 66	Exam- ple 67	Exam- ple 68	Exam- ple 69	Exam- ple 70	Exam- ple 71	Exam- ple 72	Exam- ple 73
HFO-1132(E)	mass %	54.0	56.0	58.0	62.0	52.0	54.0	56.0	58.0
HFO-1123	mass %	41.0	39.0	37.0	33.0	41.0	39.0	37.0	35.0
R1234yf	mass %	5.0	5.0	5.0	5.0	7.0	7.0	7.0	7.0
GWP	—	1	1	1	1	1	1	1	1
COP ratio	% (relative to 410A)	95.1	95.3	95.6	96.0	95.1	95.4	95.6	95.8
Refrigerating capacity ratio	% (relative to 410A)	102.8	102.6	102.3	101.8	101.9	101.7	101.5	101.2
Condensation glide	° C.	0.78	0.79	0.80	0.81	0.93	0.94	0.95	0.95
Discharge pressure	% (relative to 410A)	110.5	109.9	109.3	108.1	109.7	109.1	108.5	107.9
RCL	g/m ³	43.2	42.4	41.7	40.3	43.9	43.1	42.4	41.6

TABLE 15

Item	Unit	Exam- ple 74	Exam- ple 75	Exam- ple 76	Exam- ple 77	Exam- ple 78	Exam- ple 79	Exam- ple 80	Exam- ple 81
HFO-1132(E)	mass %	60.0	62.0	61.0	58.0	60.0	62.0	52.0	54.0
HFO-1123	mass %	33.0	31.0	29.0	30.0	28.0	26.0	34.0	32.0
R1234yf	mass %	7.0	7.0	10.0	12.0	12.0	12.0	14.0	14.0
GWP	—	1	1	1	1	1	1	1	1
COP ratio	% (relative to 410A)	96.0	96.2	96.5	96.4	96.6	96.8	96.0	96.2
Refrigerating capacity ratio	% (relative to 410A)	100.9	100.7	99.1	98.4	98.1	97.8	98.0	97.7
Condensation glide	° C.	0.95	0.95	1.18	1.34	1.33	1.32	1.53	1.53
Discharge pressure	% (relative to 410A)	107.3	106.7	104.9	104.4	103.8	103.2	104.7	104.1
RCL	g/m ³	40.9	40.3	40.5	41.5	40.8	40.1	43.6	42.9

TABLE 16

Item	Unit	Example 82	Example 83	Example 84	Example 85	Example 86	Example 87	Example 88	Example 89
HFO-1132(E)	mass %	56.0	58.0	60.0	48.0	50.0	52.0	54.0	56.0
HFO-1123	mass %	30.0	28.0	26.0	36.0	34.0	32.0	30.0	28.0
R1234yf	mass %	14.0	14.0	14.0	16.0	16.0	16.0	16.0	16.0
GWP	—	1	1	1	1	1	1	1	1
COP ratio	% (relative to 410A)	96.4	96.6	96.9	95.8	96.0	96.2	96.4	96.7
Refrigerating capacity ratio	% (relative to 410A)	97.5	97.2	96.9	97.3	97.1	96.8	96.6	96.3
Condensation glide	° C.	1.51	1.50	1.48	1.72	1.72	1.71	1.69	1.67
Discharge pressure	% (relative to 410A)	103.5	102.9	102.3	104.3	103.8	103.2	102.7	102.1
RCL	g/m ³	42.1	41.4	40.7	45.2	44.4	43.6	42.8	42.1

TABLE 17

Item	Unit	Example 90	Example 91	Example 92	Example 93	Example 94	Example 95	Example 96	Example 97
HFO-1132(E)	mass %	58.0	60.0	42.0	44.0	46.0	48.0	50.0	52.0
HFO-1123	mass %	26.0	24.0	40.0	38.0	36.0	34.0	32.0	30.0
R1234yf	mass %	16.0	16.0	18.0	18.0	18.0	18.0	18.0	18.0
GWP	—	1	1	2	2	2	2	2	2
COP ratio	% (relative to 410A)	96.9	97.1	95.4	95.6	95.8	96.0	96.3	96.5
Refrigerating capacity ratio	% (relative to 410A)	96.1	95.8	96.8	96.6	96.4	96.2	95.9	95.7
Condensation glide	° C.	1.65	1.63	1.93	1.92	1.92	1.91	1.89	1.88
Discharge pressure	% (relative to 410A)	101.5	100.9	104.5	103.9	103.4	102.9	102.3	101.8
RCL	g/m ³	41.4	40.7	47.8	46.9	46.0	45.1	44.3	43.5

TABLE 18

Item	Unit	Example 98	Example 99	Example 100	Example 101	Example 102	Example 103	Example 104	Example 105
HFO-1132(E)	mass %	54.0	56.0	58.0	60.0	36.0	38.0	42.0	44.0
HFO-1123	mass %	28.0	26.0	24.0	22.0	44.0	42.0	38.0	36.0
R1234yf	mass %	18.0	18.0	18.0	18.0	20.0	20.0	20.0	20.0
GWP	—	2	2	2	2	2	2	2	2
COP ratio	% (relative to 410A)	96.7	96.9	97.1	97.3	95.1	95.3	95.7	95.9
Refrigerating capacity ratio	% (relative to 410A)	95.4	95.2	94.9	94.6	96.3	96.1	95.7	95.4
Condensation glide	° C.	1.86	1.83	1.80	1.77	2.14	2.14	2.13	2.12
Discharge pressure	% (relative to 410A)	101.2	100.6	100.0	99.5	104.5	104.0	103.0	102.5
RCL	g/m ³	42.7	42.0	41.3	40.6	50.7	49.7	47.7	46.8

TABLE 19

Item	Unit	Example 106	Example 107	Example 108	Example 109	Example 110	Example 111	Example 112	Example 113
HFO-1132(E)	mass %	46.0	48.0	52.0	54.0	56.0	58.0	34.0	36.0
HFO-1123	mass %	34.0	32.0	28.0	26.0	24.0	22.0	44.0	42.0
R1234yf	mass %	20.0	20.0	20.0	20.0	20.0	20.0	22.0	22.0
GWP	—	2	2	2	2	2	2	2	2
COP ratio	% (relative to 410A)	96.1	96.3	96.7	96.9	97.2	97.4	95.1	95.3
Refrigerating capacity ratio	% (relative to 410A)	95.2	95.0	94.5	94.2	94.0	93.7	95.3	95.1
Condensation glide	° C.	2.11	2.09	2.05	2.02	1.99	1.95	2.37	2.36

TABLE 19-continued

Item	Unit	Exam- ple 106	Exam- ple 107	Exam- ple 108	Exam- ple 109	Exam- ple 110	Exam- ple 111	Exam- ple 112	Exam- ple 113
Discharge pressure	% (relative to 410A)	101.9	101.4	100.3	99.7	99.2	98.6	103.4	103.0
RCL	g/m ³	45.9	45.0	43.4	42.7	41.9	41.2	51.7	50.6

TABLE 20

Item	Unit	Exam- ple 114	Exam- ple 115	Exam- ple 116	Exam- ple 117	Exam- ple 118	Exam- ple 119	Exam- ple 120	Exam- ple 121
HFO-1132(E)	mass %	38.0	40.0	42.0	44.0	46.0	48.0	50.0	52.0
HFO-1123	mass %	40.0	38.0	36.0	34.0	32.0	30.0	28.0	26.0
R1234yf	mass %	22.0	22.0	22.0	22.0	22.0	22.0	22.0	22.0
GWP	—	2	2	2	2	2	2	2	2
COP ratio	% (relative to 410A)	95.5	95.7	95.9	96.1	96.4	96.6	96.8	97.0
Refrigerating capacity ratio	% (relative to 410A)	94.9	94.7	94.5	94.3	94.0	93.8	93.6	93.3
Condensation glide	° C.	2.36	2.35	2.33	2.32	2.30	2.27	2.25	2.21
Discharge pressure	% (relative to 410A)	102.5	102.0	101.5	101.0	100.4	99.9	99.4	98.8
RCL	g/m ³	49.6	48.6	47.6	46.7	45.8	45.0	44.1	43.4

TABLE 21

Item	Unit	Exam- ple 122	Exam- ple 123	Exam- ple 124	Exam- ple 125	Exam- ple 126	Exam- ple 127	Exam- ple 128	Exam- ple 129
HFO-1132(E)	mass %	54.0	56.0	58.0	60.0	32.0	34.0	36.0	38.0
HFO-1123	mass %	24.0	22.0	20.0	18.0	44.0	42.0	40.0	38.0
R1234yf	mass %	22.0	22.0	22.0	22.0	24.0	24.0	24.0	24.0
GWP	—	2	2	2	2	2	2	2	2
COP ratio	% (relative to 410A)	97.2	97.4	97.6	97.9	95.2	95.4	95.6	95.8
Refrigerating capacity ratio	% (relative to 410A)	93.0	92.8	92.5	92.2	94.3	94.1	93.9	93.7
Condensation glide	° C.	2.18	2.14	2.09	2.04	2.61	2.60	2.59	2.58
Discharge pressure	% (relative to 410A)	98.2	97.7	97.1	96.5	102.4	101.9	101.5	101.0
RCL	g/m ³	42.6	41.9	41.2	40.5	52.7	51.6	50.5	49.5

TABLE 22

Item	Unit	Exam- ple 130	Exam- ple 131	Exam- ple 132	Exam- ple 133	Exam- ple 134	Exam- ple 135	Exam- ple 136	Exam- ple 137
HFO-1132(E)	mass %	40.0	42.0	44.0	46.0	48.0	50.0	52.0	54.0
HFO-1123	mass %	36.0	34.0	32.0	30.0	28.0	26.0	24.0	22.0
R1234yf	mass %	24.0	24.0	24.0	24.0	24.0	24.0	24.0	24.0
GWP	—	2	2	2	2	2	2	2	2
COP ratio	% (relative to 410A)	96.0	96.2	96.4	96.6	96.8	97.0	97.2	97.5
Refrigerating capacity ratio	% (relative to 410A)	93.5	93.3	93.1	92.8	92.6	92.4	92.1	91.8
Condensation glide	° C.	2.56	2.54	2.51	2.49	2.45	2.42	2.38	2.33
Discharge pressure	% (relative to 410A)	100.5	100.0	99.5	98.9	98.4	97.9	97.3	96.8
RCL	g/m ³	48.5	47.5	46.6	45.7	44.9	44.1	43.3	42.5

TABLE 23

Item	Unit	Example 138	Example 139	Example 140	Example 141	Example 142	Example 143	Example 144	Example 145
HFO-1132(E)	mass %	56.0	58.0	60.0	30.0	32.0	34.0	36.0	38.0
HFO-1123	mass %	20.0	18.0	16.0	44.0	42.0	40.0	38.0	36.0
R1234yf	mass %	24.0	24.0	24.0	26.0	26.0	26.0	26.0	26.0
GWP	—	2	2	2	2	2	2	2	2
COP ratio	% (relative to 410A)	97.7	97.9	98.1	95.3	95.5	95.7	95.9	96.1
Refrigerating capacity ratio	% (relative to 410A)	91.6	91.3	91.0	93.2	93.1	92.9	92.7	92.5
Condensation glide	° C.	2.28	2.22	2.16	2.86	2.85	2.83	2.81	2.79
Discharge pressure	% (relative to 410A)	96.2	95.6	95.1	101.3	100.8	100.4	99.9	99.4
RCL	g/m ³	41.8	41.1	40.4	53.7	52.6	51.5	50.4	49.4

TABLE 24

Item	Unit	Example 146	Example 147	Example 148	Example 149	Example 150	Example 151	Example 152	Example 153
HFO-1132(E)	mass %	40.0	42.0	44.0	46.0	48.0	50.0	52.0	54.0
HFO-1123	mass %	34.0	32.0	30.0	28.0	26.0	24.0	22.0	20.0
R1234yf	mass %	26.0	26.0	26.0	26.0	26.0	26.0	26.0	26.0
GWP	—	2	2	2	2	2	2	2	2
COP ratio	% (relative to 410A)	96.3	96.5	96.7	96.9	97.1	97.3	97.5	97.7
Refrigerating capacity ratio	% (relative to 410A)	92.3	92.1	91.9	91.6	91.4	91.2	90.9	90.6
Condensation glide	° C.	2.77	2.74	2.71	2.67	2.63	2.59	2.53	2.48
Discharge pressure	% (relative to 410A)	99.0	98.5	97.9	97.4	96.9	96.4	95.8	95.3
RCL	g/m ³	48.4	47.4	46.5	45.7	44.8	44.0	43.2	42.5

TABLE 25

Item	Unit	Example 154	Example 155	Example 156	Example 157	Example 158	Example 159	Example 160	Example 161
HFO-1132(E)	mass %	56.0	58.0	60.0	30.0	32.0	34.0	36.0	38.0
HFO-1123	mass %	18.0	16.0	14.0	42.0	40.0	38.0	36.0	34.0
R1234yf	mass %	26.0	26.0	26.0	28.0	28.0	28.0	28.0	28.0
GWP	—	2	2	2	2	2	2	2	2
COP ratio	% (relative to 410A)	97.9	98.2	98.4	95.6	95.8	96.0	96.2	96.3
Refrigerating capacity ratio	% (relative to 410A)	90.3	90.1	89.8	92.1	91.9	91.7	91.5	91.3
Condensation glide	° C.	2.42	2.35	2.27	3.10	3.09	3.06	3.04	3.01
Discharge pressure	% (relative to 410A)	94.7	94.1	93.6	99.7	99.3	98.8	98.4	97.9
RCL	g/m ³	41.7	41.0	40.3	53.6	52.5	51.4	50.3	49.3

TABLE 26

Item	Unit	Example 162	Example 163	Example 164	Example 165	Example 166	Example 167	Example 168	Example 169
HFO-1132(E)	mass %	40.0	42.0	44.0	46.0	48.0	50.0	52.0	54.0
HFO-1123	mass %	32.0	30.0	28.0	26.0	24.0	22.0	20.0	18.0
R1234yf	mass %	28.0	28.0	28.0	28.0	28.0	28.0	28.0	28.0
GWP	—	2	2	2	2	2	2	2	2
COP ratio	% (relative to 410A)	96.5	96.7	96.9	97.2	97.4	97.6	97.8	98.0
Refrigerating capacity ratio	% (relative to 410A)	91.1	90.9	90.7	90.4	90.2	89.9	89.7	89.4
Condensation glide	° C.	2.98	2.94	2.90	2.85	2.80	2.75	2.68	2.62

TABLE 26-continued

Item	Unit	Exam- ple 162	Exam- ple 163	Exam- ple 164	Exam- ple 165	Exam- ple 166	Exam- ple 167	Exam- ple 168	Exam- ple 169
Discharge pressure	% (relative to 410A)	97.4	96.9	96.4	95.9	95.4	94.9	94.3	93.8
RCL	g/m ³	48.3	47.4	46.4	45.6	44.7	43.9	43.1	42.4

TABLE 27

Item	Unit	Exam- ple 170	Exam- ple 171	Exam- ple 172	Exam- ple 173	Exam- ple 174	Exam- ple 175	Exam- ple 176	Exam- ple 177
HFO-1132(E)	mass %	56.0	58.0	60.0	32.0	34.0	36.0	38.0	42.0
HFO-1123	mass %	16.0	14.0	12.0	38.0	36.0	34.0	32.0	28.0
R1234yf	mass %	28.0	28.0	28.0	30.0	30.0	30.0	30.0	30.0
GWP	—	2	2	2	2	2	2	2	2
COP ratio	% (relative to 410A)	98.2	98.4	98.6	96.1	96.2	96.4	96.6	97.0
Refrigerating capacity ratio	% (relative to 410A)	89.1	88.8	88.5	90.7	90.5	90.3	90.1	89.7
Condensation glide	° C.	2.54	2.46	2.38	3.32	3.30	3.26	3.22	3.14
Discharge pressure	% (relative to 410A)	93.2	92.6	92.1	97.7	97.3	96.8	96.4	95.4
RCL	g/m ³	41.7	41.0	40.3	52.4	51.3	50.2	49.2	47.3

TABLE 28

Item	Unit	Exam- ple 178	Exam- ple 179	Exam- ple 180	Exam- ple 181	Exam- ple 182	Exam- ple 183	Exam- ple 184	Exam- ple 185
HFO-1132(E)	mass %	44.0	46.0	48.0	50.0	52.0	54.0	56.0	58.0
HFO-1123	mass %	26.0	24.0	22.0	20.0	18.0	16.0	14.0	12.0
R1234yf	mass %	30.0	30.0	30.0	30.0	30.0	30.0	30.0	30.0
GWP	—	2	2	2	2	2	2	2	2
COP ratio	% (relative to 410A)	97.2	97.4	97.6	97.8	98.0	98.3	98.5	98.7
Refrigerating capacity ratio	% (relative to 410A)	89.4	89.2	89.0	88.7	88.4	88.2	87.9	87.6
Condensation glide	° C.	3.08	3.03	2.97	2.90	2.83	2.75	2.66	2.57
Discharge pressure	% (relative to 410A)	94.9	94.4	93.9	93.3	92.8	92.3	91.7	91.1
RCL	g/m ³	46.4	45.5	44.7	43.9	43.1	42.3	41.6	40.9

TABLE 29

Item	Unit	Exam- ple 186	Exam- ple 187	Exam- ple 188	Exam- ple 189	Exam- ple 190	Exam- ple 191	Exam- ple 192	Exam- ple 193
HFO-1132(E)	mass %	30.0	32.0	34.0	36.0	38.0	40.0	42.0	44.0
HFO-1123	mass %	38.0	36.0	34.0	32.0	30.0	28.0	26.0	24.0
R1234yf	mass %	32.0	32.0	32.0	32.0	32.0	32.0	32.0	32.0
GWP	—	2	2	2	2	2	2	2	2
COP ratio	% (relative to 410A)	96.2	96.3	96.5	96.7	96.9	97.1	97.3	97.5
Refrigerating capacity ratio	% (relative to 410A)	89.6	89.5	89.3	89.1	88.9	88.7	88.4	88.2
Condensation glide	° C.	3.60	3.56	3.52	3.48	3.43	3.38	3.33	3.26
Discharge pressure	% (relative to 410A)	96.6	96.2	95.7	95.3	94.8	94.3	93.9	93.4
RCL	g/m ³	53.4	52.3	51.2	50.1	49.1	48.1	47.2	46.3

TABLE 30

Item	Unit	Example 194	Example 195	Example 196	Example 197	Example 198	Example 199	Example 200	Example 201
HFO-1132(E)	mass %	46.0	48.0	50.0	52.0	54.0	56.0	58.0	60.0
HFO-1123	mass %	22.0	20.0	18.0	16.0	14.0	12.0	10.0	8.0
R1234yf	mass %	32.0	32.0	32.0	32.0	32.0	32.0	32.0	32.0
GWP	—	2	2	2	2	2	2	2	2
COP ratio	% (relative to 410A)	97.7	97.9	98.1	98.3	98.5	98.7	98.9	99.2
Refrigerating capacity ratio	% (relative to 410A)	88.0	87.7	87.5	87.2	86.9	86.6	86.3	86.0
Condensation glide	° C.	3.20	3.12	3.04	2.96	2.87	2.77	2.66	2.55
Discharge pressure	% (relative to 410A)	92.8	92.3	91.8	91.3	90.7	90.2	89.6	89.1
RCL	g/m ³	45.4	44.6	43.8	43.0	42.3	41.5	40.8	40.2

TABLE 31

Item	Unit	Example 202	Example 203	Example 204	Example 205	Example 206	Example 207	Example 208	Example 209
HFO-1132(E)	mass %	30.0	32.0	34.0	36.0	38.0	40.0	42.0	44.0
HFO-1123	mass %	36.0	34.0	32.0	30.0	28.0	26.0	24.0	22.0
R1234yf	mass %	34.0	34.0	34.0	34.0	34.0	34.0	34.0	34.0
GWP	—	2	2	2	2	2	2	2	2
COP ratio	% (relative to 410A)	96.5	96.6	96.8	97.0	97.2	97.4	97.6	97.8
Refrigerating capacity ratio	% (relative to 410A)	88.4	88.2	88.0	87.8	87.6	87.4	87.2	87.0
Condensation glide	° C.	3.84	3.80	3.75	3.70	3.64	3.58	3.51	3.43
Discharge pressure	% (relative to 410A)	95.0	94.6	94.2	93.7	93.3	92.8	92.3	91.8
RCL	g/m ³	53.3	52.2	51.1	50.0	49.0	48.0	47.1	46.2

TABLE 32

Item	Unit	Example 210	Example 211	Example 212	Example 213	Example 214	Example 215	Example 216	Example 217
HFO-1132(E)	mass %	46.0	48.0	50.0	52.0	54.0	30.0	32.0	34.0
HFO-1123	mass %	20.0	18.0	16.0	14.0	12.0	34.0	32.0	30.0
R1234yf	mass %	34.0	34.0	34.0	34.0	34.0	36.0	36.0	36.0
GWP	—	2	2	2	2	2	2	2	2
COP ratio	% (relative to 410A)	98.0	98.2	98.4	98.6	98.8	96.8	96.9	97.1
Refrigerating capacity ratio	% (relative to 410A)	86.7	86.5	86.2	85.9	85.6	87.2	87.0	86.8
Condensation glide	° C.	3.36	3.27	3.18	3.08	2.97	4.08	4.03	3.97
Discharge pressure	% (relative to 410A)	91.3	90.8	90.3	89.7	89.2	93.4	93.0	92.6
RCL	g/m ³	45.3	44.5	43.7	42.9	42.2	53.2	52.1	51.0

TABLE 33

Item	Unit	Example 218	Example 219	Example 220	Example 221	Example 222	Example 223	Example 224	Example 225
HFO-1132(E)	mass %	36.0	38.0	40.0	42.0	44.0	46.0	30.0	32.0
HFO-1123	mass %	28.0	26.0	24.0	22.0	20.0	18.0	32.0	30.0
R1234yf	mass %	36.0	36.0	36.0	36.0	36.0	36.0	38.0	38.0
GWP	—	2	2	2	2	2	2	2	2
COP ratio	% (relative to 410A)	97.3	97.5	97.7	97.9	98.1	98.3	97.1	97.2
Refrigerating capacity ratio	% (relative to 410A)	86.6	86.4	86.2	85.9	85.7	85.5	85.9	85.7
Condensation glide	° C.	3.91	3.84	3.76	3.68	3.60	3.50	4.32	4.25

TABLE 33-continued

Item	Unit	Exam- ple 218	Exam- ple 219	Exam- ple 220	Exam- ple 221	Exam- ple 222	Exam- ple 223	Exam- ple 224	Exam- ple 225
Discharge pressure	% (relative to 410A)	92.1	91.7	91.2	90.7	90.3	89.8	91.9	91.4
RCL	g/m ³	49.9	48.9	47.9	47.0	46.1	45.3	53.1	52.0

TABLE 34

Item	Unit	Example 226	Example 227
HFO-1132(E)	mass %	34.0	36.0
HFO-1123	mass %	28.0	26.0
R1234yf	mass %	38.0	38.0
GWP	—	2	2
COP ratio	% (relative to 410A)	97.4	97.6
Refrigerating capacity ratio	% (relative to 410A)	85.6	85.3
Condensation glide	° C.	4.18	4.11
Discharge pressure	% (relative to 410A)	91.0	90.6
RCL	g/m ³	50.9	49.8

[0372] These results indicate that under the condition that the mass % of HFO-1132(E), HFO-1123, and R1234yf based on their sum is respectively represented by x, y, and z, when coordinates (x,y,z) in a ternary composition diagram in which the sum of HFO-1132(E), HFO-1123, and R1234yf is 100 mass % are within the range of a figure surrounded by line segments AA', A'B, BD, DC', C'C, CO, and OA that connect the following 7 points:

- point A (68.6, 0.0, 31.4),
- point A'(30.6, 30.0, 39.4),
- point B (0.0, 58.7, 41.3),
- point D (0.0, 80.4, 19.6),
- point C' (19.5, 70.5, 10.0),
- point C (32.9, 67.1, 0.0), and
- point O (100.0, 0.0, 0.0),

or on the above line segments (excluding the points on the line segment CO);

the line segment AA' is represented by coordinates (x, 0.0016x²-0.9473x+57.497, -0.0016x²-0.0527x+42.503), the line segment A'B is represented by coordinates (x, 0.0029x²-1.0268x+58.7, -0.0029x²+0.0268x+41.3), the line segment DC' is represented by coordinates (x, 0.0082x²-0.6671x+80.4, -0.0082x²-0.3329x+19.6), the line segment C'C is represented by coordinates (x, 0.0067x²-0.6034x+79.729, -0.0067x²-0.3966x+20.271), and

the line segments BD, CO, and OA are straight lines, the refrigerant has a refrigerating capacity ratio of 85% or more relative to that of R410A, and a COP of 92.5% or more relative to that of R410A.

[0373] The point on the line segment AA' was determined by obtaining an approximate curve connecting point A, Example 1, and point A' by the least square method.

[0374] The point on the line segment A'B was determined by obtaining an approximate curve connecting point A', Example 3, and point B by the least square method.

[0375] The point on the line segment DC' was determined by obtaining an approximate curve connecting point D, Example 6, and point C' by the least square method.

[0376] The point on the line segment C'C was determined by obtaining an approximate curve connecting point C', Example 4, and point C by the least square method.

[0377] Likewise, the results indicate that when coordinates (x,y,z) are within the range of a figure surrounded by line segments AA', A'B, BF, FT, TE, EO, and OA that connect the following 7 points:

- point A (68.6, 0.0, 31.4),
- point A' (30.6, 30.0, 39.4),
- point B (0.0, 58.7, 41.3),
- point F (0.0, 61.8, 38.2),
- point T (35.8, 44.9, 19.3),
- point E (58.0, 42.0, 0.0) and
- point O (100.0, 0.0, 0.0),

or on the above line segments (excluding the points on the line EO);

the line segment AA' is represented by coordinates (x, 0.0016x²-0.9473x+57.497, -0.0016x²-0.0527x+42.503), the line segment A'B is represented by coordinates (x, 0.0029x²-1.0268x+58.7, -0.0029x²+0.0268x+41.3), the line segment FT is represented by coordinates (x, 0.0078x²-0.7501x+61.8, -0.0078x²-0.2499x+38.2), and the line segment TE is represented by coordinates (x, 0.0067x²-0.7607x+63.525, -0.0067x²-0.2393x+36.475), and

the line segments BF, FO, and OA are straight lines, the refrigerant has a refrigerating capacity ratio of 85% or more relative to that of R410A, and a COP of 95% or more relative to that of R410A.

[0378] The point on the line segment FT was determined by obtaining an approximate curve connecting three points, i.e., points T, E', and F, by the least square method.

[0379] The point on the line segment TE was determined by obtaining an approximate curve connecting three points, i.e., points E, R, and T, by the least square method.

[0380] The results in Tables 1 to 34 clearly indicate that in a ternary composition diagram of the mixed refrigerant of HFO-1132(E), HFO-1123, and R1234yf in which the sum of these components is 100 mass %, a line segment connecting a point (0.0, 100.0, 0.0) and a point (0.0, 0.0, 100.0) is the base, the point (0.0, 100.0, 0.0) is on the left side, and the point (0.0, 0.0, 100.0) is on the right side, when coordinates (x,y,z) are on or below the line segment LM connecting point L (63.1, 31.9, 5.0) and point M (60.3, 6.2, 33.5), the refrigerant has an RCL of 40 g/m³ or more.

[0381] The results in Tables 1 to 34 clearly indicate that in a ternary composition diagram of the mixed refrigerant of HFO-1132(E), HFO-1123 and R1234yf in which their sum is 100 mass %, a line segment connecting a point (0.0, 100.0, 0.0) and a point (0.0, 0.0, 100.0) is the base, the point (0.0, 100.0, 0.0) is on the left side, and the point (0.0, 0.0, 100.0) is on the right side, when coordinates (x,y,z) are on the line segment QR connecting point Q (62.8, 29.6, 7.6) and point R (49.8, 42.3, 7.9) or on the left side of the line segment, the refrigerant has a temperature glide of 1° C. or less.

[0382] The results in Tables 1 to 34 clearly indicate that in a ternary composition diagram of the mixed refrigerant of HFO-1132(E), HFO-1123, and R1234yf in which their sum is 100 mass %, a line segment connecting a point (0.0, 100.0, 0.0) and a point (0.0, 0.0, 100.0) is the base, the point (0.0, 100.0, 0.0) is on the left side, and the point (0.0, 0.0, 100.0) is on the right side, when coordinates (x,y,z) are on the line segment ST connecting point S (62.6, 28.3, 9.1) and point T (35.8, 44.9, 19.3) or on the right side of the line segment, the refrigerant has a discharge pressure of 105% or less relative to that of 410A.

[0383] In these compositions, R1234yf contributes to reducing flammability, and suppressing deterioration of polymerization etc. Therefore, the composition preferably contains R1234yf.

[0386] Each WCF concentration was obtained by using the WCF concentration as the initial concentration and performing a leak simulation using NIST Standard Reference Database REFLEAK Version 4.0.

[0387] Tables 35 and 36 show the results.

TABLE 35

	Item	Unit	G	H	I
WCF	HFO-1132(E)	mass %	72.0	72.0	72.0
	HFO-1123	mass %	28.0	9.6	0.0
	R1234yf	mass %	0.0	18.4	28.0
Burning velocity (WCF)	cm/s		10	10	10

TABLE 36

	Item	Unit	J	P	L	N	N'	K
WCF	HFO-1132(E)	mass %	47.1	55.8	63.1	68.6	65.0	61.3
	HFO-1123	mass %	52.9	42.0	31.9	16.3	7.7	5.4
	R1234yf	mass %	0.0	2.2	5.0	15.1	27.3	33.3
	Leak condition that results in WCF		Storage/Shipping -40° C., 92% release, liquid phase side	Storage/Shipping -40° C., 90% release, liquid phase side	Storage/Shipping -40° C., 90% release, gas phase side	Storage/Shipping -40° C., 66% release, gas phase side	Storage/Shipping -40° C., 12% release, gas phase side	Storage/Shipping, -40° C., 0% release, gas phase side
WCF	HFO-1132(E)	mass %	72.0	72.0	72.0	72.0	72.0	72.0
	HFO-1123	mass %	28.0	17.8	17.4	13.6	12.3	9.8
	R1234yf	mass %	0.0	10.2	10.6	14.4	15.7	18.2
	Burning velocity (WCF)	cm/s	8 or less	8 or less	8 or less	9	9	8 or less
	Burning velocity (WCF)	cm/s	10	10	10	10	10	10

[0384] Further, the burning velocity of these mixed refrigerants whose mixed formulations were adjusted to WCF concentrations was measured according to the ANSI/ASHRAE Standard 34-2013. Compositions having a burning velocity of 10 cm/s or less were determined to be classified as “Class 2L (lower flammability).”

[0385] A burning velocity test was performed using the apparatus shown in FIG. 1 in the following manner. In FIG. 1, reference numeral **901** refers to a sample cell, **902** refers to a high-speed camera, **903** refers to a xenon lamp, **904** refers to a collimating lens, **905** refers to a collimating lens, and **906** refers to a ring filter. First, the mixed refrigerants used had a purity of 99.5% or more, and were degassed by repeating a cycle of freezing, pumping, and thawing until no traces of air were observed on the vacuum gauge. The burning velocity was measured by the closed method. The initial temperature was ambient temperature. Ignition was performed by generating an electric spark between the electrodes in the center of a sample cell. The duration of the discharge was 1.0 to 9.9 ms, and the ignition energy was typically about 0.1 to 1.0 J. The spread of the flame was visualized using schlieren photographs. A cylindrical container (inner diameter: 155 mm, length: 198 mm) equipped with two light transmission acrylic windows was used as the sample cell, and a xenon lamp was used as the light source. Schlieren images of the flame were recorded by a high-speed digital video camera at a frame rate of 600 fps and stored on a PC.

[0388] The results in Table 35 clearly indicate that when a mixed refrigerant of HFO-1132(E), HFO-1123, and R1234yf contains HFO-1132(E) in a proportion of 72.0 mass % or less based on their sum, the refrigerant can be determined to have a WCF lower flammability.

[0389] The results in Tables 36 clearly indicate that in a ternary composition diagram of a mixed refrigerant of HFO-1132(E), HFO-1123, and R1234yf in which their sum is 100 mass %, and a line segment connecting a point (0.0, 100.0, 0.0) and a point (0.0, 0.0, 100.0) is the base, when coordinates (x,y,z) are on or below the line segments JP, PN, and NK connecting the following 6 points:

point J (47.1, 52.9, 0.0),
 point P (55.8, 42.0, 2.2),
 point L (63.1, 31.9, 5.0)
 point N (68.6, 16.3, 15.1)
 point N' (65.0, 7.7, 27.3) and
 point K (61.3, 5.4, 33.3),

the refrigerant can be determined to have a WCF lower flammability, and a WCF lower flammability.

In the diagram, the line segment PN is represented by coordinates (x, $-0.1135x^2+12.112x-280.43$, $0.1135x^2-13.112x+380.43$),

and the line segment NK is represented by coordinates (x, $0.2421x^2-29.955x+931.91$, $-0.2421x^2+28.955x-831.91$).

[0390] The point on the line segment PN was determined by obtaining an approximate curve connecting three points, i.e., points P, L, and N, by the least square method.

[0391] The point on the line segment NK was determined by obtaining an approximate curve connecting three points, i.e., points N, N', and K, by the least square method.

(5-2) Refrigerant B

[0392] The refrigerant B according to the present disclosure is

[0393] a mixed refrigerant comprising trans-1,2-difluoroethylene (HFO-1132(E)) and trifluoroethylene (HFO-1123) in a total amount of 99.5 mass % or more based on the entire refrigerant, and the refrigerant comprising 62.0 mass % to 72.0 mass % or 45.1 mass % to 47.1 mass % of HFO-1132 (E) based on the entire refrigerant, or

[0394] a mixed refrigerant comprising HFO-1132(E) and HFO-1123 in a total amount of 99.5 mass % or more based on the entire refrigerant, and the refrigerant comprising 45.1 mass % to 47.1 mass % of HFO-1132(E) based on the entire refrigerant.

[0395] The refrigerant B according to the present disclosure has various properties that are desirable as an R410A-alternative refrigerant, i.e., (1) a coefficient of performance equivalent to that of R410A, (2) a refrigerating capacity equivalent to that of R410A, (3) a sufficiently low GWP, and (4) a lower flammability (Class 2L) according to the ASHRAE standard.

[0396] When the refrigerant B according to the present disclosure is a mixed refrigerant comprising 72.0 mass % or less of HFO-1132(E), it has WCF lower flammability. When the refrigerant B according to the present disclosure is a composition comprising 47.1% or less of HFO-1132(E), it has WCF lower flammability and WCF lower flammability, and is determined to be "Class 2L," which is a lower flammable refrigerant according to the ASHRAE standard, and which is further easier to handle.

[0397] When the refrigerant B according to the present disclosure comprises 62.0 mass % or more of HFO-1132(E), it becomes superior with a coefficient of performance of 95% or more relative to that of R410A, the polymerization reaction of HFO-1132(E) and/or HFO-1123 is further suppressed, and the stability is further improved. When the refrigerant B according to the present disclosure comprises 45.1 mass % or more of HFO-1132(E), it becomes superior with a coefficient of performance of 93% or more relative to that of R410A, the polymerization reaction of HFO-1132(E) and/or HFO-1123 is further suppressed, and the stability is further improved.

[0398] The refrigerant B according to the present disclosure may further comprise other additional refrigerants in addition to HFO-1132(E) and HFO-1123, as long as the above properties and effects are not impaired. In this respect, the refrigerant according to the present disclosure preferably comprises HFO-1132(E) and HFO-1123 in a total amount of 99.75 mass % or more, and more preferably 99.9 mass % or more, based on the entire refrigerant.

[0399] Such additional refrigerants are not limited, and can be selected from a wide range of refrigerants. The mixed refrigerant may comprise a single additional refrigerant, or two or more additional refrigerants.

(Examples of Refrigerant B)

[0400] The present disclosure is described in more detail below with reference to Examples of refrigerant B. However, the refrigerant B is not limited to the Examples.

[0401] Mixed refrigerants were prepared by mixing HFO-1132(E) and HFO-1123 at mass % based on their sum shown in Tables 37 and 38.

[0402] The GWP of compositions each comprising a mixture of R410A (R32=50%/R125=50%) was evaluated based on the values stated in the Intergovernmental Panel on Climate Change (IPCC), fourth report. The GWP of HFO-1132(E), which was not stated therein, was assumed to be 1 from HFO-1132a (GWP=1 or less) and HFO-1123 (GWP=0.3, described in Patent Literature 1). The refrigerating capacity of compositions each comprising R410A and a mixture of HFO-1132(E) and HFO-1123 was determined by performing theoretical refrigeration cycle calculations for the mixed refrigerants using the National Institute of Science and Technology (NIST) and Reference Fluid Thermodynamic and Transport Properties Database (Refprop 9.0) under the following conditions.

Evaporating temperature: 5° C.

Condensation temperature: 45° C.

Superheating temperature: 5 K

Subcooling temperature: 5 K

Compressor efficiency: 70%

[0403] The composition of each mixture was defined as WCF. A leak simulation was performed using NIST Standard Reference Data Base Refleak Version 4.0 under the conditions of Equipment, Storage, Shipping, Leak, and Recharge according to the ASHRAE Standard 34-2013. The most flammable fraction was defined as WCF.

[0404] Tables 1 and 2 show GWP, COP, and refrigerating capacity, which were calculated based on these results. The COP and refrigerating capacity are ratios relative to R410A.

[0405] The coefficient of performance (COP) was determined by the following formula.

$$\text{COP} = \frac{\text{refrigerating capacity or heating capacity}}{\text{power consumption}}$$

[0406] For the flammability, the burning velocity was measured according to the ANSI/ASHRAE Standard 34-2013. Both WCF and WCF having a burning velocity of 10 cm/s or less were determined to be "Class 2L (lower flammability)."

[0407] A burning velocity test was performed using the apparatus shown in FIG. 1 in the following manner. First, the mixed refrigerants used had a purity of 99.5% or more, and were degassed by repeating a cycle of freezing, pumping, and thawing until no traces of air were observed on the vacuum gauge. The burning velocity was measured by the closed method. The initial temperature was ambient temperature. Ignition was performed by generating an electric spark between the electrodes in the center of a sample cell. The duration of the discharge was 1.0 to 9.9 ms, and the ignition energy was typically about 0.1 to 1.0 J. The spread of the flame was visualized using schlieren photographs. A cylindrical container (inner diameter: 155 mm, length: 198 mm) equipped with two light transmission acrylic windows was used as the sample cell, and a xenon lamp was used as the light source. Schlieren images of the flame were recorded by a high-speed digital video camera at a frame rate of 600 fps and stored on a PC.

TABLE 37

Item	Unit	Comparative Example 1 R410A	Comparative Example 2 HFO-1132E	Comparative Example 3	Example 1	Example 2	Example 3	Example 4	Example 5	Comparative Example 4
HFO-1132E (WCF)	mass %	—	100	80	72	70	68	65	62	60
HFO-1123 (WCF)	mass %		0	20	28	30	32	35	38	40
GWP	—	2088	1	1	1	1	1	1	1	1
COP ratio	% (relative to R410A)	100	99.7	97.5	96.6	96.3	96.1	95.8	95.4	95.2
Refrigerating capacity ratio	% (relative to R410A)	100	98.3	101.9	103.1	103.4	103.8	104.1	104.5	104.8
Discharge pressure	Mpa	2.73	2.71	2.89	2.96	2.98	3.00	3.02	3.04	3.06
Burning velocity (WCF)	cm/sec	Non-flammable	20	13	10	9	9	8	8 or less	8 or less

TABLE 38

Item	Unit	Comparative Example 5	Comparative Example 6	Example 7	Example 8	Example 9
HFO-1132E (WCF)	mass %	50	48	47.1	46.1	45.1
HFO-1123 (WCF)	mass %	50	52	52.9	53.9	54.9
GWP	—	1	1	1	1	1
COP ratio	% (relative to R410A)	94.1	93.9	93.8	93.7	93.6
Refrigerating capacity ratio	% (relative to R410A)	105.9	106.1	106.2	106.3	106.4
Discharge pressure	Mpa	3.14	3.16	3.16	3.17	3.18
Leakage test conditions (WCFF)		Storage/Shipping -40° C., 92% release, liquid phase side	Storage/Shipping -40° C., 92% release, liquid phase side	Storage/Shipping -40° C., 92% release, liquid phase side	Storage/Shipping -40° C., 92% release, liquid phase side	Storage/Shipping -40° C., 92% release, liquid phase side
HFO-1132E (WCFF)	mass %	74	73	72	71	70
HFO-1123 (WCFF)	mass %	26	27	28	29	30
Burning velocity (WCF)	cm/sec	8 or less	8 or less	8 or less	8 or less	8 or less
Burning velocity (WCFF)	cm/sec	11	10.5	10.0	9.5	9.5
ASHRAE flammability classification		2	2	2L	2L	2L

Item	Unit	Comparative Example 7	Comparative Example 8	Comparative Example 9	Comparative Example 10 HFO-1123
HFO-1132E (WCF)	mass %	43	40	25	0
HFO-1123 (WCF)	mass %	57	60	75	100
GWP	—	1	1	1	1
COP ratio	% (relative to R410A)	93.4	93.1	91.9	90.6
Refrigerating capacity ratio	% (relative to R410A)	106.6	106.9	107.9	108.0
Discharge pressure	Mpa	3.20	3.21	3.31	3.39
Leakage test conditions (WCFF)		Storage/Shipping -40° C., 92% release, liquid phase side	Storage/Shipping -40° C., 92% release, liquid phase side	Storage/Shipping -40° C., 90% release, liquid phase side	—

TABLE 38-continued

HFO-1132E (WCFF)	mass %	67	63	38	—
HFO-1123 (WCFF)	mass %	33	37	62	
Burning velocity (WCF)	cm/sec	8 or less	8 or less	8 or less	5
Burning velocity (WCFF)	cm/sec	8.5	8 or less	8 or less	
ASHRAE flammability classification		2L	2L	2L	2L

[0408] The compositions each comprising 62.0 mass % to 72.0 mass % of HFO-1132(E) based on the entire composition are stable while having a low GWP (GWP=1), and they ensure WCF lower flammability. Further, surprisingly, they can ensure performance equivalent to that of R410A. Moreover, compositions each comprising 45.1 mass % to 47.1 mass % of HFO-1132(E) based on the entire composition are stable while having a low GWP (GWP=1), and they ensure WCFF lower flammability. Further, surprisingly, they can ensure performance equivalent to that of R410A.

(5-3) Refrigerant C

[0409] The refrigerant C according to the present disclosure is a composition comprising trans-1,2-difluoroethylene (HFO-1132(E)), trifluoroethylene (HFO-1123), 2,3,3,3-tetrafluoro-1-propene (R1234yf), and difluoromethane (R32), and satisfies the following requirements. The refrigerant C according to the present disclosure has various properties that are desirable as an alternative refrigerant for R410A; i.e. it has a coefficient of performance and a refrigerating capacity that are equivalent to those of R410A, and a sufficiently low GWP.

Requirements

[0410] Preferable refrigerant C is as follows:

[0411] When the mass % of HFO-1132(E), HFO-1123, R1234yf, and R32 based on their sum is respectively represented by x, y, z, and a, if $0 < a \leq 11.1$, coordinates (x,y,z) in a ternary composition diagram in which the sum of HFO-1132(E), HFO-1123, and R1234yf is (100-a) mass % are within the range of a figure surrounded by straight lines GI, IA, AB, BD', D'C, and CG that connect the following 6 points:

point G ($0.026a^2 - 1.7478a + 72.0$, $-0.026a^2 + 0.7478a + 28.0$, 0.0),

point I ($0.026a^2 - 1.7478a + 72.0$, 0.0, $-0.026a^2 + 0.7478a + 28.0$),

point A ($0.0134a^2 - 1.9681a + 68.6$, 0.0, $-0.0134a^2 + 0.9681a + 31.4$),

point B (0.0, $0.0144a^2 - 1.6377a + 58.7$, $-0.0144a^2 + 0.6377a + 41.3$),

point D' (0.0, $0.0224a^2 + 0.968a + 75.4$, $-0.0224a^2 - 1.968a + 24.6$), and

point C ($-0.2304a^2 - 0.4062a + 32.9$, $0.2304a^2 - 0.5938a + 67.1$, 0.0),

or on the straight lines GI, AB, and D'C (excluding point G, point I, point A, point B, point D', and point C);

[0412] if $11.1 < a \leq 18.2$, coordinates (x,y,z) in the ternary composition diagram are within the range of a figure sur-

rounded by straight lines GI, IA, AB, BW, and WG that connect the following 5 points:

point G ($0.02a^2 - 1.6013a + 71.105$, $-0.02a^2 + 0.6013a + 28.895$, 0.0),

point I ($0.02a^2 - 1.6013a + 71.105$, 0.0, $-0.02a^2 + 0.6013a + 28.895$),

point A ($0.0112a^2 - 1.9337a + 68.484$, 0.0, $-0.0112a^2 + 0.9337a + 31.516$),

point B (0.0, $0.0075a^2 - 1.5156a + 58.199$, $-0.0075a^2 + 0.5156a + 41.801$) and

point W (0.0, 100.0-a, 0.0),

or on the straight lines GI and AB (excluding point G, point I, point A, point B, and point W);

[0413] if $18.2 < a \leq 26.7$, coordinates (x,y,z) in the ternary composition diagram are within the range of a figure surrounded by straight lines GI, IA, AB, BW, and WG that connect the following 5 points:

point G ($0.0135a^2 - 1.4068a + 69.727$, $-0.0135a^2 + 0.4068a + 30.273$, 0.0),

point I ($0.0135a^2 - 1.4068a + 69.727$, 0.0, $-0.0135a^2 + 0.4068a + 30.273$),

point A ($0.0107a^2 - 1.9142a + 68.305$, 0.0, $-0.0107a^2 + 0.9142a + 31.695$),

point B (0.0, $0.009a^2 - 1.6045a + 59.318$, $-0.009a^2 + 0.6045a + 40.682$) and

point W (0.0, 100.0-a, 0.0),

or on the straight lines GI and AB (excluding point G, point I, point A, point B, and point W);

[0414] if $26.7 < a \leq 36.7$, coordinates (x,y,z) in the ternary composition diagram are within the range of a figure surrounded by straight lines GI, IA, AB, BW, and WG that connect the following 5 points:

point G ($0.0111a^2 - 1.3152a + 68.986$, $-0.0111a^2 + 0.3152a + 31.014$, 0.0),

point I ($0.0111a^2 - 1.3152a + 68.986$, 0.0, $-0.0111a^2 + 0.3152a + 31.014$),

point A ($0.0103a^2 - 1.9225a + 68.793$, 0.0, $-0.0103a^2 + 0.9225a + 31.207$),

point B (0.0, $0.0046a^2 - 1.41a + 57.286$, $-0.0046a^2 + 0.41a + 42.714$) and

point W (0.0, 100.0-a, 0.0),

or on the straight lines GI and AB (excluding point G, point I, point A, point B, and point W); and

[0415] if $36.7 < a \leq 46.7$, coordinates (x,y,z) in the ternary composition diagram are within the range of a figure surrounded by straight lines GI, IA, AB, BW, and WG that connect the following 5 points:

point G ($0.0061a^2 - 0.9918a + 63.902$, $-0.0061a^2 - 0.0082a + 36.098$, 0.0),

point I ($0.0061a^2-0.9918a+63.902$, 0.0 , $-0.0061a^2-0.0082a+36.098$),

point A ($0.0085a^2-1.8102a+67.1$, 0.0 , $-0.0085a^2+0.8102a+32.9$),

point B (0.0 , $0.0012a^2-1.1659a+52.95$, $-0.0012a^2+0.1659a+47.05$) and

point W (0.0 , $100.0-a$, 0.0),

or on the straight lines GI and AB (excluding point G, point I, point A, point B, and point W). When the refrigerant according to the present disclosure satisfies the above requirements, it has a refrigerating capacity ratio of 85% or more relative to that of R410A, and a COP ratio of 92.5% or more relative to that of R410A, and further ensures a WCF lower flammability.

[0416] The refrigerant C according to the present disclosure is preferably a refrigerant wherein

[0417] when the mass % of HFO-1132(E), HFO-1123, and R1234yf based on their sum is respectively represented by x, y, and z,

[0418] if $0 < a \leq 11.1$, coordinates (x,y,z) in a ternary composition diagram in which the sum of HFO-1132(E), HFO-1123, and R1234yf is (100-a) mass % are within the range of a figure surrounded by straight lines JK', K'B, BD', D'C, and CJ that connect the following 5 points:

point J ($0.0049a^2-0.9645a+47.1$, $-0.0049a^2-0.0355a+52.9$, 0.0),

point K' ($0.0514a^2-2.4353a+61.7$, $-0.0323a^2+0.4122a+5.9$, $-0.0191a^2+1.0231a+32.4$),

point B (0.0 , $0.0144a^2-1.6377a+58.7$, $-0.0144a^2+0.6377a+41.3$),

point D' (0.0 , $0.0224a^2+0.968a+75.4$, $-0.0224a^2-1.968a+24.6$), and

point C ($-0.2304a^2-0.4062a+32.9$, $0.2304a^2-0.5938a+67.1$, 0.0),

or on the straight lines JK', K'B, and D'C (excluding point J, point B, point D', and point C);

[0419] if $11.1 < a \leq 18.2$, coordinates (x,y,z) in the ternary composition diagram are within the range of a figure surrounded by straight lines JK', K'B, BW, and WJ that connect the following 4 points:

point J ($0.0243a^2-1.4161a+49.725$, $-0.0243a^2+0.4161a+50.275$, 0.0),

point K' ($0.0341a^2-2.1977a+61.187$, $-0.0236a^2+0.34a+5.636$, $-0.0105a^2+0.8577a+33.177$),

point B (0.0 , $0.0075a^2-1.5156a+58.199$, $-0.0075a^2+0.5156a+41.801$) and

point W (0.0 , $100.0-a$, 0.0),

or on the straight lines JK' and K'B (excluding point J, point B, and point W);

[0420] if $18.2 < a \leq 26.7$, coordinates (x,y,z) in the ternary composition diagram are within the range of a figure surrounded by straight lines JK', K'B, BW, and WJ that connect the following 4 points:

point J ($0.0246a^2-1.4476a+50.184$, $-0.0246a^2+0.4476a+49.816$, 0.0),

point K' ($0.0196a^2-1.7863a+58.515$, $-0.0079a^2-0.1136a+8.702$, $-0.0117a^2+0.8999a+32.783$),

point B (0.0 , $0.009a^2-1.6045a+59.318$, $-0.009a^2+0.6045a+40.682$) and

point W (0.0 , $100.0-a$, 0.0),

or on the straight lines JK' and K'B (excluding point J, point B, and point W);

[0421] if $26.7 < a \leq 36.7$, coordinates (x,y,z) in the ternary composition diagram are within the range of a figure sur-

rounded by straight lines JK', K'A, AB, BW, and WJ that connect the following 5 points:

point J ($0.0183a^2-1.1399a+46.493$, $-0.0183a^2+0.1399a+53.507$, 0.0),

point K' ($-0.0051a^2+0.0929a+25.95$, 0.0 , $0.0051a^2-1.0929a+74.05$),

point A ($0.0103a^2-1.9225a+68.793$, 0.0 , $-0.0103a^2+0.9225a+31.207$),

point B (0.0 , $0.0046a^2-1.41a+57.286$, $-0.0046a^2+0.41a+42.714$) and

point W (0.0 , $100.0-a$, 0.0),

or on the straight lines JK', K'A, and AB (excluding point J, point B, and point W); and

[0422] if $36.7 < a \leq 46.7$, coordinates (x,y,z) in the ternary composition diagram are within the range of a figure surrounded by straight lines JK', K'A, AB, BW, and WJ that connect the following 5 points:

point J ($-0.0134a^2+1.0956a+7.13$, $0.0134a^2-2.0956a+92.87$, 0.0),

point K' ($-1.892a+29.443$, 0.0 , $0.892a+70.557$),

point A ($0.0085a^2-1.8102a+67.1$, 0.0 , $-0.0085a^2+0.8102a+32.9$),

point B (0.0 , $0.0012a^2-1.1659a+52.95$, $-0.0012a^2+0.1659a+47.05$) and

point W (0.0 , $100.0-a$, 0.0),

or on the straight lines JK', K'A, and AB (excluding point J, point B, and point W). When the refrigerant according to the present disclosure satisfies the above requirements, it has a refrigerating capacity ratio of 85% or more relative to that of R410A, and a COP ratio of 92.5% or more relative to that of R410A. Additionally, the refrigerant has a WCF lower flammability and a WCF lower flammability, and is classified as "Class 2L," which is a lower flammable refrigerant according to the ASHRAE standard.

[0423] When the refrigerant C according to the present disclosure further contains R32 in addition to HFO-1132 (E), HFO-1123, and R1234yf, the refrigerant may be a refrigerant wherein when the mass % of HFO-1132(E), HFO-1123, R1234yf, and R32 based on their sum is respectively represented by x, y, z, and a,

[0424] if $0 < a \leq 10.0$, coordinates (x,y,z) in a ternary composition diagram in which the sum of HFO-1132(E), HFO-1123, and R1234yf is (100-a) mass % are within the range of a figure surrounded by straight lines that connect the following 4 points:

point a ($0.02a^2-2.46a+93.4$, 0 , $-0.02a^2+2.46a+6.6$),

point b' ($-0.008a^2-1.38a+56$, $0.018a^2-0.53a+26.3$, $-0.01a^2+1.91a+17.7$),

point c ($-0.016a^2+1.02a+77.6$, $0.016a^2-1.02a+22.4$, 0), and

point o ($100.0-a$, 0.0 , 0.0)

or on the straight lines oa, ab', and b'c (excluding point o and point c);

[0425] if $10.0 < a \leq 16.5$, coordinates (x,y,z) in the ternary composition diagram are within the range of a figure surrounded by straight lines that connect the following 4 points:

point a ($0.0244a^2-2.5695a+94.056$, 0 , $-0.0244a^2+2.5695a+5.944$),

point b' ($0.1161a^2-1.9959a+59.749$, $0.014a^2-0.3399a+24.8$, $-0.1301a^2+2.3358a+15.451$),

point c ($-0.0161a^2+1.02a+77.6$, $0.0161a^2-1.02a+22.4$, 0), and

point o ($100.0-a$, 0.0 , 0.0),

or on the straight lines oa, ab', and b'c (excluding point o and point c); or

[0426] if $16.5 < a \leq 21.8$, coordinates (x,y,z) in the ternary composition diagram are within the range of a figure surrounded by straight lines that connect the following 4 points: point a ($0.0161a^2 - 2.3535a + 92.742, 0, -0.0161a^2 + 2.3535a + 7.258$), point b' ($-0.0435a^2 - 0.0435a + 50.406, 0.0304a^2 + 1.8991a - 0.0661, 0.0739a^2 - 1.8556a + 49.6601$), point c ($-0.0161a^2 + 0.9959a + 77.851, 0.0161a^2 - 0.9959a + 22.149, 0$), and point o ($100.0 - a, 0.0, 0.0$), or on the straight lines oa, ab', and b'c (excluding point o and point c). Note that when point b in the ternary composition diagram is defined as a point where a refrigerating capacity ratio of 95% relative to that of R410A and a COP ratio of 95% relative to that of R410A are both achieved, point b' is the intersection of straight line ab and an approximate line formed by connecting the points where the COP ratio relative to that of R410A is 95%. When the refrigerant according to the present disclosure meets the above requirements, the refrigerant has a refrigerating capacity ratio of 95% or more relative to that of R410A, and a COP ratio of 95% or more relative to that of R410A.

[0427] The refrigerant C according to the present disclosure may further comprise other additional refrigerants in addition to HFO-1132(E), HFO-1123, R1234yf, and R32 as long as the above properties and effects are not impaired. In this respect, the refrigerant according to the present disclosure preferably comprises HFO-1132(E), HFO-1123, R1234yf, and R32 in a total amount of 99.5 mass % or more, more preferably 99.75 mass % or more, and still more preferably 99.9 mass % or more, based on the entire refrigerant.

[0428] The refrigerant C according to the present disclosure may comprise HFO-1132(E), HFO-1123, R1234yf, and R32 in a total amount of 99.5 mass % or more, 99.75 mass % or more, or 99.9 mass % or more, based on the entire refrigerant.

[0429] Additional refrigerants are not particularly limited and can be widely selected. The mixed refrigerant may contain one additional refrigerant, or two or more additional refrigerants.

(Examples of Refrigerant C)

[0430] The present disclosure is described in more detail below with reference to Examples of refrigerant C. However, the refrigerant C is not limited to the Examples.

[0431] Mixed refrigerants were prepared by mixing HFO-1132(E), HFO-1123, R1234yf, and R32 at mass % based on their sum shown in Tables 39 to 96.

[0432] The GWP of compositions each comprising a mixture of R410A (R32=50%/R125=50%) was evaluated based on the values stated in the Intergovernmental Panel on Climate Change (IPCC), fourth report. The GWP of HFO-1132(E), which was not stated therein, was assumed to be 1 from HFO-1132a (GWP=1 or less) and HFO-1123 (GWP=0.3, described in Patent Literature 1). The refrigerating capacity of compositions each comprising R410A and a mixture of HFO-1132(E) and HFO-1123 was determined by performing theoretical refrigeration cycle calculations for the mixed refrigerants using the National Institute of Science and Technology (NIST) and Reference Fluid Thermodynamic and Transport Properties Database (Refprop 9.0) under the following conditions.

[0433] For each of these mixed refrigerants, the COP ratio and the refrigerating capacity ratio relative to those of R410 were obtained. Calculation was conducted under the following conditions.

[0434] Evaporating temperature: 5° C.

[0435] Condensation temperature: 45° C.

[0436] Superheating temperature: 5 K

[0437] Subcooling temperature: 5 K

[0438] Compressor efficiency: 70%

[0439] Tables 39 to 96 show the resulting values together with the GWP of each mixed refrigerant. The COP and refrigerating capacity are ratios relative to R410A.

[0440] The coefficient of performance (COP) was determined by the following formula.

$$\text{COP} = \frac{\text{refrigerating capacity or heating capacity}}{\text{power consumption}}$$

TABLE 39

Item	Unit	Comp. Ex. 1	Comp.	Comp.	Comp.	Comp.	Comp.	Comp.	Comp.	Comp.
			Ex. 2	Ex. 3	Ex. 4	Ex. 5	Ex. 6	Ex. 7	Ex. 8	Ex. 1
			A	B	C	D'	G	I	J	K'
HFO-1132(E)	Mass %	R410A	68.6	0.0	32.9	0.0	72.0	72.0	47.1	61.7
HFO-1123	Mass %		0.0	58.7	67.1	75.4	28.0	0.0	52.9	5.9
R1234yf	Mass %		31.4	41.3	0.0	24.6	0.0	28.0	0.0	32.4
R32	Mass %		0.0	0.0	0.0	0.0	0.0	0.0	0.0	0.0
GWP	—	2088	2	2	1	2	1	2	1	2
COP ratio	% (relative to R410A)	100	100.0	95.5	92.5	93.1	96.6	99.9	93.8	99.4
Refrigerating capacity ratio	% (relative to R410A)	100	85.0	85.0	107.4	95.0	103.1	86.6	106.2	85.5

TABLE 40

Item	Unit	Comp.	Comp.	Comp.	Comp.	Comp.	Comp.	Comp.
		Ex. 9	Ex. 10	Ex. 11	Ex. 12	Ex. 13	Ex. 14	Ex. 15
		A	B	C	D'	G	I	J
HFO-1132(E)	Mass %	55.3	0.0	18.4	0.0	60.9	60.9	40.5
HFO-1123	Mass %	0.0	47.8	74.5	83.4	32.0	0.0	52.4

TABLE 40-continued

Item	Unit	Comp. Ex. 9 A	Comp. Ex. 10 B	Comp. Ex. 11 C	Comp. Ex. 12 D'	Comp. Ex. 13 G	Comp. Ex. 14 I	Comp. Ex. 15 J	Ex. 2 K'
R1234yf	Mass %	37.6	45.1	0.0	9.5	0.0	32.0	0.0	38.7
R32	Mass %	7.1	7.1	7.1	7.1	7.1	7.1	7.1	7.1
GWP	—	50	50	49	49	49	50	49	50
COP ratio	% (relative to R410A)	99.8	96.9	92.5	92.5	95.9	99.6	94.0	99.2
Refrigerating capacity ratio	% (relative to R410A)	85.0	85.0	110.5	106.0	106.5	87.7	108.9	85.5

TABLE 41

Item	Unit	Comp. Ex. 16 A	Comp. Ex. 17 B	Comp. Ex. 18 C = D'	Comp. Ex. 19 G	Comp. Ex. 20 I	Comp. Ex. 21 J	Ex. 3 K'
HFO-1132(E)	Mass %	48.4	0.0	0.0	55.8	55.8	37.0	41.0
HFO-1123	Mass %	0.0	42.3	88.9	33.1	0.0	51.9	6.5
R1234yf	Mass %	40.5	46.6	0.0	0.0	33.1	0.0	41.4
R32	Mass %	11.1	11.1	11.1	11.1	11.1	11.1	11.1
GWP	—	77	77	76	76	77	76	77
COP ratio	% (relative to R410A)	99.8	97.6	92.5	95.8	99.5	94.2	99.3
Refrigerating capacity ratio	% (relative to R410A)	85.0	85.0	112.0	108.0	88.6	110.2	85.4

TABLE 42

Item	Unit	Comp. Ex. 22 A	Comp. Ex. 23 B	Comp. Ex. 24 G	Comp. Ex. 25 I	Comp. Ex. 26 J	Ex. 4 K'
HFO-1132(E)	Mass %	42.8	0.0	52.1	52.1	34.3	36.5
HFO-1123	Mass %	0.0	37.8	33.4	0.0	51.2	5.6
R1234yf	Mass %	42.7	47.7	0.0	33.4	0.0	43.4
R32	Mass %	14.5	14.5	14.5	14.5	14.5	14.5
GWP	—	100	100	99	100	99	100
COP ratio	% (relative to R410A)	99.9	98.1	95.8	99.5	94.4	99.5
Refrigerating capacity ratio	% (relative to R410A)	85.0	85.0	109.1	89.6	111.1	85.3

TABLE 43

Item	Unit	Comp. Ex. 27 A	Comp. Ex. 28 B	Comp. Ex. 29 G	Comp. Ex. 30 I	Comp. Ex. 31 J	Ex. 5 K'
HFO-1132(E)	Mass %	37.0	0.0	48.6	48.6	32.0	32.5
HFO-1123	Mass %	0.0	33.1	33.2	0.0	49.8	4.0
R1234yf	Mass %	44.8	48.7	0.0	33.2	0.0	45.3
R32	Mass %	18.2	18.2	18.2	18.2	18.2	18.2
GWP	—	125	125	124	125	124	125
COP ratio	% (relative to R410A)	100.0	98.6	95.9	99.4	94.7	99.8
Refrigerating capacity ratio	% (relative to R410A)	85.0	85.0	110.1	90.8	111.9	85.2

TABLE 44

Item	Unit	Comp. Ex. 32 A	Comp. Ex. 33 B	Comp. Ex. 34 G	Comp. Ex. 35 I	Comp. Ex. 36 J	Ex. 6 K'
HFO-1132(E)	Mass %	31.5	0.0	45.4	45.4	30.3	28.8
HFO-1123	Mass %	0.0	28.5	32.7	0.0	47.8	2.4

TABLE 44-continued

Item	Unit	Comp.	Comp.	Comp.	Comp.	Comp.	Comp.
		Ex. 32 A	Ex. 33 B	Ex. 34 G	Ex. 35 I	Ex. 36 J	Ex. 6 K'
R1234yf	Mass %	46.6	49.6	0.0	32.7	0.0	46.9
R32	Mass %	21.9	21.9	21.9	21.9	21.9	21.9
GWP	—	150	150	149	150	149	150
COP ratio	% (relative to R410A)	100.2	99.1	96.0	99.4	95.1	100.0
Refrigerating capacity ratio	% (relative to R410A)	85.0	85.0	111.0	92.1	112.6	85.1

TABLE 45

Item	Unit	Comp.	Comp.	Comp.	Comp.	Comp.	Comp.
		Ex. 37 A	Ex. 38 B	Ex. 39 G	Ex. 40 I	Ex. 41 J	Ex. 42 K'
HFO-1132(E)	Mass %	24.8	0.0	41.8	41.8	29.1	24.8
HFO-1123	Mass %	0.0	22.9	31.5	0.0	44.2	0.0
R1234yf	Mass %	48.5	50.4	0.0	31.5	0.0	48.5
R32	Mass %	26.7	26.7	26.7	26.7	26.7	26.7
GWP	—	182	182	181	182	181	182
COP ratio	% (relative to R410A)	100.4	99.8	96.3	99.4	95.6	100.4
Refrigerating capacity ratio	% (relative to R410A)	85.0	85.0	111.9	93.8	113.2	85.0

TABLE 46

Item	Unit	Comp.	Comp.	Comp.	Comp.	Comp.	Comp.
		Ex. 43 A	Ex. 44 B	Ex. 45 G	Ex. 46 I	Ex. 47 J	Ex. 48 K'
HFO-1132(E)	Mass %	21.3	0.0	40.0	40.0	28.8	24.3
HFO-1123	Mass %	0.0	19.9	30.7	0.0	41.9	0.0
R1234yf	Mass %	49.4	50.8	0.0	30.7	0.0	46.4
R32	Mass %	29.3	29.3	29.3	29.3	29.3	29.3
GWP	—	200	200	198	199	198	200
COP ratio	% (relative to R410A)	100.6	100.1	96.6	99.5	96.1	100.4
Refrigerating capacity ratio	% (relative to R410A)	85.0	85.0	112.4	94.8	113.6	86.7

TABLE 47

Item	Unit	Comp.	Comp.	Comp.	Comp.	Comp.	Comp.
		Ex. 49 A	Ex. 50 B	Ex. 51 G	Ex. 52 I	Ex. 53 J	Ex. 54 K'
HFO-1132(E)	Mass %	12.1	0.0	35.7	35.7	29.3	22.5
HFO-1123	Mass %	0.0	11.7	27.6	0.0	34.0	0.0
R1234yf	Mass %	51.2	51.6	0.0	27.6	0.0	40.8
R32	Mass %	36.7	36.7	36.7	36.7	36.7	36.7
GWP	—	250	250	248	249	248	250
COP ratio	% (relative to R410A)	101.2	101.0	96.4	99.6	97.0	100.4
Refrigerating capacity ratio	% (relative to R410A)	85.0	85.0	113.2	97.6	113.9	90.9

TABLE 48

Item	Unit	Comp.	Comp.	Comp.	Comp.	Comp.	Comp.
		Ex. 55 A	Ex. 56 B	Ex. 57 G	Ex. 58 I	Ex. 59 J	Ex. 60 K'
HFO-1132(E)	Mass %	3.8	0.0	32.0	32.0	29.4	21.1
HFO-1123	Mass %	0.0	3.9	23.9	0.0	26.5	0.0

TABLE 48-continued

Item	Unit	Comp. Ex. 55 A	Comp. Ex. 56 B	Comp. Ex. 57 G	Comp. Ex. 58 I	Comp. Ex. 59 J	Comp. Ex. 60 K'
R1234yf	Mass %	52.1	52.0	0.0	23.9	0.0	34.8
R32	Mass %	44.1	44.1	44.1	44.1	44.1	44.1
GWP	—	300	300	298	299	298	299
COP ratio	% (relative to R410A)	101.8	101.8	97.9	99.8	97.8	100.5
Refrigerating capacity ratio	% (relative to R410A)	85.0	85.0	113.7	100.4	113.9	94.9

TABLE 49

Item	Unit	Comp. Ex. 61 A = B	Comp. Ex. 62 G	Comp. Ex. 63 I	Comp. Ex. 64 J	Comp. Ex. 65 K'
HFO-1132(E)	Mass %	0.0	30.4	30.4	28.9	20.4
HFO-1123	Mass %	0.0	21.8	0.0	23.3	0.0
R1234yf	Mass %	52.2	0.0	21.8	0.0	31.8
R32	Mass %	47.8	47.8	47.8	47.8	47.8
GWP	—	325	323	324	323	324
COP ratio	% (relative to R410A)	102.1	98.2	100.0	98.2	100.6
Refrigerating capacity ratio	% (relative to R410A)	85.0	113.8	101.8	113.9	96.8

TABLE 50

Item	Unit	Comp. Ex. 66	Ex. 7	Ex. 8	Ex. 9	Ex. 10	Ex. 11	Ex. 12	Ex. 13
HFO-1132(E)	Mass %	5.0	10.0	15.0	20.0	25.0	30.0	35.0	40.0
HFO-1123	Mass %	82.9	77.9	72.9	67.9	62.9	57.9	52.9	47.9
R1234yf	Mass %	5.0	5.0	5.0	5.0	5.0	5.0	5.0	5.0
R32	Mass %	7.1	7.1	7.1	7.1	7.1	7.1	7.1	7.1
GWP	—	49	49	49	49	49	49	49	49
COP ratio	% (relative to R410A)	92.4	92.6	92.8	93.1	93.4	93.7	94.1	94.5
Refrigerating capacity ratio	% (relative to R410A)	108.4	108.3	108.2	107.9	107.6	107.2	106.8	106.3

TABLE 51

Item	Unit	Ex. 14	Ex. 15	Ex. 16	Ex. 17	Comp. Ex. 67	Ex. 18	Ex. 19	Ex. 20
HFO-1132(E)	Mass %	45.0	50.0	55.0	60.0	65.0	10.0	15.0	20.0
HFO-1123	Mass %	42.9	37.9	32.9	27.9	22.9	72.9	67.9	62.9
R1234yf	Mass %	5.0	5.0	5.0	5.0	5.0	10.0	10.0	10.0
R32	Mass %	7.1	7.1	7.1	7.1	7.1	7.1	7.1	7.1
GWP	—	49	49	49	49	49	49	49	49
COP ratio	% (relative to R410A)	95.0	95.4	95.9	96.4	96.9	93.0	93.3	93.6
Refrigerating capacity ratio	% (relative to R410A)	105.8	105.2	104.5	103.9	103.1	105.7	105.5	105.2

TABLE 52

Item	Unit	Ex. 21	Ex. 22	Ex. 23	Ex. 24	Ex. 25	Ex. 26	Ex. 27	Ex. 28
HFO-1132(E)	Mass %	25.0	30.0	35.0	40.0	45.0	50.0	55.0	60.0
HFO-1123	Mass %	57.9	52.9	47.9	42.9	37.9	32.9	27.9	22.9
R1234yf	Mass %	10.0	10.0	10.0	10.0	10.0	10.0	10.0	10.0
R32	Mass %	7.1	7.1	7.1	7.1	7.1	7.1	7.1	7.1
GWP	—	49	49	49	49	49	49	49	49
COP ratio	% (relative to R410A)	93.9	94.2	94.6	95.0	95.5	96.0	96.4	96.9

TABLE 52-continued

Item	Unit	Ex. 21	Ex. 22	Ex. 23	Ex. 24	Ex. 25	Ex. 26	Ex. 27	Ex. 28
Refrigerating capacity ratio	% (relative to R410A)	104.9	104.5	104.1	103.6	103.0	102.4	101.7	101.0

TABLE 53

Item	Unit	Comp.							
		Ex. 68	Ex. 29	Ex. 30	Ex. 31	Ex. 32	Ex. 33	Ex. 34	Ex. 35
HFO-1132(E)	Mass %	65.0	10.0	15.0	20.0	25.0	30.0	35.0	40.0
HFO-1123	Mass %	17.9	67.9	62.9	57.9	52.9	47.9	42.9	37.9
R1234yf	Mass %	10.0	15.0	15.0	15.0	15.0	15.0	15.0	15.0
R32	Mass %	7.1	7.1	7.1	7.1	7.1	7.1	7.1	7.1
GWP	—	49	49	49	49	49	49	49	49
COP ratio	% (relative to R410A)	97.4	93.5	93.8	94.1	94.4	94.8	95.2	95.6
Refrigerating capacity ratio	% (relative to R410A)	100.3	102.9	102.7	102.5	102.1	101.7	101.2	100.7

TABLE 54

Item	Unit	Comp.							
		Ex. 36	Ex. 37	Ex. 38	Ex. 39	Ex. 69	Ex. 40	Ex. 41	Ex. 42
HFO-1132(E)	Mass %	45.0	50.0	55.0	60.0	65.0	10.0	15.0	20.0
HFO-1123	Mass %	32.9	27.9	22.9	17.9	12.9	62.9	57.9	52.9
R1234yf	Mass %	15.0	15.0	15.0	15.0	15.0	20.0	20.0	20.0
R32	Mass %	7.1	7.1	7.1	7.1	7.1	7.1	7.1	7.1
GWP	—	49	49	49	49	49	49	49	49
COP ratio	% (relative to R410A)	96.0	96.5	97.0	97.5	98.0	94.0	94.3	94.6
Refrigerating capacity ratio	% (relative to R410A)	100.1	99.5	98.9	98.1	97.4	100.1	99.9	99.6

TABLE 55

Item	Unit	Ex. 43	Ex. 44	Ex. 45	Ex. 46	Ex. 47	Ex. 48	Ex. 49	Ex. 50
HFO-1132(E)	Mass %	25.0	30.0	35.0	40.0	45.0	50.0	55.0	60.0
HFO-1123	Mass %	47.9	42.9	37.9	32.9	27.9	22.9	17.9	12.9
R1234yf	Mass %	20.0	20.0	20.0	20.0	20.0	20.0	20.0	20.0
R32	Mass %	7.1	7.1	7.1	7.1	7.1	7.1	7.1	7.1
GWP	—	49	49	49	49	49	49	49	49
COP ratio	% (relative to R410A)	95.0	95.3	95.7	96.2	96.6	97.1	97.6	98.1
Refrigerating capacity ratio	% (relative to R410A)	99.2	98.8	98.3	97.8	97.2	96.6	95.9	95.2

TABLE 56

Item	Unit	Comp.							
		Ex. 70	Ex. 51	Ex. 52	Ex. 53	Ex. 54	Ex. 55	Ex. 56	Ex. 57
HFO-1132(E)	Mass %	65.0	10.0	15.0	20.0	25.0	30.0	35.0	40.0
HFO-1123	Mass %	7.9	57.9	52.9	47.9	42.9	37.9	32.9	27.9
R1234yf	Mass %	20.0	25.0	25.0	25.0	25.0	25.0	25.0	25.0
R32	Mass %	7.1	7.1	7.1	7.1	7.1	7.1	7.1	7.1
GWP	—	49	50	50	50	50	50	50	50
COP ratio	% (relative to R410A)	98.6	94.6	94.9	95.2	95.5	95.9	96.3	96.8
Refrigerating capacity ratio	% (relative to R410A)	94.4	97.1	96.9	96.7	96.3	95.9	95.4	94.8

TABLE 57

Item	Unit	Ex. 58	Ex. 59	Ex. 60	Ex. 61	Comp. Ex. 71	Ex. 62	Ex. 63	Ex. 64
HFO-1132(E)	Mass %	45.0	50.0	55.0	60.0	65.0	10.0	15.0	20.0
HFO-1123	Mass %	7.1	7.1	7.1	7.1	7.1	7.1	7.1	7.1
R1234yf	Mass %	25.0	25.0	25.0	25.0	25.0	30.0	30.0	30.0
R32	Mass %	7.1	7.1	7.1	7.1	7.1	7.1	7.1	7.1
GWP	—	50	50	50	50	50	50	50	50
COP ratio	% (relative to R410A)	97.2	97.7	98.2	98.7	99.2	95.2	95.5	95.8
Refrigerating capacity ratio	% (relative to R410A)	94.2	93.6	92.9	92.2	91.4	94.2	93.9	93.7

TABLE 58

Item	Unit	Ex. 65	Ex. 66	Ex. 67	Ex. 68	Ex. 69	Ex. 70	Ex. 71	Ex. 72
HFO-1132(E)	Mass %	25.0	30.0	35.0	40.0	45.0	50.0	55.0	60.0
HFO-1123	Mass %	37.9	32.9	27.9	22.9	17.9	12.9	7.9	2.9
R1234yf	Mass %	30.0	30.0	30.0	30.0	30.0	30.0	30.0	30.0
R32	Mass %	7.1	7.1	7.1	7.1	7.1	7.1	7.1	7.1
GWP	—	50	50	50	50	50	50	50	50
COP ratio	% (relative to R410A)	96.2	96.6	97.0	97.4	97.9	98.3	98.8	99.3
Refrigerating capacity ratio	% (relative to R410A)	93.3	92.9	92.4	91.8	91.2	90.5	89.8	89.1

TABLE 59

Item	Unit	Ex. 73	Ex. 74	Ex. 75	Ex. 76	Ex. 77	Ex. 78	Ex. 79	Ex. 80
HFO-1132(E)	Mass %	10.0	15.0	20.0	25.0	30.0	35.0	40.0	45.0
HFO-1123	Mass %	47.9	42.9	37.9	32.9	27.9	22.9	17.9	12.9
R1234yf	Mass %	35.0	35.0	35.0	35.0	35.0	35.0	35.0	35.0
R32	Mass %	7.1	7.1	7.1	7.1	7.1	7.1	7.1	7.1
GWP	—	50	50	50	50	50	50	50	50
COP ratio	% (relative to R410A)	95.9	96.2	96.5	96.9	97.2	97.7	98.1	98.5
Refrigerating capacity ratio	% (relative to R410A)	91.1	90.9	90.6	90.2	89.8	89.3	88.7	88.1

TABLE 60

Item	Unit	Ex. 81	Ex. 82	Ex. 83	Ex. 84	Ex. 85	Ex. 86	Ex. 87	Ex. 88
HFO-1132(E)	Mass %	50.0	55.0	10.0	15.0	20.0	25.0	30.0	35.0
HFO-1123	Mass %	7.9	2.9	42.9	37.9	32.9	27.9	22.9	17.9
R1234yf	Mass %	35.0	35.0	40.0	40.0	40.0	40.0	40.0	40.0
R32	Mass %	7.1	7.1	7.1	7.1	7.1	7.1	7.1	7.1
GWP	—	50	50	50	50	50	50	50	50
COP ratio	% (relative to R410A)	99.0	99.4	96.6	96.9	97.2	97.6	98.0	98.4
Refrigerating capacity ratio	% (relative to R410A)	87.4	86.7	88.0	87.8	87.5	87.1	86.6	86.1

TABLE 61

Item	Unit	Comp. Ex. 72	Comp. Ex. 73	Comp. Ex. 74	Comp. Ex. 75	Comp. Ex. 76	Comp. Ex. 77	Comp. Ex. 78	Comp. Ex. 79
HFO-1132(E)	Mass %	40.0	45.0	50.0	10.0	15.0	20.0	25.0	30.0
HFO-1123	Mass %	12.9	7.9	2.9	37.9	32.9	27.9	22.9	17.9
R1234yf	Mass %	40.0	40.0	40.0	45.0	45.0	45.0	45.0	45.0
R32	Mass %	7.1	7.1	7.1	7.1	7.1	7.1	7.1	7.1
GWP	—	50	50	50	50	50	50	50	50
COP ratio	% (relative to R410A)	98.8	99.2	99.6	97.4	97.7	98.0	98.3	98.7

TABLE 61-continued

Item	Unit	Comp. Ex. 72	Comp. Ex. 73	Comp. Ex. 74	Comp. Ex. 75	Comp. Ex. 76	Comp. Ex. 77	Comp. Ex. 78	Comp. Ex. 79
Refrigerating capacity ratio	% (relative to R410A)	85.5	84.9	84.2	84.9	84.6	84.3	83.9	83.5

TABLE 62

Item	Unit	Comp. Ex. 80	Comp. Ex. 81	Comp. Ex. 82
HFO-1132(E)	Mass %	35.0	40.0	45.0
HFO-1123	Mass %	12.9	7.9	2.9
R1234yf	Mass %	45.0	45.0	45.0
R32	Mass %	7.1	7.1	7.1
GWP	—	50	50	50

TABLE 62-continued

Item	Unit	Comp. Ex. 80	Comp. Ex. 81	Comp. Ex. 82
COP ratio	% (relative to R410A)	99.1	99.5	99.9
Refrigerating capacity ratio	% (relative to R410A)	82.9	82.3	81.7

TABLE 63

Item	Unit	Ex. 89	Ex. 90	Ex. 91	Ex. 92	Ex. 93	Ex. 94	Ex. 95	Ex. 96
HFO-1132(E)	Mass %	10.0	15.0	20.0	25.0	30.0	35.0	40.0	45.0
HFO-1123	Mass %	70.5	65.5	60.5	55.5	50.5	45.5	40.5	35.5
R1234yf	Mass %	5.0	5.0	5.0	5.0	5.0	5.0	5.0	5.0
R32	Mass %	14.5	14.5	14.5	14.5	14.5	14.5	14.5	14.5
GWP	—	99	99	99	99	99	99	99	99
COP ratio	% (relative to R410A)	93.7	93.9	94.1	94.4	94.7	95.0	95.4	95.8
Refrigerating capacity ratio	% (relative to R410A)	110.2	110.0	109.7	109.3	108.9	108.4	107.9	107.3

TABLE 64

Item	Unit	Ex. 97	Comp. Ex. 83	Ex. 98	Ex. 99	Ex. 100	Ex. 101	Ex. 102	Ex. 103
HFO-1132(E)	Mass %	50.0	55.0	10.0	15.0	20.0	25.0	30.0	35.0
HFO-1123	Mass %	30.5	25.5	65.5	60.5	55.5	50.5	45.5	40.5
R1234yf	Mass %	5.0	5.0	10.0	10.0	10.0	10.0	10.0	10.0
R32	Mass %	14.5	14.5	14.5	14.5	14.5	14.5	14.5	14.5
GWP	—	99	99	99	99	99	99	99	99
COP ratio	% (relative to R410A)	96.2	96.6	94.2	94.4	94.6	94.9	95.2	95.5
Refrigerating capacity ratio	% (relative to R410A)	106.6	106.0	107.5	107.3	107.0	106.6	106.1	105.6

TABLE 65

Item	Unit	Ex. 104	Ex. 105	Ex. 106	Comp. Ex. 84	Ex. 107	Ex. 108	Ex. 109	Ex. 110
HFO-1132(E)	Mass %	40.0	45.0	50.0	55.0	10.0	15.0	20.0	25.0
HFO-1123	Mass %	35.5	30.5	25.5	20.5	60.5	55.5	50.5	45.5
R1234yf	Mass %	10.0	10.0	10.0	10.0	15.0	15.0	15.0	15.0
R32	Mass %	14.5	14.5	14.5	14.5	14.5	14.5	14.5	14.5
GWP	—	99	99	99	99	99	99	99	99
COP ratio	% (relative to R410A)	95.9	96.3	96.7	97.1	94.6	94.8	95.1	95.4
Refrigerating capacity ratio	% (relative to R410A)	105.1	104.5	103.8	103.1	104.7	104.5	104.1	103.7

TABLE 66

Item	Unit	Ex. 111	Ex. 112	Ex. 113	Ex. 114	Ex. 115	Comp. Ex. 85	Ex. 116	Ex. 117
HFO-1132(E)	Mass %	30.0	35.0	40.0	45.0	50.0	55.0	10.0	15.0
HFO-1123	Mass %	40.5	35.5	30.5	25.5	20.5	15.5	55.5	50.5

TABLE 66-continued

Item	Unit	Ex. 111	Ex. 112	Ex. 113	Ex. 114	Ex. 115	Comp.		
							Ex. 85	Ex. 116	Ex. 117
R1234yf	Mass %	15.0	15.0	15.0	15.0	15.0	15.0	20.0	20.0
R32	Mass %	14.5	14.5	14.5	14.5	14.5	14.5	14.5	14.5
GWP	—	99	99	99	99	99	99	99	99
COP ratio	% (relative to R410A)	95.7	96.0	96.4	96.8	97.2	97.6	95.1	95.3
Refrigerating capacity ratio	% (relative to R410A)	103.3	102.8	102.2	101.6	101.0	100.3	101.8	101.6

TABLE 67

Item	Unit	Ex. 118	Ex. 119	Ex. 120	Ex. 121	Ex. 122	Ex. 123	Ex. 124	Comp.
									Ex. 86
HFO-1132(E)	Mass %	20.0	25.0	30.0	35.0	40.0	45.0	50.0	55.0
HFO-1123	Mass %	45.5	40.5	35.5	30.5	25.5	20.5	15.5	10.5
R1234yf	Mass %	20.0	20.0	20.0	20.0	20.0	20.0	20.0	20.0
R32	Mass %	14.5	14.5	14.5	14.5	14.5	14.5	14.5	14.5
GWP	—	99	99	99	99	99	99	99	99
COP ratio	% (relative to R410A)	95.6	95.9	96.2	96.5	96.9	97.3	97.7	98.2
Refrigerating capacity ratio	% (relative to R410A)	101.2	100.8	100.4	99.9	99.3	98.7	98.0	97.3

TABLE 68

Item	Unit	Ex. 125	Ex. 126	Ex. 127	Ex. 128	Ex. 129	Ex. 130	Ex. 131	Ex. 132
									Ex. 132
HFO-1132(E)	Mass %	10.0	15.0	20.0	25.0	30.0	35.0	40.0	45.0
HFO-1123	Mass %	50.5	45.5	40.5	35.5	30.5	25.5	20.5	15.5
R1234yf	Mass %	25.0	25.0	25.0	25.0	25.0	25.0	25.0	25.0
R32	Mass %	14.5	14.5	14.5	14.5	14.5	14.5	14.5	14.5
GWP	—	99	99	99	99	99	99	99	99
COP ratio	% (relative to R410A)	95.6	95.9	96.1	96.4	96.7	97.1	97.5	97.9
Refrigerating capacity ratio	% (relative to R410A)	98.9	98.6	98.3	97.9	97.4	96.9	96.3	95.7

TABLE 69

Item	Unit	Ex. 133	Comp.						
			Ex. 87	Ex. 134	Ex. 135	Ex. 136	Ex. 137	Ex. 138	Ex. 139
HFO-1132(E)	Mass %	50.0	55.0	10.0	15.0	20.0	25.0	30.0	35.0
HFO-1123	Mass %	10.5	5.5	45.5	40.5	35.5	30.5	25.5	20.5
R1234yf	Mass %	25.0	25.0	30.0	30.0	30.0	30.0	30.0	30.0
R32	Mass %	14.5	14.5	14.5	14.5	14.5	14.5	14.5	14.5
GWP	—	99	99	100	100	100	100	100	100
COP ratio	% (relative to R410A)	98.3	98.7	96.2	96.4	96.7	97.0	97.3	97.7
Refrigerating capacity ratio	% (relative to R410A)	95.0	94.3	95.8	95.6	95.2	94.8	94.4	93.8

TABLE 70

Item	Unit	Ex. 140	Ex. 141	Ex. 142	Ex. 143	Ex. 144	Ex. 145	Ex. 146	Ex. 147
									Ex. 147
HFO-1132(E)	Mass %	40.0	45.0	50.0	10.0	15.0	20.0	25.0	30.0
HFO-1123	Mass %	15.5	10.5	5.5	40.5	35.5	30.5	25.5	20.5
R1234yf	Mass %	30.0	30.0	30.0	35.0	35.0	35.0	35.0	35.0
R32	Mass %	14.5	14.5	14.5	14.5	14.5	14.5	14.5	14.5
GWP	—	100	100	100	100	100	100	100	100
COP ratio	% (relative to R410A)	98.1	98.5	98.9	96.8	97.0	97.3	97.6	97.9
Refrigerating capacity ratio	% (relative to R410A)	93.3	92.6	92.0	92.8	92.5	92.2	91.8	91.3

TABLE 71

Item	Unit	Ex. 148	Ex. 149	Ex. 150	Ex. 151	Ex. 152	Ex. 153	Ex. 154	Ex. 155
HFO-1132(E)	Mass %	35.0	40.0	45.0	10.0	15.0	20.0	25.0	30.0
HFO-1123	Mass %	15.5	10.5	5.5	35.5	30.5	25.5	20.5	15.5
R1234yf	Mass %	35.0	35.0	35.0	40.0	40.0	40.0	40.0	40.0
R32	Mass %	14.5	14.5	14.5	14.5	14.5	14.5	14.5	14.5
GWP	—	100	100	100	100	100	100	100	100
COP ratio	% (relative to R410A)	98.3	98.7	99.1	97.4	97.7	98.0	98.3	98.6
Refrigerating capacity ratio	% (relative to R410A)	90.8	90.2	89.6	89.6	89.4	89.0	88.6	88.2

TABLE 72

Item	Unit	Ex. 156	Ex. 157	Ex. 158	Ex. 159	Ex. 160	Comp. Ex. 88	Comp. Ex. 89	Comp. Ex. 90
HFO-1132(E)	Mass %	35.0	40.0	10.0	15.0	20.0	25.0	30.0	35.0
HFO-1123	Mass %	10.5	5.5	30.5	25.5	20.5	15.5	10.5	5.5
R1234yf	Mass %	40.0	40.0	45.0	45.0	45.0	45.0	45.0	45.0
R32	Mass %	14.5	14.5	14.5	14.5	14.5	14.5	14.5	14.5
GWP	—	100	100	100	100	100	100	100	100
COP ratio	% (relative to R410A)	98.9	99.3	98.1	98.4	98.7	98.9	99.3	99.6
Refrigerating capacity ratio	% (relative to R410A)	87.6	87.1	86.5	86.2	85.9	85.5	85.0	84.5

TABLE 73

Item	Unit	Comp. Ex. 91	Comp. Ex. 92	Comp. Ex. 93	Comp. Ex. 94	Comp. Ex. 95
HFO-1132(E)	Mass %	10.0	15.0	20.0	25.0	30.0
HFO-1123	Mass %	25.5	20.5	15.5	10.5	5.5
R1234yf	Mass %	50.0	50.0	50.0	50.0	50.0
R32	Mass %	14.5	14.5	14.5	14.5	14.5
GWP	—	100	100	100	100	100
COP ratio	% (relative to R410A)	98.9	99.1	99.4	99.7	100.0
Refrigerating capacity ratio	% (relative to R410A)	83.3	83.0	82.7	82.2	81.8

TABLE 74

Item	Unit	Ex. 161	Ex. 162	Ex. 163	Ex. 164	Ex. 165	Ex. 166	Ex. 167	Ex. 168
HFO-1132(E)	Mass %	10.0	15.0	20.0	25.0	30.0	35.0	40.0	45.0
HFO-1123	Mass %	63.1	58.1	53.1	48.1	43.1	38.1	33.1	28.1
R1234yf	Mass %	5.0	5.0	5.0	5.0	5.0	5.0	5.0	5.0
R32	Mass %	21.9	21.9	21.9	21.9	21.9	21.9	21.9	21.9
GWP	—	149	149	149	149	149	149	149	149
COP ratio	% (relative to R410A)	94.8	95.0	95.2	95.4	95.7	95.9	96.2	96.6
Refrigerating capacity ratio	% (relative to R410A)	111.5	111.2	110.9	110.5	110.0	109.5	108.9	108.3

TABLE 75

Item	Unit	Comp. Ex. 96	Ex. 169	Ex. 170	Ex. 171	Ex. 172	Ex. 173	Ex. 174	Ex. 175
HFO-1132(E)	Mass %	50.0	10.0	15.0	20.0	25.0	30.0	35.0	40.0
HFO-1123	Mass %	23.1	58.1	53.1	48.1	43.1	38.1	33.1	28.1
R1234yf	Mass %	5.0	10.0	10.0	10.0	10.0	10.0	10.0	10.0
R32	Mass %	21.9	21.9	21.9	21.9	21.9	21.9	21.9	21.9
GWP	—	149	149	149	149	149	149	149	149
COP ratio	% (relative to R410A)	96.9	95.3	95.4	95.6	95.8	96.1	96.4	96.7

TABLE 75-continued

Item	Unit	Comp.							
		Ex. 96	Ex. 169	Ex. 170	Ex. 171	Ex. 172	Ex. 173	Ex. 174	Ex. 175
Refrigerating capacity ratio	% (relative to R410A)	107.7	108.7	108.5	108.1	107.7	107.2	106.7	106.1

TABLE 76

Item	Unit	Comp.							
		Ex. 176	Ex. 97	Ex. 177	Ex. 178	Ex. 179	Ex. 180	Ex. 181	Ex. 182
HFO-1132(E)	Mass %	45.0	50.0	10.0	15.0	20.0	25.0	30.0	35.0
HFO-1123	Mass %	23.1	18.1	53.1	48.1	43.1	38.1	33.1	28.1
R1234yf	Mass %	10.0	10.0	15.0	15.0	15.0	15.0	15.0	15.0
R32	Mass %	21.9	21.9	21.9	21.9	21.9	21.9	21.9	21.9
GWP	—	149	149	149	149	149	149	149	149
COP ratio	% (relative to R410A)	97.0	97.4	95.7	95.9	96.1	96.3	96.6	96.9
Refrigerating capacity ratio	% (relative to R410A)	105.5	104.9	105.9	105.6	105.3	104.8	104.4	103.8

TABLE 77

Item	Unit	Comp.							
		Ex. 183	Ex. 184	Ex. 98	Ex. 185	Ex. 186	Ex. 187	Ex. 188	Ex. 189
HFO-1132(E)	Mass %	40.0	45.0	50.0	10.0	15.0	20.0	25.0	30.0
HFO-1123	Mass %	23.1	18.1	13.1	48.1	43.1	38.1	33.1	28.1
R1234yf	Mass %	15.0	15.0	15.0	20.0	20.0	20.0	20.0	20.0
R32	Mass %	21.9	21.9	21.9	21.9	21.9	21.9	21.9	21.9
GWP	—	149	149	149	149	149	149	149	149
COP ratio	% (relative to R410A)	97.2	97.5	97.9	96.1	96.3	96.5	96.8	97.1
Refrigerating capacity ratio	% (relative to R410A)	103.3	102.6	102.0	103.0	102.7	102.3	101.9	101.4

TABLE 78

Item	Unit	Comp.							
		Ex. 190	Ex. 191	Ex. 192	Ex. 99	Ex. 193	Ex. 194	Ex. 195	Ex. 196
HFO-1132(E)	Mass %	35.0	40.0	45.0	50.0	10.0	15.0	20.0	25.0
HFO-1123	Mass %	23.1	18.1	13.1	8.1	43.1	38.1	33.1	28.1
R1234yf	Mass %	20.0	20.0	20.0	20.0	25.0	25.0	25.0	25.0
R32	Mass %	21.9	21.9	21.9	21.9	21.9	21.9	21.9	21.9
GWP	—	149	149	149	149	149	149	149	149
COP ratio	% (relative to R410A)	97.4	97.7	98.0	98.4	96.6	96.8	97.0	97.3
Refrigerating capacity ratio	% (relative to R410A)	100.9	100.3	99.7	99.1	100.0	99.7	99.4	98.9

TABLE 79

Item	Unit	Comp.							
		Ex. 197	Ex. 198	Ex. 199	Ex. 200	Ex. 100	Ex. 201	Ex. 202	Ex. 203
HFO-1132(E)	Mass %	30.0	35.0	40.0	45.0	50.0	10.0	15.0	20.0
HFO-1123	Mass %	23.1	18.1	13.1	8.1	3.1	38.1	33.1	28.1
R1234yf	Mass %	25.0	25.0	25.0	25.0	25.0	30.0	30.0	30.0
R32	Mass %	21.9	21.9	21.9	21.9	21.9	21.9	21.9	21.9
GWP	—	149	149	149	149	149	150	150	150
COP ratio	% (relative to R410A)	97.6	97.9	98.2	98.5	98.9	97.1	97.3	97.6
Refrigerating capacity ratio	% (relative to R410A)	98.5	97.9	97.4	96.8	96.1	97.0	96.7	96.3

TABLE 80

Item	Unit	Ex. 204	Ex. 205	Ex. 206	Ex. 207	Ex. 208	Ex. 209	Ex. 210	Ex. 211
HFO-1132(E)	Mass %	25.0	30.0	35.0	40.0	45.0	10.0	15.0	20.0
HFO-1123	Mass %	23.1	18.1	13.1	8.1	3.1	33.1	28.1	23.1
R1234yf	Mass %	30.0	30.0	30.0	30.0	30.0	35.0	35.0	35.0
R32	Mass %	21.9	21.9	21.9	21.9	21.9	21.9	21.9	21.9
GWP	—	150	150	150	150	150	150	150	150
COP ratio	% (relative to R410A)	97.8	98.1	98.4	98.7	99.1	97.7	97.9	98.1
Refrigerating capacity ratio	% (relative to R410A)	95.9	95.4	94.9	94.4	93.8	93.9	93.6	93.3

TABLE 81

Item	Unit	Ex. 212	Ex. 213	Ex. 214	Ex. 215	Ex. 216	Ex. 217	Ex. 218	Ex. 219
HFO-1132(E)	Mass %	25.0	30.0	35.0	40.0	10.0	15.0	20.0	25.0
HFO-1123	Mass %	18.1	13.1	8.1	3.1	28.1	23.1	18.1	13.1
R1234yf	Mass %	35.0	35.0	35.0	35.0	40.0	40.0	40.0	40.0
R32	Mass %	21.9	21.9	21.9	21.9	21.9	21.9	21.9	21.9
GWP	—	150	150	150	150	150	150	150	150
COP ratio	% (relative to R410A)	98.4	98.7	99.0	99.3	98.3	98.5	98.7	99.0
Refrigerating capacity ratio	% (relative to R410A)	92.9	92.4	91.9	91.3	90.8	90.5	90.2	89.7

TABLE 82

Item	Unit	Ex. 220	Ex. 221	Ex. 222	Ex. 223	Ex. 224	Ex. 225	Ex. 226	Comp. Ex. 101
HFO-1132(E)	Mass %	30.0	35.0	10.0	15.0	20.0	25.0	30.0	10.0
HFO-1123	Mass %	8.1	3.1	23.1	18.1	13.1	8.1	3.1	18.1
R1234yf	Mass %	40.0	40.0	45.0	45.0	45.0	45.0	45.0	50.0
R32	Mass %	21.9	21.9	21.9	21.9	21.9	21.9	21.9	21.9
GWP	—	150	150	150	150	150	150	150	150
COP ratio	% (relative to R410A)	99.3	99.6	98.9	99.1	99.3	99.6	99.9	99.6
Refrigerating capacity ratio	% (relative to R410A)	89.3	88.8	87.6	87.3	87.0	86.6	86.2	84.4

TABLE 83

Item	Unit	Comp. Ex. 102	Comp. Ex. 103	Comp. Ex. 104
HFO-1132(E)	Mass %	15.0	20.0	25.0
HFO-1123	Mass %	13.1	8.1	3.1
R1234yf	Mass %	50.0	50.0	50.0
R32	Mass %	21.9	21.9	21.9
GWP	—	150	150	150

TABLE 83-continued

Item	Unit	Comp. Ex. 102	Comp. Ex. 103	Comp. Ex. 104
COP ratio	% (relative to R410A)	99.8	100.0	100.2
Refrigerating capacity ratio	% (relative to R410A)	84.1	83.8	83.4

TABLE 84

Item	Unit	Ex. 227	Ex. 228	Ex. 229	Ex. 230	Ex. 231	Ex. 232	Ex. 233	Comp. Ex. 105
HFO-1132(E)	Mass %	10.0	15.0	20.0	25.0	30.0	35.0	40.0	45.0
HFO-1123	Mass %	55.7	50.7	45.7	40.7	35.7	30.7	25.7	20.7
R1234yf	Mass %	5.0	5.0	5.0	5.0	5.0	5.0	5.0	5.0
R32	Mass %	29.3	29.3	29.3	29.3	29.3	29.3	29.3	29.3
GWP	—	199	199	199	199	199	199	199	199
COP ratio	% (relative to R410A)	95.9	96.0	96.2	96.3	96.6	96.8	97.1	97.3
Refrigerating capacity ratio	% (relative to R410A)	112.2	111.9	111.6	111.2	110.7	110.2	109.6	109.0

TABLE 85

Item	Unit	Ex. 234	Ex. 235	Ex. 236	Ex. 237	Ex. 238	Ex. 239	Ex. 240	Comp. Ex. 106
HFO-1132(E)	Mass %	10.0	15.0	20.0	25.0	30.0	35.0	40.0	45.0
HFO-1123	Mass %	50.7	45.7	40.7	35.7	30.7	25.7	20.7	15.7
R1234yf	Mass %	10.0	10.0	10.0	10.0	10.0	10.0	10.0	10.0
R32	Mass %	29.3	29.3	29.3	29.3	29.3	29.3	29.3	29.3
GWP	—	199	199	199	199	199	199	199	199
COP ratio	% (relative to R410A)	96.3	96.4	96.6	96.8	97.0	97.2	97.5	97.8
Refrigerating capacity ratio	% (relative to R410A)	109.4	109.2	108.8	108.4	107.9	107.4	106.8	106.2

TABLE 86

Item	Unit	Ex. 241	Ex. 242	Ex. 243	Ex. 244	Ex. 245	Ex. 246	Ex. 247	Comp. Ex. 107
HFO-1132(E)	Mass %	10.0	15.0	20.0	25.0	30.0	35.0	40.0	45.0
HFO-1123	Mass %	45.7	40.7	35.7	30.7	25.7	20.7	15.7	10.7
R1234yf	Mass %	15.0	15.0	15.0	15.0	15.0	15.0	15.0	15.0
R32	Mass %	29.3	29.3	29.3	29.3	29.3	29.3	29.3	29.3
GWP	—	199	199	199	199	199	199	199	199
COP ratio	% (relative to R410A)	96.7	96.8	97.0	97.2	97.4	97.7	97.9	98.2
Refrigerating capacity ratio	% (relative to R410A)	106.6	106.3	106.0	105.5	105.1	104.5	104.0	103.4

TABLE 87

Item	Unit	Ex. 248	Ex. 249	Ex. 250	Ex. 251	Ex. 252	Ex. 253	Ex. 254	Comp. Ex. 108
HFO-1132(E)	Mass %	10.0	15.0	20.0	25.0	30.0	35.0	40.0	45.0
HFO-1123	Mass %	40.7	35.7	30.7	25.7	20.7	15.7	10.7	5.7
R1234yf	Mass %	20.0	20.0	20.0	20.0	20.0	20.0	20.0	20.0
R32	Mass %	29.3	29.3	29.3	29.3	29.3	29.3	29.3	29.3
GWP	—	199	199	199	199	199	199	199	199
COP ratio	% (relative to R410A)	97.1	97.3	97.5	97.7	97.9	98.1	98.4	98.7
Refrigerating capacity ratio	% (relative to R410A)	103.7	103.4	103.0	102.6	102.2	101.6	101.1	100.5

TABLE 88

Item	Unit	Ex. 255	Ex. 256	Ex. 257	Ex. 258	Ex. 259	Ex. 260	Ex. 261	Ex. 262
HFO-1132(E)	Mass %	10.0	15.0	20.0	25.0	30.0	35.0	40.0	10.0
HFO-1123	Mass %	35.7	30.7	25.7	20.7	15.7	10.7	5.7	30.7
R1234yf	Mass %	25.0	25.0	25.0	25.0	25.0	25.0	25.0	30.0
R32	Mass %	29.3	29.3	29.3	29.3	29.3	29.3	29.3	29.3
GWP	—	199	199	199	199	199	199	199	199
COP ratio	% (relative to R410A)	97.6	97.7	97.9	98.1	98.4	98.6	98.9	98.1
Refrigerating capacity ratio	% (relative to R410A)	100.7	100.4	100.1	99.7	99.2	98.7	98.2	97.7

TABLE 89

Item	Unit	Ex. 263	Ex. 264	Ex. 265	Ex. 266	Ex. 267	Ex. 268	Ex. 269	Ex. 270
HFO-1132(E)	Mass %	15.0	20.0	25.0	30.0	35.0	10.0	15.0	20.0
HFO-1123	Mass %	25.7	20.7	15.7	10.7	5.7	25.7	20.7	15.7
R1234yf	Mass %	30.0	30.0	30.0	30.0	30.0	35.0	35.0	35.0
R32	Mass %	29.3	29.3	29.3	29.3	29.3	29.3	29.3	29.3
GWP	—	199	199	199	199	199	200	200	200
COP ratio	% (relative to R410A)	98.2	98.4	98.6	98.9	99.1	98.6	98.7	98.9

TABLE 89-continued

Item	Unit	Ex. 263	Ex. 264	Ex. 265	Ex. 266	Ex. 267	Ex. 268	Ex. 269	Ex. 270
Refrigerating capacity ratio	% (relative to R410A)	97.4	97.1	96.7	96.2	95.7	94.7	94.4	94.0

TABLE 90

Item	Unit	Ex. 271	Ex. 272	Ex. 273	Ex. 274	Ex. 275	Ex. 276	Ex. 277	Ex. 278
HFO-1132(E)	Mass %	25.0	30.0	10.0	15.0	20.0	25.0	10.0	15.0
HFO-1123	Mass %	10.7	5.7	20.7	15.7	10.7	5.7	15.7	10.7
R1234yf	Mass %	35.0	35.0	40.0	40.0	40.0	40.0	45.0	45.0
R32	Mass %	29.3	29.3	29.3	29.3	29.3	29.3	29.3	29.3
GWP	—	200	200	200	200	200	200	200	200
COP ratio	% (relative to R410A)	99.2	99.4	99.1	99.3	99.5	99.7	99.7	99.8
Refrigerating capacity ratio	% (relative to R410A)	93.6	93.2	91.5	91.3	90.9	90.6	88.4	88.1

TABLE 91

Item	Unit	Ex. 279	Ex. 280	Comp. Ex. 109	Comp. Ex. 110
HFO-1132(E)	Mass %	20.0	10.0	15.0	10.0
HFO-1123	Mass %	5.7	10.7	5.7	5.7
R1234yf	Mass %	45.0	50.0	50.0	55.0
R32	Mass %	29.3	29.3	29.3	29.3
GWP	—	200	200	200	200

TABLE 91-continued

Item	Unit	Ex. 279	Ex. 280	Comp. Ex. 109	Comp. Ex. 110
COP ratio	% (relative to R410A)	100.0	100.3	100.4	100.9
Refrigerating capacity ratio	% (relative to R410A)	87.8	85.2	85.0	82.0

TABLE 92

Item	Unit	Ex. 281	Ex. 282	Ex. 283	Ex. 284	Ex. 285	Comp. Ex. 111	Ex. 286	Ex. 287
HFO-1132(E)	Mass %	10.0	15.0	20.0	25.0	30.0	35.0	10.0	15.0
HFO-1123	Mass %	40.9	35.9	30.9	25.9	20.9	15.9	35.9	30.9
R1234yf	Mass %	5.0	5.0	5.0	5.0	5.0	5.0	10.0	10.0
R32	Mass %	44.1	44.1	44.1	44.1	44.1	44.1	44.1	44.1
GWP	—	298	298	298	298	298	298	299	299
COP ratio	% (relative to R410A)	97.8	97.9	97.9	98.1	98.2	98.4	98.2	98.2
Refrigerating capacity ratio	% (relative to R410A)	112.5	112.3	111.9	111.6	111.2	110.7	109.8	109.5

TABLE 93

Item	Unit	Ex. 288	Ex. 289	Ex. 290	Comp. Ex. 112	Ex. 291	Ex. 292	Ex. 293	Ex. 294
HFO-1132(E)	Mass %	20.0	25.0	30.0	35.0	10.0	15.0	20.0	25.0
HFO-1123	Mass %	25.9	20.9	15.9	10.9	30.9	25.9	20.9	15.9
R1234yf	Mass %	10.0	10.0	10.0	10.0	15.0	15.0	15.0	15.0
R32	Mass %	44.1	44.1	44.1	44.1	44.1	44.1	44.1	44.1
GWP	—	299	299	299	299	299	299	299	299
COP ratio	% (relative to R410A)	98.3	98.5	98.6	98.8	98.6	98.6	98.7	98.9
Refrigerating capacity ratio	% (relative to R410A)	109.2	108.8	108.4	108.0	107.0	106.7	106.4	106.0

TABLE 94

Item	Unit	Ex. 295	Comp. Ex. 113	Ex. 296	Ex. 297	Ex. 298	Ex. 299	Ex. 300	Ex. 301
HFO-1132(E)	Mass %	30.0	35.0	10.0	15.0	20.0	25.0	30.0	10.0
HFO-1123	Mass %	10.9	5.9	25.9	20.9	15.9	10.9	5.9	20.9

TABLE 94-continued

Item	Unit	Comp.							
		Ex. 295	Ex. 113	Ex. 296	Ex. 297	Ex. 298	Ex. 299	Ex. 300	Ex. 301
R1234yf	Mass %	15.0	15.0	20.0	20.0	20.0	20.0	20.0	25.0
R32	Mass %	44.1	44.1	44.1	44.1	44.1	44.1	44.1	44.1
GWP	—	299	299	299	299	299	299	299	299
COP ratio	% (relative to R410A)	99.0	99.2	99.0	99.0	99.2	99.3	99.4	99.4
Refrigerating capacity ratio	% (relative to R410A)	105.6	105.2	104.1	103.9	103.6	103.2	102.8	101.2

TABLE 95

Item	Unit	Comp.							
		Ex. 302	Ex. 303	Ex. 304	Ex. 305	Ex. 306	Ex. 307	Ex. 308	Ex. 309
HFO-1132(E)	Mass %	15.0	20.0	25.0	10.0	15.0	20.0	10.0	15.0
HFO-1123	Mass %	15.9	10.9	5.9	15.9	10.9	5.9	10.9	5.9
R1234yf	Mass %	25.0	25.0	25.0	30.0	30.0	30.0	35.0	35.0
R32	Mass %	44.1	44.1	44.1	44.1	44.1	44.1	44.1	44.1
GWP	—	299	299	299	299	299	299	299	299
COP ratio	% (relative to R410A)	99.5	99.6	99.7	99.8	99.9	100.0	100.3	100.4
Refrigerating capacity ratio	% (relative to R410A)	101.0	100.7	100.3	98.3	98.0	97.8	95.3	95.1

TABLE 96

Item	Unit	Ex. 400
HFO-1132(E)	Mass %	10.0
HFO-1123	Mass %	5.9
R1234yf	Mass %	40.0
R32	Mass %	44.1
GWP	—	299
COP ratio	% (relative to R410A)	100.7
Refrigerating capacity ratio	% (relative to R410A)	92.3

[0441] The above results indicate that the refrigerating capacity ratio relative to R410A is 85% or more in the following cases:

[0442] When the mass % of HFO-1132(E), HFO-1123, R1234yf, and R32 based on their sum is respectively represented by x, y, z, and a, in a ternary composition diagram in which the sum of HFO-1132(E), HFO-1123, and R1234yf is (100-a) mass %, a straight line connecting a point (0.0, 100.0-a, 0.0) and a point (0.0, 0.0, 100.0-a) is the base, and the point (0.0, 100.0-a, 0.0) is on the left side, if 0<a≤11.1, coordinates (x,y,z) in the ternary composition diagram are on, or on the left side of, a straight line AB that connects point A (0.0134a²-1.9681a+68.6, 0.0, -0.0134a²+0.9681a+31.4) and point B (0.0, 0.0144a²-1.6377a+58.7, -0.0144a²+0.6377a+41.3);

[0443] if 11.1<a≤18.2, coordinates (x,y,z) in the ternary composition diagram are on, or on the left side of, a straight line AB that connects point A (0.0112a²-1.9337a+68.484, 0.0, -0.0112a²+0.9337a+31.516) and point B (0.0, 0.0075a²-1.5156a+58.199, -0.0075a²+0.5156a+41.801);

[0444] if 18.2a<a≤26.7, coordinates (x,y,z) in the ternary composition diagram are on, or on the left side of, a straight line AB that connects point A (0.0107a²-1.9142a+68.305, 0.0, -0.0107a²+0.9142a+31.695) and point B (0.0, 0.009a²-1.6045a+59.318, -0.009a²+0.6045a+40.682);

[0445] if 26.7<a≤36.7, coordinates (x,y,z) in the ternary composition diagram are on, or on the left side of, a straight line AB that connects point A (0.0103a²-1.9225a+68.793,

0.0, -0.0103a²+0.9225a+31.207) and point B (0.0, 0.0046a²-1.41a+57.286, -0.0046a²+0.41a+42.714); and

[0446] if 36.7<a≤46.7, coordinates (x,y,z) in the ternary composition diagram are on, or on the left side of, a straight line AB that connects point A (0.0085a²-1.8102a+67.1, 0.0, -0.0085a²+0.8102a+32.9) and point B (0.0, 0.0012a²-1.1659a+52.95, -0.0012a²+0.1659a+47.05).

[0447] Actual points having a refrigerating capacity ratio of 85% or more form a curved line that connects point A and point B in FIG. 3, and that extends toward the 1234yf side. Accordingly, when coordinates are on, or on the left side of, the straight line AB, the refrigerating capacity ratio relative to R410A is 85% or more.

[0448] Similarly, it was also found that in the ternary composition diagram, if 0<a≤11.1, when coordinates (x,y,z) are on, or on the left side of, a straight line D'C that connects point D' (0.0, 0.0224a²+0.968a+75.4, -0.0224a²-1.968a+24.6) and point C (-0.2304a²-0.4062a+32.9, 0.2304a²-0.5938a+67.1, 0.0); or if 11.1<a≤46.7, when coordinates are in the entire region, the COP ratio relative to that of R410A is 92.5% or more.

[0449] In FIG. 3, the COP ratio of 92.5% or more forms a curved line CD. In FIG. 3, an approximate line formed by connecting three points: point C (32.9, 67.1, 0.0) and points (26.6, 68.4, 5) (19.5, 70.5, 10) where the COP ratio is 92.5% when the concentration of R1234yf is 5 mass % and 10 mass % was obtained, and a straight line that connects point C and point D' (0, 75.4, 24.6), which is the intersection of the approximate line and a point where the concentration of HFO-1132(E) is 0.0 mass % was defined as a line segment D'C. In FIG. 4, point D'(0, 83.4, 9.5) was similarly obtained from an approximate curve formed by connecting point C (18.4, 74.5, 0) and points (13.9, 76.5, 2.5) (8.7, 79.2, 5) where the COP ratio is 92.5%, and a straight line that connects point C and point D' was defined as the straight line D'C.

[0450] The composition of each mixture was defined as WCF. A leak simulation was performed using NIST Stan-

Standard Reference Database REFLEAK Version 4.0 under the conditions of Equipment, Storage, Shipping, Leak, and Recharge according to the ASHRAE Standard 34-2013. The most flammable fraction was defined as WCF.

[0451] For the flammability, the burning velocity was measured according to the ANSI/ASHRAE Standard 34-2013. Both WCF and WCFE having a burning velocity of 10 cm/s or less were determined to be classified as “Class 2L (lower flammability).”

[0452] A burning velocity test was performed using the apparatus shown in FIG. 1 in the following manner. First, the mixed refrigerants used had a purity of 99.5% or more, and were degassed by repeating a cycle of freezing, pumping, and thawing until no traces of air were observed on the

vacuum gauge. The burning velocity was measured by the closed method. The initial temperature was ambient temperature. Ignition was performed by generating an electric spark between the electrodes in the center of a sample cell. The duration of the discharge was 1.0 to 9.9 ms, and the ignition energy was typically about 0.1 to 1.0 J. The spread of the flame was visualized using schlieren photographs. A cylindrical container (inner diameter: 155 mm, length: 198 mm) equipped with two light transmission acrylic windows was used as the sample cell, and a xenon lamp was used as the light source. Schlieren images of the flame were recorded by a high-speed digital video camera at a frame rate of 600 fps and stored on a PC.

[0453] The results are shown in Tables 97 to 104.

TABLE 97

Item			Comp. Ex. 6	Comp. Ex. 13	Comp. Ex. 19	Comp. Ex. 24	Comp. Ex. 29	Comp. Ex. 34
WCF	HFO-1132(E)	Mass %	72.0	60.9	55.8	52.1	48.6	45.4
	HFO-1123	Mass %	28.0	32.0	33.1	33.4	33.2	32.7
	R1234yf	Mass %	0.0	0.0	0.0	0	0	0
	R32	Mass %	0.0	7.1	11.1	14.5	18.2	21.9
Burning velocity (WCF)			cm/s	10	10	10	10	10

TABLE 98

Item			Comp. Ex. 39	Comp. Ex. 45	Comp. Ex. 51	Comp. Ex. 57	Comp. Ex. 62
WCF	HFO-1132(E)	Mass %	41.8	40	35.7	32	30.4
	HFO-1123	Mass %	31.5	30.7	23.6	23.9	21.8
	R1234yf	Mass %	0	0	0	0	0
	R32	Mass %	26.7	29.3	36.7	44.1	47.8
Burning velocity (WCF)			cm/s	10	10	10	10

TABLE 99

Item			Comp. Ex. 7	Comp. Ex. 14	Comp. Ex. 20	Comp. Ex. 25	Comp. Ex. 30	Comp. Ex. 35
WCF	HFO-1132(E)	Mass %	72.0	60.9	55.8	52.1	48.6	45.4
	HFO-1123	Mass %	0.0	0.0	0.0	0	0	0
	R1234yf	Mass %	28.0	32.0	33.1	33.4	33.2	32.7
	R32	Mass %	0.0	7.1	11.1	14.5	18.2	21.9
Burning velocity (WCF)			cm/s	10	10	10	10	10

TABLE 100

Item			Comp. Ex. 40	Comp. Ex. 46	Comp. Ex. 52	Comp. Ex. 58	Comp. Ex. 63
WCF	HFO-1132(E)	Mass %	41.8	40	35.7	32	30.4
	HFO-1123	Mass %	0	0	0	0	0
	R1234yf	Mass %	31.5	30.7	23.6	23.9	21.8
	R32	Mass %	26.7	29.3	36.7	44.1	47.8
Burning velocity (WCF)			cm/s	10	10	10	10

TABLE 101

Item			Comp. Ex. 8	Comp. Ex. 15	Comp. Ex. 21	Comp. Ex. 26	Comp. Ex. 31	Comp. Ex. 36
WCF	HFO-1132(E)	Mass %	47.1	40.5	37.0	34.3	32.0	30.3
	HFO-1123	Mass %	52.9	52.4	51.9	51.2	49.8	47.8

TABLE 101-continued

Item			Comp. Ex. 8	Comp. Ex. 15	Comp. Ex. 21	Comp. Ex. 26	Comp. Ex. 31	Comp. Ex. 36
	R1234yf	Mass %	0.0	0.0	0.0	0.0	0.0	0.0
	R32	Mass %	0.0	7.1	11.1	14.5	18.2	21.9
Leak condition that results in WCFF			Storage/ Shipping -40° C., 92% release, liquid phase side	Storage/ Shipping -40° C., 92% release, liquid phase side	Storage/ Shipping -40° C., 92% release, liquid phase side	Storage/ Shipping -40° C., 92% release, liquid phase side	Storage/ Shipping -40° C., 92% release, liquid phase side	Storage/ Shipping -40° C., 92% release, liquid phase side
WCFF	HFO-1132(E)	Mass %	72.0	62.4	56.2	50.6	45.1	40.0
	HFO-1123	Mass %	28.0	31.6	33.0	33.4	32.5	30.5
	R1234yf	Mass %	0.0	0.0	0.0	20.4	0.0	0.0
	R32	Mass %	0.0	50.9	10.8	16.0	22.4	29.5
Burning velocity (WCF)		cm/s	8 or less	8 or less	8 or less	8 or less	8 or less	8 or less
Burning velocity (WCFF)		cm/s	10	10	10	10	10	10

TABLE 102

Item			Comp. Ex. 41	Comp. Ex. 47	Comp. Ex. 53	Comp. Ex. 59	Comp. Ex. 64
WCF	HFO-1132(E)	Mass %	29.1	28.8	29.3	29.4	28.9
	HFO-1123	Mass %	44.2	41.9	34.0	26.5	23.3
	R1234yf	Mass %	0.0	0.0	0.0	0.0	0.0
	R32	Mass %	26.7	29.3	36.7	44.1	47.8
Leak condition that results in WCFF			Storage/ Shipping -40° C., 92% release, liquid phase side	Storage/ Shipping -40° C., 92% release, liquid phase side	Storage/ Shipping -40° C., 92% release, liquid phase side	Storage/ Shipping -40° C., 90% release, gas phase side	Storage/ Shipping -40° C., 86% release, gas phase side
WCFF	HFO-1132(E)	Mass %	34.6	32.2	27.7	28.3	27.5
	HFO-1123	Mass %	26.5	23.9	17.5	18.2	16.7
	R1234yf	Mass %	0.0	0.0	0.0	0.0	0.0
	R32	Mass %	38.9	43.9	54.8	53.5	55.8
Burning velocity (WCF)		cm/s	8 or less	8 or less	8.3	9.3	9.6
Burning velocity (WCFF)		cm/s	10	10	10	10	10

TABLE 103

Item			Comp. Ex. 9	Comp. Ex. 16	Comp. Ex. 22	Comp. Ex. 27	Comp. Ex. 32	Comp. Ex. 37
WCF	HFO-1132(E)	Mass %	61.7	47.0	41.0	36.5	32.5	28.8
	HFO-1123	Mass %	5.9	7.2	6.5	5.6	4.0	2.4
	R1234yf	Mass %	32.4	38.7	41.4	43.4	45.3	46.9
	R32	Mass %	0.0	7.1	11.1	14.5	18.2	21.9
Leak condition that results in WCFF			Storage/ Shipping -40° C., 0% release, gas phase side	Storage/ Shipping -40° C., 0% release, gas phase side	Storage/ Shipping -40° C., 0% release, gas phase side	Storage/ Shipping -40° C., 92% release, liquid phase side	Storage/ Shipping -40° C., 0% release, gas phase side	Storage/ Shipping -40° C., 0% release, gas phase side
WCFF	HFO-1132(E)	Mass %	72.0	56.2	50.4	46.0	42.4	39.1
	HFO-1123	Mass %	10.5	12.6	11.4	10.1	7.4	4.4
	R1234yf	Mass %	17.5	20.4	21.8	22.9	24.3	25.7
	R32	Mass %	0.0	10.8	16.3	21.0	25.9	30.8
Burning velocity (WCF)		cm/s	8 or less	8 or less	8 or less	8 or less	8 or less	8 or less
Burning velocity (WCFF)		cm/s	10	10	10	10	10	10

TABLE 104

Item			Comp. Ex. 42	Comp. Ex. 48	Comp. Ex. 54	Comp. Ex. 60	Comp. Ex. 65
WCF	HFO-1132(E)	Mass %	24.8	24.3	22.5	21.1	20.4
	HFO-1123	Mass %	0.0	0.0	0.0	0.0	0.0
	R1234yf	Mass %	48.5	46.4	40.8	34.8	31.8
	R32	Mass %	26.7	29.3	36.7	44.1	47.8

TABLE 104-continued

Item			Comp. Ex. 42	Comp. Ex. 48	Comp. Ex. 54	Comp. Ex. 60	Comp. Ex. 65
Leak condition that results in WCFF			Storage/ Shipping -40° C., 0% release, gas phase side	Storage/ Shipping -40° C., 0% release, gas phase side	Storage/ Shipping -40° C., 0% release, gas phase side	Storage/ Shipping -40° C., 0% release, gas phase side	Storage/ Shipping -40° C., 0% release, gas phase side
WCFF	HFO-1132(E)	Mass %	35.3	34.3	31.3	29.1	28.1
	HFO-1123	Mass %	0.0	0.0	0.0	0.0	0.0
	R1234yf	Mass %	27.4	26.2	23.1	19.8	18.2
	R32	Mass %	37.3	39.6	45.6	51.1	53.7
	Burning velocity (WCF)	cm/s	8 or less	8 or less	8 or less	8 or less	8 or less
	Burning velocity (WCFF)	cm/s	10	10	10	10	10

[0454] The results in Tables 97 to 100 indicate that the refrigerant has a WCF lower flammability in the following cases:

[0455] When the mass % of HFO-1132(E), HFO-1123, R1234yf, and R32 based on their sum in the mixed refrigerant of HFO-1132(E), HFO-1123, R1234yf, and R32 is respectively represented by x, y, z, and a, coordinates (x,y,z) in a ternary composition diagram in which the sum of HFO-1132(E), HFO-1123, and R1234yf is (100-a) mass % and a straight line connecting a point (0.0, 100.0-a, 0.0) and a point (0.0, 0.0, 100.0-a) is the base, if 0<a≤11.1, coordinates (x,y,z) in the ternary composition diagram are on or below a straight line GI that connects point G (0.026a²-1.7478a+72.0, -0.026a²+0.7478a+28.0, 0.0) and point I (0.026a²-1.7478a+72.0, 0.0, -0.026a²+0.7478a+28.0); if 11.1<a≤18.2, coordinates (x,y,z) in the ternary composition diagram are on or below a straight line GI that connects point G (0.02a²-1.6013a+71.105, -0.02a²+0.6013a+28.895, 0.0) and point I (0.02a²-1.6013a+71.105, 0.0, -0.02a²+0.6013a+28.895);

if 18.2<a≤26.7, coordinates (x,y,z) in the ternary composition diagram are on or below a straight line GI that connects point G (0.0135a²-1.4068a+69.727, -0.0135a²+0.4068a+30.273, 0.0) and point I (0.0135a²-1.4068a+69.727, 0.0, -0.0135a²+0.4068a+30.273); if 26.7<a≤36.7, coordinates (x,y,z) in the ternary composition diagram are on or below a straight line GI that connects point G (0.0111a²-1.3152a+68.986, -0.0111a²+0.3152a+31.014, 0.0) and point I (0.0111a²-1.3152a+68.986, 0.0, -0.0111a²+0.3152a+31.014); and if 36.7<a≤46.7, coordinates (x,y,z) in the ternary composition diagram are on or below a straight line GI that connects point G (0.0061a²-0.9918a+63.902, -0.0061a²-0.0082a+36.098,0.0) and point I (0.0061a²-0.9918a+63.902, 0.0, -0.0061a²-0.0082a+36.098).

[0456] Three points corresponding to point G (Table 105) and point I (Table 106) were individually obtained in each of the following five ranges by calculation, and their approximate expressions were obtained.

TABLE 105

Item	11.1 ≥ R32 ≥ 0			18.2 ≥ R32 ≥ 11.1			26.7 ≥ R32 ≥ 18.2		
R32	0	7.1	11.1	11.1	14.5	18.2	18.2	21.9	26.7
HFO-1132(E)	72.0	60.9	55.8	55.8	52.1	48.6	48.6	45.4	41.8
HFO-1123	28.0	32.0	33.1	33.1	33.4	33.2	33.2	32.7	31.5
R1234yf	0	0	0	0	0	0	0	0	0
R32	a			a			a		
HFO-1132(E)	0.026a ² - 1.7478a + 72.0			0.02a ² - 1.6013a + 71.105			0.0135a ² - 1.4068a + 69.727		
Approximate expression									
HFO-1123	-0.026a ² + 0.7478a + 28.0			-0.02a ² + 0.6013a + 28.895			-0.0135a ² + 0.4068a + 30.273		
Approximate expression									
R1234yf	0			0			0		
Approximate expression									
Item	36.7 ≥ R32 ≥ 26.7			46.7 ≥ R32 ≥ 36.7					
R32	26.7	29.3	36.7	36.7	44.1	47.8			
HFO-1132(E)	41.8	40.0	35.7	35.7	32.0	30.4			
HFO-1123	31.5	30.7	27.6	27.6	23.9	21.8			
R1234yf	0	0	0	0	0	0			
R32	a			a					
HFO-1132(E)	0.0111a ² - 1.3152a + 68.986			0.0061a ² - 0.9918a + 63.902					
Approximate expression									
HFO-1123	-0.0111a ² + 0.3152a + 31.014			-0.0061a ² - 0.0082a + 36.098					
Approximate expression									
R1234yf	0			0					
Approximate expression									

TABLE 106

Item	11.1 ≥ R32 > 0			18.2 ≥ R32 ≥ 11.1			26.7 ≥ R32 ≥ 18.2		
R32	0	7.1	11.1	11.1	14.5	18.2	18.2	21.9	26.7
HFO-1132(E)	72.0	60.9	55.8	55.8	52.1	48.6	48.6	45.4	41.8
HFO-1123	0	0	0	0	0	0	0	0	0
R1234yf	28.0	32.0	33.1	33.1	33.4	33.2	33.2	32.7	31.5
R32	a			a			a		
HFO-1132(E)	0.026a ² - 1.7478a + 72.0			0.02a ² - 1.6013a + 71.105			0.0135a ² - 1.4068a + 69.727		
Approximate expression									
HFO-1123	0			0			0		
Approximate expression									
R1234yf	-0.026a ² + 0.7478a + 28.0			-0.02a ² + 0.6013a + 28.895			-0.0135a ² + 0.4068a + 30.273		
Approximate expression									

Item	36.7 ≥ R32 ≥ 26.7			46.7 ≥ R32 ≥ 36.7		
R32	26.7	29.3	36.7	36.7	44.1	47.8
HFO-1132(E)	41.8	40.0	35.7	35.7	32.0	30.4
HFO-1123	0	0	0	0	0	0
R1234yf	31.5	30.7	23.6	23.6	23.5	21.8
R32	x			x		
HFO-1132(E)	0.0111a ² - 1.3152a + 68.986			0.0061a ² - 0.9918a + 63.902		
Approximate expression						
HFO-1123	0			0		
Approximate expression						
R1234yf	-0.0111a ² + 0.3152a + 31.014			-0.0061a ² - 0.0082a + 36.098		
Approximate expression						

[0457] The results in Tables 101 to 104 indicate that the refrigerant is determined to have a WCFE lower flammability, and the flammability classification according to the ASHRAE Standard is “2L (flammability)” in the following cases:

[0458] When the mass % of HFO-1132(E), HFO-1123, R1234yf, and R32 based on their sum in the mixed refrigerant of HFO-1132(E), HFO-1123, R1234yf, and R32 is respectively represented by x, y, z, and a, in a ternary composition diagram in which the sum of HFO-1132(E), HFO-1123, and R1234yf is (100-a) mass % and a straight line connecting a point (0.0, 100.0-a, 0.0) and a point (0.0, 0.0, 100.0-a) is the base, if 0<a≤11.1, coordinates (x,y,z) in the ternary composition diagram are on or below a straight line JK' that connects point J (0.0049a²-0.9645a+47.1, -0.0049a²-0.0355a+52.9, 0.0) and point K'(0.0514a²-2.4353a+61.7, -0.0323a²+0.4122a+5.9, -0.0191a²+1.0231a+32.4); if 11.1<a≤18.2, coordinates are on a straight line JK' that connects point J (0.0243a²-1.4161a+49.725, -0.0243a²+0.4161a+50.275, 0.0) and point K'(0.0341a²-2.1977a+61.187, -0.0236a²+0.34a+5.636, -0.0105a²+0.

8577a+33.177); if 18.2<a≤26.7, coordinates are on or below a straight line JK' that connects point J (0.0246a²-1.4476a+50.184, -0.0246a²+0.4476a+49.816, 0.0) and point K' (0.0196a²-1.7863a+58.515, -0.0079a²-0.1136a+8.702, -0.0117a²+0.8999a+32.783); if 26.7<a≤36.7, coordinates are on or below a straight line JK' that connects point J (0.0183a²-1.1399a+46.493, -0.0183a²+0.1399a+53.507, 0.0) and point K' (-0.0051a²+0.0929a+25.95, 0.0, 0.0051a²-1.0929a+74.05); and if 36.7<a≤46.7, coordinates are on or below a straight line JK' that connects point J (-0.0134a²+1.0956a+7.13, 0.0134a²-2.0956a+92.87, 0.0) and point K'(-1.892a+29.443, 0.0, 0.892a+70.557).

[0459] Actual points having a WCFE lower flammability form a curved line that connects point J and point K' (on the straight line AB) in FIG. 3 and extends toward the HFO-1132(E) side. Accordingly, when coordinates are on or below the straight line JK', WCFE lower flammability is achieved.

[0460] Three points corresponding to point J (Table 107) and point K' (Table 108) were individually obtained in each of the following five ranges by calculation, and their approximate expressions were obtained.

TABLE 107

Item	11.1 ≥ R32 > 0			18.2 ≥ R32 ≥ 11.1			26.7 ≥ R32 ≥ 18.2		
R32	0	7.1	11.1	11.1	14.5	18.2	18.2	21.9	26.7
HFO-1132(E)	47.1	40.5	37	37.0	34.3	32.0	32.0	30.3	29.1
HFO-1123	52.9	52.4	51.9	51.9	51.2	49.8	49.8	47.8	44.2
R1234yf	0	0	0	0	0	0	0	0	0
R32	a			a			a		
HFO-1132(E)	0.0049a ² - 0.9645a + 47.1			0.0243a ² - 1.4161a + 49.725			0.0246a ² - 1.4476a + 50.184		
Approximate expression									

TABLE 107-continued

HFO-1123 Approximate expression	$-0.0049a^2 - 0.0355a + 52.9$			$-0.0243a^2 + 0.4161a + 50.275$			$-0.0246a^2 + 0.4476a + 49.816$		
R1234yf Approximate expression	0			0			0		
Item	36.7 ≥ R32 ≥ 26.7						47.8 ≥ R32 ≥ 36.7		
R32	26.7	29.3	36.7	36.7	44.1	47.8			
HFO-1132(E)	29.1	28.8	29.3	29.3	29.4	28.9			
HFO-1123	44.2	41.9	34.0	34.0	26.5	23.3			
R1234yf	0	0	0	0	0	0			
R32	a						a		
HFO-1132(E) Approximate expression	$0.0183a^2 - 1.1399a + 46.493$						$-0.0134a^2 + 1.0956a + 7.13$		
HFO-1123 Approximate expression	$-0.0183a^2 + 0.1399a + 53.507$						$0.0134a^2 - 2.0956a + 92.87$		
R1234yf Approximate expression	0						0		

TABLE 108

Item	11.1 ≥ R32 > 0			18.2 ≥ R32 ≥ 11.1			26.7 ≥ R32 ≥ 18.2		
R32	0	7.1	11.1	11.1	14.5	18.2	18.2	21.9	26.7
HFO-1132(E)	61.7	47.0	41.0	41.0	36.5	32.5	32.5	28.8	24.8
HFO-1123	5.9	7.2	6.5	6.5	5.6	4.0	4.0	2.4	0
R1234yf	32.4	38.7	41.4	41.4	43.4	45.3	45.3	46.9	48.5
R32	x			x			x		
HFO-1132(E) Approximate expression	$0.0514a^2 - 2.4353a + 61.7$			$0.0341a^2 - 2.1977a + 61.187$			$0.0196a^2 - 1.7863a + 58.515$		
HFO-1123 Approximate expression	$-0.0323a^2 + 0.4122a + 5.9$			$-0.0236a^2 + 0.34a + 5.636$			$-0.0079a^2 - 0.1136a + 8.702$		
R1234yf Approximate expression	$-0.0191a^2 + 1.0231a + 32.4$			$-0.0105a^2 + 0.8577a + 33.177$			$-0.0117a^2 + 0.8999a + 32.783$		
Item	36.7 ≥ R32 ≥ 26.7						46.7 ≥ R32 ≥ 36.7		
R32	26.7	29.3	36.7	36.7	44.1	47.8			
HFO-1132(E)	24.8	24.3	22.5	22.5	21.1	20.4			
HFO-1123	0	0	0	0	0	0			
R1234yf	48.5	46.4	40.8	40.8	34.8	31.8			
R32	x						x		
HFO-1132(E) Approximate expression	$-0.0051a^2 + 0.0929a + 25.95$						$-1.892a + 29.443$		
HFO-1123 Approximate expression	0						0		
R1234yf Approximate expression	$0.0051a^2 - 1.0929a + 74.05$						$0.892a + 70.557$		

[0461] FIGS. 3 to 13 show compositions whose R32 content a (mass %) is 0 mass %, 7.1 mass %, 11.1 mass %, 14.5 mass %, 18.2 mass %, 21.9 mass %, 26.7 mass %, 29.3 mass %, 36.7 mass %, 44.1 mass %, and 47.8 mass %, respectively.

[0462] Points A, B, C, and D' were obtained in the following manner according to approximate calculation.

[0463] Point A is a point where the content of HFO-1123 is 0 mass %, and a refrigerating capacity ratio of 85% relative to that of R410A is achieved. Three points corresponding to point A were obtained in each of the following five ranges by calculation, and their approximate expressions were obtained (Table 109).

TABLE 109

Item	11.1 ≥ R32 > 0			18.2 ≥ R32 ≥ 11.1			26.7 ≥ R32 ≥ 18.2		
R32	0	7.1	11.1	11.1	14.5	18.2	18.2	21.9	26.7
HFO-1132(E)	68.6	55.3	48.4	48.4	42.8	37	37	31.5	24.8
HFO-1123	0	0	0	0	0	0	0	0	0
R1234yf	31.4	37.6	40.5	40.5	42.7	44.8	44.8	46.6	48.5
R32	a			a			a		
HFO-1132(E)	0.0134a ² - 1.9681a + 68.6			0.0112a ² - 1.9337a + 68.484			0.0107a ² - 1.9142a + 68.305		
Approximate expression									
HFO-1123	0			0			0		
Approximate expression									
R1234yf	-0.0134a ² + 0.9681a + 31.4			-0.0112a ² + 0.9337a + 31.516			-0.0107a ² + 0.9142a + 31.695		
Approximate expression									

Item	36.7 ≥ R32 ≥ 26.7			46.7 ≥ R32 ≥ 36.7		
R32	26.7	29.3	36.7	36.7	44.1	47.8
HFO-1132(E)	24.8	21.3	12.1	12.1	3.8	0
HFO-1123	0	0	0	0	0	0
R1234yf	48.5	49.4	51.2	51.2	52.1	52.2
R32	a			a		
HFO-1132(E)	0.0103a ² - 1.9225a + 68.793			0.0085a ² - 1.8102a + 67.1		
Approximate expression						
HFO-1123	0			0		
Approximate expression						
R1234yf	-0.0103a ² + 0.9225a + 31.207			-0.0085a ² + 0.8102a + 32.9		
Approximate expression						

[0464] Point B is a point where the content of HFO-1132 (E) is 0 mass %, and a refrigerating capacity ratio of 85% relative to that of R410A is achieved.

[0465] Three points corresponding to point B were obtained in each of the following five ranges by calculation, and their approximate expressions were obtained (Table 110).

TABLE 110

Item	11.1 ≥ R32 > 0			18.2 ≥ R32 ≥ 11.1			26.7 ≥ R32 ≥ 18.2		
R32	0	7.1	11.1	11.1	14.5	18.2	18.2	21.9	26.7
HFO-1132(E)	0	0	0	0	0	0	0	0	0
HFO-1123	58.7	47.8	42.3	42.3	37.8	33.1	33.1	28.5	22.9
R1234yf	41.3	45.1	46.6	46.6	47.7	48.7	48.7	49.6	50.4
R32	a			a			a		
HFO-1132(E)	0			0			0		
Approximate expression									
HFO-1123	0.0144a ² - 1.6377a + 58.7			0.0075a ² - 1.5156a + 58.199			0.009a ² - 1.6045a + 59.318		
Approximate expression									
R1234yf	-0.0144a ² + 0.6377a + 41.3			-0.0075a ² + 0.5156a + 41.801			-0.009a ² + 0.6045a + 40.682		
Approximate expression									

Item	36.7 ≥ R32 ≥ 26.7			46.7 ≥ R32 ≥ 36.7		
R32	26.7	29.3	36.7	36.7	44.1	47.8
HFO-1132(E)	0	0	0	0	0	0
HFO-1123	22.9	19.9	11.7	11.8	3.9	0
R1234yf	50.4	50.8	51.6	51.5	52.0	52.2
R32	a			a		
HFO-1132(E)	0			0		
Approximate expression						
HFO-1123	0.0046a ² - 1.41a + 57.286			0.0012a ² - 1.1659a + 52.95		
Approximate expression						

TABLE 110-continued

R1234yf Approximate expression	$-0.0046a^2 + 0.41a + 42.714$	$-0.0012a^2 + 0.1659a + 47.05$
--------------------------------------	-------------------------------	--------------------------------

[0466] Point D' is a point where the content of HFO-1132 (E) is 0 mass %, and a COP ratio of 95.5% relative to that of R410A is achieved.

[0467] Three points corresponding to point D' were obtained in each of the following by calculation, and their approximate expressions were obtained (Table 111).

TABLE 111

Item	11.1 ≥ R32 > 0		
R32	0	7.1	11.1
HFO-1132(E)	0	0	0
HFO-1123	75.4	83.4	88.9
R1234yf	24.6	9.5	0
R32		a	
HFO-1132(E)		0	
Approximate expression			
HFO-1123	$0.0224a^2 + 0.968a + 75.4$		
Approximate expression			
R1234yf	$-0.0224a^2 - 1.968a + 24.6$		
Approximate expression			

[0468] Point C is a point where the content of R1234yf is 0 mass %, and a COP ratio of 95.5% relative to that of R410A is achieved.

[0469] Three points corresponding to point C were obtained in each of the following by calculation, and their approximate expressions were obtained (Table 112).

TABLE 112

Item	11.1 ≥ R32 > 0		
R32	0	7.1	11.1
HFO-1132(E)	32.9	18.4	0
HFO-1123	67.1	74.5	88.9
R1234yf	0	0	0
R32		a	
HFO-1132(E)	$-0.2304a^2 - 0.4062a + 32.9$		
Approximate expression			
HFO-1123	$0.2304a^2 - 0.5938a + 67.1$		
Approximate expression			
R1234yf	0		
Approximate expression			

(5-4) Refrigerant D

[0470] The refrigerant D according to the present disclosure is a mixed refrigerant comprising trans-1,2-difluoroethylene (HFO-1132(E)), difluoromethane (R32), and 2,3,3,3-tetrafluoro-1-propene (R1234yf).

[0471] The refrigerant D according to the present disclosure has various properties that are desirable as an R410A-alternative refrigerant; i.e., a refrigerating capacity equivalent

to that of R410A, a sufficiently low GWP, and a lower flammability (Class 2L) according to the ASHRAE standard.

[0472] The refrigerant D according to the present disclosure is preferably a refrigerant wherein

[0473] when the mass % of HFO-1132(E), R32, and R1234yf based on their sum is respectively represented by x, y, and z, coordinates (x,y,z) in a ternary composition diagram in which the sum of HFO-1132(E), R32, and R1234yf is 100 mass % are within the range of a figure surrounded by line segments IJ, JN, NE, and EI that connect the following 4 points:

- point I (72.0, 0.0, 28.0),
- point J (48.5, 18.3, 33.2),
- point N (27.7, 18.2, 54.1), and
- point E (58.3, 0.0, 41.7),

or on these line segments (excluding the points on the line segment EI);

[0474] the line segment IJ is represented by coordinates $(0.0236y^2 - 1.7616y + 72.0, y, -0.0236y^2 + 0.7616y + 28.0)$;

[0475] the line segment NE is represented by coordinates $(0.012y^2 - 1.9003y + 58.3, y, -0.012y^2 + 0.9003y + 41.7)$; and

[0476] the line segments JN and EI are straight lines. When the requirements above are satisfied, the refrigerant according to the present disclosure has a refrigerating capacity ratio of 80% or more relative to R410A, a GWP of 125 or less, and a WCF lower flammability.

[0477] The refrigerant D according to the present disclosure is preferably a refrigerant wherein

[0478] when the mass % of HFO-1132(E), R32, and R1234yf based on their sum is respectively represented by x, y, and z, coordinates (x,y,z) in a ternary composition diagram in which the sum of HFO-1132(E), R32, and R1234yf is 100 mass % are within the range of a figure surrounded by line segments MM', M'N, NV, VG, and GM that connect the following 5 points:

- point M (52.6, 0.0, 47.4),
- point M' (39.2, 5.0, 55.8),
- point N (27.7, 18.2, 54.1),
- point V (11.0, 18.1, 70.9), and
- point G (39.6, 0.0, 60.4),

or on these line segments (excluding the points on the line segment GM);

[0479] the line segment MM' is represented by coordinates $(0.132y^2 - 3.34y + 52.6, y, -0.132y^2 + 2.34y + 47.4)$;

[0480] the line segment M'N is represented by coordinates $(0.0596y^2 - 2.2541y + 48.98, y, -0.0596y^2 + 1.2541y + 51.02)$;

[0481] the line segment VG is represented by coordinates $(0.0123y^2 - 1.8033y + 39.6, y, -0.0123y^2 + 0.8033y + 60.4)$; and

[0482] the line segments NV and GM are straight lines. When the requirements above are satisfied, the refrigerant according to the present disclosure has a refrigerating capacity ratio of 70% or more relative to R410A, a GWP of 125 or less, and an ASHRAE lower flammability.

[0483] The refrigerant D according to the present disclosure is preferably a refrigerant wherein

[0484] when the mass % of HFO-1132(E), R32, and R1234yf based on their sum is respectively represented by x, y, and z, coordinates (x,y,z) in a ternary composition diagram in which the sum of HFO-1132(E), R32, and

R1234yf is 100 mass % are within the range of a figure surrounded by line segments ON, NU, and UO that connect the following 3 points:

point O (22.6, 36.8, 40.6),

point N (27.7, 18.2, 54.1), and

point U (3.9, 36.7, 59.4),

or on these line segments;

[0485] the line segment ON is represented by coordinates $(0.0072y^2 - 0.6701y + 37.512, y, -0.0072y^2 - 0.3299y + 62.488)$;

[0486] the line segment NU is represented by coordinates $(0.0083y^2 - 1.7403y + 56.635, y, -0.0083y^2 + 0.7403y + 43.365)$; and

[0487] the line segment UO is a straight line. When the requirements above are satisfied, the refrigerant according to the present disclosure has a refrigerating capacity ratio of 80% or more relative to R410A, a GWP of 250 or less, and an ASHRAE lower flammability.

[0488] The refrigerant D according to the present disclosure is preferably a refrigerant wherein

[0489] when the mass % of HFO-1132(E), R32, and R1234yf based on their sum is respectively represented by x, y, and z, coordinates (x,y,z) in a ternary composition diagram in which the sum of HFO-1132(E), R32, and R1234yf is 100 mass % are within the range of a figure surrounded by line segments QR, RT, TL, LK, and KQ that connect the following 5 points:

point Q (44.6, 23.0, 32.4),

point R (25.5, 36.8, 37.7),

point T (8.6, 51.6, 39.8),

point L (28.9, 51.7, 19.4), and

point K (35.6, 36.8, 27.6),

or on these line segments;

[0490] the line segment QR is represented by coordinates $(0.0099y^2 - 1.975y + 84.765, y, -0.0099y^2 + 0.975y + 15.235)$;

[0491] the line segment RT is represented by coordinates $(0.0082y^2 - 1.8683y + 83.126, y, -0.0082y^2 + 0.8683y + 16.874)$;

[0492] the line segment LK is represented by coordinates $(0.0049y^2 - 0.8842y + 61.488, y, -0.0049y^2 - 0.1158y + 38.512)$;

[0493] the line segment KQ is represented by coordinates $(0.0095y^2 - 1.2222y + 67.676, y, -0.0095y^2 + 0.2222y + 32.324)$; and

[0494] the line segment TL is a straight line. When the requirements above are satisfied, the refrigerant according to the present disclosure has a refrigerating capacity ratio of 92.5% or more relative to R410A, a GWP of 350 or less, and a WCF lower flammability.

[0495] The refrigerant D according to the present disclosure is preferably a refrigerant wherein

[0496] when the mass % of HFO-1132(E), R32, and R1234yf based on their sum is respectively represented by x, y, and z, coordinates (x,y,z) in a ternary composition diagram in which the sum of HFO-1132(E), R32, and R1234yf is 100 mass % are within the range of a figure surrounded by line segments PS, ST, and TP that connect the following 3 points:

point P (20.5, 51.7, 27.8),

point S (21.9, 39.7, 38.4), and

point T (8.6, 51.6, 39.8),

or on these line segments;

[0497] the line segment PS is represented by coordinates $(0.0064y^2 - 0.7103y + 40.1, y, -0.0064y^2 - 0.2897y + 59.9)$;

[0498] the line segment ST is represented by coordinates $(0.0082y^2 - 1.8683y + 83.126, y, -0.0082y^2 + 0.8683y + 16.874)$; and

[0499] the line segment TP is a straight line. When the requirements above are satisfied, the refrigerant according to the present disclosure has a refrigerating capacity ratio of 92.5% or more relative to R410A, a GWP of 350 or less, and an ASHRAE lower flammability.

[0500] The refrigerant D according to the present disclosure is preferably a refrigerant wherein

[0501] when the mass % of HFO-1132(E), R32, and R1234yf based on their sum is respectively represented by x, y, and z, coordinates (x,y,z) in a ternary composition diagram in which the sum of HFO-1132(E), R32, and R1234yf is 100 mass % are within the range of a figure surrounded by line segments ac, cf, fd, and da that connect the following 4 points:

point a (71.1, 0.0, 28.9),

point c (36.5, 18.2, 45.3),

point f (47.6, 18.3, 34.1), and

point d (72.0, 0.0, 28.0),

or on these line segments;

[0502] the line segment ac is represented by coordinates $(0.0181y^2 - 2.2288y + 71.096, y, -0.0181y^2 + 1.2288y + 28.904)$;

[0503] the line segment fd is represented by coordinates $(0.02y^2 - 1.7y + 72, y, -0.02y^2 + 0.7y + 28)$; and

[0504] the line segments cf and da are straight lines. When the requirements above are satisfied, the refrigerant according to the present disclosure has a refrigerating capacity ratio of 85% or more relative to R410A, a GWP of 125 or less, and a lower flammability (Class 2L) according to the ASHRAE standard.

[0505] The refrigerant D according to the present disclosure is preferably a refrigerant wherein

[0506] when the mass % of HFO-1132(E), R32, and R1234yf based on their sum is respectively represented by x, y, and z, coordinates (x,y,z) in a ternary composition diagram in which the sum of HFO-1132(E), R32, and R1234yf is 100 mass % are within the range of a figure surrounded by line segments ab, be, ed, and da that connect the following 4 points:

point a (71.1, 0.0, 28.9),

point b (42.6, 14.5, 42.9),

point e (51.4, 14.6, 34.0), and

point d (72.0, 0.0, 28.0),

or on these line segments;

[0507] the line segment ab is represented by coordinates $(0.0181y^2 - 2.2288y + 71.096, y, -0.0181y^2 + 1.2288y + 28.904)$;

[0508] the line segment ed is represented by coordinates $(0.02y^2 - 1.7y + 72, y, -0.02y^2 + 0.7y + 28)$; and

[0509] the line segments be and da are straight lines. When the requirements above are satisfied, the refrigerant according to the present disclosure has a refrigerating capacity ratio of 85% or more relative to R410A, a GWP of 100 or less, and a lower flammability (Class 2L) according to the ASHRAE standard.

[0510] The refrigerant D according to the present disclosure is preferably a refrigerant wherein

[0511] when the mass % of HFO-1132(E), R32, and R1234yf based on their sum is respectively represented by x, y, and z, coordinates (x,y,z) in a ternary composition diagram in which the sum of HFO-1132(E), R32, and

TABLE 114-continued

Item	Unit	Comparative Example 14		Example 19		Example 21		Example 22
		M	Example 18	W	Example 20	N		
WCF	HFO-1132(E)	Mass %	72.0	57.8	48.7	43.6	40.6	34.9
	R32	Mass %	0.0	9.5	17.9	24.2	28.7	38.1
	R1234yf	Mass %	28.0	32.7	33.4	32.2	30.7	27.0
	Burning Velocity (WCF)	cm/s	8 or less	8 or less	8 or less	8 or less	8 or less	8 or less
	Burning Velocity (WCF)	cm/s	10	10	10	10	10	10

TABLE 115

Item	Unit	Example 23		Example 25	
		O	Example 24	P	
WCF	HFO-1132(E)	Mass %	22.6	21.2	20.5
	HFO-1123	Mass %	36.8	44.2	51.7
	R1234yf	Mass %	40.6	34.6	27.8
	Leak condition that results in WCF		Storage, Shipping, -40° C., 0% release, on the gas phase side	Storage, Shipping, -40° C., 0% release, on the gas phase side	Storage, Shipping, -40° C., 0% release, on the gas phase side
WCF	HFO-1132(E)	Mass %	31.4	29.2	27.1
	HFO-1123	Mass %	45.7	51.1	56.4
	R1234yf	Mass %	23.0	19.7	16.5
	Burning Velocity (WCF)	cm/s	8 or less	8 or less	8 or less
	Burning Velocity (WCF)	cm/s	10	10	10

[0523] The results indicate that under the condition that the mass % of HFO-1132(E), R32, and R1234yf based on their sum is respectively represented by x, y, and z, when coordinates (x,y,z) in the ternary composition diagram shown in FIG. 14 in which the sum of HFO-1132(E), R32, and R1234yf is 100 mass % are on the line segment that connects point I, point J, point K, and point L, or below these line segments, the refrigerant has a WCF lower flammability.

[0524] The results also indicate that when coordinates (x,y,z) in the ternary composition diagram shown in FIG. 14 are on the line segments that connect point M, point M', point W, point J, point N, and point P, or below these line segments, the refrigerant has an ASHRAE lower flammability.

[0525] Mixed refrigerants were prepared by mixing HFO-1132(E), R32, and

[0526] R1234yf in amounts (mass %) shown in Tables 116 to 144 based on the sum of HFO-1132(E), R32, and R1234yf. The coefficient of performance (COP) ratio and the refrigerating capacity ratio relative to R410 of the mixed refrigerants shown in Tables 116 to 144 were determined. The conditions for calculation were as described below.

[0527] Evaporating temperature: 5° C.

[0528] Condensation temperature: 45° C.

[0529] Degree of superheating: 5 K

[0530] Degree of subcooling: 5 K

[0531] Compressor efficiency: 70%

[0532] Tables 116 to 144 show these values together with the GWP of each mixed refrigerant.

TABLE 116

Item	Unit	Comparative		Comparative		Comparative		Comparative	
		Comparative Example 1	Example 2 A	Example 3 B	Example 4 A'	Example 5 B'	Example 6 A''	Example 7 B''	
HFO-1132(E)	Mass %	R410A	81.6	0.0	63.1	0.0	48.2	0.0	
R32	Mass %		18.4	18.1	36.9	36.7	51.8	51.5	
R1234yf	Mass %		0.0	81.9	0.0	63.3	0.0	48.5	
GWP	—	2088	125	125	250	250	350	350	
COP Ratio	%(relative to R410A)	100	98.7	103.6	98.7	102.3	99.2	102.2	
Refrigerating Capacity Ratio	%(relative to R410A)	100	105.3	62.5	109.9	77.5	112.1	87.3	

TABLE 117

Item	Unit	Comparative Example 8 C	Comparative Example 9	Comparative Example 10 C'	Example 1	Example 2 R	Example 3	Example 4 T
HFO-1132(E)	Mass %	85.5	66.1	52.1	37.8	25.5	16.6	8.6
R32	Mass %	0.0	10.0	18.2	27.6	36.8	44.2	51.6
R1234yf	Mass %	14.5	23.9	29.7	34.6	37.7	39.2	39.8
GWP	—	1	69	125	188	250	300	350
COP Ratio	% (relative to R410A)	99.8	99.3	99.3	99.6	100.2	100.8	101.4
Refrigerating Capacity Ratio	% (relative to R410A)	92.5	92.5	92.5	92.5	92.5	92.5	92.5

TABLE 118

Item	Unit	Comparative Example 11 E	Example 5	Example 6 N	Example 7	Example 8 U	Comparative Example 12 G	Example 9	Example 10 V
HFO-1132(E)	Mass %	58.3	40.5	27.7	14.9	3.9	39.6	22.8	11.0
R32	Mass %	0.0	10.0	18.2	27.6	36.7	0.0	10.0	18.1
R1234yf	Mass %	41.7	49.5	54.1	57.5	59.4	60.4	67.2	70.9
GWP	—	2	70	125	189	250	3	70	125
COP Ratio	%(relative to R410A)	100.3	100.3	100.7	101.2	101.9	101.4	101.8	102.3
Refrigerating Capacity Ratio	%(relative to R410A)	80.0	80.0	80.0	80.0	80.0	70.0	70.0	70.0

TABLE 119

Item	Unit	Comparative Example 13 I	Example 11	Example 12 J	Example 13	Example 14 K	Example 15	Example 16 L	Example 17 Q
HFO-1132(E)	Mass %	72.0	57.2	48.5	41.2	35.6	32.0	28.9	44.6
R32	Mass %	0.0	10.0	18.3	27.6	36.8	44.2	51.7	23.0
R1234yf	Mass %	28.0	32.8	33.2	31.2	27.6	23.8	19.4	32.4
GWP	—	2	69	125	188	250	300	350	157
COP Ratio	%(relative to R410A)	99.9	99.5	99.4	99.5	99.6	99.8	100.1	99.4
Refrigerating Capacity Ratio	%(relative to R410A)	86.6	88.4	90.9	94.2	97.7	100.5	103.3	92.5

TABLE 120

Item	Unit	Comparative Example 14 M	Example 18	Example 19 W	Example 20	Example 21 N	Example 22
HFO-1132(E)	Mass %	52.6	39.2	32.4	29.3	27.7	24.5
R32	Mass %	0.0	5.0	10.0	14.5	18.2	27.6
R1234yf	Mass %	47.4	55.8	57.6	56.2	54.1	47.9
GWP	—	2	36	70	100	125	188
COP Ratio	%(relative to R410A)	100.5	100.9	100.9	100.8	100.7	100.4
Refrigerating Capacity Ratio	%(relative to R410A)	77.1	74.8	75.6	77.8	80.0	85.5

TABLE 121

Item	Unit	Example 23 O	Example 24	Example 25 P	Example 26 S
HFO-1132(E)	Mass %	22.6	21.2	20.5	21.9
R32	Mass %	36.8	44.2	51.7	39.7
R1234yf	Mass %	40.6	34.6	27.8	38.4
GWP	—	250	300	350	270

TABLE 121-continued

Item	Unit	Example 23 O	Example 24	Example 25 P	Example 26 S
COP Ratio	%(relative to R410A)	100.4	100.5	100.6	100.4
Refrigerating Capacity Ratio	%(relative to R410A)	91.0	95.0	99.1	92.5

TABLE 122

Item	Unit	Comparative Example 15	Comparative Example 16	Comparative Example 17	Comparative Example 18	Example 27	Example 28	Comparative Example 19	Comparative Example 20
HFO-1132(E)	Mass %	10.0	20.0	30.0	40.0	50.0	60.0	70.0	80.0
R32	Mass %	5.0	5.0	5.0	5.0	5.0	5.0	5.0	5.0
R1234yf	Mass %	85.0	75.0	65.0	55.0	45.0	35.0	25.0	15.0
GWP	—	37	37	37	36	36	36	35	35
COP Ratio	%(relative to R410A)	103.4	102.6	101.6	100.8	100.2	99.8	99.6	99.4
Refrigerating Capacity Ratio	%(relative to R410A)	56.4	63.3	69.5	75.2	80.5	85.4	90.1	94.4

TABLE 123

Item	Unit	Comparative Example 21	Comparative Example 22	Example 29	Comparative Example 23	Example 30	Comparative Example 24	Comparative Example 25	Comparative Example 26
HFO-1132(E)	Mass %	10.0	20.0	30.0	40.0	50.0	60.0	70.0	80.0
R32	Mass %	10.0	10.0	10.0	10.0	10.0	10.0	10.0	10.0
R1234yf	Mass %	80.0	70.0	60.0	50.0	40.0	30.0	20.0	10.0
GWP	—	71	71	70	70	70	69	69	69
COP Ratio	%(relative to R410A)	103.1	102.1	101.1	100.4	99.8	99.5	99.2	99.1
Refrigerating Capacity Ratio	%(relative to R410A)	61.8	68.3	74.3	79.7	84.9	89.7	94.2	98.4

TABLE 124

Item	Unit	Comparative Example 27	Example 31	Comparative Example 28	Example 32	Example 33	Comparative Example 29	Comparative Example 30	Comparative Example 31
HFO-1132(E)	Mass %	10.0	20.0	30.0	40.0	50.0	60.0	70.0	80.0
R32	Mass %	15.0	15.0	15.0	15.0	15.0	15.0	15.0	15.0
R1234yf	Mass %	75.0	65.0	55.0	45.0	35.0	25.0	15.0	5.0
GWP	—	104	104	104	103	103	103	103	102
COP Ratio	%(relative to R410A)	102.7	101.6	100.7	100.0	99.5	99.2	99.0	98.9
Refrigerating Capacity Ratio	%(relative to R410A)	66.6	72.9	78.6	84.0	89.0	93.7	98.1	102.2

TABLE 125

Item	Unit	Comparative Example 32	Comparative Example 33	Comparative Example 34	Comparative Example 35	Comparative Example 36	Comparative Example 37	Comparative Example 38	Comparative Example 39
HFO-1132(E)	Mass %	10.0	20.0	30.0	40.0	50.0	60.0	70.0	10.0
R32	Mass %	20.0	20.0	20.0	20.0	20.0	20.0	20.0	25.0
R1234yf	Mass %	70.0	60.0	50.0	40.0	30.0	20.0	10.0	65.0
GWP	—	138	138	137	137	137	136	136	171
COP Ratio	%(relative to R410A)	102.3	101.2	100.4	99.7	99.3	99.0	98.8	101.9
Refrigerating Capacity Ratio	%(relative to R410A)	71.0	77.1	82.7	88.0	92.9	97.5	101.7	75.0

TABLE 126

Item	Unit	Example 34	Comparative Example 40	Comparative Example 41	Comparative Example 42	Comparative Example 43	Comparative Example 44	Comparative Example 45	Example 35
HFO-1132(E)	Mass %	20.0	30.0	40.0	50.0	60.0	70.0	10.0	20.0
R32	Mass %	25.0	25.0	25.0	25.0	25.0	25.0	30.0	30.0
R1234yf	Mass %	55.0	45.0	35.0	25.0	15.0	5.0	60.0	50.0
GWP	—	171	171	171	170	170	170	205	205
COP Ratio	%(relative to R410A)	100.9	100.1	99.6	99.2	98.9	98.7	101.6	100.7
Refrigerating Capacity Ratio	%(relative to R410A)	81.0	86.6	91.7	96.5	101.0	105.2	78.9	84.8

TABLE 127

Item	Unit	Comparative Example 46	Comparative Example 47	Comparative Example 48	Comparative Example 49	Example 36	Example 37	Example 38	Comparative Example 50
HFO-1132(E)	Mass %	30.0	40.0	50.0	60.0	10.0	20.0	30.0	40.0
R32	Mass %	30.0	30.0	30.0	30.0	35.0	35.0	35.0	35.0
R1234yf	Mass %	40.0	30.0	20.0	10.0	55.0	45.0	35.0	25.0
GWP	—	204	204	204	204	239	238	238	238
COP Ratio	%(relative to R410A)	100.0	99.5	99.1	98.8	101.4	100.6	99.9	99.4
Refrigerating Capacity Ratio	%(relative to R410A)	90.2	95.3	100.0	104.4	82.5	88.3	93.7	98.6

TABLE 128

Item	Unit	Comparative Example 51	Comparative Example 52	Comparative Example 53	Comparative Example 54	Example 39	Comparative Example 55	Comparative Example 56	Comparative Example 57
HFO-1132(E)	Mass %	50.0	60.0	10.0	20.0	30.0	40.0	50.0	10.0
R32	Mass %	35.0	35.0	40.0	40.0	40.0	40.0	40.0	45.0
R1234yf	Mass %	15.0	5.0	50.0	40.0	30.0	20.0	10.0	45.0
GWP	—	237	237	272	272	272	271	271	306
COP Ratio	%(relative to R410A)	99.0	98.8	101.3	100.6	99.9	99.4	99.0	101.3
Refrigerating Capacity Ratio	%(relative to R410A)	103.2	107.5	86.0	91.7	96.9	101.8	106.3	89.3

TABLE 129

Item	Unit	Example 40	Example 41	Comparative Example 58	Comparative Example 59	Comparative Example 60	Example 42	Comparative Example 61	Comparative Example 62
HFO-1132(E)	Mass %	20.0	30.0	40.0	50.0	10.0	20.0	30.0	40.0
R32	Mass %	45.0	45.0	45.0	45.0	50.0	50.0	50.0	50.0
R1234yf	Mass %	35.0	25.0	15.0	5.0	40.0	30.0	20.0	10.0
GWP	—	305	305	305	304	339	339	339	338
COP Ratio	%(relative to R410A)	100.6	100.0	99.5	99.1	101.3	100.6	100.0	99.5
Refrigerating Capacity Ratio	%(relative to R410A)	94.9	100.0	104.7	109.2	92.4	97.8	102.9	107.5

TABLE 130

Item	Unit	Comparative Example 63	Comparative Example 64	Comparative Example 65	Comparative Example 66	Example 43	Example 44	Example 45	Example 46
HFO-1132(E)	Mass %	10.0	20.0	30.0	40.0	56.0	59.0	62.0	65.0
R32	Mass %	55.0	55.0	55.0	55.0	3.0	3.0	3.0	3.0
R1234yf	Mass %	35.0	25.0	15.0	5.0	41.0	38.0	35.0	32.0
GWP	—	373	372	372	372	22	22	22	22
COP Ratio	%(relative to R410A)	101.4	100.7	100.1	99.6	100.1	100.0	99.9	99.8
Refrigerating Capacity Ratio	%(relative to R410A)	95.3	100.6	105.6	110.2	81.7	83.2	84.6	86.0

TABLE 131

Item	Unit	Example 47	Example 48	Example 49	Example 50	Example 51	Example 52	Example 53	Example 54
HFO-1132(E)	Mass %	49.0	52.0	55.0	58.0	61.0	43.0	46.0	49.0
R32	Mass %	6.0	6.0	6.0	6.0	6.0	9.0	9.0	9.0
R1234yf	Mass %	45.0	42.0	39.0	36.0	33.0	48.0	45.0	42.0
GWP	—	43	43	43	43	42	63	63	63
COP Ratio	%(relative to R410A)	100.2	100.0	99.9	99.8	99.7	100.3	100.1	99.9
Refrigerating Capacity Ratio	%(relative to R410A)	80.9	82.4	83.9	85.4	86.8	80.4	82.0	83.5

TABLE 132

Item	Unit	Example 55	Example 56	Example 57	Example 58	Example 59	Example 60	Example 61	Example 62
HFO-1132(E)	Mass %	52.0	55.0	58.0	38.0	41.0	44.0	47.0	50.0
R32	Mass %	9.0	9.0	9.0	12.0	12.0	12.0	12.0	12.0
R1234yf	Mass %	39.0	36.0	33.0	50.0	47.0	44.0	41.0	38.0
GWP	—	63	63	63	83	83	83	83	83
COP Ratio	%(relative to R410A)	99.8	99.7	99.6	100.3	100.1	100.0	99.8	99.7
Refrigerating Capacity Ratio	%(relative to R410A)	85.0	86.5	87.9	80.4	82.0	83.5	85.1	86.6

TABLE 133

Item	Unit	Example 63	Example 64	Example 65	Example 66	Example 67	Example 68	Example 69	Example 70
HFO-1132(E)	Mass %	53.0	33.0	36.0	39.0	42.0	45.0	48.0	51.0
R32	Mass %	12.0	15.0	15.0	15.0	15.0	15.0	15.0	15.0
R1234yf	Mass %	35.0	52.0	49.0	46.0	43.0	40.0	37.0	34.0
GWP	—	83	104	104	103	103	103	103	103
COP Ratio	%(relative to R410A)	99.6	100.5	100.3	100.1	99.9	99.7	99.6	99.5
Refrigerating Capacity Ratio	%(relative to R410A)	88.0	80.3	81.9	83.5	85.0	86.5	88.0	89.5

TABLE 134

Item	Unit	Example 71	Example 72	Example 73	Example 74	Example 75	Example 76	Example 77	Example 78
HFO-1132(E)	Mass %	29.0	32.0	35.0	38.0	41.0	44.0	47.0	36.0
R32	Mass %	18.0	18.0	18.0	18.0	18.0	18.0	18.0	3.0
R1234yf	Mass %	53.0	50.0	47.0	44.0	41.0	38.0	35.0	61.0
GWP	—	124	124	124	124	124	123	123	23
COP Ratio	%(relative to R410A)	100.6	100.3	100.1	99.9	99.8	99.6	99.5	101.3
Refrigerating Capacity Ratio	%(relative to R410A)	80.6	82.2	83.8	85.4	86.9	88.4	89.9	71.0

TABLE 135

Item	Unit	Example 79	Example 80	Example 81	Example 82	Example 83	Example 84	Example 85	Example 86
HFO-1132(E)	Mass %	39.0	42.0	30.0	33.0	36.0	26.0	29.0	32.0
R32	Mass %	3.0	3.0	6.0	6.0	6.0	9.0	9.0	9.0
R1234yf	Mass %	58.0	55.0	64.0	61.0	58.0	65.0	62.0	59.0
GWP	—	23	23	43	43	43	64	64	63
COP Ratio	%(relative to R410A)	101.1	100.9	101.5	101.3	101.0	101.6	101.3	101.1
Refrigerating Capacity Ratio	%(relative to R410A)	72.7	74.4	70.5	72.2	73.9	71.0	72.8	74.5

TABLE 136

Item	Unit	Example 87	Example 88	Example 89	Example 90	Example 91	Example 92	Example 93	Example 94
HFO-1132(E)	Mass %	21.0	24.0	27.0	30.0	16.0	19.0	22.0	25.0
R32	Mass %	12.0	12.0	12.0	12.0	15.0	15.0	15.0	15.0
R1234yf	Mass %	67.0	64.0	61.0	58.0	69.0	66.0	63.0	60.0
GWP	—	84	84	84	84	104	104	104	104
COP Ratio	%(relative to R410A)	101.8	101.5	101.2	101.0	102.1	101.8	101.4	101.2
Refrigerating Capacity Ratio	%(relative to R410A)	70.8	72.6	74.3	76.0	70.4	72.3	74.0	75.8

TABLE 137

Item	Unit	Example 95	Example 96	Example 97	Example 98	Example 99	Example 100	Example 101	Example 102
HFO-1132(E)	Mass %	28.0	12.0	15.0	18.0	21.0	24.0	27.0	25.0
R32	Mass %	15.0	18.0	18.0	18.0	18.0	18.0	18.0	21.0
R1234yf	Mass %	57.0	70.0	67.0	64.0	61.0	58.0	55.0	54.0
GWP	—	104	124	124	124	124	124	124	144
COP Ratio	%(relative to R410A)	100.9	102.2	101.9	101.6	101.3	101.0	100.7	100.7
Refrigerating Capacity Ratio	%(relative to R410A)	77.5	70.5	72.4	74.2	76.0	77.7	79.4	80.7

TABLE 138

Item	Unit	Example 103	Example 104	Example 105	Example 106	Example 107	Example 108	Example 109	Example 110
HFO-1132(E)	Mass %	21.0	24.0	17.0	20.0	23.0	13.0	16.0	19.0
R32	Mass %	24.0	24.0	27.0	27.0	27.0	30.0	30.0	30.0
R1234yf	Mass %	55.0	52.0	56.0	53.0	50.0	57.0	54.0	51.0
GWP	—	164	164	185	185	184	205	205	205
COP Ratio	%(relative to R410A)	100.9	100.6	101.1	100.8	100.6	101.3	101.0	100.8
Refrigerating Capacity Ratio	%(relative to R410A)	80.8	82.5	80.8	82.5	84.2	80.7	82.5	84.2

TABLE 139

Item	Unit	Example 111	Example 112	Example 113	Example 114	Example 115	Example 116	Example 117	Example 118
HFO-1132(E)	Mass %	22.0	9.0	12.0	15.0	18.0	21.0	8.0	12.0
R32	Mass %	30.0	33.0	33.0	33.0	33.0	33.0	36.0	36.0
R1234yf	Mass %	48.0	58.0	55.0	52.0	49.0	46.0	56.0	52.0
GWP	—	205	225	225	225	225	225	245	245
COP Ratio	%(relative to R410A)	100.5	101.6	101.3	101.0	100.8	100.5	101.6	101.2
Refrigerating Capacity Ratio	%(relative to R410A)	85.9	80.5	82.3	84.1	85.8	87.5	82.0	84.4

TABLE 140

Item	Unit	Example 119	Example 120	Example 121	Example 122	Example 123	Example 124	Example 125	Example 126
HFO-1132(E)	Mass %	15.0	18.0	21.0	42.0	39.0	34.0	37.0	30.0
R32	Mass %	36.0	36.0	36.0	25.0	28.0	31.0	31.0	34.0
R1234yf	Mass %	49.0	46.0	43.0	33.0	33.0	35.0	32.0	36.0
GWP	—	245	245	245	170	191	211	211	231
COP Ratio	%(relative to R410A)	101.0	100.7	100.5	99.5	99.5	99.8	99.6	99.9
Refrigerating Capacity Ratio	%(relative to R410A)	86.2	87.9	89.6	92.7	93.4	93.0	94.5	93.0

TABLE 141

Item	Unit	Exam- ple 127	Exam- ple 128	Exam- ple 129	Exam- ple 130	Exam- ple 131	Exam- ple 132	Exam- ple 133	Exam- ple 134
HFO-1132(E)	Mass %	33.0	36.0	24.0	27.0	30.0	33.0	23.0	26.0
R32	Mass %	34.0	34.0	37.0	37.0	37.0	37.0	40.0	40.0
R1234yf	Mass %	33.0	30.0	39.0	36.0	33.0	30.0	37.0	34.0
GWP	—	231	231	252	251	251	251	272	272
COP Ratio	% (relative to R410A)	99.8	99.6	100.3	100.1	99.9	99.8	100.4	100.2
Refrigerating Capacity Ratio	% (relative to R410A)	94.5	96.0	91.9	93.4	95.0	96.5	93.3	94.9

TABLE 142

Item	Unit	Exam- ple 135	Exam- ple 136	Exam- ple 137	Exam- ple 138	Exam- ple 139	Exam- ple 140	Exam- ple 141	Exam- ple 142
HFO-1132(E)	Mass %	29.0	32.0	19.0	22.0	25.0	28.0	31.0	18.0
R32	Mass %	40.0	40.0	43.0	43.0	43.0	43.0	43.0	46.0
R1234yf	Mass %	31.0	28.0	38.0	35.0	32.0	29.0	26.0	36.0
GWP	—	272	271	292	292	292	292	292	312
COP Ratio	%(relative to R410A)	100.0	99.8	100.6	100.4	100.2	100.1	99.9	100.7
Refrigerating Capacity Ratio	%(relative to R410A)	96.4	97.9	93.1	94.7	96.2	97.8	99.3	94.4

TABLE 143

Item	Unit	Exam- ple 143	Exam- ple 144	Exam- ple 145	Exam- ple 146	Exam- ple 147	Exam- ple 148	Exam- ple 149	Exam- ple 150
HFO-1132(E)	Mass %	21.0	23.0	26.0	29.0	13.0	16.0	19.0	22.0
R32	Mass %	46.0	46.0	46.0	46.0	49.0	49.0	49.0	49.0
R1234yf	Mass %	33.0	31.0	28.0	25.0	38.0	35.0	32.0	29.0
GWP	—	312	312	312	312	332	332	332	332
COP Ratio	% (relative to R410A)	100.5	100.4	100.2	100.0	101.1	100.9	100.7	100.5
Refrigerating Capacity Ratio	% (relative to R410A)	96.0	97.0	98.6	100.1	93.5	95.1	96.7	98.3

TABLE 144

Item	Unit	Example 151	Example 152
HFO-1132(E)	Mass %	25.0	28.0
R32	Mass %	49.0	49.0
R1234yf	Mass %	26.0	23.0
GWP	—	332	332
COP Ratio	%(relative to R410A)	100.3	100.1
Refrigerating Capacity Ratio	%(relative to R410A)	99.8	101.3

[0533] The results also indicate that under the condition that the mass % of HFO-1132(E), R32, and R1234yf based on their sum is respectively represented by x, y, and z, when coordinates (x,y,z) in a ternary composition diagram in which the sum of HFO-1132(E), R32, and R1234yf is 100 mass % are within the range of a figure surrounded by line segments IJ, JN, NE, and EI that connect the following 4 points:

- point I (72.0, 0.0, 28.0),
- point J (48.5, 18.3, 33.2),
- point N (27.7, 18.2, 54.1), and
- point E (58.3, 0.0, 41.7),

or on these line segments (excluding the points on the line segment EI),

[0534] the line segment IJ is represented by coordinates $(0.0236y^2 - 1.7616y + 72.0, y, -0.0236y^2 + 0.7616y + 28.0)$,

[0535] the line segment NE is represented by coordinates $(0.012y^2 - 1.9003y + 58.3, y, -0.012y^2 + 0.9003y + 41.7)$, and

[0536] the line segments JN and EI are straight lines, the refrigerant D has a refrigerating capacity ratio of 80% or more relative to R410A, a GWP of 125 or less, and a WCF lower flammability.

[0537] The results also indicate that under the condition that the mass % of HFO-1132(E), R32, and R1234yf based on their sum is respectively represented by x, y, and z, when coordinates (x,y,z) in a ternary composition diagram in which the sum of HFO-1132(E), R32, and R1234yf is 100 mass % are within the range of a figure surrounded by line segments MM', M'N, NV, VG, and GM that connect the following 5 points:

- point M (52.6, 0.0, 47.4),
- point M' (39.2, 5.0, 55.8),
- point N (27.7, 18.2, 54.1),
- point V (11.0, 18.1, 70.9), and
- point G (39.6, 0.0, 60.4),

or on these line segments (excluding the points on the line segment GM),

[0538] the line segment MM' is represented by coordinates $(0.132y^2 - 3.34y + 52.6, y, -0.132y^2 + 2.34y + 47.4)$,

[0539] the line segment M'N is represented by coordinates $(0.0596y^2 - 2.2541y + 48.98, y, -0.0596y^2 + 1.2541y + 51.02)$,

[0540] the line segment VG is represented by coordinates $(0.0123y^2 - 1.8033y + 39.6, y, -0.0123y^2 + 0.8033y + 60.4)$, and

[0541] the line segments NV and GM are straight lines, the refrigerant D according to the present disclosure has a refrigerating capacity ratio of 70% or more relative to R410A, a GWP of 125 or less, and an ASHRAE lower flammability.

[0542] The results also indicate that under the condition that the mass % of HFO-1132(E), R32, and R1234yf based on their sum is respectively represented by x, y, and z, when coordinates (x,y,z) in a ternary composition diagram in which the sum of HFO-1132(E), R32, and R1234yf is 100 mass % are within the range of a figure surrounded by line segments ON, NU, and UO that connect the following 3 points:

Point O (22.6, 36.8, 40.6),

[0543] point N (27.7, 18.2, 54.1), and point U (3.9, 36.7, 59.4), or on these line segments,

[0544] the line segment ON is represented by coordinates $(0.0072y^2 - 0.6701y + 37.512, y, -0.0072y^2 - 0.3299y + 62.488)$,

[0545] the line segment NU is represented by coordinates $(0.0083y^2 - 1.7403y + 56.635, y, -0.0083y^2 + 0.7403y + 43.365)$, and

[0546] the line segment UO is a straight line, the refrigerant D according to the present disclosure has a refrigerating capacity ratio of 80% or more relative to R410A, a GWP of 250 or less, and an ASHRAE lower flammability.

[0547] The results also indicate that under the condition that the mass % of HFO-1132(E), R32, and R1234yf based on their sum is respectively represented by x, y, and z, when coordinates (x,y,z) in a ternary composition diagram in which the sum of HFO-1132(E), R32, and R1234yf is 100 mass % are within the range of a figure surrounded by line segments QR, RT, TL, LK, and KQ that connect the following 5 points:

point Q (44.6, 23.0, 32.4),

point R (25.5, 36.8, 37.7),

point T (8.6, 51.6, 39.8),

point L (28.9, 51.7, 19.4), and

point K (35.6, 36.8, 27.6),

or on these line segments,

[0548] the line segment QR is represented by coordinates $(0.0099y^2 - 1.975y + 84.765, y, -0.0099y^2 + 0.975y + 15.235)$,

[0549] the line segment RT is represented by coordinates $(0.0082y^2 - 1.8683y + 83.126, y, -0.0082y^2 + 0.8683y + 16.874)$,

[0550] the line segment LK is represented by coordinates $(0.0049y^2 - 0.8842y + 61.488, y, -0.0049y^2 - 0.1158y + 38.512)$,

[0551] the line segment KQ is represented by coordinates $(0.0095y^2 - 1.2222y + 67.676, y, -0.0095y^2 + 0.2222y + 32.324)$, and

[0552] the line segment TL is a straight line, the refrigerant D according to the present disclosure has a refrigerating capacity ratio of 92.5% or more relative to R410A, a GWP of 350 or less, and a WCF lower flammability.

[0553] The results further indicate that under the condition that the mass % of HFO-1132(E), R32, and R1234yf based on their sum is respectively represented by x, y, and z, when

coordinates (x,y,z) in a ternary composition diagram in which the sum of HFO-1132(E), R32, and R1234yf is 100 mass % are within the range of a figure surrounded by line segments PS, ST, and TP that connect the following 3 points: point P (20.5, 51.7, 27.8), point S (21.9, 39.7, 38.4), and point T (8.6, 51.6, 39.8), or on these line segments,

[0554] the line segment PS is represented by coordinates $(0.0064y^2 - 0.7103y + 40.1, y, -0.0064y^2 - 0.2897y + 59.9)$,

[0555] the line segment ST is represented by coordinates $(0.0082y^2 - 1.8683y + 83.126, y, -0.0082y^2 + 0.8683y + 16.874)$, and

[0556] the line segment TP is a straight line, the refrigerant D according to the present disclosure has a refrigerating capacity ratio of 92.5% or more relative to R410A, a GWP of 350 or less, and an ASHRAE lower flammability.

(5-5) Refrigerant E

[0557] The refrigerant E according to the present disclosure is a mixed refrigerant comprising trans-1,2-difluoroethylene (HFO-1132(E)), trifluoroethylene (HFO-1123), and difluoromethane (R32).

[0558] The refrigerant E according to the present disclosure has various properties that are desirable as an R410A-alternative refrigerant, i.e., a coefficient of performance equivalent to that of R410A and a sufficiently low GWP.

[0559] The refrigerant E according to the present disclosure is preferably a refrigerant wherein

[0560] when the mass % of HFO-1132(E), HFO-1123, and R32 based on their sum is respectively represented by x, y, and z, coordinates (x,y,z) in a ternary composition diagram in which the sum of HFO-1132(E), HFO-1123, and R32 is 100 mass % are within the range of a figure surrounded by line segments IK, KB', B'H, HR, RG, and GI that connect the following 6 points:

point I (72.0, 28.0, 0.0),

point K (48.4, 33.2, 18.4),

point B' (0.0, 81.6, 18.4),

point H (0.0, 84.2, 15.8),

point R (23.1, 67.4, 9.5), and

point G (38.5, 61.5, 0.0),

or on these line segments (excluding the points on the line segments B'H and GI);

[0561] the line segment IK is represented by coordinates $(0.025z^2 - 1.7429z + 72.00, -0.025z^2 + 0.7429z + 28.0, z)$,

[0562] the line segment HR is represented by coordinates $(-0.3123z^2 + 4.234z + 11.06, 0.3123z^2 - 5.234z + 88.94, z)$,

[0563] the line segment RG is represented by coordinates $(-0.0491z^2 - 1.1544z + 38.5, 0.0491z^2 + 0.1544z + 61.5, z)$, and

[0564] the line segments KB' and GI are straight lines. When the requirements above are satisfied, the refrigerant according to the present disclosure has WCF lower flammability, a COP ratio of 93% or more relative to that of R410A, and a GWP of 125 or less.

[0565] The refrigerant E according to the present disclosure is preferably a refrigerant wherein

[0566] when the mass % of HFO-1132(E), HFO-1123, and R32 based on their sum is respectively represented by x, y, and z, coordinates (x,y,z) in a ternary composition diagram in which the sum of HFO-1132(E), HFO-1123, and R32 is 100 mass % are within the range of a figure surrounded by line segments IJ, JR, RG, and GI that connect the following 4 points:

point I (72.0, 28.0, 0.0),
 point J (57.7, 32.8, 9.5),
 point R (23.1, 67.4, 9.5), and
 point G (38.5, 61.5, 0.0),

or on these line segments (excluding the points on the line segment GI);

[0567] the line segment IJ is represented by coordinates $(0.025z^2 - 1.7429z + 72.0, -0.025z^2 + 0.7429z + 28.0, z)$,

[0568] the line segment RG is represented by coordinates $(-0.0491z^2 - 1.1544z + 38.5, 0.0491z^2 + 0.1544z + 61.5, z)$, and

[0569] the line segments JR and GI are straight lines. When the requirements above are satisfied, the refrigerant according to the present disclosure has WCF lower flammability, a COP ratio of 93% or more relative to that of R410A, and a GWP of 125 or less.

[0570] The refrigerant E according to the present disclosure is preferably a refrigerant wherein

[0571] when the mass % of HFO-1132(E), HFO-1123, and R32 based on their sum is respectively represented by x, y, and z, coordinates (x,y,z) in a ternary composition diagram in which the sum of HFO-1132(E), HFO-1123, and R32 is 100 mass % are within the range of a figure surrounded by line segments MP, PB', B'H, HR, RG, and GM that connect the following 6 points:

point M (47.1, 52.9, 0.0),
 point P (31.8, 49.8, 18.4),
 point B' (0.0, 81.6, 18.4),
 point H (0.0, 84.2, 15.8),
 point R (23.1, 67.4, 9.5), and
 point G (38.5, 61.5, 0.0),

or on these line segments (excluding the points on the line segments B'H and GM);

[0572] the line segment MP is represented by coordinates $(0.0083z^2 - 0.984z + 47.1, -0.0083z^2 - 0.016z + 52.9, z)$,

[0573] the line segment HR is represented by coordinates $(-0.3123z^2 + 4.234z + 11.06, 0.3123z^2 - 5.234z + 88.94, z)$,

[0574] the line segment RG is represented by coordinates $(-0.0491z^2 - 1.1544z + 38.5, 0.0491z^2 + 0.1544z + 61.5, z)$, and

[0575] the line segments PB' and GM are straight lines. When the requirements above are satisfied, the refrigerant according to the present disclosure has ASHRAE lower flammability, a COP ratio of 93% or more relative to that of R410A, and a GWP of 125 or less.

[0576] The refrigerant E according to the present disclosure is preferably a refrigerant wherein

[0577] when the mass % of HFO-1132(E), HFO-1123, and R32 based on their sum is respectively represented by x, y, and z, coordinates (x,y,z) in a ternary composition diagram in which the sum of HFO-1132(E), HFO-1123, and R32 is 100 mass % are within the range of a figure surrounded by line segments MN, NR, RG, and GM that connect the following 4 points:

point M (47.1, 52.9, 0.0),
 point N (38.5, 52.1, 9.5),
 point R (23.1, 67.4, 9.5), and
 point G (38.5, 61.5, 0.0),

or on these line segments (excluding the points on the line segment GM);

[0578] the line segment MN is represented by coordinates $(0.0083z^2 - 0.984z + 47.1, -0.0083z^2 - 0.016z + 52.9, z)$,

[0579] the line segment RG is represented by coordinates $(-0.0491z^2 - 1.1544z + 38.5, 0.0491z^2 + 0.1544z + 61.5, z)$,

[0580] the line segments NR and GM are straight lines. When the requirements above are satisfied, the refrigerant

according to the present disclosure has ASHRAE lower flammability, a COP ratio of 93% or more relative to that of R410A, and a GWP of 65 or less.

[0581] The refrigerant E according to the present disclosure is preferably a refrigerant wherein

[0582] when the mass % of HFO-1132(E), HFO-1123, and R32 based on their sum is respectively represented by x, y, and z, coordinates (x,y,z) in a ternary composition diagram in which the sum of HFO-1132(E), HFO-1123, and R32 is 100 mass % are within the range of a figure surrounded by line segments PS, ST, and TP that connect the following 3 points:

point P (31.8, 49.8, 18.4),
 point S (25.4, 56.2, 18.4), and
 point T (34.8, 51.0, 14.2),

or on these line segments;

[0583] the line segment ST is represented by coordinates $(-0.0982z^2 + 0.9622z + 40.931, 0.0982z^2 - 1.9622z + 59.069, z)$,

[0584] the line segment TP is represented by coordinates $(0.0083z^2 - 0.984z + 47.1, -0.0083z^2 - 0.016z + 52.9, z)$, and

[0585] the line segment PS is a straight line. When the requirements above are satisfied, the refrigerant according to the present disclosure has ASHRAE lower flammability, a COP ratio of 94.5% or more relative to that of R410A, and a GWP of 125 or less.

[0586] The refrigerant E according to the present disclosure is preferably a refrigerant wherein

[0587] when the mass % of HFO-1132(E), HFO-1123, and R32 based on their sum is respectively represented by x, y, and z, coordinates (x,y,z) in a ternary composition diagram in which the sum of HFO-1132(E), HFO-1123, and R32 is 100 mass % are within the range of a figure surrounded by line segments QB", B"D, DU, and UQ that connect the following 4 points:

point Q (28.6, 34.4, 37.0),
 point B" (0.0, 63.0, 37.0),
 point D (0.0, 67.0, 33.0), and
 point U (28.7, 41.2, 30.1),

or on these line segments (excluding the points on the line segment B"D);

[0588] the line segment DU is represented by coordinates $(-3.4962z^2 + 210.71z - 3146.1, 3.4962z^2 - 211.71z + 3246.1, z)$,

[0589] the line segment UQ is represented by coordinates $(0.0135z^2 - 0.9181z + 44.133, -0.0135z^2 - 0.0819z + 55.867, z)$, and

[0590] the line segments QB" and B"D are straight lines. When the requirements above are satisfied, the refrigerant according to the present disclosure has ASHRAE lower flammability, a COP ratio of 96% or more relative to that of R410A, and a GWP of 250 or less.

[0591] The refrigerant E according to the present disclosure is preferably a refrigerant wherein

[0592] when the mass % of HFO-1132(E), HFO-1123, and R32 based on their sum is respectively represented by x, y, and z, coordinates (x,y,z) in a ternary composition diagram in which the sum of HFO-1132(E), HFO-1123, and R32 is 100 mass % are within the range of a figure surrounded by line segments Oc', c'd', d'e', e'a', and a'0 that connect the following 5 points:

point O (100.0, 0.0, 0.0),
 point c' (56.7, 43.3, 0.0),
 point d' (52.2, 38.3, 9.5),

point e' (41.8, 39.8, 18.4), and

point a' (81.6, 0.0, 18.4),

or on the line segments c'd', d'e', and e'a' (excluding the points c' and a');

[0593] the line segment c'd' is represented by coordinates $(-0.0297z^2 - 0.1915z + 56.7, 0.0297z^2 + 1.1915z + 43.3, z)$,

[0594] the line segment d'e' is represented by coordinates $(-0.0535z^2 + 0.3229z + 53.957, 0.0535z^2 + 0.6771z + 46.043, z)$, and

[0595] the line segments Oc', e'a', and a'O are straight lines. When the requirements above are satisfied, the refrigerant according to the present disclosure has a COP ratio of 92.5% or more relative to that of R410A, and a GWP of 125 or less.

[0596] The refrigerant E according to the present disclosure is preferably a refrigerant wherein

[0597] when the mass % of HFO-1132(E), HFO-1123, and R32 based on their sum is respectively represented by x, y, and z, coordinates (x,y,z) in a ternary composition diagram in which the sum of HFO-1132(E), HFO-1123, and R32 is 100 mass % are within the range of a figure surrounded by line segments Oc, cd, de, ea', and a'O that connect the following 5 points:

point O (100.0, 0.0, 0.0),

point c (77.7, 22.3, 0.0),

point d (76.3, 14.2, 9.5),

point e (72.2, 9.4, 18.4), and

point a' (81.6, 0.0, 18.4),

or on the line segments cd, de, and ea' (excluding the points c and a');

[0598] the line segment cde is represented by coordinates $(-0.017z^2 + 0.0148z + 77.684, 0.017z^2 + 0.9852z + 22.316, z)$, and

[0599] the line segments Oc, ea', and a'O are straight lines. When the requirements above are satisfied, the refrigerant according to the present disclosure has a COP ratio of 95% or more relative to that of R410A, and a GWP of 125 or less.

[0600] The refrigerant E according to the present disclosure is preferably a refrigerant wherein

[0601] when the mass % of HFO-1132(E), HFO-1123, and R32 based on their sum is respectively represented by x, y, and z, coordinates (x,y,z) in a ternary composition diagram in which the sum of HFO-1132(E), HFO-1123, and R32 is 100 mass % are within the range of a figure surrounded by line segments Oc', c'd', d'a, and aO that connect the following 5 points:

point O (100.0, 0.0, 0.0),

point c' (56.7, 43.3, 0.0),

point d' (52.2, 38.3, 9.5), and

point a (90.5, 0.0, 9.5),

or on the line segments c'd' and d'a (excluding the points c' and a);

[0602] the line segment c'd' is represented by coordinates $(-0.0297z^2 - 0.1915z + 56.7, 0.0297z^2 + 1.1915z + 43.3, z)$, and

[0603] the line segments Oc', d'a, and aO are straight lines. When the requirements above are satisfied, the refrigerant according to the present disclosure has a COP ratio of 93.5% or more relative to that of R410A, and a GWP of 65 or less.

[0604] The refrigerant E according to the present disclosure is preferably a refrigerant wherein

[0605] when the mass % of HFO-1132(E), HFO-1123, and R32 based on their sum is respectively represented by x, y, and z, coordinates (x,y,z) in a ternary composition diagram in which the sum of HFO-1132(E), HFO-1123, and R32 is

100 mass % are within the range of a figure surrounded by line segments Oc, cd, da, and aO that connect the following 4 points:

point O (100.0, 0.0, 0.0),

point c (77.7, 22.3, 0.0),

point d (76.3, 14.2, 9.5), and

point a (90.5, 0.0, 9.5),

or on the line segments cd and da (excluding the points c and a);

[0606] the line segment cd is represented by coordinates $(-0.017z^2 + 0.0148z + 77.684, 0.017z^2 + 0.9852z + 22.316, z)$, and

[0607] the line segments Oc, da, and aO are straight lines. When the requirements above are satisfied, the refrigerant according to the present disclosure has a COP ratio of 95% or more relative to that of R410A, and a GWP of 65 or less.

[0608] The refrigerant E according to the present disclosure may further comprise other additional refrigerants in addition to HFO-1132(E), HFO-1123, and R32, as long as the above properties and effects are not impaired. In this respect, the refrigerant according to the present disclosure preferably comprises HFO-1132(E), HFO-1123, and R32 in a total amount of 99.5 mass % or more, more preferably 99.75 mass % or more, and even more preferably 99.9 mass % or more, based on the entire refrigerant.

[0609] Such additional refrigerants are not limited, and can be selected from a wide range of refrigerants. The mixed refrigerant may comprise a single additional refrigerant, or two or more additional refrigerants.

(Examples of Refrigerant E)

[0610] The present disclosure is described in more detail below with reference to Examples of refrigerant E. However, the refrigerant E is not limited to the Examples.

[0611] Mixed refrigerants were prepared by mixing HFO-1132(E), HFO-1123, and R32 at mass % based on their sum shown in Tables 145 and 146.

[0612] The composition of each mixture was defined as WCF. A leak simulation was performed using National Institute of Science and Technology (NIST) Standard Reference Data Base Refleak Version 4.0 under the conditions for equipment, storage, shipping, leak, and recharge according to the ASHRAE Standard 34-2013. The most flammable fraction was defined as WCFE.

[0613] For each mixed refrigerant, the burning velocity was measured according to the ANSI/ASHRAE Standard 34-2013. When the burning velocities of the WCF composition and the WCFE composition are 10 cm/s or less, the flammability of such a refrigerant is classified as Class 2L (lower flammability) in the ASHRAE flammability classification.

[0614] A burning velocity test was performed using the apparatus shown in FIG. 1 in the following manner. First, the mixed refrigerants used had a purity of 99.5% or more, and were degassed by repeating a cycle of freezing, pumping, and thawing until no traces of air were observed on the vacuum gauge. The burning velocity was measured by the closed method. The initial temperature was ambient temperature. Ignition was performed by generating an electric spark between the electrodes in the center of a sample cell. The duration of the discharge was 1.0 to 9.9 ms, and the ignition energy was typically about 0.1 to 1.0 J. The spread of the flame was visualized using schlieren photographs. A cylindrical container (inner diameter: 155 mm, length: 198

mm) equipped with two light transmission acrylic windows was used as the sample cell, and a xenon lamp was used as the light source. Schlieren images of the flame were recorded by a high-speed digital video camera at a frame rate of 600 fps and stored on a PC.

[0615] Tables 145 and 146 show the results.

TABLE 145

Item	Unit	I	J	K	L	
WCF	HFO-1132(E)	mass %	72.0	57.7	48.4	35.5
	HFO-1123	mass %	28.0	32.8	33.2	27.5
	R32	mass %	0.0	9.5	18.4	37.0
Burning velocity (WCF)	cm/s	10	10	10	10	

TABLE 146

Item	Unit	M	N	T	P	U	Q	
WCF	HFO-1132(E)	mass %	47.1	38.5	34.8	31.8	28.7	28.6
	HFO-1123	mass %	52.9	52.1	51.0	49.8	41.2	34.4
	R32	mass %	0.0	9.5	14.2	18.4	30.1	37.0
Leak condition that results in WCF		Storage, Shipping, -40° C., 92%, release, on the liquid phase side	Storage, Shipping, -40° C., 92%, release, on the liquid phase side	Storage, Shipping, -40° C., 92%, release, on the liquid phase side	Storage, Shipping, -40° C., 92%, release, on the liquid phase side	Storage, Shipping, -40° C., 92%, release, on the liquid phase side	Storage, Shipping, -40° C., 92%, release, on the liquid phase side	
WCF	HFO-1132(E)	mass %	72.0	58.9	51.5	44.6	31.4	27.1
	HFO-1123	mass %	28.0	32.4	33.1	32.6	23.2	18.3
	R32	mass %	0.0	8.7	15.4	22.8	45.4	54.6
Burning velocity (WCF)	cm/s	8 or less	8 or less	8 or less	8 or less	8 or less	8 or less	
Burning velocity (WCF)	cm/s	10	10	10	10	10	10	

[0616] The results in Table 1 indicate that in a ternary composition diagram of a mixed refrigerant of HFO-1132 (E), HFO-1123, and R32 in which their sum is 100 mass %, a line segment connecting a point (0.0, 100.0, 0.0) and a point (0.0, 0.0, 100.0) is the base, the point (0.0, 100.0, 0.0) is on the left side, and the point (0.0, 0.0, 100.0) is on the right side, when coordinates (x,y,z) are on or below line segments IK and KL that connect the following 3 points: point I (72.0, 28.0, 0.0), point K (48.4, 33.2, 18.4), and point L (35.5, 27.5, 37.0);

the line segment IK is represented by coordinates $(0.025z^2 - 1.7429z + 72.00, -0.025z^2 + 0.7429z + 28.00, z)$, and the line segment KL is represented by coordinates $(0.0098z^2 - 1.238z + 67.852, -0.0098z^2 + 0.238z + 32.148, z)$, it can be determined that the refrigerant has WCF lower flammability.

[0617] For the points on the line segment IK, an approximate curve $(x=0.025z^2 - 1.7429z + 72.00)$ was obtained from three points, i.e., I (72.0, 28.0, 0.0), J (57.7, 32.8, 9.5), and K (48.4, 33.2, 18.4) by using the least-square method to determine coordinates $(x=0.025z^2 - 1.7429z + 72.00, y=100 - z - x = -0.00922z^2 + 0.2114z + 32.443, z)$.

[0618] Likewise, for the points on the line segment KL, an approximate curve was determined from three points, i.e., K (48.4, 33.2, 18.4), Example 10 (41.1, 31.2, 27.7), and L (35.5, 27.5, 37.0) by using the least-square method to determine coordinates.

[0619] The results in Table 146 indicate that in a ternary composition diagram of a mixed refrigerant of HFO-1132 (E), HFO-1123, and R32 in which their sum is 100 mass %, a line segment connecting a point (0.0, 100.0, 0.0) and a point (0.0, 0.0, 100.0) is the base, the point (0.0, 100.0, 0.0) is on the left side, and the point (0.0, 0.0, 100.0) is on the right side, when coordinates (x,y,z) are on or below line segments MP and PQ that connect the following 3 points: point M (47.1, 52.9, 0.0), point P (31.8, 49.8, 18.4), and point Q (28.6, 34.4, 37.0), it can be determined that the refrigerant has ASHRAE lower flammability.

[0620] In the above, the line segment MP is represented by coordinates $(0.0083z^2 - 0.984z + 47.1, -0.0083z^2 - 0.016z + 52.9, z)$, and the line segment PQ is represented by coordinates $(0.0135z^2 - 0.9181z + 44.133, -0.0135z^2 - 0.0819z + 55.867, z)$.

[0621] For the points on the line segment MP, an approximate curve was obtained from three points, i.e., points M, N, and P, by using the least-square method to determine coordinates. For the points on the line segment PQ, an approximate curve was obtained from three points, i.e., points P, U, and Q, by using the least-square method to determine coordinates.

[0622] The GWP of compositions each comprising a mixture of R410A (R32=50%/R125=50%) was evaluated based on the values stated in the Intergovernmental Panel on Climate Change (IPCC), fourth report. The GWP of HFO-1132(E), which was not stated therein, was assumed to be 1 from HFO-1132a (GWP=1 or less) and HFO-1123 (GWP=0.3, described in Patent Literature 1). The refrigerating capacity of compositions each comprising R410A and a mixture of HFO-1132(E) and HFO-1123 was determined by performing theoretical refrigeration cycle calculations for the mixed refrigerants using the National Institute of Science and Technology (NIST) and Reference Fluid Thermodynamic and Transport Properties Database (Refprop 9.0) under the following conditions.

[0623] The COP ratio and the refrigerating capacity (which may be referred to as “cooling capacity” or “capacity”) ratio relative to those of R410 of the mixed refrigerants were determined. The conditions for calculation were as described below.

- Evaporating temperature: 5° C.
- Condensation temperature: 45° C.
- Degree of superheating: 5K
- Degree of subcooling: 5K
- Compressor efficiency: 70%

[0624] Tables 147 to 166 show these values together with the GWP of each mixed refrigerant.

TABLE 147

Item	Unit	Comparative Example 1	Comparative Example 2 A	Comparative Example 3 B	Comparative Example 4 A'	Comparative Example 5 B'	Comparative Example 6 A''	Comparative Example 7 B''
HFO-1132(E)	mass %	R410A	90.5	0.0	81.6	0.0	63.0	0.0
HFO-1123	mass %		0.0	90.5	0.0	81.6	0.0	63.0
R32	mass %		9.5	9.5	18.4	18.4	37.0	37.0
GWP	—	2088	65	65	125	125	250	250
COP ratio	% (relative to R410A)	100	99.1	92.0	98.7	93.4	98.7	96.1
Refrigerating capacity ratio	% (relative to R410A)	100	102.2	111.6	105.3	113.7	110.0	115.4

TABLE 148

Item	Unit	Comparative Example 8 O	Comparative Example 9 C	Comparative Example 10	Example 1 U	Example 2	Comparative Example 11 D
HFO-1132(E)	mass %	100.0	50.0	41.1	28.7	15.2	0.0
HFO-1123	mass %	0.0	31.6	34.6	41.2	52.7	67.0
R32	mass %	0.0	18.4	24.3	30.1	32.1	33.0
GWP	—	1	125	165	204	217	228
COP ratio	% (relative to R410A)	99.7	96.0	96.0	96.0	96.0	96.0
Refrigerating capacity ratio	% (relative to R410A)	98.3	109.9	111.7	113.5	114.8	115.4

TABLE 149

Item	Unit	Comparative Example 12 E	Comparative Example 13	Example 3 T	Example 4 S	Comparative Example 14 F
HFO-1132(E)	mass %	53.4	43.4	34.8	25.4	0.0
HFO-1123	mass %	46.6	47.1	51.0	56.2	74.1
R32	mass %	0.0	9.5	14.2	18.4	25.9
GWP	—	1	65	97	125	176
COP ratio	% (relative to R410A)	94.5	94.5	94.5	94.5	94.5
Refrigerating capacity ratio	% (relative to R410A)	105.6	109.2	110.8	112.3	114.8

TABLE 150

Item	Unit	Comparative Example 15 G	Example 5	Example 6 R	Example 7	Comparative Example 16 H
HFO-1132(E)	mass %	38.5	31.5	23.1	16.9	0.0
HFO-1123	mass %	61.5	63.5	67.4	71.1	84.2
R32	mass %	0.0	5.0	9.5	12.0	15.8
GWP	—	1	35	65	82	107
COP ratio	% (relative to R410A)	93.0	93.0	93.0	93.0	93.0
Refrigerating capacity ratio	% (relative to R410A)	107.0	109.1	110.9	111.9	113.2

TABLE 151

Item	Unit	Comparative Example 17 I	Example 8 J	Example 9 K	Comparative Example 18	Comparative Example 19 L
HFO-1132(E)	mass %	72.0	57.7	48.4	41.1	35.5
HFO-1123	mass %	28.0	32.8	33.2	31.2	27.5
R32	mass %	0.0	9.5	18.4	27.7	37.0
GWP	—	1	65	125	188	250

TABLE 151-continued

Item	Unit	Comparative Example 17 I	Example 8 J	Example 9 K	Comparative Example 18	Comparative Example 19 L
COP ratio	% (relative to R410A)	96.6	95.8	95.9	96.4	97.1
Refrigerating capacity ratio	% (relative to R410A)	103.1	107.4	110.1	112.1	113.2

TABLE 152

Item	Unit	Comparative Example 20 M	Example 10 N	Example 11 P	Example 12 Q
HFO-1132(E)	mass %	47.1	38.5	31.8	28.6
HFO-1123	mass %	52.9	52.1	49.8	34.4
R32	mass %	0.0	9.5	18.4	37.0
GWP	—	1	65	125	250

TABLE 152-continued

Item	Unit	Comparative Example 20 M	Example 10 N	Example 11 P	Example 12 Q
COP ratio	% (relative to R410A)	93.9	94.1	94.7	96.9
Refrigerating capacity ratio	% (relative to R410A)	106.2	109.7	112.0	114.1

TABLE 153

Item	Unit	Comparative Example 22	Comparative Example 23	Comparative Example 24	Example 14	Example 15	Example 16	Comparative Example 25	Comparative Example 26
HFO-1132(E)	mass %	10.0	20.0	30.0	40.0	50.0	60.0	70.0	80.0
HFO-1123	mass %	85.0	75.0	65.0	55.0	45.0	35.0	25.0	15.0
R32	mass %	5.0	5.0	5.0	5.0	5.0	5.0	5.0	5.0
GWP	—	35	35	35	35	35	35	35	35
COP ratio	% (relative to R410A)	91.7	92.2	92.9	93.7	94.6	95.6	96.7	97.7
Refrigerating capacity ratio	% (relative to R410A)	110.1	109.8	109.2	108.4	107.4	106.1	104.7	103.1

TABLE 154

Item	Unit	Comparative Example 27	Comparative Example 28	Comparative Example 29	Example 17	Example 18	Example 19	Comparative Example 30	Comparative Example 31
HFO-1132(E)	mass %	90.0	10.0	20.0	30.0	40.0	50.0	60.0	70.0
HFO-1123	mass %	5.0	80.0	70.0	60.0	50.0	40.0	30.0	20.0
R32	mass %	5.0	10.0	10.0	10.0	10.0	10.0	10.0	10.0
GWP	—	35	68	68	68	68	68	68	68
COP ratio	% (relative to R410A)	98.8	92.4	92.9	93.5	94.3	95.1	96.1	97.0
Refrigerating capacity ratio	% (relative to R410A)	101.4	111.7	111.3	110.6	109.6	108.5	107.2	105.7

TABLE 155

Item	Unit	Comparative Example 32	Example 20	Example 21	Example 22	Example 23	Example 24	Comparative Example 33	Comparative Example 34
HFO-1132(E)	mass %	80.0	10.0	20.0	30.0	40.0	50.0	60.0	70.0
HFO-1123	mass %	10.0	75.0	65.0	55.0	45.0	35.0	25.0	15.0
R32	mass %	10.0	15.0	15.0	15.0	15.0	15.0	15.0	15.0
GWP	—	68	102	102	102	102	102	102	102
COP ratio	% (relative to R410A)	98.0	93.1	93.6	94.2	94.9	95.6	96.5	97.4
Refrigerating capacity ratio	% (relative to R410A)	104.1	112.9	112.4	111.6	110.6	109.4	108.1	106.6

TABLE 156

Item	Unit	Comparative Example 35	Comparative Example 36	Comparative Example 37	Comparative Example 38	Comparative Example 39	Comparative Example 40	Comparative Example 41	Comparative Example 42
HFO-1132(E)	mass %	80.0	10.0	20.0	30.0	40.0	50.0	60.0	70.0
HFO-1123	mass %	5.0	70.0	60.0	50.0	40.0	30.0	20.0	10.0
R32	mass %	15.0	20.0	20.0	20.0	20.0	20.0	20.0	20.0
GWP	—	102	136	136	136	136	136	136	136
COP ratio	% (relative to R410A)	98.3	93.9	94.3	94.8	95.4	96.2	97.0	97.8
Refrigerating capacity ratio	% (relative to R410A)	105.0	113.8	113.2	112.4	111.4	110.2	108.8	107.3

TABLE 157

Item	Unit	Comparative Example 43	Comparative Example 44	Comparative Example 45	Comparative Example 46	Comparative Example 47	Comparative Example 48	Comparative Example 49	Comparative Example 50
HFO-1132(E)	mass %	10.0	20.0	30.0	40.0	50.0	60.0	70.0	10.0
HFO-1123	mass %	65.0	55.0	45.0	35.0	25.0	15.0	5.0	60.0
R32	mass %	25.0	25.0	25.0	25.0	25.0	25.0	25.0	30.0
GWP	—	170	170	170	170	170	170	170	203
COP ratio	% (relative to R410A)	94.6	94.9	95.4	96.0	96.7	97.4	98.2	95.3
Refrigerating capacity ratio	% (relative to R410A)	114.4	113.8	113.0	111.9	110.7	109.4	107.9	114.8

TABLE 158

Item	Unit	Comparative Example 51	Comparative Example 52	Comparative Example 53	Comparative Example 54	Comparative Example 55	Example 25	Example 26	Comparative Example 56
HFO-1132(E)	mass %	20.0	30.0	40.0	50.0	60.0	10.0	20.0	30.0
HFO-1123	mass %	50.0	40.0	30.0	20.0	10.0	55.0	45.0	35.0
R32	mass %	30.0	30.0	30.0	30.0	30.0	35.0	35.0	35.0
GWP	—	203	203	203	203	203	237	237	237
COP ratio	% (relative to R410A)	95.6	96.0	96.6	97.2	97.9	96.0	96.3	96.6
Refrigerating capacity ratio	% (relative to R410A)	114.2	113.4	112.4	111.2	109.8	115.1	114.5	113.6

TABLE 159

Item	Unit	Comparative Example 57	Comparative Example 58	Comparative Example 59	Comparative Example 60	Comparative Example 61	Comparative Example 62	Comparative Example 63	Comparative Example 64
HFO-1132(E)	mass %	40.0	50.0	60.0	10.0	20.0	30.0	40.0	50.0
HFO-1123	mass %	25.0	15.0	5.0	50.0	40.0	30.0	20.0	10.0
R32	mass %	35.0	35.0	35.0	40.0	40.0	40.0	40.0	40.0
GWP	—	237	237	237	271	271	271	271	271
COP ratio	% (relative to R410A)	97.1	97.7	98.3	96.6	96.9	97.2	97.7	98.2
Refrigerating capacity ratio	% (relative to R410A)	112.6	111.5	110.2	115.1	114.6	113.8	112.8	111.7

TABLE 160

Item	Unit	Example 27	Example 28	Example 29	Example 30	Example 31	Example 32	Example 33	Example 34
HFO-1132(E)	mass %	38.0	40.0	42.0	44.0	35.0	37.0	39.0	41.0
HFO-1123	mass %	60.0	58.0	56.0	54.0	61.0	59.0	57.0	55.0
R32	mass %	2.0	2.0	2.0	2.0	4.0	4.0	4.0	4.0
GWP	—	14	14	14	14	28	28	28	28
COP ratio	% (relative to R410A)	93.2	93.4	93.6	93.7	93.2	93.3	93.5	93.7
Refrigerating capacity ratio	% (relative to R410A)	107.7	107.5	107.3	107.2	108.6	108.4	108.2	108.0

TABLE 161

Item	Unit	Example 35	Example 36	Example 37	Example 38	Example 39	Example 40	Example 41	Example 42
HFO-1132(E)	mass %	43.0	31.0	33.0	35.0	37.0	39.0	41.0	27.0
HFO-1123	mass %	53.0	63.0	61.0	59.0	57.0	55.0	53.0	65.0
R32	mass %	4.0	6.0	6.0	6.0	6.0	6.0	6.0	8.0
GWP	—	28	41	41	41	41	41	41	55
COP ratio	% (relative to R410A)	93.9	93.1	93.2	93.4	93.6	93.7	93.9	93.0
Refrigerating capacity ratio	% (relative to R410A)	107.8	109.5	109.3	109.1	109.0	108.8	108.6	110.3

TABLE 162

Item	Unit	Example 43	Example 44	Example 45	Example 46	Example 47	Example 48	Example 49	Example 50
HFO-1132(E)	mass %	29.0	31.0	33.0	35.0	37.0	39.0	32.0	32.0
HFO-1123	mass %	63.0	61.0	59.0	57.0	55.0	53.0	51.0	50.0
R32	mass %	8.0	8.0	8.0	8.0	8.0	8.0	17.0	18.0
GWP	—	55	55	55	55	55	55	116	122
COP ratio	% (relative to R410A)	93.2	93.3	93.5	93.6	93.8	94.0	94.5	94.7
Refrigerating capacity ratio	% (relative to R410A)	110.1	110.0	109.8	109.6	109.5	109.3	111.8	111.9

TABLE 163

Item	Unit	Example 51	Example 52	Example 53	Example 54	Example 55	Example 56	Example 57	Example 58
HFO-1132(E)	mass %	30.0	27.0	21.0	23.0	25.0	27.0	11.0	13.0
HFO-1123	mass %	52.0	42.0	46.0	44.0	42.0	40.0	54.0	52.0
R32	mass %	18.0	31.0	33.0	33.0	33.0	33.0	35.0	35.0
GWP	—	122	210	223	223	223	223	237	237
COP ratio	% (relative to R410A)	94.5	96.0	96.0	96.1	96.2	96.3	96.0	96.0
Refrigerating capacity ratio	% (relative to R410A)	112.1	113.7	114.3	114.2	114.0	113.8	115.0	114.9

TABLE 164

Item	Unit	Example 59	Example 60	Example 61	Example 62	Example 63	Example 64	Example 65	Example 66
HFO-1132(E)	mass %	15.0	17.0	19.0	21.0	23.0	25.0	27.0	11.0
HFO-1123	mass %	50.0	48.0	46.0	44.0	42.0	40.0	38.0	52.0
R32	mass %	35.0	35.0	35.0	35.0	35.0	35.0	35.0	37.0
GWP	—	237	237	237	237	237	237	237	250
COP ratio	% (relative to R410A)	96.1	96.2	96.2	96.3	96.4	96.4	96.5	96.2
Refrigerating capacity ratio	% (relative to R410A)	114.8	114.7	114.5	114.4	114.2	114.1	113.9	115.1

TABLE 165

Item	Unit	Example 67	Example 68	Example 69	Example 70	Example 71	Example 72	Example 73	Example 74
HFO-1132(E)	mass %	13.0	15.0	17.0	15.0	17.0	19.0	21.0	23.0
HFO-1123	mass %	50.0	48.0	46.0	50.0	48.0	46.0	44.0	42.0
R32	mass %	37.0	37.0	37.0	0.0	0.0	0.0	0.0	0.0
GWP	—	250	250	250	237	237	237	237	237
COP ratio	% (relative to R410A)	96.3	96.4	96.4	96.1	96.2	96.2	96.3	96.4
Refrigerating capacity ratio	% (relative to R410A)	115.0	114.9	114.7	114.8	114.7	114.5	114.4	114.2

TABLE 166

Item	Unit	Example 75	Example 76	Example 77	Example 78	Example 79	Example 80	Example 81	Example 82
HFO-1132(E)	mass %	25.0	27.0	11.0	19.0	21.0	23.0	25.0	27.0
HFO-1123	mass %	40.0	38.0	52.0	44.0	42.0	40.0	38.0	36.0
R32	mass %	0.0	0.0	0.0	37.0	37.0	37.0	37.0	37.0
GWP	—	237	237	250	250	250	250	250	250
COP ratio	% (relative to R410A)	96.4	96.5	96.2	96.5	96.5	96.6	96.7	96.8
Refrigerating capacity ratio	% (relative to R410A)	114.1	113.9	115.1	114.6	114.5	114.3	114.1	114.0

[0625] The above results indicate that under the condition that the mass % of HFO-1132(E), HFO-1123, and R32 based on their sum is respectively represented by x, y, and z, when coordinates (x,y,z) in a ternary composition diagram in which the sum of HFO-1132(E), HFO-1123, and R32 is 100 mass %, a line segment connecting a point (0.0, 100.0, 0.0) and a point (0.0, 0.0, 100.0) is the base, and the point (0.0, 100.0, 0.0) is on the left side are within the range of a figure surrounded by line segments that connect the following 4 points:

point O (100.0, 0.0, 0.0),
point A" (63.0, 0.0, 37.0),
point B" (0.0, 63.0, 37.0), and
point (0.0, 100.0, 0.0),

or on these line segments,
the refrigerant has a GWP of 250 or less.

[0626] The results also indicate that when coordinates (x,y,z) are within the range of a figure surrounded by line segments that connect the following 4 points:

point O (100.0, 0.0, 0.0),
point A' (81.6, 0.0, 18.4),
point B' (0.0, 81.6, 18.4), and
point (0.0, 100.0, 0.0),

or on these line segments,
the refrigerant has a GWP of 125 or less.

[0627] The results also indicate that when coordinates (x,y,z) are within the range of a figure surrounded by line segments that connect the following 4 points:

point O (100.0, 0.0, 0.0),
point A (90.5, 0.0, 9.5),
point B (0.0, 90.5, 9.5), and
point (0.0, 100.0, 0.0),

or on these line segments,
the refrigerant has a GWP of 65 or less.

[0628] The results also indicate that when coordinates (x,y,z) are on the left side of line segments that connect the following 3 points:

point C (50.0, 31.6, 18.4),
point U (28.7, 41.2, 30.1), and
point D (52.2, 38.3, 9.5),

or on these line segments,
the refrigerant has a COP ratio of 96% or more relative to that of R410A.

[0629] In the above, the line segment CU is represented by coordinates $(-0.0538z^2+0.7888z+53.701, 0.0538z^2-1.7888z+46.299, z)$, and the line segment UD is represented by coordinates $(-3.4962z^2+210.71z-3146.1, 3.4962z^2-211.71z+3246.1, z)$.

[0630] The points on the line segment CU are determined from three points, i.e., point

[0631] C, Comparative Example 10, and point U, by using the least-square method.

[0632] The points on the line segment UD are determined from three points, i.e., point U, Example 2, and point D, by using the least-square method.

[0633] The results also indicate that when coordinates (x,y,z) are on the left side of line segments that connect the following 3 points:

point E (55.2, 44.8, 0.0),
point T (34.8, 51.0, 14.2), and
point F (0.0, 76.7, 23.3),

or on these line segments,
the refrigerant has a COP ratio of 94.5% or more relative to that of R410A.

[0634] In the above, the line segment ET is represented by coordinates $(-0.0547z^2-0.5327z+53.4, 0.0547z^2-0.4673z+46.6, z)$, and the line segment TF is represented by coordinates $(-0.0982z^2+0.9622z+40.931, 0.0982z^2-1.9622z+59.069, z)$.

[0635] The points on the line segment ET are determined from three points, i.e., point E, Example 2, and point T, by using the least-square method.

[0636] The points on the line segment TF are determined from three points, i.e., points T, S, and F, by using the least-square method.

[0637] The results also indicate that when coordinates (x,y,z) are on the left side of line segments that connect the following 3 points:

point G (0.0, 76.7, 23.3),
point R (21.0, 69.5, 9.5), and
point H (0.0, 85.9, 14.1),

or on these line segments,
the refrigerant has a COP ratio of 93% or more relative to that of R410A.

[0638] In the above, the line segment GR is represented by coordinates $(-0.0491z^2-1.1544z+38.5, 0.0491z^2+0.1544z+61.5, z)$, and the line segment RH is represented by coordinates $(-0.3123z^2+4.234z+11.06, 0.3123z^2-5.234z+88.94, z)$.

[0639] The points on the line segment GR are determined from three points, i.e., point G, Example 5, and point R, by using the least-square method.

[0640] The points on the line segment RH are determined from three points, i.e., point R, Example 7, and point H, by using the least-square method.

[0641] In contrast, as shown in, for example, Comparative Examples 8, 9, 13, 15, 17, and 18, when R32 is not contained, the concentrations of HFO-1132(E) and HFO-1123, which have a double bond, become relatively high;

this undesirably leads to deterioration, such as decomposition, or polymerization in the refrigerant compound.

[0642] The embodiments of the present disclosure have been described above, and it is understood that the embodiments and details can be modified in various ways without departing from the idea and scope of the present disclosure described in the claims.

(6) First Embodiment

[0643] An air conditioning apparatus **1** serving as a refrigeration cycle apparatus according to a first embodiment is described below with reference to FIG. **16** which is a schematic configuration diagram of a refrigerant circuit and FIG. **17** which is a schematic control block configuration diagram.

[0644] The air conditioning apparatus **1** is an apparatus that controls the condition of air in a subject space by performing a vapor compression refrigeration cycle.

[0645] The air conditioning apparatus **1** mainly includes an outdoor unit **20**, an indoor unit **30**, a liquid-side connection pipe **6** and a gas-side connection pipe **5** that connect the outdoor unit **20** and the indoor unit **30** to each other, a remote controller (not illustrated) serving as an input device and an output device, and a controller **7** that controls operations of the air conditioning apparatus **1**.

[0646] The air conditioning apparatus **1** performs a refrigeration cycle in which a refrigerant enclosed in a refrigerant circuit **10** is compressed, cooled or condensed, decompressed, heated or evaporated, and then compressed again. In the present embodiment, the refrigerant circuit **10** is filled with a refrigerant for performing a vapor compression refrigeration cycle. The refrigerant is a refrigerant containing 1,2-difluoroethylene, and can use any one of the above-described refrigerants A to E. The air conditioning apparatus **1** provided with only one indoor unit **30** may have, for example, a rated cooling capacity of 2.0 kW or more and 17.0 kW or less. In particular, in the present embodiment provided with a low-pressure receiver **26** being a refrigerant container, the rated cooling capacity is preferably 4.0 kW or more and 17.0 kW or less.

[0647] (6-1) Outdoor Unit **20**

[0648] The outdoor unit **20** is connected to the indoor unit **30** via the liquid-side connection pipe **6** and the gas-side connection pipe **5**, and constitutes a part of the refrigerant circuit **10**. The outdoor unit **20** mainly includes a compressor **21**, a four-way switching valve **22**, an outdoor heat exchanger **23**, an outdoor expansion valve **24**, an outdoor fan **25**, the low-pressure receiver **26**, a liquid-side shutoff valve **29**, and a gas-side shutoff valve **28**.

[0649] The compressor **21** is a device that compresses the refrigerant with a low pressure in the refrigeration cycle until the refrigerant becomes a high-pressure refrigerant. In this case, a compressor having a hermetically sealed structure in which a compression element (not illustrated) of positive-displacement type, such as rotary type or scroll type, is rotationally driven by a compressor motor is used as the compressor **21**. The compressor motor is for changing the capacity, and has an operational frequency that can be controlled by an inverter. Note that the compressor **21** is provided with an additional accumulator (not illustrated) on the suction side.

[0650] The four-way switching valve **22**, by switching the connection state, can switch the state between a cooling operation connection state in which the discharge side of the

compressor **21** is connected to the outdoor heat exchanger **23** and the suction side of the compressor **21** is connected to the gas-side shutoff valve **28**, and a heating operation connection state in which the discharge side of the compressor **21** is connected to the gas-side shutoff valve **28** and the suction side of the compressor **21** is connected to the outdoor heat exchanger **23**.

[0651] The outdoor heat exchanger **23** is a heat exchanger that functions as a condenser for the high-pressure refrigerant in the refrigeration cycle during cooling operation and that functions as an evaporator for the low-pressure refrigerant in the refrigeration cycle during heating operation. Note that, for the inner capacity (the volume of a fluid with which the inside can be filled) of the outdoor heat exchanger **23**, when the refrigerant circuit **10** is provided with a refrigerant container (for example, a low-pressure receiver or a high-pressure receiver, excluding the accumulator belonging to the compressor) like the present embodiment, the inner capacity is preferably 1.4 L or more and less than 5.0 L. Moreover, like the present embodiment, for the inner capacity (the volume of a fluid with which the inside can be filled) of the outdoor heat exchanger **23** included in a trunk outdoor unit **20** provided with only one outdoor fan **25**, the inner capacity is preferably 0.4 L or more and less than 3.5 L.

[0652] The outdoor fan **25** sucks outdoor air into the outdoor unit **20**, causes the outdoor air to exchange heat with the refrigerant in the outdoor heat exchanger **23**, and then generates an air flow to be discharged to the outside. The outdoor fan **25** is rotationally driven by an outdoor fan motor.

[0653] The valve opening degree of the outdoor expansion valve **24** is controllable and the outdoor expansion valve **24** is provided between a liquid-side end portion of the outdoor heat exchanger **23** and the liquid-side shutoff valve **29**.

[0654] The low-pressure receiver **26** is a container that is provided between one of the connecting ports of the four-way switching valve **22** and the suction side of the compressor **21** and that can store the refrigerant.

[0655] The liquid-side shutoff valve **29** is a manual valve disposed in a connection portion of the outdoor unit **20** with respect to the liquid-side connection pipe **6**.

[0656] The gas-side shutoff valve **28** is a manual valve disposed in a connection portion of the outdoor unit **20** with respect to the gas-side connection pipe **5**.

[0657] The outdoor unit **20** includes an outdoor-unit control unit **27** that controls operations of respective sections constituting the outdoor unit **20**. The outdoor-unit control unit **27** includes a microcomputer including a CPU, a memory, and so forth. The outdoor-unit control unit **27** is connected to an indoor-unit control unit **34** of each indoor unit **30** via a communication line, and transmits and receives a control signal and so forth. The outdoor-unit control unit **27** is electrically connected to various sensors (not illustrated) and receives signals from the respective sensors.

[0658] (6-2) Indoor Unit **30**

[0659] The indoor unit **30** is installed on a wall surface or a ceiling in a room that is a subject space. The indoor unit **30** is connected to the outdoor unit **20** via the liquid-side connection pipe **6** and the gas-side connection pipe **5**, and constitutes a part of the refrigerant circuit **10**.

[0660] The indoor unit **30** includes an indoor heat exchanger **31** and an indoor fan **32**.

[0661] The liquid side of the indoor heat exchanger 31 is connected to the liquid-side connection pipe 6, and the gas-side end thereof is connected to the gas-side connection pipe 5. The indoor heat exchanger 31 is a heat exchanger that functions as an evaporator for the low-pressure refrigerant in the refrigeration cycle during cooling operation and that functions as a condenser for the high-pressure refrigerant in the refrigeration cycle during heating operation.

[0662] The indoor fan 32 sucks indoor air into the indoor unit 30, causes the indoor air to exchange heat with the refrigerant in the indoor heat exchanger 31, and then generates an air flow to be discharged to the outside. The indoor fan 32 is rotationally driven by an indoor fan motor.

[0663] The indoor unit 30 includes an indoor-unit control unit 34 that controls operations of respective sections constituting the indoor unit 30. The indoor-unit control unit 34 includes a microcomputer including a CPU, a memory, and so forth. The indoor-unit control unit 34 is connected to the outdoor-unit control unit 27 via a communication line, and transmits and receives a control signal and so forth.

[0664] The indoor-unit control unit 34 is electrically connected to various sensors (not illustrated) provided in the indoor unit 30 and receives signals from the respective sensors.

[0665] (6-3) Details of Controller 7

[0666] In the air conditioning apparatus 1, the outdoor-unit control unit 27 is connected to the indoor-unit control unit 34 via the communication line, thereby constituting the controller 7 that controls operations of the air conditioning apparatus 1.

[0667] The controller 7 mainly includes a CPU (central processing unit) and a memory, such as a ROM or a RAM. Various processing and control by the controller 7 are provided when respective sections included in the outdoor-unit control unit 27 and/or the indoor-unit control unit 34 function together.

[0668] (6-4) Operating Modes

[0669] Operating modes are described below.

[0670] The operating modes include a cooling operating mode and a heating operating mode. The controller 7 determines whether the operating mode is the cooling operating mode or the heating operating mode and executes the determined mode based on an instruction received from the remote controller or the like.

[0671] (6-4-1) Cooling Operating Mode

[0672] In the air conditioning apparatus 1, in the cooling operating mode, the connection state of the four-way switching valve 22 is in the cooling operation connection state in which the discharge side of the compressor 21 is connected to the outdoor heat exchanger 23 and the suction side of the compressor 21 is connected to the gas-side shutoff valve 28, and the refrigerant filled in the refrigerant circuit 10 is circulated mainly sequentially in the compressor 21, the outdoor heat exchanger 23, the outdoor expansion valve 24, and the indoor heat exchanger 31.

[0673] More specifically, in the refrigerant circuit 10, when the cooling operating mode is started, the refrigerant is sucked into the compressor 21, compressed, and then discharged.

[0674] The compressor 21 performs capacity control in accordance with a cooling load required for the indoor unit 30. The capacity control is not limited and may be, for example, control in which a target value of suction pressure is set in accordance with the cooling load required for the

indoor unit 30, and the operating frequency of the compressor 21 is controlled such that the suction pressure becomes the target value.

[0675] The gas refrigerant discharged from the compressor 21 passes through the four-way switching valve 22 and flows into the gas-side end of the outdoor heat exchanger 23.

[0676] The gas refrigerant which has flowed into the gas-side end of the outdoor heat exchanger 23 exchanges heat with outdoor-side air supplied by the outdoor fan 25, hence is condensed and turns into a liquid refrigerant in the outdoor heat exchanger 23, and flows out from the liquid-side end of the outdoor heat exchanger 23.

[0677] The refrigerant which has flowed out from the liquid-side end of the outdoor heat exchanger 23 is decompressed when passing through the outdoor expansion valve 24. Note that the outdoor expansion valve 24 is controlled such that the degree of subcooling of the refrigerant flowing through the liquid-side outlet of the outdoor heat exchanger 23 satisfies a predetermined condition. The method of controlling the valve opening degree of the outdoor expansion valve 24 is not limited, and, for example, control may be performed such that the discharge temperature of the refrigerant discharged from the compressor 21 becomes a predetermined temperature, or the degree of superheating of the refrigerant discharged from the compressor 21 satisfies a predetermined condition.

[0678] The refrigerant decompressed at the outdoor expansion valve 24 passes through the liquid-side shutoff valve 29 and the liquid-side connection pipe 6, and flows into the indoor unit 30.

[0679] The refrigerant which has flowed into the indoor unit 30 flows into the indoor heat exchanger 31; exchanges heat with the indoor air supplied by the indoor fan 32, hence is evaporated, and turns into a gas refrigerant in the indoor heat exchanger 31; and flows out from the gas-side end of the indoor heat exchanger 31. The gas refrigerant which has flowed out from the gas-side end of the indoor heat exchanger 31 flows to the gas-side connection pipe 5.

[0680] The refrigerant which has flowed through the gas-side connection pipe 5 passes through the gas-side shutoff valve 28 and the four-way switching valve 22, and is sucked into the compressor 21 again.

[0681] (6-4-2) Heating Operating Mode

[0682] In the air conditioning apparatus 1, in the heating operating mode, the connection state of the four-way switching valve 22 is in the heating operation connection state in which the discharge side of the compressor 21 is connected to the gas-side shutoff valve 28 and the suction side of the compressor 21 is connected to the outdoor heat exchanger 23, and the refrigerant filled in the refrigerant circuit 10 is circulated mainly sequentially in the compressor 21, the indoor heat exchanger 31, the outdoor expansion valve 24, and the outdoor heat exchanger 23.

[0683] More specifically, in the refrigerant circuit 10, when the heating operating mode is started, the refrigerant is sucked into the compressor 21, compressed, and then discharged.

[0684] The compressor 21 performs capacity control in accordance with a heating load required for the indoor unit 30. The capacity control is not limited and may be, for example, control in which a target value of discharge pressure is set in accordance with the heating load required for

the indoor unit **30**, and the operating frequency of the compressor **21** is controlled such that the discharge pressure becomes the target value.

[0685] The gas refrigerant discharged from the compressor **21** flows through the four-way switching valve **22** and the gas-side connection pipe **5**, and then flows into the indoor unit **30**.

[0686] The refrigerant which has flowed into the indoor unit **30** flows into the gas-side end of the indoor heat exchanger **31**; exchanges heat with the indoor air supplied by the indoor fan **32**, hence is condensed, and turns into a refrigerant in a gas-liquid two-phase state or a liquid refrigerant in the indoor heat exchanger **31**; and flows out from the liquid-side end of the indoor heat exchanger **31**. The refrigerant which has flowed out from the liquid-side end of the indoor heat exchanger **31** flows to the liquid-side connection pipe **6**.

[0687] The refrigerant which has flowed through the liquid-side connection pipe **6** is decompressed to a low pressure in the refrigeration cycle at the liquid-side shutoff valve **29** and the outdoor expansion valve **24**. Note that the outdoor expansion valve **24** is controlled such that the degree of subcooling of the refrigerant flowing through the liquid-side outlet of the indoor heat exchanger **31** satisfies a predetermined condition. The method of controlling the valve opening degree of the outdoor expansion valve **24** is not limited, and, for example, control may be performed such that the discharge temperature of the refrigerant discharged from the compressor **21** becomes a predetermined temperature, or the degree of superheating of the refrigerant discharged from the compressor **21** satisfies a predetermined condition.

[0688] The refrigerant decompressed at the outdoor expansion valve **24** flows into the liquid-side end of the outdoor heat exchanger **23**.

[0689] The refrigerant which has flowed in from the liquid-side end of the outdoor heat exchanger **23** exchanges heat with the outdoor air supplied by the outdoor fan **25**, hence is evaporated and turns into a gas refrigerant in the outdoor heat exchanger **23**, and flows out from the gas-side end of the outdoor heat exchanger **23**.

[0690] The refrigerant which has flowed out from the gas-side end of the outdoor heat exchanger **23** passes through the four-way switching valve **22** and is sucked into the compressor **21** again.

[0691] (6-5) Refrigerant Enclosure Amount

[0692] In the air conditioning apparatus **1** provided with only the above-described one indoor unit **30**, the refrigerant circuit **10** is filled with the refrigerant by an enclosure amount of 160 g or more and 560 g or less per 1 kW of refrigeration capacity. In particular, in the air conditioning apparatus **1** provided with the low-pressure receiver **26** as a refrigerant container, the refrigerant circuit **10** is filled with the refrigerant by an enclosure amount of 260 g or more and 560 g or less per 1 kW of refrigeration capacity.

[0693] (6-6) Characteristics of First Embodiment

[0694] For example, in a refrigeration cycle apparatus using a R32 refrigerant which has been frequently used, when the filling amount of R32 is too small, an insufficiency of the refrigerant tends to decrease cycle efficiency, resulting in an increase in the LCCP; and when the filling amount of R32 is too large, the impact of the GWP tends to increase, resulting in an increase in the LCCP.

[0695] In contrast, the air conditioning apparatus **1** provided with only one indoor unit **30** according to the present embodiment uses any one of the above-described refrigerants A to E containing 1,2-difluoroethylene as the refrigerant, and the refrigerant enclosure amount is set such that the enclosure amount per 1 kW of refrigeration capacity is 160 g or more and 560 g or less (in particular, 260 g or more and 560 g or less as the low-pressure receiver **26** is provided).

[0696] Accordingly, since a refrigerant having a GWP sufficiently smaller than R32 is used and the enclosure amount per 1 kW of refrigeration capacity is not more than 560 g, the LCCP can be kept low. Moreover, even when a refrigerant having a heat-transfer capacity lower than R32 is used, since the enclosure amount per 1 kW of refrigeration capacity is 160 g or more (in particular, 260 g or more as the low-pressure receiver **26** is provided), a decrease in cycle efficiency due to an insufficiency of the refrigerant is suppressed, thereby suppressing an increase in the LCCP. As described above, when a heat cycle is performed using a sufficiently small GWP, the LCCP can be kept low.

[0697] (6-7) Modification A of First Embodiment

[0698] In the above-described first embodiment, the example of the air conditioning apparatus provided with the low-pressure receiver on the suction side of the compressor **21** has been described; however, the air conditioning apparatus may be one not be provided with a refrigerant container (a low-pressure receiver, a high-pressure receiver, or the like, excluding an accumulator belonging to a compressor) in a refrigerant circuit.

[0699] In this case, the refrigerant circuit **10** is filled with the refrigerant such that the refrigerant enclosure amount per 1 kW of refrigeration capacity is 160 g or more and 400 g or less. Moreover, in this case, the inner capacity (the volume of a fluid with which the inside can be filled) of the outdoor heat exchanger **23** is preferably 0.4 L or more and 2.5 L or less.

[0700] (6-8) Modification B of First Embodiment

[0701] In the above-described first embodiment, the example of the air conditioning apparatus provided with only one indoor unit has been described; however, the air conditioning apparatus may be one provided with a plurality of indoor units (without an indoor expansion valve) connected in parallel to one another.

[0702] In this case, the refrigerant circuit **10** is filled with the refrigerant such that the refrigerant enclosure amount per 1 kW of refrigeration capacity is 260 g or more and 560 g or less. Moreover, in this case, the inner capacity (the volume of a fluid with which the inside can be filled) of the outdoor heat exchanger **23** is preferably 1.4 L or more and less than 5.0 L.

[0703] (6-9) Modification C of First Embodiment

[0704] In the above-described first embodiment, the example of the air conditioning apparatus having the trunk outdoor unit **20** provided with only one outdoor fan **25** has been described; however, the air conditioning apparatus may be one having the trunk outdoor unit **20** provided with two outdoor fans **25**.

[0705] In this case, the refrigerant circuit **10** is filled with the refrigerant such that the refrigerant enclosure amount per 1 kW of refrigeration capacity is 350 g or more and 540 g or less. Moreover, in this case, the inner capacity (the volume of a fluid with which the inside can be filled) of the outdoor heat exchanger **23** is preferably 3.5 L or more and 7.0 L or less.

(7) Second Embodiment

[0706] An air conditioning apparatus **1a** serving as a refrigeration cycle apparatus according to a second embodiment is described below with reference to FIG. **18** which is a schematic configuration diagram of a refrigerant circuit and FIG. **19** which is a schematic control block configuration diagram.

[0707] The air conditioning apparatus **1a** according to the second embodiment is mainly described below, and portions different from the air conditioning apparatus **1** according to the first embodiment are mainly described.

[0708] Also in the air conditioning apparatus **1a**, the refrigerant circuit **10** is filled with, as a refrigerant for performing a vapor compression refrigeration cycle, a refrigerant which contains 1,2-difluoroethylene, and which is any one of the above-described refrigerants A to E.

[0709] In the outdoor unit **20** of the air conditioning apparatus **1a**, a first outdoor expansion valve **44**, an intermediate-pressure receiver **41**, and a second outdoor expansion valve **45** are sequentially provided between the liquid side of the outdoor heat exchanger **23** and the liquid-side shutoff valve **29**, instead of the outdoor expansion valve **24** of the outdoor unit **20** according to the above-described first embodiment. Moreover, the low-pressure receiver **26** of the outdoor unit **20** according to the first embodiment is not provided in the outdoor unit **20** according to the second embodiment.

[0710] The valve opening degrees of the first outdoor expansion valve **44** and the second outdoor expansion valve **45** are controllable.

[0711] The intermediate-pressure receiver **41** is a container in which both an end portion of a pipe extending from the first outdoor expansion valve **44** side and an end portion of a pipe extending from the second outdoor expansion valve **45** side are located in the inner space thereof and that can store the refrigerant.

[0712] Note that, since the air conditioning apparatus **1a** according to the second embodiment is provided with the intermediate-pressure receiver **41** that is a refrigerant container in the refrigerant circuit **10**, the inner capacity (the volume of a fluid with which the inside can be filled) of the outdoor heat exchanger **23** included in the outdoor unit **20** is preferably 1.4 L or more and less than 5.0 L. Moreover, like the present embodiment, the inner capacity (the volume of a fluid with which the inside can be filled) of the outdoor heat exchanger **23** included in a trunk outdoor unit **20** provided with only one outdoor fan **25** is preferably 0.4 L or more and less than 3.5 L.

[0713] In the air conditioning apparatus **1a**, in the cooling operating mode, the first outdoor expansion valve **44** is controlled such that the degree of subcooling of the refrigerant flowing through the liquid-side outlet of the outdoor heat exchanger **23** satisfies a predetermined condition. Also, in the cooling operating mode, the second outdoor expansion valve **45** is controlled such that the degree of superheating of the refrigerant to be sucked by the compressor **21** satisfies a predetermined condition. Note that, in the cooling operating mode, the second outdoor expansion valve **45** may be controlled such that the temperature of the refrigerant discharged from the compressor **21** becomes a predetermined temperature, or may be controlled such that the degree of superheating of the refrigerant discharged from the compressor **21** satisfies a predetermined condition.

[0714] Also, in the heating operating mode, the second outdoor expansion valve **45** is controlled such that the degree of subcooling of the refrigerant passing through the liquid-side outlet of the indoor heat exchanger **31** satisfies a predetermined condition. Also, in the cooling operating mode, the first outdoor expansion valve **44** is controlled such that the degree of superheating of the refrigerant to be sucked by the compressor **21** satisfies a predetermined condition. Note that, in the heating operating mode, the first outdoor expansion valve **44** may be controlled such that the temperature of the refrigerant discharged from the compressor **21** becomes a predetermined temperature, or may be controlled such that the degree of superheating of the refrigerant discharged from the compressor **21** satisfies a predetermined condition.

[0715] In the air conditioning apparatus **1a** provided with only the above-described one indoor unit **30**, the refrigerant circuit **10** is filled with the refrigerant by an enclosure amount of 160 g or more and 560 g or less per 1 kW of refrigeration capacity. In particular, in the air conditioning apparatus **1** provided with the intermediate-pressure receiver **41** as a refrigerant container, the refrigerant circuit **10** is filled with the refrigerant by an enclosure amount of 260 g or more and 560 g or less per 1 kW of refrigeration capacity.

[0716] The air conditioning apparatus **1** provided with only one indoor unit **30** may have a rated cooling capacity of 2.2 kW or more and 16.0 kW or less, or more preferably 4.0 kW or more and 16.0 kW or less.

[0717] Even in the air conditioning apparatus **1a** according to the second embodiment, like the air conditioning apparatus **1** according to the first embodiment, when a heat cycle is performed using a sufficiently small GWP, the LCCP can be kept low.

[0718] (7-1) Modification A of Second Embodiment

[0719] In the above-described second embodiment, the example of the air conditioning apparatus provided with only one indoor unit has been described; however, the air conditioning apparatus may be one provided with a plurality of indoor units (without an indoor expansion valve) connected in parallel to one another.

[0720] In this case, the refrigerant circuit **10** is filled with the refrigerant such that the refrigerant enclosure amount per 1 kW of refrigeration capacity is 260 g or more and 560 g or less. Moreover, in this case, the inner capacity (the volume of a fluid with which the inside can be filled) of the outdoor heat exchanger **23** is preferably 1.4 L or more and less than 5.0 L.

[0721] (7-2) Modification B of Second Embodiment

[0722] In the above-described second embodiment, the example of the air conditioning apparatus having the trunk outdoor unit **20** provided with only one outdoor fan **25** has been described; however, the air conditioning apparatus may be one having the trunk outdoor unit **20** provided with two outdoor fans **25**.

[0723] In this case, the refrigerant circuit **10** is filled with the refrigerant such that the refrigerant enclosure amount per 1 kW of refrigeration capacity is 350 g or more and 540 g or less. Moreover, in this case, the inner capacity (the volume of a fluid with which the inside can be filled) of the outdoor heat exchanger **23** is preferably 3.5 L or more and 7.0 L or less.

(8) Third Embodiment

[0724] An air conditioning apparatus *1b* serving as a refrigeration cycle apparatus according to a third embodiment is described below with reference to FIG. 20 which is a schematic configuration diagram of a refrigerant circuit and FIG. 21 which is a schematic control block configuration diagram.

[0725] The air conditioning apparatus *1b* according to the third embodiment is mainly described below, and portions different from the air conditioning apparatus *1* according to the first embodiment are mainly described.

[0726] In the air conditioning apparatus *1b*, the refrigerant circuit *10* is filled with, as a refrigerant for performing a vapor compression refrigeration cycle, a refrigerant which contains 1,2-difluoroethylene, and which is any one of the above-described refrigerants A to E.

[0727] The outdoor unit *20* of the air conditioning apparatus *1b* according to the third embodiment is obtained by providing a subcooling heat exchanger *47* and a subcooling circuit *46* in the outdoor unit *20* according to the first embodiment.

[0728] The subcooling heat exchanger *47* is provided between the outdoor expansion valve *24* and the liquid-side shutoff valve *29*.

[0729] The subcooling circuit *46* is a circuit that is branched from a main circuit between the outdoor expansion valve *24* and the subcooling heat exchanger *47* and that extends to be joined to a midway portion extending from one of the connecting ports of the four-way switching valve *22* to the low-pressure receiver *26*. The subcooling circuit *46* is provided with a subcooling expansion valve *48* that is located midway in the subcooling circuit *46* and that decompresses the refrigerant passing therethrough. The refrigerant flowing through the subcooling circuit *46* and decompressed at the subcooling expansion valve *48* exchanges heat with the refrigerant flowing through the main-circuit side in the subcooling heat exchanger *47*. Thus, the refrigerant flowing through the main-circuit side is further cooled and the refrigerant flowing through the subcooling circuit *46* is evaporated.

[0730] Note that, in the air conditioning apparatus *1b* according to the third embodiment including a plurality of indoor units each having an indoor expansion valve, the inner capacity (the volume of a fluid with which the inside can be filled) of the outdoor heat exchanger *23* included in the outdoor unit *20* is preferably 5.0 L or more and 38 L or less. In particular, when the outdoor unit *20* has a blow-out port facing a lateral side for the air which has passed through the outdoor heat exchanger *23* and is provided with two outdoor fans *25*, the inner capacity (the volume of a fluid with which the inside can be filled) of the outdoor heat exchanger *23* is preferably 7.0 L or less. When the outdoor unit *20* blows out the air which has passed through the outdoor heat exchanger *23* upward, the inner capacity is preferably 5.5 L or more.

[0731] The air conditioning apparatus *1b* according to the third embodiment includes a first indoor unit *30* and a second indoor unit *35* connected in parallel to each other, instead of the indoor unit *30* according to the first embodiment.

[0732] The first indoor unit *30* includes a first indoor heat exchanger *31*, a first indoor fan *32*, and a first indoor-unit control unit *34* like the indoor unit *30* according to the above-described first embodiment; and further a first indoor

expansion valve *33* is provided on the liquid-side of the first indoor heat exchanger *31*. The valve opening degree of the first indoor expansion valve *33* is controllable.

[0733] Similarly to the first indoor unit *30*, the second indoor unit *35* includes a second indoor heat exchanger *36*, a second indoor fan *37*, a second indoor-unit control unit *39*, and a second indoor expansion valve *38* provided on the liquid side of the second indoor heat exchanger *36*. The valve opening degree of the second indoor expansion valve *38* is controllable.

[0734] A controller *7* according to the third embodiment is constituted of an outdoor-unit control unit *27*, the first indoor-unit control unit *34*, and the second indoor-unit control unit *39* that are communicably connected to one another.

[0735] In the cooling operating mode, the outdoor expansion valve *24* is controlled such that the degree of subcooling of the refrigerant passing through the liquid-side outlet of the outdoor heat exchanger *23* satisfies a predetermined condition. Also, in the cooling operating mode, the subcooling expansion valve *48* is controlled such that the degree of superheating of the refrigerant to be sucked by the compressor *21* satisfies a predetermined condition. Note that, in the cooling operating mode, the first indoor expansion valve *33* and the second indoor expansion valve *38* are controlled to be in a fully-opened state.

[0736] In the heating operating mode, the first indoor expansion valve *33* is controlled such that the degree of subcooling of the refrigerant passing through the liquid-side outlet of the first indoor heat exchanger *31* satisfies a predetermined condition. The second indoor expansion valve *38* is likewise controlled such that the degree of subcooling of the refrigerant flowing through the liquid-side outlet of the second indoor heat exchanger *36* satisfies a predetermined condition. Also, in the heating operating mode, the outdoor expansion valve *45* is controlled such that the degree of superheating of the refrigerant to be sucked by the compressor *21* satisfies a predetermined condition. Note that, in the heating operating mode, the subcooling expansion valve *48* is controlled such that the degree of superheating of the refrigerant to be sucked by the compressor *21* satisfies a predetermined condition.

[0737] In the air conditioning apparatus *1b* provided with the above-described plurality of indoor units *30* and *35*, the refrigerant circuit *10* is filled with the refrigerant such that the enclosure amount per 1 kW of refrigeration capacity is 190 g or more and 1660 g or less.

[0738] The air conditioning apparatus *1b* provided with the plurality of indoor units *30* and *35* may have a rated cooling capacity of, for example, 4.0 kW or more and 150.0 kW or less, more preferably 14.0 kW or more and 150.0 kW or less, or further preferably 22.4 kW or more and 150.0 kW or less when the outdoor unit *20* is top blowing type.

[0739] The air conditioning apparatus *1b* provided with the plurality of indoor units according to the third embodiment uses a refrigerant which contains 1,2-difluoroethylene and which is any one of the above-described refrigerants A to E, and the refrigerant enclosure amount is set such that the enclosure amount per 1 kW of refrigeration capacity is 190 g or more and 1660 g or less.

[0740] Accordingly, also in the air conditioning apparatus *1b* provided with the plurality of indoor units, since a refrigerant having a GWP sufficiently smaller than R32 is used and the enclosure amount per 1 kW of refrigeration

capacity is not more than 1660 g, the LCCP can be kept low. Moreover, also in the air conditioning apparatus **1b** provided with the plurality of indoor units, even when a refrigerant having a heat-transfer capacity lower than R32 is used, since the enclosure amount per 1 kW of refrigeration capacity is 190 g or more, a decrease in cycle efficiency due to an insufficiency of the refrigerant is suppressed, thereby suppressing an increase in the LCCP. As described above, also in the air conditioning apparatus **1b** provided with the plurality of indoor units, when a heat cycle is performed using a refrigerant having a sufficiently small GWP, the LCCP can be kept low.

(9) Fourth Embodiment

[0741] Regarding the enclosure refrigerant amount when a refrigerant which contains 1,2-difluoroethylene and which is one of the above-described refrigerants A to E is enclosed in the refrigerant circuit, for a refrigeration cycle apparatus provided with only one indoor unit **30** like the air conditioning apparatus **1** according to the first embodiment and the air conditioning apparatus **1a** according to the second embodiment, the enclosure amount per 1 kW of refrigeration capacity is set to 160 g or more and 560 g or less; and for a refrigeration cycle apparatus provided with a plurality of indoor units **30** and **35** like the air conditioning apparatus **1b** according to the third embodiment, the enclosure amount per 1 kW of refrigeration capacity is set to 190 g or more and 1660 g or less.

[0742] Accordingly, the GWP and the LCCP can be kept low in accordance with the type of the refrigeration cycle apparatus.

[0743] The embodiments of the present disclosure have been described above, and it is understood that the embodiments and details can be modified in various ways without departing from the idea and scope of the present disclosure described in the claims.

REFERENCE SIGNS LIST

- [0744] **1**, **1a**, and **1b** air conditioning apparatus (refrigeration cycle apparatus)
- [0745] **5** gas-side connection pipe (refrigerant pipe)
- [0746] **6** liquid-side connection pipe (refrigerant pipe)
- [0747] **10** refrigerant circuit
- [0748] **20** outdoor unit (heat source unit)
- [0749] **21** compressor
- [0750] **23** outdoor heat exchanger (heat-source-side heat exchanger)
- [0751] **30** indoor unit, first indoor unit (service unit, first service unit)
- [0752] **31** indoor heat exchanger, first indoor heat exchanger (first service-side heat exchanger)
- [0753] **35** second indoor unit (second service unit)
- [0754] **36** second indoor heat exchanger (second service-side heat exchanger)

CITATION LIST

Patent Literature

- [0755] PTL 1: International Publication No. 2015/141678
 1. A refrigeration cycle apparatus comprising:
 - a heat source unit including a compressor and a heat-source-side heat exchanger;
 - a service unit including a service-side heat exchanger; and

a refrigerant pipe that connects the heat source unit and the service unit to each other,

wherein a refrigerant containing at least 1,2-difluoroethylene is enclosed in a refrigerant circuit that is constituted by connecting the compressor, the heat-source-side heat exchanger, and the service-side heat exchanger to one another, and

wherein an enclosure amount of the refrigerant in the refrigerant circuit per 1 kW of capacity satisfies a condition of 160 g or more and 560 g or less.

2. A refrigeration cycle apparatus comprising:
 - a heat source unit including a compressor and a heat-source-side heat exchanger;
 - a first service unit including a first service-side heat exchanger;
 - a second service unit including a second service-side heat exchanger; and
 - a refrigerant pipe that connects the heat source unit, the first service unit, and the second service unit to one another,

wherein a refrigerant containing at least 1,2-difluoroethylene is enclosed in a refrigerant circuit that is constituted by connecting the first service-side heat exchanger and the second service-side heat exchanger in parallel to the compressor and the heat-source-side heat exchanger, and

wherein an enclosure amount of the refrigerant in the refrigerant circuit per 1 kW of refrigeration capacity satisfies a condition of 190 g or more and 1660 g or less.

3. The refrigeration cycle apparatus according to claim 1, wherein

the refrigerant comprises trans-1,2-difluoroethylene (HFO-1132(E)), trifluoroethylene (HFO-1123), and 2,3,3,3-tetrafluoro-1-propene (R1234yf).

4. The refrigeration cycle apparatus according to claim 3, wherein

when the mass % of HFO-1132(E), HFO-1123, and R1234yf based on their sum in the refrigerant is respectively represented by x, y, and z, coordinates (x,y,z) in a ternary composition diagram in which the sum of HFO-1132(E), HFO-1123, and R1234yf is 100 mass % are within the range of a figure surrounded by line segments AA', A'B, BD, DC', C'C, CO, and OA that connect the following 7 points:

- point A (68.6, 0.0, 31.4),
- point A' (30.6, 30.0, 39.4),
- point B (0.0, 58.7, 41.3),
- point D (0.0, 80.4, 19.6),
- point C' (19.5, 70.5, 10.0),
- point C (32.9, 67.1, 0.0), and
- point O (100.0, 0.0, 0.0),

or on the above line segments (excluding the points on the line segments BD, CO, and OA);

the line segment AA' is represented by coordinates (x, $0.0016x^2 - 0.9473x + 57.497$, $-0.0016x^2 - 0.0527x + 42.503$),

the line segment A'B is represented by coordinates (x, $0.0029x^2 - 1.0268x + 58.7$, $-0.0029x^2 + 0.0268x + 41.3$),

the line segment DC' is represented by coordinates (x, $0.0082x^2 - 0.6671x + 80.4$, $-0.0082x^2 - 0.3329x + 19.6$),

the line segment C'C is represented by coordinates $(x, 0.0067x^2-0.6034x+79.729, -0.0067x^2-0.3966x+20.271)$, and

the line segments BD, CO, and OA are straight lines.

5. The refrigeration cycle apparatus according to claim 3, wherein

when the mass % of HFO-1132(E), HFO-1123, and R1234yf based on their sum in the refrigerant is respectively represented by x, y, and z, coordinates (x,y,z) in a ternary composition diagram in which the sum of HFO-1132(E), HFO-1123, and R1234yf is 100 mass % are within the range of a figure surrounded by line segments GI, IA, AA', A'B, BD, DC', C'C, and CG that connect the following 8 points:

point G (72.0, 28.0, 0.0),
point I (72.0, 0.0, 28.0),
point A (68.6, 0.0, 31.4),
point A' (30.6, 30.0, 39.4),
point B (0.0, 58.7, 41.3),
point D (0.0, 80.4, 19.6),
point C' (19.5, 70.5, 10.0), and
point C (32.9, 67.1, 0.0),

or on the above line segments (excluding the points on the line segments IA, BD, and CG);

the line segment AA' is represented by coordinates $(x, 0.0016x^2-0.9473x+57.497, -0.0016x^2-0.0527x+42.503)$,

the line segment A'B is represented by coordinates $(x, 0.0029x^2-1.0268x+58.7, -0.0029x^2+0.0268x+41.3)$,

the line segment DC' is represented by coordinates $(x, 0.0082x^2-0.6671x+80.4, -0.0082x^2-0.3329x+19.6)$,

the line segment C'C is represented by coordinates $(x, 0.0067x^2-0.6034x+79.729, -0.0067x^2-0.3966x+20.271)$, and

the line segments GI, IA, BD, and CG are straight lines.

6. The refrigeration cycle apparatus according to claim 3, wherein

when the mass % of HFO-1132(E), HFO-1123, and R1234yf based on their sum in the refrigerant is respectively represented by x, y, and z, coordinates (x,y,z) in a ternary composition diagram in which the sum of HFO-1132(E), HFO-1123, and R1234yf is 100 mass % are within the range of a figure surrounded by line segments JP, PN, NK, KA', A'B, BD, DC', C'C, and CJ that connect the following 9 points:

point J (47.1, 52.9, 0.0),
point P (55.8, 42.0, 2.2),
point N (68.6, 16.3, 15.1),
point K (61.3, 5.4, 33.3),
point A' (30.6, 30.0, 39.4),
point B (0.0, 58.7, 41.3),
point D (0.0, 80.4, 19.6),
point C' (19.5, 70.5, 10.0), and
point C (32.9, 67.1, 0.0),

or on the above line segments (excluding the points on the line segments BD and CJ);

the line segment PN is represented by coordinates $(x, -0.1135x^2+12.112x-280.43, 0.1135x^2-13.112x+380.43)$,

the line segment NK is represented by coordinates $(x, 0.2421x^2-29.955x+931.91, -0.2421x^2+28.955x-831.91)$,

the line segment KA' is represented by coordinates $(x, 0.0016x^2-0.9473x+57.497, -0.0016x^2-0.0527x+42.503)$,

the line segment A'B is represented by coordinates $(x, 0.0029x^2-1.0268x+58.7, -0.0029x^2+0.0268x+41.3)$,

the line segment DC' is represented by coordinates $(x, 0.0082x^2-0.6671x+80.4, -0.0082x^2-0.3329x+19.6)$,

the line segment C'C is represented by coordinates $(x, 0.0067x^2-0.6034x+79.729, -0.0067x^2-0.3966x+20.271)$, and

the line segments JP, BD, and CG are straight lines.

7. The refrigeration cycle apparatus according to claim 3, wherein

when the mass % of HFO-1132(E), HFO-1123, and R1234yf based on their sum in the refrigerant is respectively represented by x, y, and z, coordinates (x,y,z) in a ternary composition diagram in which the sum of HFO-1132(E), HFO-1123, and R1234yf is 100 mass % are within the range of a figure surrounded by line segments JP, PL, LM, MA', A'B, BD, DC', C'C, and CJ that connect the following 9 points:

point J (47.1, 52.9, 0.0),
point P (55.8, 42.0, 2.2),
point L (63.1, 31.9, 5.0),
point M (60.3, 6.2, 33.5),
point A' (30.6, 30.0, 39.4),
point B (0.0, 58.7, 41.3),
point D (0.0, 80.4, 19.6),
point C' (19.5, 70.5, 10.0), and
point C (32.9, 67.1, 0.0),

or on the above line segments (excluding the points on the line segments BD and CJ);

the line segment PL is represented by coordinates $(x, -0.1135x^2+12.112x-280.43, 0.1135x^2-13.112x+380.43)$

the line segment MA' is represented by coordinates $(x, 0.0016x^2-0.9473x+57.497, -0.0016x^2-0.0527x+42.503)$,

the line segment A'B is represented by coordinates $(x, 0.0029x^2-1.0268x+58.7, -0.0029x^2+0.0268x+41.3)$,

the line segment DC' is represented by coordinates $(x, 0.0082x^2-0.6671x+80.4, -0.0082x^2-0.3329x+19.6)$,

the line segment C'C is represented by coordinates $(x, 0.0067x^2-0.6034x+79.729, -0.0067x^2-0.3966x+20.271)$, and

the line segments JP, LM, BD, and CG are straight lines.

8. The refrigeration cycle apparatus according to claim 3, wherein

when the mass % of HFO-1132(E), HFO-1123, and R1234yf based on their sum in the refrigerant is respectively represented by x, y, and z, coordinates (x,y,z) in a ternary composition diagram in which the sum of HFO-1132(E), HFO-1123, and R1234yf is 100 mass % are within the range of a figure surrounded by line segments PL, LM, MA', A'B, BF, FT, and TP that connect the following 7 points:

point P (55.8, 42.0, 2.2),
point L (63.1, 31.9, 5.0),
point M (60.3, 6.2, 33.5),
point A' (30.6, 30.0, 39.4),
point B (0.0, 58.7, 41.3),
point F (0.0, 61.8, 38.2), and
point T (35.8, 44.9, 19.3),

or on the above line segments (excluding the points on the line segment BF);

the line segment PL is represented by coordinates $(x, -0.1135x^2+12.112x-280.43, 0.1135x^2-13.112x+380.43)$,

the line segment MA' is represented by coordinates $(x, 0.0016x^2-0.9473x+57.497, -0.0016x^2-0.0527x+42.503)$,

the line segment A'B is represented by coordinates $(x, 0.0029x^2-1.0268x+58.7, -0.0029x^2+0.0268x+41.3)$,

the line segment FT is represented by coordinates $(x, 0.0078x^2-0.7501x+61.8, -0.0078x^2-0.2499x+38.2)$,

the line segment TP is represented by coordinates $(0.00672x^2-0.7607x+63.525, -0.00672x^2-0.2393x+36.475)$, and

the line segments LM and BF are straight lines.

9. The refrigeration cycle apparatus according to claim 3, wherein

when the mass % of HFO-1132(E), HFO-1123, and R1234yf based on their sum in the refrigerant is respectively represented by x, y, and z, coordinates (x,y,z) in a ternary composition diagram in which the sum of HFO-1132(E), HFO-1123, and R1234yf is 100 mass % are within the range of a figure surrounded by line segments PL, LQ, QR, and RP that connect the following 4 points:

point P (55.8, 42.0, 2.2),

point L (63.1, 31.9, 5.0),

point Q (62.8, 29.6, 7.6), and

point R (49.8, 42.3, 7.9),

or on the above line segments;

the line segment PL is represented by coordinates $(x, -0.1135x^2+12.112x-280.43, 0.1135x^2-13.112x+380.43)$,

the line segment RP is represented by coordinates $(x, 0.00672x^2-0.7607x+63.525, -0.00672x^2-0.2393x+36.475)$, and

the line segments LQ and QR are straight lines.

10. The refrigeration cycle apparatus according to claim 3,

wherein

when the mass % of HFO-1132(E), HFO-1123, and R1234yf based on their sum in the refrigerant is respectively represented by x, y, and z, coordinates (x,y,z) in a ternary composition diagram in which the sum of HFO-1132(E), HFO-1123, and R1234yf is 100 mass % are within the range of a figure surrounded by line segments SM, MA', A'B, BF, FT, and TS that connect the following 6 points:

point S (62.6, 28.3, 9.1),

point M (60.3, 6.2, 33.5),

point A' (30.6, 30.0, 39.4),

point B (0.0, 58.7, 41.3),

point F (0.0, 61.8, 38.2), and

point T (35.8, 44.9, 19.3),

or on the above line segments,

the line segment MA' is represented by coordinates $(x, 0.0016x^2-0.9473x+57.497, -0.0016x^2-0.0527x+42.503)$,

the line segment A'B is represented by coordinates $(x, 0.0029x^2-1.0268x+58.7, -0.0029x^2+0.0268x+41.3)$,

the line segment FT is represented by coordinates $(x, 0.0078x^2-0.7501x+61.8, -0.0078x^2-0.2499x+38.2)$,

the line segment TS is represented by coordinates $(x, -0.0017x^2-0.7869x+70.888, -0.0017x^2-0.2131x+29.112)$, and

the line segments SM and BF are straight lines.

11. The refrigeration cycle apparatus according to claim 1, wherein

the refrigerant comprises trans-1,2-difluoroethylene (HFO-1132(E)) and trifluoroethylene (HFO-1123) in a total amount of 99.5 mass % or more based on the entire refrigerant, and

the refrigerant comprises 62.0 mass % to 72.0 mass % of HFO-1132(E) based on the entire refrigerant.

12. The refrigeration cycle apparatus according to claim 1,

wherein

the refrigerant comprises trans-1,2-difluoroethylene (HFO-1132(E)), and trifluoroethylene (HFO-1123) in a total amount of 99.5 mass % or more based on the entire refrigerant, and

the refrigerant comprises 45.1 mass % to 47.1 mass % of HFO-1132(E) based on the entire refrigerant.

13. The refrigeration cycle apparatus according to claim 1,

wherein

the refrigerant comprises trans-1,2-difluoroethylene (HFO-1132(E)), trifluoroethylene (HFO-1123), 2,3,3,3-tetrafluoro-1-propene (R1234yf), and difluoromethane (R32),

wherein

when the mass % of HFO-1132(E), HFO-1123, R1234yf, and R32 based on their sum in the refrigerant is respectively represented by x, y, z, and a,

if $0 < a \leq 11.1$, coordinates (x,y,z) in a ternary composition diagram in which the sum of HFO-1132(E), HFO-1123, and R1234yf is $(100-a)$ mass % are within the range of a figure surrounded by straight lines GI, IA, AB, BD', D'C, and CG that connect the following 6 points:

point G $(0.026a^2-1.7478a+72.0, -0.026a^2+0.7478a+28.0, 0.0)$,

point I $(0.026a^2-1.7478a+72.0, 0.0, -0.026a^2+0.7478a+28.0)$,

point A $(0.0134a^2-1.9681a+68.6, 0.0, -0.0134a^2+0.9681a+31.4)$,

point B $(0.0, 0.0144a^2-1.6377a+58.7, -0.0144a^2+0.6377a+41.3)$,

point D' $(0.0, 0.0224a^2+0.968a+75.4, -0.0224a^2-1.968a+24.6)$, and

point C $(-0.2304a^2-0.4062a+32.9, 0.2304a^2-0.5938a+67.1, 0.0)$,

or on the straight lines GI, AB, and D'C (excluding point G, point I, point A, point B, point D', and point C);

if $11.1 < a \leq 18.2$, coordinates (x,y,z) in the ternary composition diagram are within the range of a figure surrounded by straight lines GI, IA, AB, BW, and WG that connect the following 5 points:

point G $(0.02a^2-1.6013a+71.105, -0.02a^2+0.6013a+28.895, 0.0)$,

point I $(0.02a^2-1.6013a+71.105, 0.0, -0.02a^2+0.6013a+28.895)$,

point A $(0.0112a^2-1.9337a+68.484, 0.0, -0.0112a^2+0.9337a+31.516)$,

point B $(0.0, 0.0075a^2-1.5156a+58.199, -0.0075a^2+0.5156a+41.801)$, and

point W $(0.0, 100.0-a, 0.0)$,

or on the straight lines GI and AB (excluding point G, point I, point A, point B, and point W);

if $18.2 < a \leq 26.7$, coordinates (x,y,z) in the ternary composition diagram are within the range of a figure surrounded by straight lines GI, IA, AB, BW, and WG that connect the following 5 points:

point G (0.0135a²-1.4068a+69.727, -0.0135a²+0.4068a+30.273, 0.0),

point I (0.0135a²-1.4068a+69.727, 0.0, -0.0135a²+0.4068a+30.273),

point A (0.0107a²-1.9142a+68.305, 0.0, -0.0107a²+0.9142a+31.695),

point B (0.0, 0.009a²-1.6045a+59.318, -0.009a²+0.6045a+40.682), and

point W (0.0, 100.0-a, 0.0),

or on the straight lines GI and AB (excluding point G, point I, point A, point B, and point W);

if $26.7 < a \leq 36.7$, coordinates (x,y,z) in the ternary composition diagram are within the range of a figure surrounded by straight lines GI, IA, AB, BW, and WG that connect the following 5 points:

point G (0.0111a²-1.3152a+68.986, -0.0111a²+0.3152a+31.014, 0.0),

point I (0.0111a²-1.3152a+68.986, 0.0, -0.0111a²+0.3152a+31.014),

point A (0.0103a²-1.9225a+68.793, 0.0, -0.0103a²+0.9225a+31.207),

point B (0.0, 0.0046a²-1.41a+57.286, -0.0046a²+0.41a+42.714), and

point W (0.0, 100.0-a, 0.0),

or on the straight lines GI and AB (excluding point G, point I, point A, point B, and point W); and

if $36.7 < a \leq 46.7$, coordinates (x,y,z) in the ternary composition diagram are within the range of a figure surrounded by straight lines GI, IA, AB, BW, and WG that connect the following 5 points:

point G (0.0061a²-0.9918a+63.902, -0.0061a²-0.0082a+36.098, 0.0),

point I (0.0061a²-0.9918a+63.902, 0.0, -0.0061a²-0.0082a+36.098),

point A (0.0085a²-1.8102a+67.1, 0.0, -0.0085a²+0.8102a+32.9),

point B (0.0, 0.0012a²-1.1659a+52.95, -0.0012a²+0.1659a+47.05), and

point W (0.0, 100.0-a, 0.0),

or on the straight lines GI and AB (excluding point G, point I, point A, point B, and point W).

14. The refrigeration cycle apparatus according to claim 1,

wherein

the refrigerant comprises trans-1,2-difluoroethylene (HFO-1132(E)), trifluoroethylene (HFO-1123), 2,3,3,3-tetrafluoro-1-propene (R1234yf), and difluoromethane (R32),

wherein

when the mass % of HFO-1132(E), HFO-1123, R1234yf, and R32 based on their sum in the refrigerant is respectively represented by x, y, z, and a,

if $0 < a \leq 11.1$, coordinates (x,y,z) in a ternary composition diagram in which the sum of HFO-1132(E), HFO-1123, and R1234yf is (100-a) mass % are within the range of a figure surrounded by straight lines JK', K'B, BD', D'C, and CJ that connect the following 5 points:

point J (0.0049a²-0.9645a+47.1, -0.0049a²-0.0355a+52.9, 0.0),

point K' (0.0514a²-2.4353a+61.7, -0.0323a²+0.4122a+5.9, -0.0191a²+1.0231a+32.4),

point B (0.0, 0.0144a²-1.6377a+58.7, -0.0144a²+0.6377a+41.3),

point D' (0.0, 0.0224a²+0.968a+75.4, -0.0224a²-1.968a+24.6), and

point C (-0.2304a²-0.4062a+32.9, 0.2304a²-0.5938a+67.1, 0.0),

or on the straight lines JK', K'B, and D'C (excluding point J, point B, point D', and point C);

if $11.1 < a \leq 18.2$, coordinates (x,y,z) in the ternary composition diagram are within the range of a figure surrounded by straight lines JK', K'B, BW, and WJ that connect the following 4 points:

point J (0.0243a²-1.4161a+49.725, -0.0243a²+0.4161a+50.275, 0.0),

point K' (0.0341a²-2.1977a+61.187, -0.0236a²+0.34a+5.636, -0.0105a²+0.8577a+33.177),

point B (0.0, 0.0075a²-1.5156a+58.199, -0.0075a²+0.5156a+41.801), and

point W (0.0, 100.0-a, 0.0),

or on the straight lines JK' and K'B (excluding point J, point B, and point W);

if $18.2 < a \leq 26.7$, coordinates (x,y,z) in the ternary composition diagram are within the range of a figure surrounded by straight lines JK', K'B, BW, and WJ that connect the following 4 points:

point J (0.0246a²-1.4476a+50.184, -0.0246a²+0.4476a+49.816, 0.0),

point K' (0.0196a²-1.7863a+58.515, -0.0079a²-0.1136a+8.702, -0.0117a²+0.8999a+32.783),

point B (0.0, 0.009a²-1.6045a+59.318, -0.009a²+0.6045a+40.682), and

point W (0.0, 100.0-a, 0.0),

or on the straight lines JK' and K'B (excluding point J, point B, and point W);

if $26.7 < a \leq 36.7$, coordinates (x,y,z) in the ternary composition diagram are within the range of a figure surrounded by straight lines JK', K'A, AB, BW, and WJ that connect the following 5 points:

point J (0.0183a²-1.1399a+46.493, -0.0183a²+0.1399a+53.507, 0.0),

point K' (-0.0051a²+0.0929a+25.95, 0.0, 0.0051a²-1.0929a+74.05),

point A (0.0103a²-1.9225a+68.793, 0.0, -0.0103a²+0.9225a+31.207),

point B (0.0, 0.0046a²-1.41a+57.286, -0.0046a²+0.41a+42.714), and

point W (0.0, 100.0-a, 0.0),

or on the straight lines JK', K'A, and AB (excluding point J, point B, and point W); and

if $36.7 < a \leq 46.7$, coordinates (x,y,z) in the ternary composition diagram are within the range of a figure surrounded by straight lines JK', K'A, AB, BW, and WJ that connect the following 5 points:

point J (-0.0134a²+1.0956a+7.13, 0.0134a²-2.0956a+92.87, 0.0),

point K' (-1.892a+29.443, 0.0, 0.892a+70.557),

point A (0.0085a²-1.8102a+67.1, 0.0, -0.0085a²+0.8102a+32.9),

point B (0.0, $0.0012a^2-1.1659a+52.95$, $-0.0012a^2+0.1659a+47.05$), and
 point W (0.0, $100.0-a$, 0.0),
 or on the straight lines JK', K'A, and AB (excluding point J, point B, and point W).

15. The refrigeration cycle apparatus according to claim 1,

wherein
 the refrigerant comprises trans-1,2-difluoroethylene (HFO-1132(E)), difluoromethane (R32), and 2,3,3,3-tetrafluoro-1-propene (R1234yf),

wherein

when the mass % of HFO-1132(E), R32, and R1234yf based on their sum in the refrigerant is respectively represented by x, y, and z, coordinates (x,y,z) in a ternary composition diagram in which the sum of HFO-1132(E), R32, and R1234yf is 100 mass % are within the range of a figure surrounded by line segments IJ, JN, NE, and EI that connect the following 4 points:

point I (72.0, 0.0, 28.0),
 point J (48.5, 18.3, 33.2),
 point N (27.7, 18.2, 54.1), and
 point E (58.3, 0.0, 41.7),

or on these line segments (excluding the points on the line segment EI;

the line segment IJ is represented by coordinates ($0.0236y^2-1.7616y+72.0$, y, $-0.0236y^2+0.7616y+28.0$);

the line segment NE is represented by coordinates ($0.012y^2-1.9003y+58.3$, y, $-0.012y^2+0.9003y+41.7$); and

the line segments JN and EI are straight lines.

16. The refrigeration cycle apparatus according to claim 1,

wherein
 the refrigerant comprises trans-1,2-difluoroethylene (HFO-1132(E)), difluoromethane (R32), and 2,3,3,3-tetrafluoro-1-propene (R1234yf),

wherein

when the mass % of HFO-1132(E), R32, and R1234yf based on their sum in the refrigerant is respectively represented by x, y, and z, coordinates (x,y,z) in a ternary composition diagram in which the sum of HFO-1132(E), R32, and R1234yf is 100 mass % are within the range of a figure surrounded by line segments MM', M'N, NV, VG, and GM that connect the following 5 points:

point M (52.6, 0.0, 47.4),
 point M' (39.2, 5.0, 55.8),
 point N (27.7, 18.2, 54.1),
 point V (11.0, 18.1, 70.9), and
 point G (39.6, 0.0, 60.4),

or on these line segments (excluding the points on the line segment GM);

the line segment MM' is represented by coordinates ($132y^2-3.34y+52.6$, y, $-0.132y^2+2.34y+47.4$);

the line segment MN is represented by coordinates ($0.0596y^2-2.2541y+48.98$, y, $-0.0596y^2+1.2541y+51.02$);

the line segment VG is represented by coordinates ($0.0123y^2-1.8033y+39.6$, y, $-0.0123y^2+0.8033y+60.4$); and

the line segments NV and GM are straight lines.

17. The refrigeration cycle apparatus according to claim 1,

wherein

the refrigerant comprises trans-1,2-difluoroethylene (HFO-1132(E)), difluoromethane (R32), and 2,3,3,3-tetrafluoro-1-propene (R1234yf),

wherein

when the mass % of HFO-1132(E), R32, and R1234yf based on their sum in the refrigerant is respectively represented by x, y and z, coordinates (x,y,z) in a ternary composition diagram in which the sum of HFO-1132(E), R32, and R1234yf is 100 mass % are within the range of a figure surrounded by line segments ON, NU, and UO that connect the following 3 points:

point O (22.6, 36.8, 40.6),
 point N (27.7, 18.2, 54.1), and
 point U (3.9, 36.7, 59.4),

or on these line segments;

the line segment ON is represented by coordinates ($0.0072y^2-0.6701y+37.512$, y, $-0.0072y^2-0.3299y+62.488$);

the line segment NU is represented by coordinates ($0.0083y^2-1.7403y+56.635$, y, $-0.0083y^2+0.7403y+43.365$); and

the line segment UO is a straight line.

18. The refrigeration cycle apparatus according to claim 1,

wherein

the refrigerant comprises trans-1,2-difluoroethylene (HFO-1132(E)), difluoromethane (R32), and 2,3,3,3-tetrafluoro-1-propene (R1234yf),

wherein

when the mass % of HFO-1132(E), R32, and R1234yf based on their sum in the refrigerant is respectively represented by x, y, and z, coordinates (x,y,z) in a ternary composition diagram in which the sum of HFO-1132(E), R32, and R1234yf is 100 mass % are within the range of a figure surrounded by line segments QR, RT, TL, LK, and KQ that connect the following 5 points:

point Q (44.6, 23.0, 32.4),
 point R (25.5, 36.8, 37.7),
 point T (8.6, 51.6, 39.8),
 point L (28.9, 51.7, 19.4), and
 point K (35.6, 36.8, 27.6),

or on these line segments;

the line segment QR is represented by coordinates ($0.0099y^2-1.975y+84.765$, y, $-0.0099y^2+0.975y+15.235$);

the line segment RT is represented by coordinates ($0.0082y^2-1.8683y+83.126$, y, $-0.0082y^2+0.8683y+16.874$);

the line segment LK is represented by coordinates ($0.0049y^2-0.8842y+61.488$, y, $-0.0049y^2-0.1158y+38.512$);

the line segment KQ is represented by coordinates ($0.0095y^2-1.2222y+67.676$, y, $-0.0095y^2+0.2222y+32.324$); and

the line segment TL is a straight line.

19. The refrigeration cycle apparatus according to claim 1,

wherein

the refrigerant comprises trans-1,2-difluoroethylene (HFO-1132(E)),

difluoromethane (R32), and 2,3,3,3-tetrafluoro-1-propene (R1234yf),

wherein

when the mass % of HFO-1132(E), R32, and R1234yf based on their sum in the refrigerant is respectively represented by x, y, and z, coordinates (x,y,z) in a ternary composition diagram in which the sum of HFO-1132(E), R32, and R1234yf is 100 mass % are within the range of a figure surrounded by line segments PS, ST, and TP that connect the following 3 points:

point P (20.5, 51.7, 27.8),

point S (21.9, 39.7, 38.4), and

point T (8.6, 51.6, 39.8),

or on these line segments;

the line segment PS is represented by coordinates $(0.0064y^2 - 0.7103y + 40.1, y, -0.0064y^2 - 0.2897y + 59.9)$;

the line segment ST is represented by coordinates $(0.0082y^2 - 1.8683y + 83.126, y, -0.0082y^2 + 0.8683y + 16.874)$; and

the line segment TP is a straight line.

20. The refrigeration cycle apparatus according to claim 1,

wherein

the refrigerant comprises trans-1,2-difluoroethylene (HFO-1132(E)), trifluoroethylene (HFO-1123), and difluoromethane (R32),

wherein

when the mass % of HFO-1132(E), HFO-1123, and R32 based on their sum in the refrigerant is respectively represented by x, y, and z, coordinates (x,y,z) in a ternary composition diagram in which the sum of HFO-1132(E), HFO-1123, and R32 is 100 mass % are within the range of a figure surrounded by line segments IK, KB', B'H, HR, RG, and GI that connect the following 6 points:

point I (72.0, 28.0, 0.0),

point K (48.4, 33.2, 18.4),

point B' (0.0, 81.6, 18.4),

point H (0.0, 84.2, 15.8),

point R (23.1, 67.4, 9.5), and

point G (38.5, 61.5, 0.0),

or on these line segments (excluding the points on the line segments B'H and GI);

the line segment IK is represented by coordinates $(0.025z^2 - 1.7429z + 72.00, -0.025z^2 + 0.7429z + 28.0, z)$,

the line segment HR is represented by coordinates $(-0.3123z^2 + 4.234z + 11.06, 0.3123z^2 - 5.234z + 88.94, z)$,

the line segment RG is represented by coordinates $(-0.0491z^2 - 1.1544z + 38.5, 0.0491z^2 + 0.1544z + 61.5, z)$, and the line segments KB' and GI are straight lines.

21. The refrigeration cycle apparatus according to claim 1,

wherein

the refrigerant comprises trans-1,2-difluoroethylene (HFO-1132(E)), trifluoroethylene (HFO-1123), and difluoromethane (R32),

wherein

when the mass % of HFO-1132(E), HFO-1123, and R32 based on their sum in the refrigerant is respectively represented by x, y, and z, coordinates (x,y,z) in a ternary composition diagram in which the sum of HFO-1132(E), HFO-1123, and R32 is 100 mass % are

within the range of a figure surrounded by line segments U, JR, RG, and GI that connect the following 4 points:

point I (72.0, 28.0, 0.0),

point J (57.7, 32.8, 9.5),

point R (23.1, 67.4, 9.5), and

point G (38.5, 61.5, 0.0),

or on these line segments (excluding the points on the line segment GI);

the line segment U is represented by coordinates $(0.025z^2 - 1.7429z + 72.0, -0.025z^2 + 0.7429z + 28.0, z)$,

the line segment RG is represented by coordinates $(-0.0491z^2 - 1.1544z + 38.5, 0.0491z^2 + 0.1544z + 61.5, z)$, and the line segments JR and GI are straight lines.

22. The refrigeration cycle apparatus according to claim 1,

wherein

the refrigerant comprises trans-1,2-difluoroethylene (HFO-1132(E)), trifluoroethylene (HFO-1123), and difluoromethane (R32),

wherein

when the mass % of HFO-1132(E), HFO-1123, and R32 based on their sum in the refrigerant is respectively represented by x, y, and z, coordinates (x,y,z) in a ternary composition diagram in which the sum of HFO-1132(E), HFO-1123, and R32 is 100 mass % are within the range of a figure surrounded by line segments MP, PB', B'H, HR, RG, and GM that connect the following 6 points:

point M (47.1, 52.9, 0.0),

point P (31.8, 49.8, 18.4),

point B' (0.0, 81.6, 18.4),

point H (0.0, 84.2, 15.8),

point R (23.1, 67.4, 9.5), and

point G (38.5, 61.5, 0.0),

or on these line segments (excluding the points on the line segments B'H and GM);

the line segment MP is represented by coordinates $(0.0083z^2 - 0.984z + 47.1, -0.0083z^2 - 0.016z + 52.9, z)$,

the line segment HR is represented by coordinates $(-0.3123z^2 + 4.234z + 11.06, 0.3123z^2 - 5.234z + 88.94, z)$,

the line segment RG is represented by coordinates $(-0.0491z^2 - 1.1544z + 38.5, 0.0491z^2 + 0.1544z + 61.5, z)$, and the line segments PB' and GM are straight lines.

23. The refrigeration cycle apparatus according to claim 1,

wherein

the refrigerant comprises trans-1,2-difluoroethylene (HFO-1132(E)), trifluoroethylene (HFO-1123), and difluoromethane (R32),

wherein

when the mass % of HFO-1132(E), HFO-1123, and R32 based on their sum in the refrigerant is respectively represented by x, y, and z, coordinates (x,y,z) in a ternary composition diagram in which the sum of HFO-1132(E), HFO-1123, and R32 is 100 mass % are within the range of a figure surrounded by line segments MN, NR, RG, and GM that connect the following 4 points:

point M (47.1, 52.9, 0.0),

point N (38.5, 52.1, 9.5),

point R (23.1, 67.4, 9.5), and

point G (38.5, 61.5, 0.0),

or on these line segments (excluding the points on the line segment GM);

the line segment MN is represented by coordinates $(0.0083z^2 - 0.984z + 47.1, -0.0083z^2 - 0.016z + 52.9, z)$,

the line segment RG is represented by coordinates $(-0.0491z^2 - 1.1544z + 38.5, 0.0491z^2 + 0.1544z + 61.5, z)$, and the line segments JR and GI are straight lines.

24. The refrigeration cycle apparatus according to claim 1,

wherein

the refrigerant comprises trans-1,2-difluoroethylene (HFO-1132(E)), trifluoroethylene (HFO-1123), and difluoromethane (R32),

wherein

when the mass % of HFO-1132(E), HFO-1123, and R32 based on their sum in the refrigerant is respectively represented by x, y, and z, coordinates (x,y,z) in a ternary composition diagram in which the sum of HFO-1132(E), HFO-1123, and R32 is 100 mass % are within the range of a figure surrounded by line segments PS, ST, and TP that connect the following 3 points:

point P (31.8, 49.8, 18.4),

point S (25.4, 56.2, 18.4), and

point T (34.8, 51.0, 14.2),

or on these line segments;

the line segment ST is represented by coordinates $(-0.0982z^2 + 0.9622z + 40.931, 0.0982z^2 - 1.9622z + 59.069, z)$,

the line segment TP is represented by coordinates $(0.0083z^2 - 0.984z + 47.1, -0.0083z^2 - 0.016z + 52.9, z)$, and the line segment PS is a straight line.

25. The refrigeration cycle apparatus according to claim 1,

wherein

the refrigerant comprises trans-1,2-difluoroethylene (HFO-1132(E)), trifluoroethylene (HFO-1123), and difluoromethane (R32),

wherein

when the mass % of HFO-1132(E), HFO-1123, and R32 based on their sum in the refrigerant is respectively represented by x, y, and z, coordinates (x,y,z) in a ternary composition diagram in which the sum of HFO-1132(E), HFO-1123, and R32 is 100 mass % are

within the range of a figure surrounded by line segments QB", B"D, DU, and UQ that connect the following 4 points:

point Q (28.6, 34.4, 37.0),

point B" (0.0, 63.0, 37.0),

point D (0.0, 67.0, 33.0), and

point U (28.7, 41.2, 30.1),

or on these line segments (excluding the points on the line segment B"D);

the line segment DU is represented by coordinates $(-3.4962z^2 + 210.71z - 3146.1, 3.4962z^2 - 211.71z + 3246.1, z)$,

the line segment UQ is represented by coordinates $(0.0135z^2 - 0.9181z + 44.133, -0.0135z^2 - 0.0819z + 55.867, z)$, and

the line segments QB" and B"D are straight lines.

26. A method of determining a refrigerant enclosure amount in a refrigeration cycle apparatus, comprising:

for a refrigeration cycle apparatus including a heat source unit including a compressor and a heat-source-side heat exchanger, a service unit including a service-side heat exchanger, and a refrigerant pipe that connects the heat source unit and the service unit to each other, and for a refrigerant containing at least 1,2-difluoroethylene being enclosed in a refrigerant circuit that is constituted by connecting the compressor, the heat-source-side heat exchanger, and the service-side heat exchanger to one another, setting an enclosure amount of the refrigerant in the refrigerant circuit per 1 kW of refrigeration capacity to 160 g or more and 560 g or less; and

for a refrigeration cycle apparatus including a heat source unit including a compressor and a heat-source-side heat exchanger, a first service unit including a first service-side heat exchanger, a second service unit including a second service-side heat exchanger, and a refrigerant pipe that connects the heat source unit, the first service unit, and the second service unit to one another, and for a refrigerant containing at least 1,2-difluoroethylene being enclosed in a refrigerant circuit that is constituted by connecting the first service-side heat exchanger and the second service-side heat exchanger in parallel to the compressor and the heat-source-side heat exchanger, setting an enclosure amount of the refrigerant in the refrigerant circuit per 1 kW of refrigeration capacity to 190 g or more and 1660 g or less.

* * * * *