



US00D798906S

(12) **United States Design Patent**  
**Bennett et al.**

(10) **Patent No.:** **US D798,906 S**  
(45) **Date of Patent:** **\*\* Oct. 3, 2017**

- (54) **VEHICLE DIFFERENTIAL COVER**
- (71) Applicant: **Omix-Ada, Inc.**, Suwanee, GA (US)
- (72) Inventors: **Patrick W. Bennett**, Gainesville, GA (US); **Christopher D. Van Buren**, Snellville, GA (US)
- (73) Assignee: **Omix-ADA, Inc.**, Suwanee, GA (US)
- (\*\*) Term: **15 Years**
- (21) Appl. No.: **29/544,307**
- (22) Filed: **Nov. 2, 2015**
- (51) **LOC (10) Cl.** ..... **15-01**
- (52) **U.S. Cl.**  
USPC ..... **D15/5**
- (58) **Field of Classification Search**  
USPC ..... D15/1-6, 9, 7, 148, 149  
CPC .... F16H 48/00; F16H 48/38; F16H 2048/382;  
F16H 48/40; F16H 2048/387; F16H  
48/22; F16H 48/08; F16H 48/32  
See application file for complete search history.

D600,167 S	9/2009	Maguire et al.	
D631,799 S	2/2011	Maguire et al.	
8,109,174 B2	2/2012	Hilker et al.	
8,657,716 B1	2/2014	Whyte et al.	
8,684,876 B2	4/2014	Corless et al.	
D717,216 S	11/2014	Dunn et al.	
D741,913 S	10/2015	Besemer et al.	
D743,306 S	11/2015	Clouss	
2003/0110885 A1*	6/2003	Beutler .....	B60K 17/16 74/606 R
2005/0126749 A1*	6/2005	Matti .....	F16H 57/0412 165/41
2006/0054411 A1*	3/2006	Fett .....	F16H 57/0412 184/6.22
2006/0103232 A1*	5/2006	Beutler .....	B03C 1/286 301/137
2008/0020888 A1*	1/2008	Kearney .....	F16C 25/06 475/231

(Continued)

*Primary Examiner* — T. Chase Nelson  
*Assistant Examiner* — Ania Aman  
(74) *Attorney, Agent, or Firm* — Womble Carlyle Sandridge & Rice LLP

(57) **CLAIM**

The ornamental design for a vehicle differential cover, as shown and described.

(56) **References Cited**

U.S. PATENT DOCUMENTS

3,153,464 A *	10/1964	Nelson .....	B60K 17/16 184/11.2
D220,541 S *	4/1971	Liddiard .....	D15/148
4,261,219 A	4/1981	Suzuki et al.	
4,625,581 A	12/1986	Hull	
D327,280 S	6/1992	Macomber	
D345,127 S	3/1994	Stenglein et al.	
5,476,582 A *	12/1995	Camping .....	B01D 35/06 210/167.03
D424,988 S	5/2000	Rothlisberger	
6,675,676 B2	1/2004	Beutler	
6,796,404 B1	9/2004	Dick et al.	
7,004,879 B2	2/2006	Beutler	
7,241,246 B2	7/2007	Beutler	

**DESCRIPTION**

FIG. 1 is a perspective view of a vehicle differential cover showing our new design.  
FIG. 2 is a front elevation view thereof.  
FIG. 3 is a top plan view thereof.  
FIG. 4 is a bottom plan view thereof.  
FIG. 5 is a rear elevation view thereof.  
FIG. 6 is a right side elevation view thereof; and,  
FIG. 7 is a left side elevation view thereof.  
The broken lines illustrate portions of the vehicle differential covers that form no part of the claimed design.

**1 Claim, 5 Drawing Sheets**

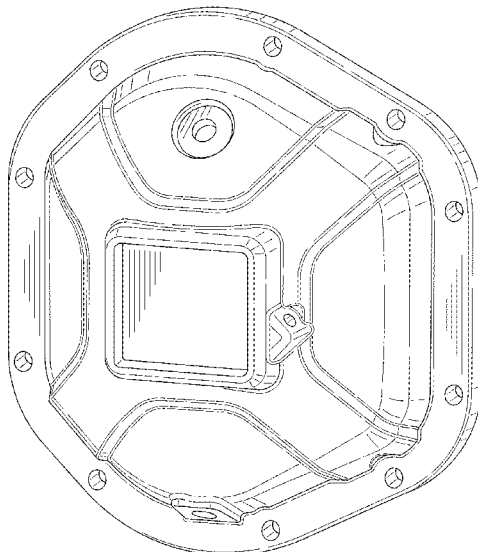

(56)

**References Cited**

U.S. PATENT DOCUMENTS

2009/0023531	A1*	1/2009	Hilker .....	F16H 57/0483 475/160
2009/0071287	A1	3/2009	Paskowitz	
2010/0043581	A1*	2/2010	Kincaid .....	F16H 57/027 74/424
2011/0082001	A1*	4/2011	Beutler .....	F16H 57/037 475/161
2011/0179904	A1*	7/2011	Harnden .....	F16H 57/0483 74/607
2011/0212805	A1*	9/2011	Hilker .....	F16H 57/0483 475/160
2015/0292611	A1*	10/2015	Miyamoto .....	F16H 48/24 475/84
2016/0084365	A1*	3/2016	Besemer .....	F16H 48/22 475/86

\* cited by examiner

FIG 1

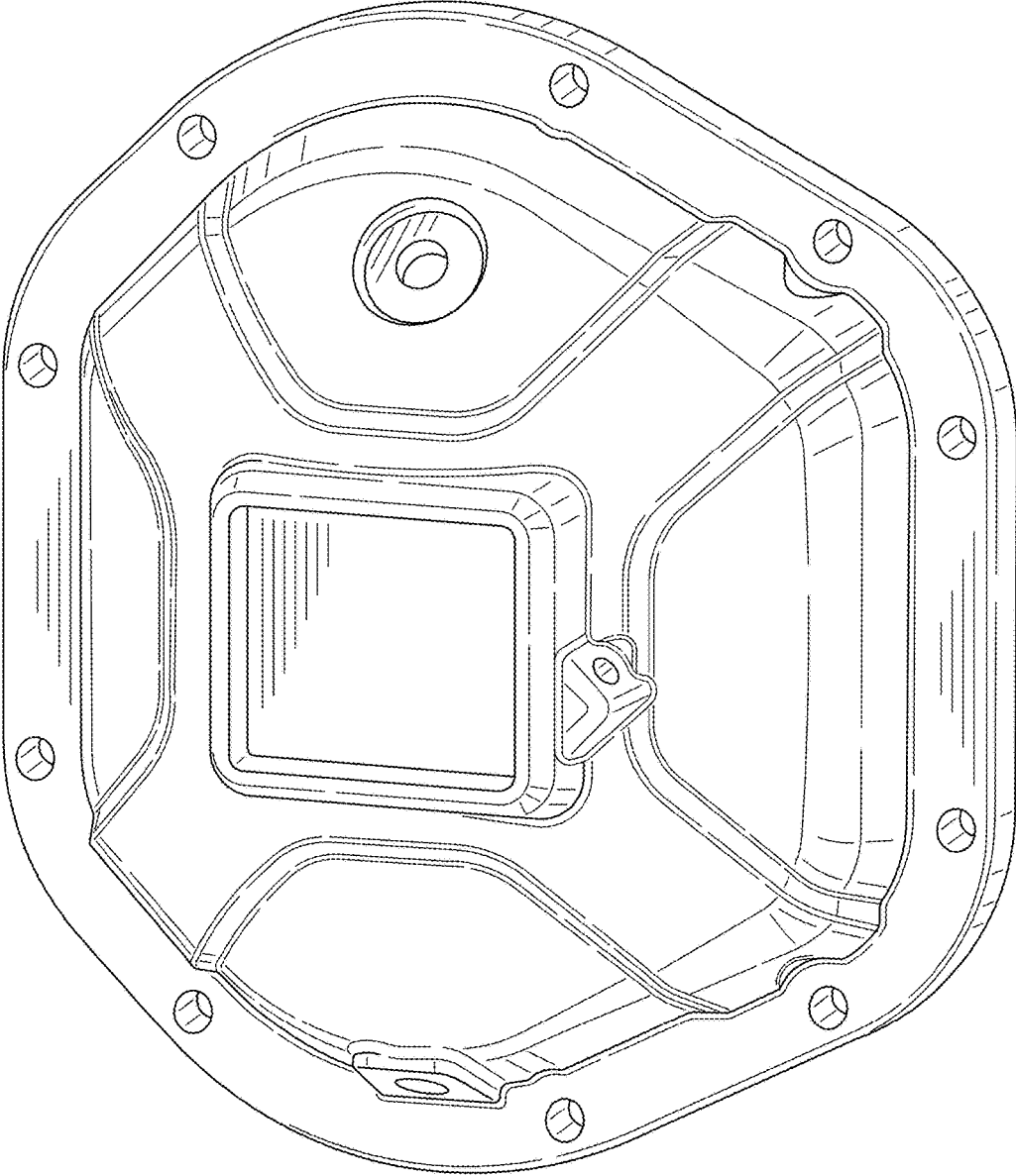

FIG 2

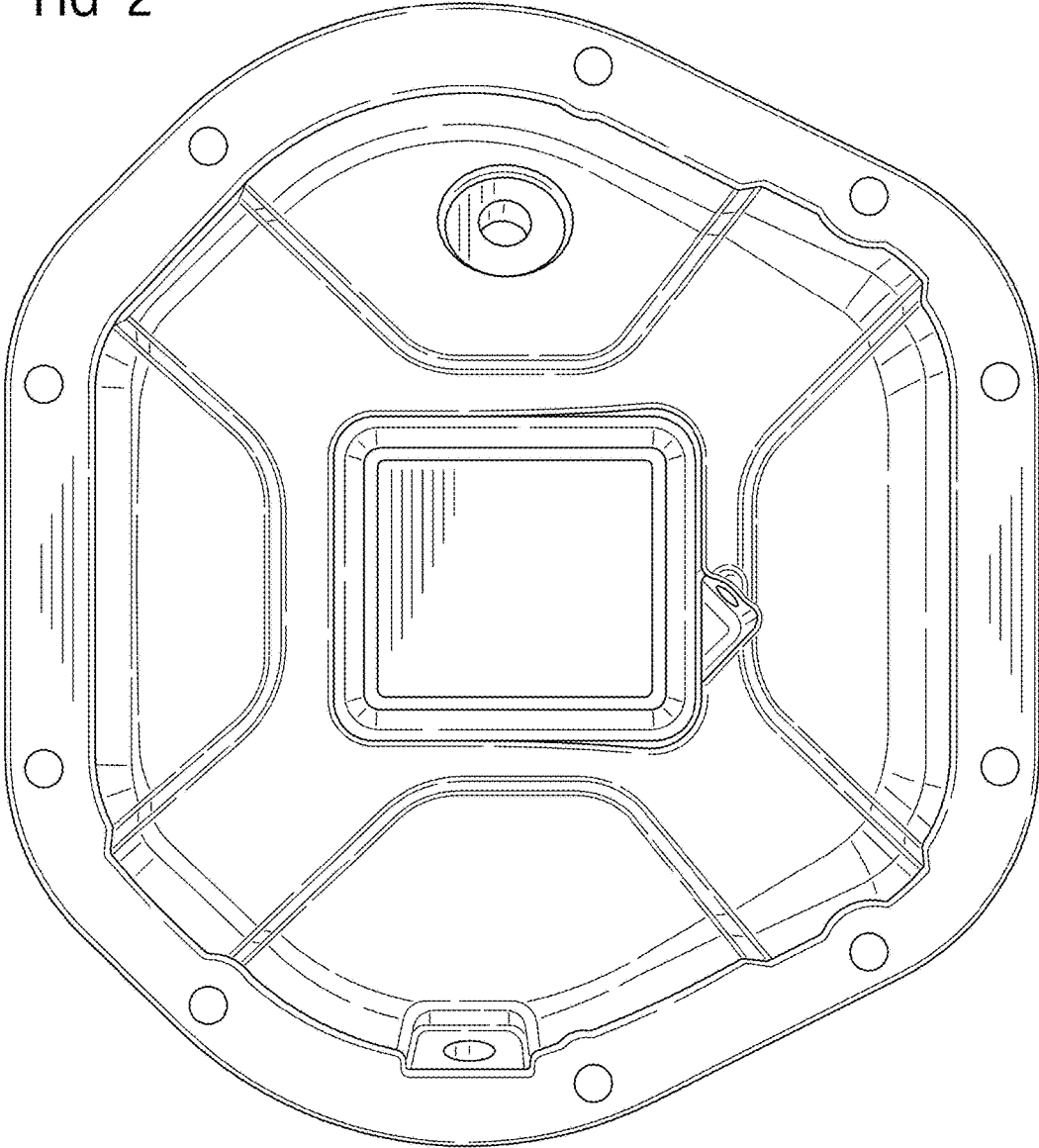

FIG 3

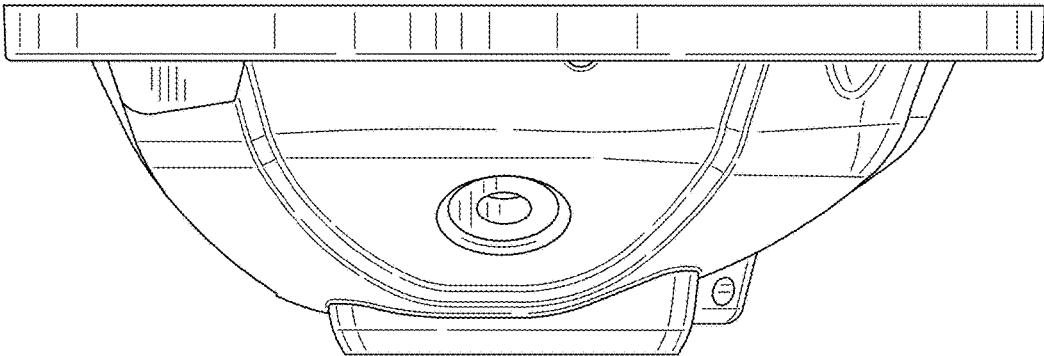

FIG 4

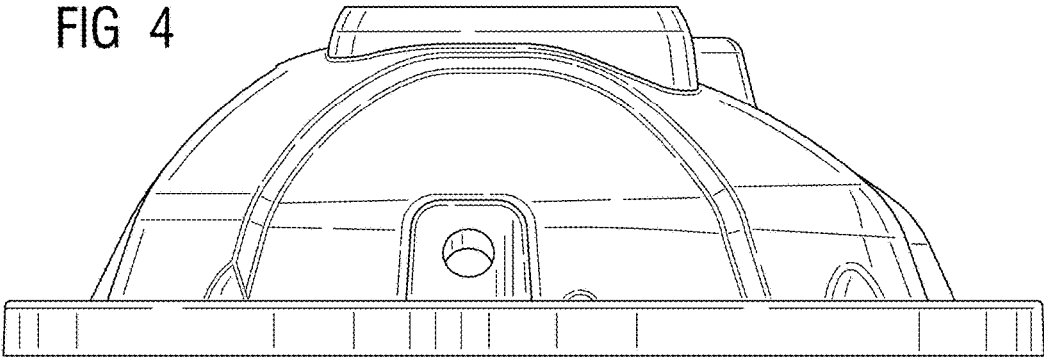

FIG 5

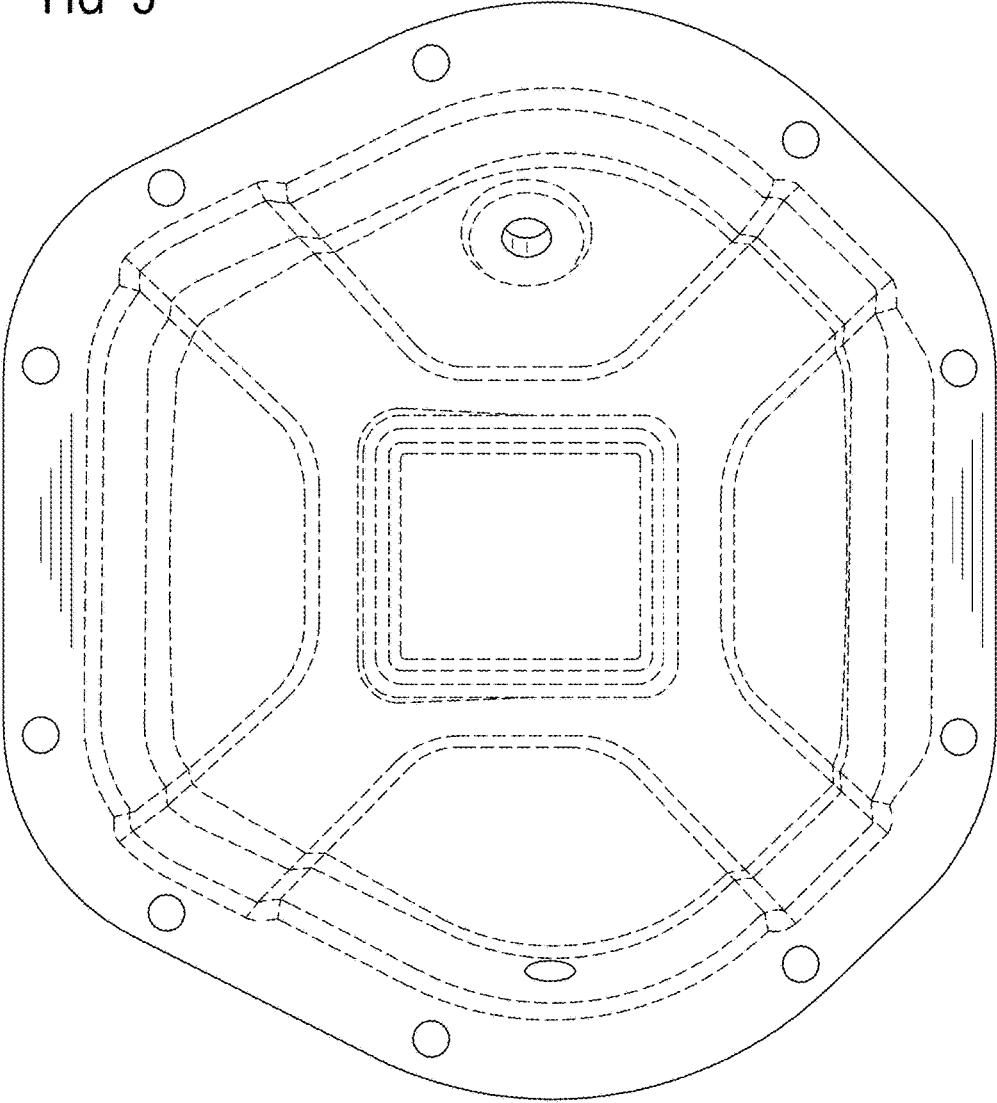

FIG 6

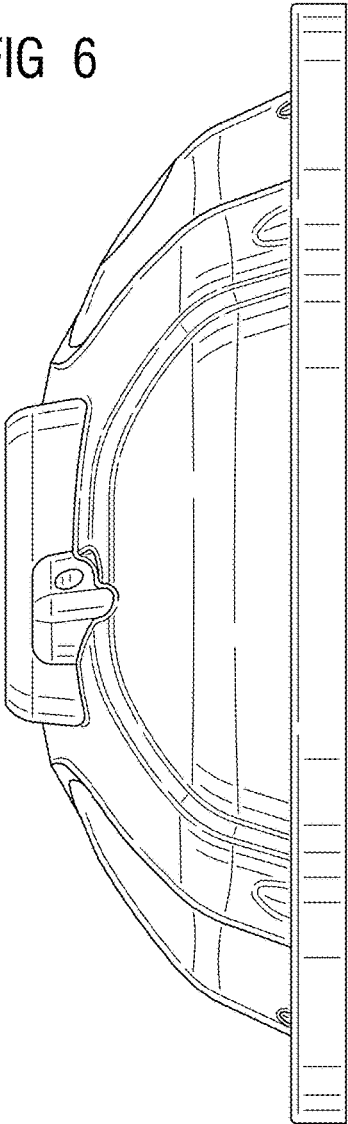

FIG 7

