



(19) **United States**

(12) **Patent Application Publication**
Svensson et al.

(10) **Pub. No.: US 2002/0017764 A1**

(43) **Pub. Date: Feb. 14, 2002**

(54) **FLEXING BASE SKATE**

Publication Classification

(75) Inventors: **John E. Svensson**, Vashon, WA (US);
Antonin A. Meibock, Alberta (CA)

(51) **Int. Cl.⁷** **A63C 17/02**
(52) **U.S. Cl.** **280/11.224; 280/11.221**

Correspondence Address:

CHRISTENSEN, O'CONNOR, JOHNSON,
KINDNESS, PLLC
1420 FIFTH AVENUE
SUITE 2800
SEATTLE, WA 98101-2347 (US)

(57) **ABSTRACT**

A first embodiment of a flexing base skate (10) includes an upper shoe portion (12) mounted on a base (14). The base includes a forefoot region (20) secured to a forward frame segment (26) carrying forward wheels (18a, 18b). A heel region (24) of the base is secured to a rearward frame segment (28) that carries rearward wheels (18c, 18d). The base defines and flexes at a reduced thickness metatarsal head portion (22), with the skater's heel and the rearward frame segment elevating freely relative to the forward frame segment. A spring (72) incorporated into the base biases the skate to the unflexed configuration. The forward frame section overlaps the rearward frame section for lateral stability. An alternate embodiment provides a rigid full length frame (112) and a flexible base (104) mounted only at the forefoot region (106) to the frame. The base (104) flexes at a metatarsal head portion (108), and is constructed to form an integral spring biasing the base against the frame. The base includes a guide (118) for lateral alignment of the heel region (110) with the frame.

(73) Assignee: **K-2 Corporation**

(21) Appl. No.: **09/978,533**

(22) Filed: **Oct. 15, 2001**

Related U.S. Application Data

(60) Continuation of application No. 09/589,864, filed on Jun. 8, 2000, which is a division of application No. 09/094,425, filed on Jun. 9, 1998, now Pat. No. 6,120,040, which is a continuation-in-part of application No. 08/957,436, filed on Oct. 24, 1997, now Pat. No. 6,082,744.

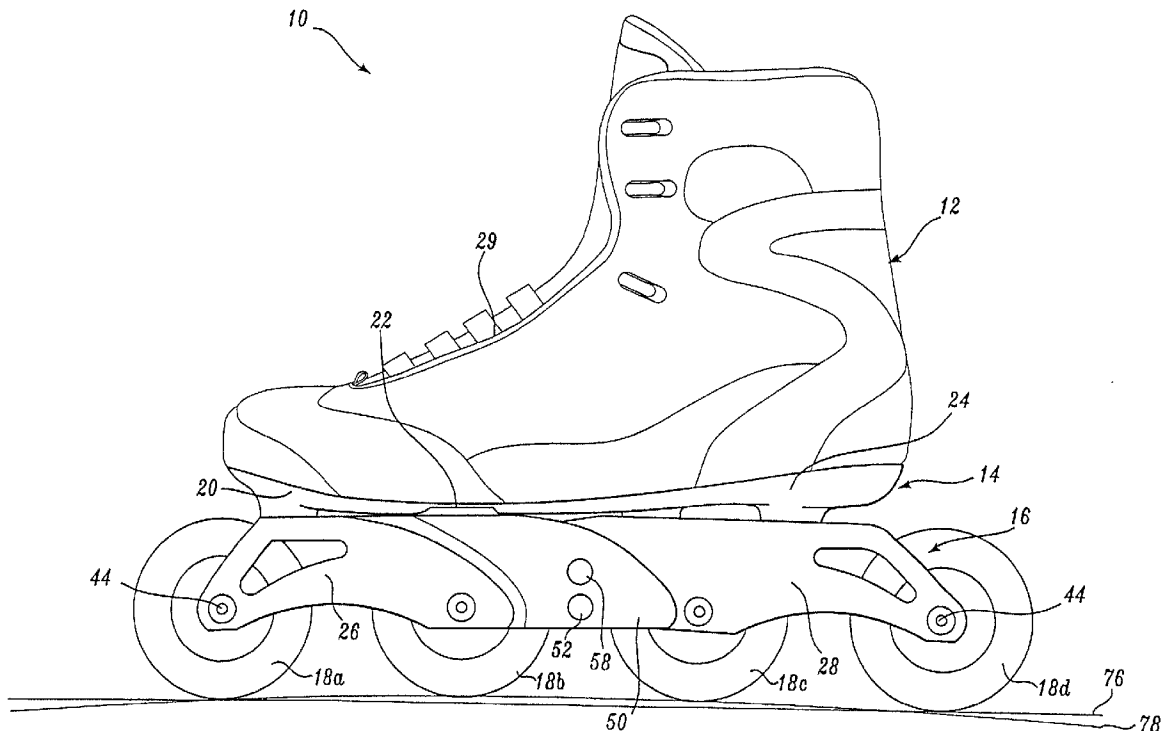

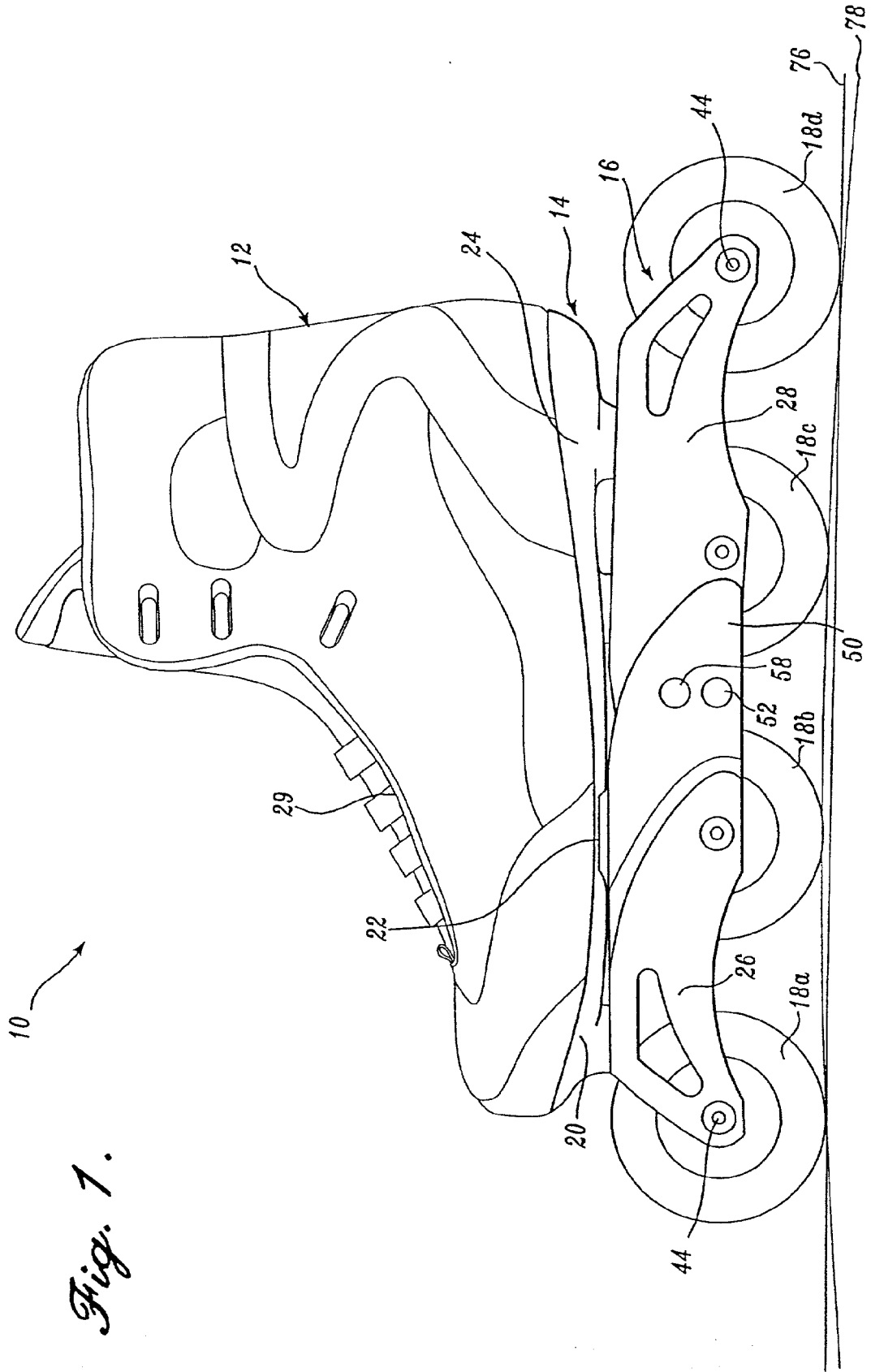

Fig. 1.

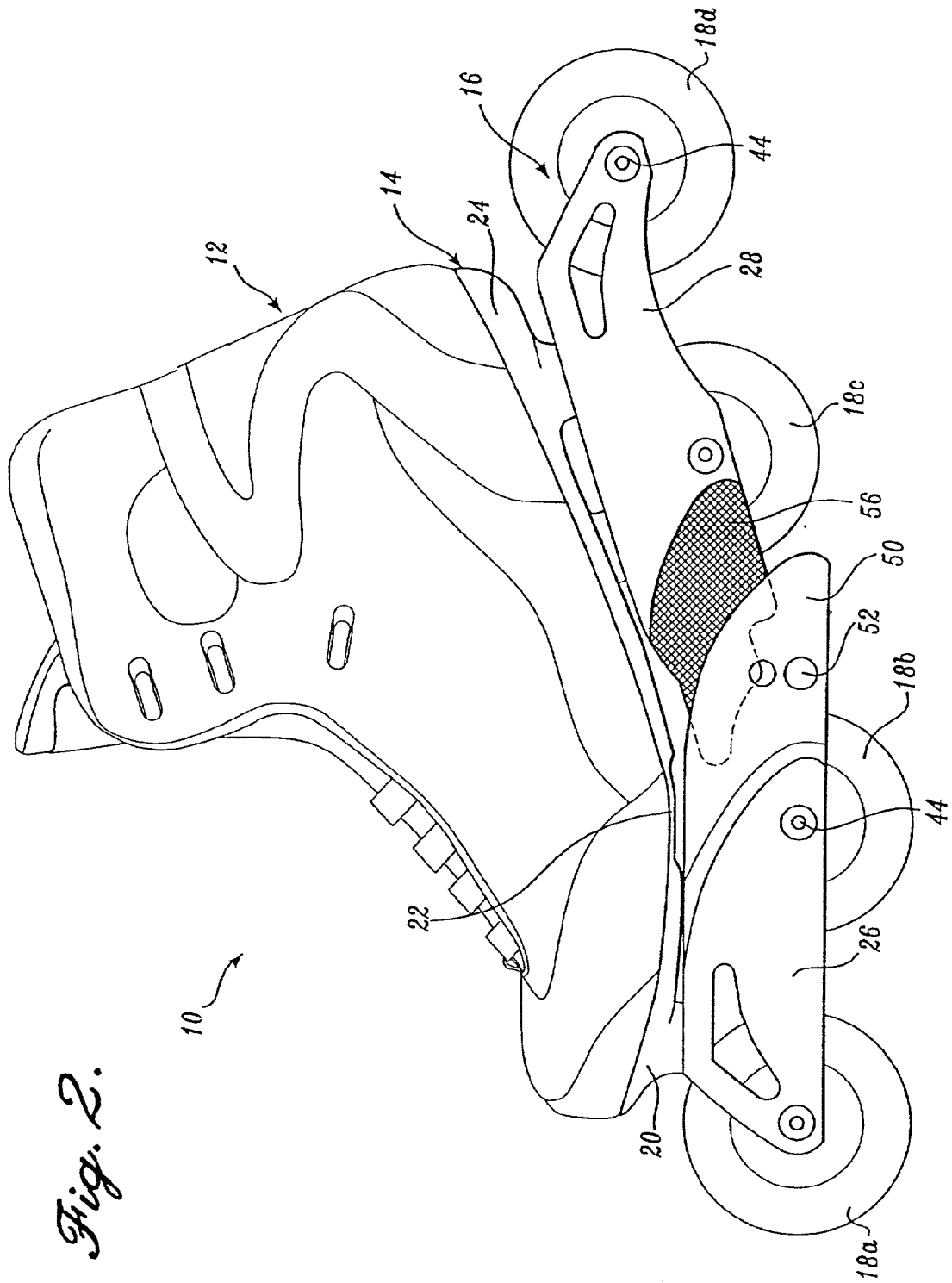

Fig. 2.

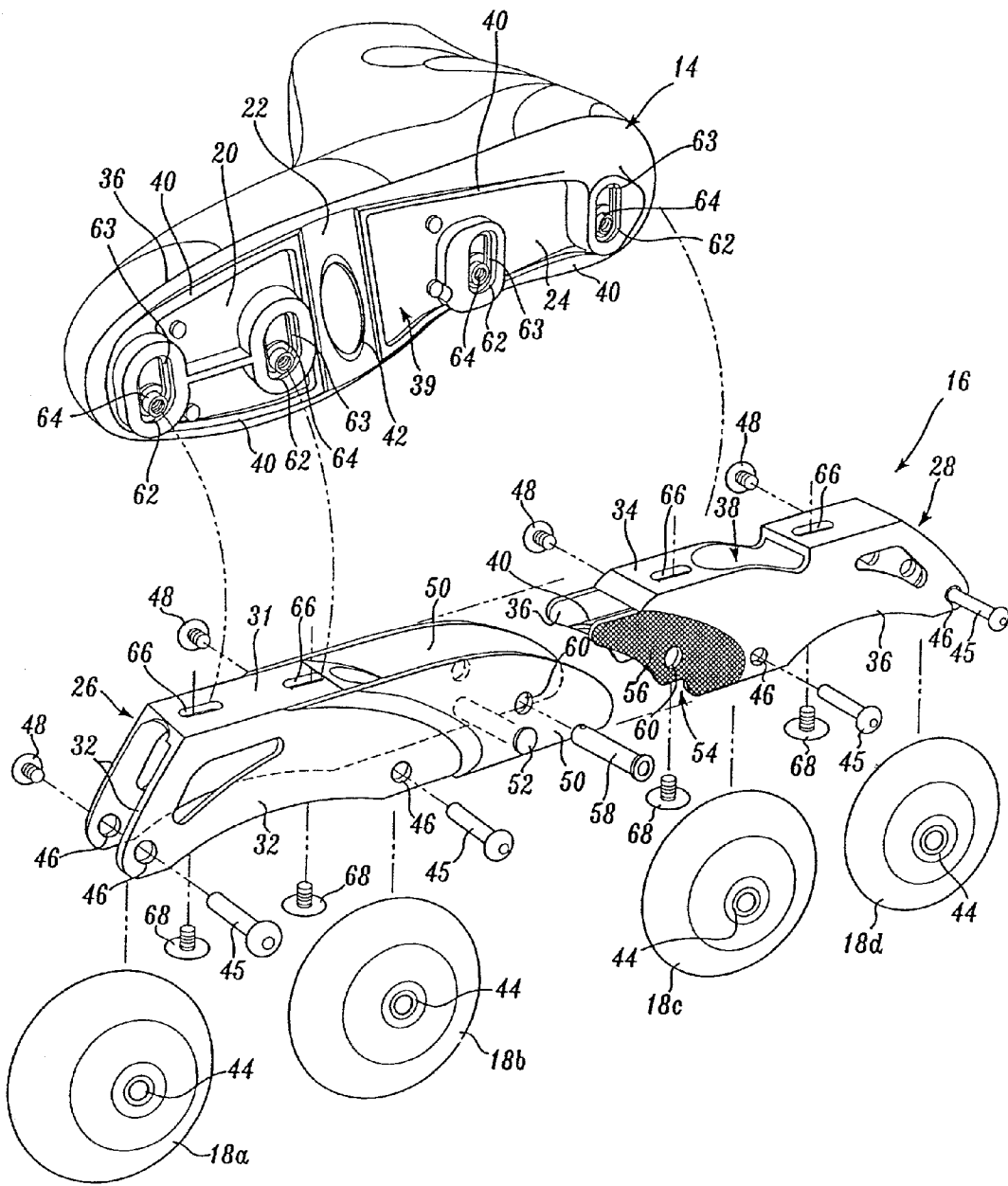

Fig. 3.

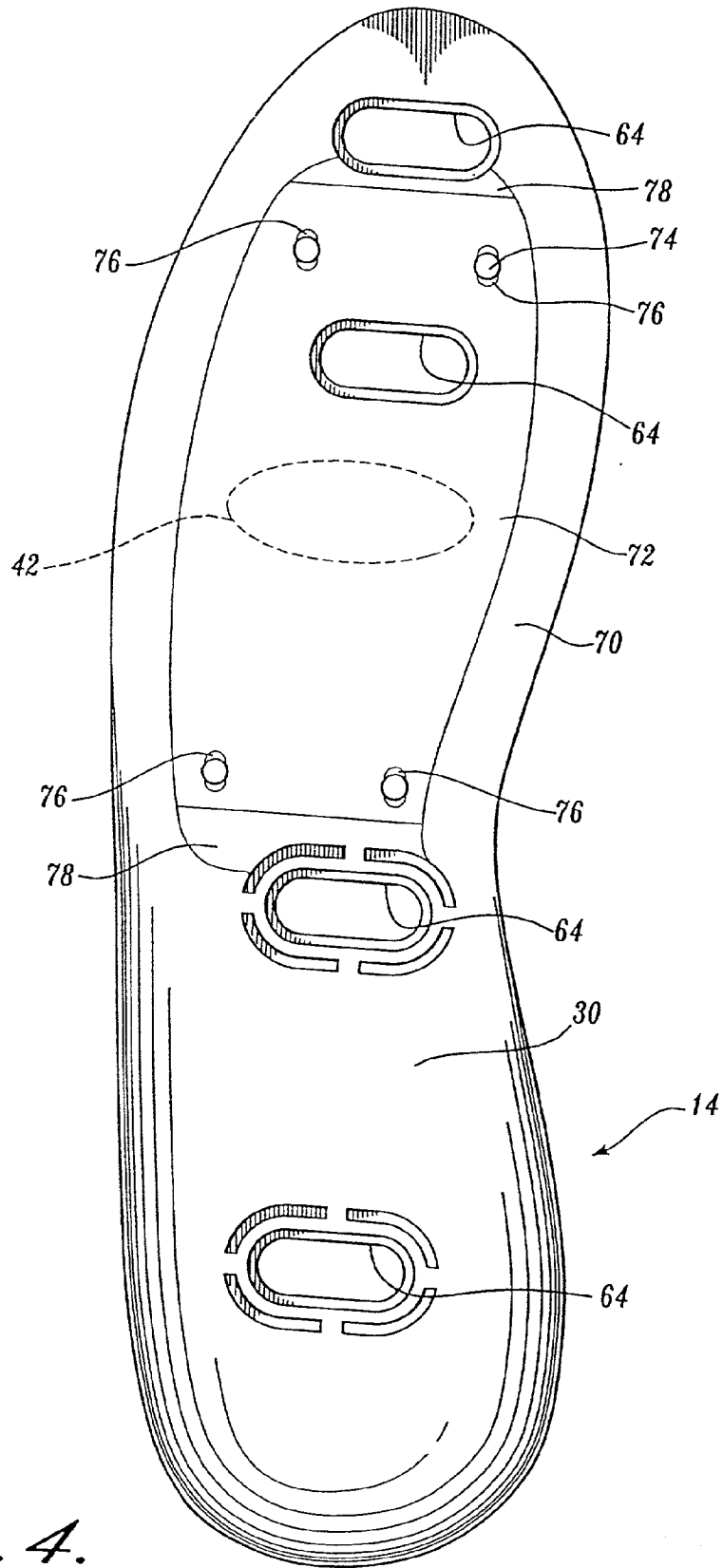

Fig. 4.

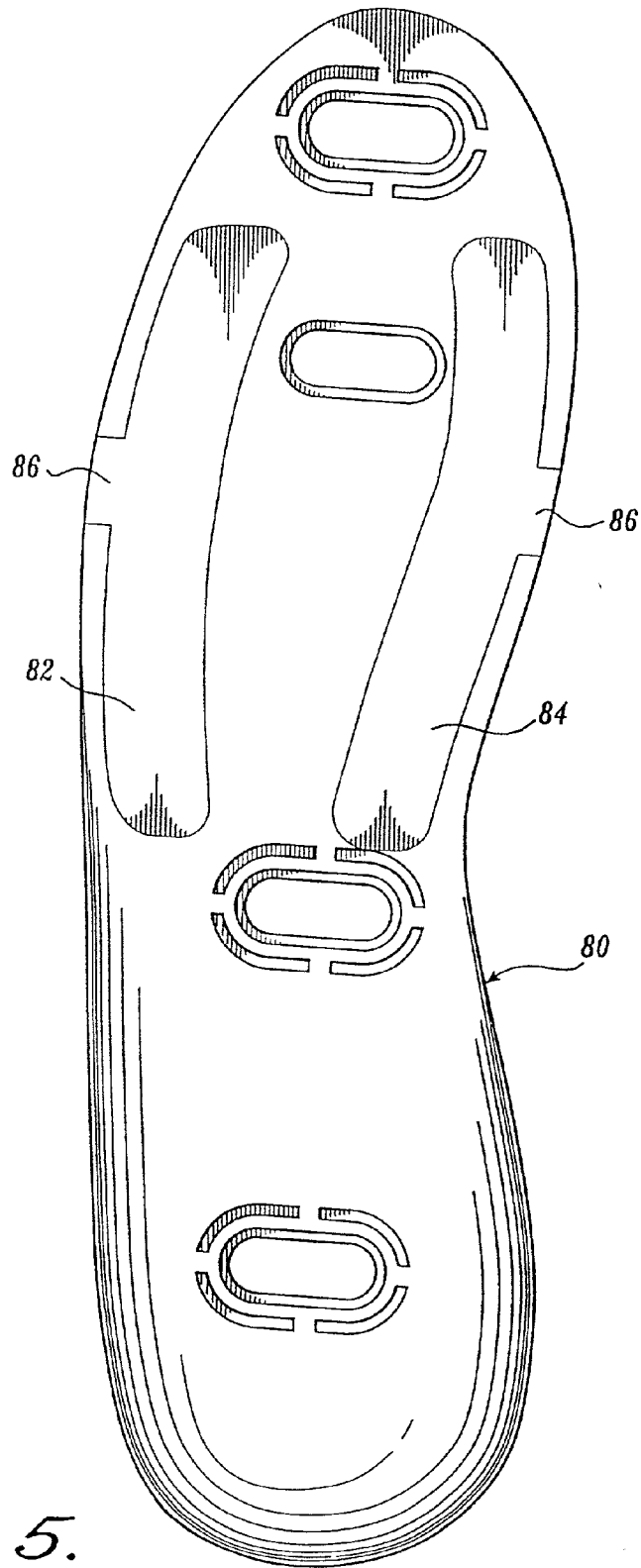

Fig. 5.

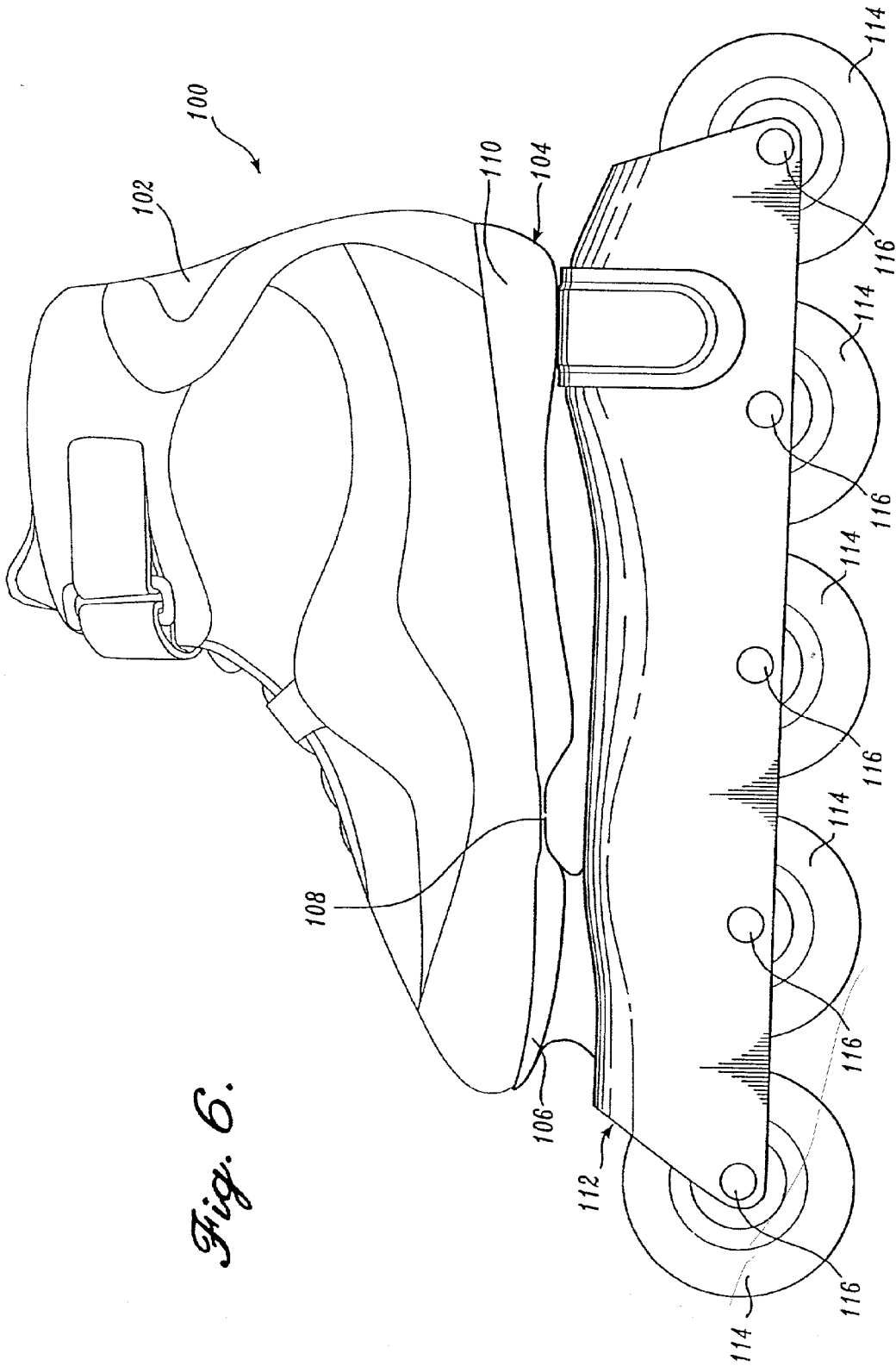

Fig. 6.

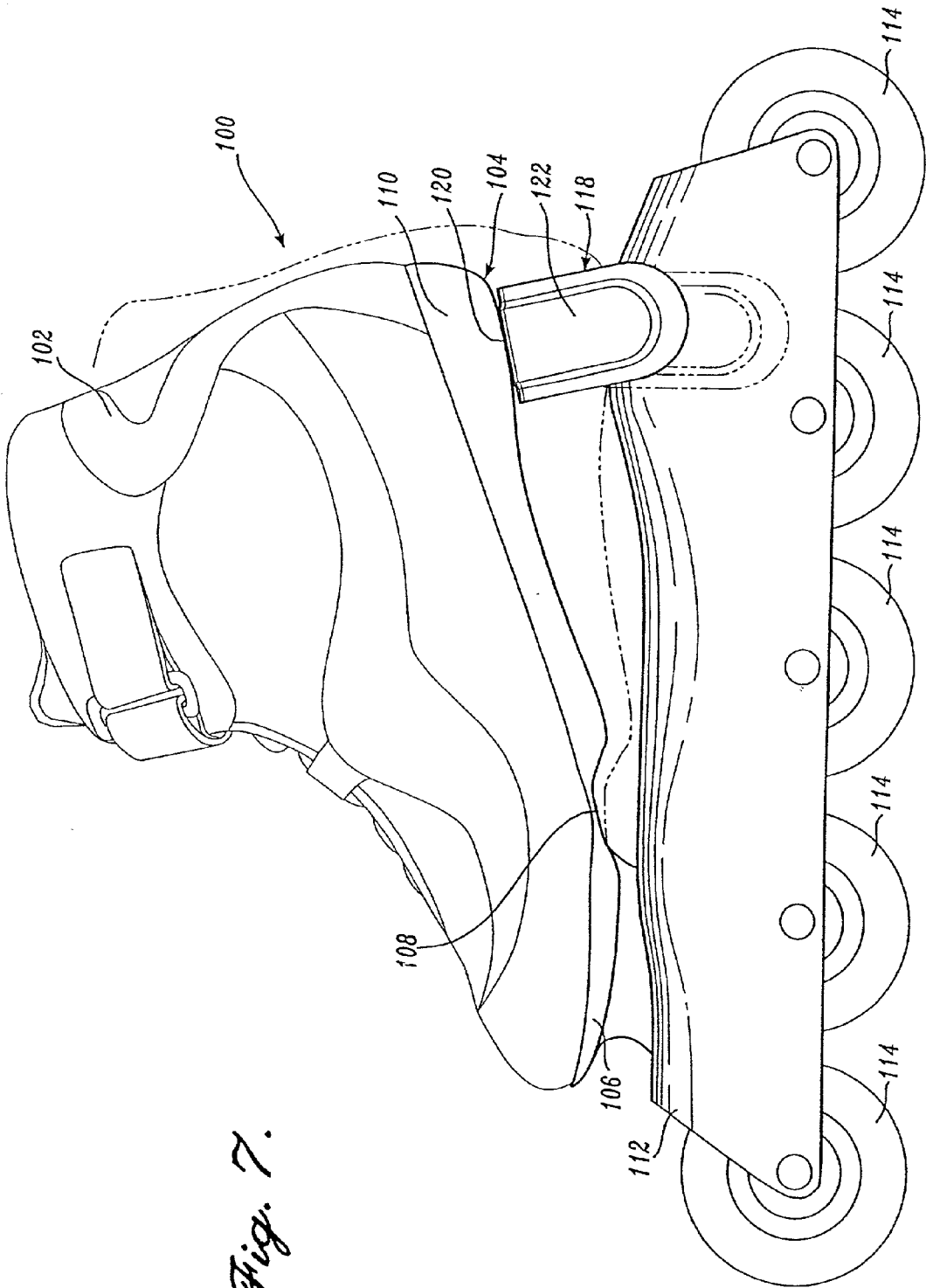

Fig. 7.

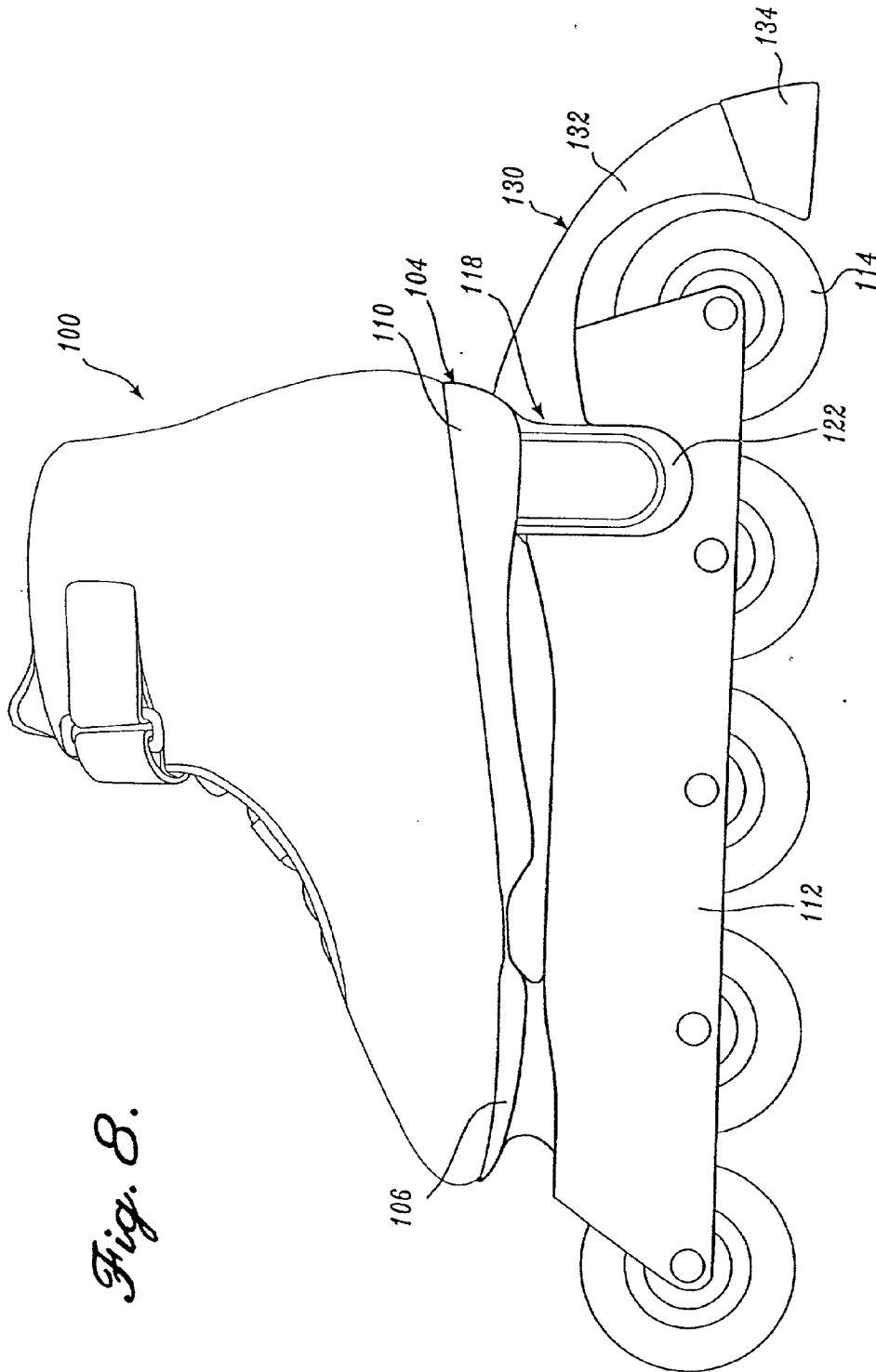

Fig. 8.

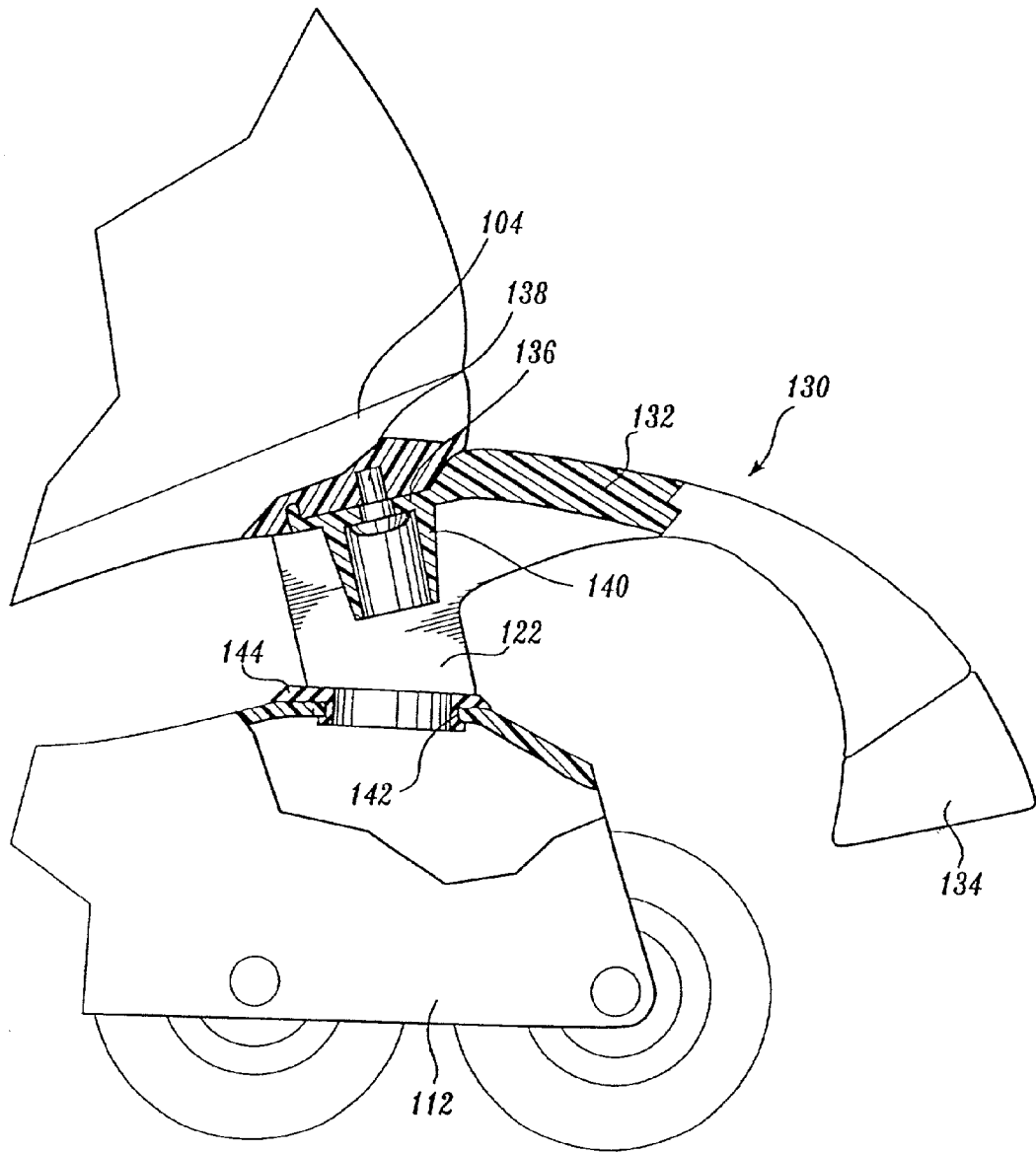

Fig. 9.

FLEXING BASE SKATE

CROSS REFERENCE TO RELATED APPLICATION

[0001] The present application is a continuation-in-part of co-pending U.S. application Ser. No. 08/957,436 filed Oct. 24, 1997, priority of the filing date of which is hereby claimed under 35 U.S.C. § 120.

FIELD OF THE INVENTION

[0002] The present invention relates to roller skates, and more particularly to in-line roller skates with flexible bases.

BACKGROUND OF THE INVENTION

[0003] Conventional in-line roller skates include an upper boot secured to or integrally formed with a rigid or semi-rigid base. The base in turn is secured along its length, including at heel and toe ends, to a rigid frame. A plurality of wheels are journaled along a common longitudinal axis between the sidewalls of the frame. During use the skater alternately strokes on the left and right skates, thrusting off of one skate while gliding on the opposing skate. The ability to fully complete a thrust and thereby achieve maximum forward momentum is limited, however, because of the rigid frame being secured to the heel and toe of the skater's foot.

[0004] Because of the rigid, inflexible securement of the frame and base of such skates, a skater attempting to achieve optimal speed during skating may adopt a skating stroke that does not entail plantarflexion of his or her ankle during the push-off phase of the stroke. The term "plantarflex" refers to the rotation of the foot relative to the leg within a plane defined by the leg, where the forefoot moves distally relative to the leg. By avoiding plantarflexion at the ankle, all skate wheels remain on the ground, with the skate base and frame parallel to the ground. The skate thus does not pivot significantly on the forwardmost wheel. Alternately, a skater may adopt a stroke style entailing plantarflexion of his or her ankle during the skate stroke, allowing the forefoot to move distally of the leg, thereby allowing the calf muscles to generate more power during the skate stroke. Due to the rigid nature of the frame and base however, this causes the skater's ankle to elevate excessively off the ground, and may be uncomfortable for the skater. This also entails excessive movement of the skater's upper body and legs, and entails excess wear of the front wheel.

[0005] In-line skates with wheels supported on first and second separate frame sections, secured beneath the toe and heel of the skate, such that the foot can flex during the skating stroke, have been proposed. For example, U.S. Pat. No. 5,634,648 discloses a skate including a boot having a rigid toe portion pivotally coupled at the lateral sides of the foot to a rigid heel portion. A first frame segment supporting two wheels is secured beneath the toe section, and a second frame segment supporting two additional wheels is secured beneath the heel section. A tab extends rearwardly from the base of the toe section and is received within a corresponding slot formed in the base of the heel section. During use the skater is able to flex the foot at the sidewall pivot point of the upper, with the tab flexing along its length, so that the heel and rear frame section can elevate off of the ground. While permitting flexion of the foot, flexion is not centralized or primarily occurring at the metatarsal head of the

skater's foot, as is anatomically preferred. Thus flexing may be uncomfortable. Additionally, because the boot flexes rearwardly of the front frame and wheels, an unstable platform is provided by the forward segment of the frame during thrusting with the heel elevated. Further, because the two frame segments are separated and uncoupled at all times, there is no lateral rigidity of the frame, even when both frame sections are on the ground. Thus, except to the limited extent provided by the pivot joints between the heel and toe sections of the upper and the forward to rearward tab, there is no torsional rigidity of the skate, as would be desired for straight tracking of the skate.

[0006] An alternate flexing skate has been proposed in European patent application EP 0 778 058 A2. A skate is disclosed having an upper boot with a separate toe segment that is slidably received within the forward end of a rear boot segment, and which is pivotally joined to the rear boot segment immediately below the base of the skate. Forward and rearward frame sections are secured beneath the forward and rearward segments of the boot. The rear ends of the sidewalls of the forward frame section overlap the forward ends of the sidewalls of the rear frame section. A second pivot pin is secured through aligned apertures in the forward frame section sidewalls and through corresponding slots in the overlapped sidewalls of the rear frame section. During use the boot pivots to allow the foot to flex during thrusting, with the slotted rearward frame section moving on the second pivot pin retained by the forward frame section. Thus, a limited degree of flexure is provided, with the pivotal coupling of the frame segments also providing a degree of lateral stability and torsional stiffness.

[0007] The degree of flexion of such a skate disclosed in the European '058 application is limited, however, by the relatively short length of the slots formed in the rearward frame section. Further, the upper or lower positioning of the rear end of the skate is controlled solely by force applied by the user's foot and leg. During the portion of the skating stroke where the user would desire the wheels to be commonly aligned on the ground in a flat line, the rear of the skate may thus undesirably bump upwardly and downwardly. An alternate embodiment of a skate disclosed in the same European '058 application has a rigid full-length frame and an unsecured rear boot portion which can be lifted off of the frame for flexure during the stroke. However, there is no provision for laterally stabilizing the heel of the boot relative to the frame, such that undesired torsional or lateral movement of the boot relative to the frame may be encountered. Additionally, as in the segmented frame embodiment, the heel may lift undesirably from the frame at inappropriate times.

SUMMARY OF THE INVENTION

[0008] The present invention provides a roller skate having a shoe portion for receiving a skater's foot and a base having an upper surface securable to an underside of the shoe portion for supporting the received skater's foot. The base includes a heel region and a forefoot region, the forefoot region having a metatarsal head portion. A frame is secured to an underside of the base at least below the forefoot region of the base such that the base can flex intermediate of the forefoot region and heel region during skating to permit elevation of the skater's heel. The frame extends below the base and rotatably receives a plurality of

wheels. At least one forward wheel is disposed below the forefoot region of the base, and at least one rearward wheel is disposed below the heel region of the base. The metatarsal head portion of the base defines a stress concentrating contour that focuses flexure of the base at the metatarsal head portion.

[0009] In a further aspect of the present invention, the skate includes a biasing member coupled to the base to bias the heel region of the base to a lower position, in which the heel region of the base bears on the frame, the rearward wheel and the ground. The biasing member preferably exerts a downward preload on the heel region of the base when the heel region is in the lower position.

[0010] In a first preferred embodiment of the present invention, the frame of the skate includes a forward segment secured to an underside of the base below the forefoot region of the base, and a rearward segment secured to the underside of the base below the heel region. The forward segment mounts the at least one forward wheel below the forefoot region of the base, while the rearward segment mounts the at least one rearward wheel below the heel region of the base. One of the forward or rearward frame segments includes first and second stabilizing flanges that extend toward and slidably overlap opposing first and second sides of the other of the forward and rearward frame segments. The forward and rearward frame segments freely slide and pivot relative to each other during flexure of the base.

[0011] In an alternate preferred embodiment to the present invention, the skate includes a frame secured to an underside of the base at the forefoot region of the base. The heel region of the base bears on the frame in a lower position, and elevates away from the frame to an upper position upon flexure of the base during skating. A guide is secured to one of the frame and the heel region of the base and projects toward and slidably engages the other of the frame and the heel region of the base during flexure of the base.

[0012] The present invention thus provides skates having bases that flex, preferably below the metatarsal head of the skater's foot, in conformity with the anatomy of the foot. In a first preferred embodiment, the frame is split into two segments which overlap each other for lateral stability, yet which freely and slidably pivot relative to each other during flexure. In an alternate embodiment, the heel of the shoe portion lifts away from the frame during flexure, and a guide is preferably provided that maintains lateral positioning of the upper relative to the frame during this movement. Thus the skates of the present invention provide for increased thrust during the skating stroke due to the ability to flex the foot, and concentrate flexing at the foot at the point most anatomically desirable and efficient. The preferred embodiments of the present invention include a biasing member, such as a spring plate, that preloads the heel of the skate in the lower position, such that after each stroke during skating the heels snap back downwardly for full engagement with the frame and ground.

BRIEF DESCRIPTION OF THE DRAWINGS

[0013] The foregoing aspects and many of the attendant advantages of this invention will become better understood by reference to the following detailed description, when taken in conjunction with the accompanying drawings, wherein:

[0014] FIG. 1 provides a side view of a skate constructed in accordance with a first preferred embodiment of the present invention, having a flexing base and split frame, with the skate illustrated in the non-flexed and non-loaded configuration;

[0015] FIG. 2 provides a side view of the skate of FIG. 1 with the skate in the flexed configuration;

[0016] FIG. 3 provides an exploded pictorial view of the skate of FIG. 1;

[0017] FIG. 4 provides a top plan view of the base of the skate of FIG. 1;

[0018] FIG. 5 provides a top plan view of an alternate embodiment of the base suitable for incorporation into the skate of FIG. 1 with interchangeable spring elements;

[0019] FIG. 6 provides a side view of a skate constructed in accordance with a second preferred embodiment of the present invention having a rigid frame and flexing base, with the heel end of the base being free of the frame, shown in the unflexed configuration;

[0020] FIG. 7 provides a side view of the skate of FIG. 6 in the flexed configuration;

[0021] FIG. 8 provides a side view of alternate configuration of the skate of FIG. 6 including a brake element mounted on the base of the skate, in the unflexed configuration; and

[0022] FIG. 9 provides a detailed, partial cross-sectional side elevation view of the skate of FIG. 8 in the flexed configuration, with the guide member shown in phantom.

DETAILED DESCRIPTION OF THE PREFERRED EMBODIMENT

[0023] A first preferred embodiment of a flexing base skate 10 constructed in accordance with the present invention is illustrated in FIGS. 1 and 2. The skate 10 includes an upper shoe portion 12 that receives and surrounds a skater's foot and ankle, and which is mounted on and secured to a base 14 that is flexible at least at one point along its length. The base 14 underlies and supports the user's foot. The base 14 is in turn secured to a split frame assembly 16 extending longitudinally beneath the base 14. A plurality of wheels 18a, 18b, 18c and 18d are journaled between first and second opposing longitudinal sidewalls of the frame assembly 16.

[0024] The base 14 includes a forefoot region 20 that underlies and supports the ball and toes of the user's foot. The forefoot region 20 of the base includes a metatarsal head portion 22 that underlies the zone corresponding to the metatarsal head of a skater's foot. The base 14 extends rearwardly, terminating in a heel region 24 underlying the skater's heel. The frame assembly 16 includes a forward frame segment 26 secured to the forefoot region 20 of the base 14, and a rearward frame segment 28 that is secured to the heel region 24 of the base 14. As used herein throughout, "forward" refers to the direction of the forefoot region 20 of the skate, while the term "rearward" refers to the opposing direction of the heel region 24 of the skate.

[0025] The inclusion of a forward frame segment 26 and a rearward frame segment 28, and the formation of the base 14 to permit flexure intermediate of the forward and rear-

ward ends of the base 14, permits the skater's foot and the upper shoe portion 12 to flex during the skating stroke. The base 14 and upper shoe portion 12 flex from a lower position, illustrated in FIG. 1 in which the front and rear frame segments 26, 28 are longitudinally aligned, and a flexed, upper position illustrated in FIG. 2, in which the heel region 24 of the base 14 and rearward frame segment 28 pivot upwardly relative to the forefoot region 20 of the base 14 and forward frame segment 26. Each of the components of the skate 10 will now be described in greater detail.

[0026] Referring to FIGS. 1 and 2, the upper shoe portion 12 is of conventional construction, surrounding the toes, sides, heels and ankle of a user's foot. The upper shoe portion 12 includes a vamp 29, a tongue and a closure such as a lace system. The upper shoe portion 12 illustrated is supported by a rigid or semi-rigid internal heel cup and ankle cuff (not shown), which helps vertically stabilize the skate. Other conventional upper shoe portion constructions are also within the scope of the present invention, including flexible uppers reinforced by external ankle cuffs and heel cups. The upper shoe portion 12 is constructed at least partially from flexible materials so that the upper shoe portion 12 will flex together with the base 14.

[0027] The base 14 is best viewed in FIGS. 1, 3 and 4. The base 14 has an upper surface 30 (FIG. 4) that receives and supports the undersides of the upper shoe portion 12. The base 14 is secured to the upper shoe portion 12 by any conventional method, including bolting, riveting, stitching and adhesive lasting. While the base 14 is illustrated as separate from the upper shoe portion 12, it should also be understood that the base 14 could be integrally formed with the upper shoe portion 12, so long as the upper shoe portion 12 and base 14 accommodate flexing in the manner to be described further herein. The upper surface 30 of the base 14 is bordered by a raised lip surrounding the perimeter of the base 14. The lip extends upwardly at the rear and forward ends to partially surround the lower edges of the toes and heels of the user.

[0028] As best illustrated in FIGS. 1 and 3, the base 14 includes a lower surface 39 that is supported by longitudinally oriented ribs 40 extending along the inner and outer longitudinal sides of the lower surface 39 of the base 14. The ribs 40, formed as increased thickness sections of the base 14, serve to rigidize the heel region 24 and a forward portion of the forefoot region 20 of the base 14. However, the ribs 40 do not extend longitudinally below the metatarsal head portion 22 of the forefoot region 20 of the base. Thus, the effective thickness of the metatarsal portion 22 of the base 14 is reduced relative to the thickness of the surrounding regions of the base 14. This reduced thickness enables the base 14 to flex at the metatarsal head portion 22, and more specifically focuses the flexure of the base 14 at the metatarsal head portion 22, in a gradual arc along the length of the metatarsal head portion, as illustrated in FIG. 2.

[0029] The ability of the metatarsal head portion 22 to flex is further enhanced by the formation of a transverse, elongate aperture 42 through the metatarsal head portion 22. The aperture 42 extends transversally and centrally across approximately half of the width of the metatarsal head portion 22, and also extends forwardly and rearwardly across the majority of the length of the metatarsal head portion 22. This aperture 42 serves to further concentrate the

stress of flexure on the metatarsal head portion 22. Moreover, the aperture 42 is formed with a transverse elongate ovoid configuration, serving to further focus the flexure along the centerline of the metatarsal head portion 22. Thus, as illustrated in FIG. 2, the base 14 and upper shoe portion 12 flex at the anatomically preferred position just below the metatarsal head, following the natural contour of the metatarsal head as it flexes.

[0030] Attention is now directed to FIG. 3 to describe the construction of the split frame assembly 16. Each of the forward frame segment 26 and the rearward frame segment 28 has an independent torsion box construction. The forward frame segment 26 has a top wall 31 extending rearwardly from immediately below a forward toe portion of the forefoot region 20 of the base 14, to just forwardly of the metatarsal head portion 22. The forward frame segment 26 further includes left and right opposing sidewalls 32 that are oriented longitudinally relative to the length of the base 14. The rear frame segment 28 correspondingly includes a top wall 34 and longitudinal left and right sidewalls 36. The top wall 34 runs from beneath an arch portion of the heel region 24 of the base 14, to the rear end of the heel region 24. A weight reducing aperture 38 is cut out from the center of the top wall 34.

[0031] The top walls 31 and 34 of the forward and rearward frame segments 26 and 28 are horizontally oriented, with the sidewalls 32 and 36 projecting perpendicularly downward therefrom. Each frame segment 26, 28 is completed by a series of lower horizontal braces 40 spanning between the left and right sidewalls 32 of the forward frame segment 26 and the left and right sidewalls 36 of the rearward frame segment 28. The lower braces 40 are parallel to and spaced downwardly from the top walls 31 and 34, and are oriented between the wheels 18a, 18b, 18c and 18d.

[0032] Specifically, the forward frame segment 26 carries a first forward wheel 18a and a second forward wheel 18b journaled between the opposing sidewalls 32. Each wheel includes a center hub and bearing assembly 44 that is mounted rotatably on an axle 45 that is inserted through aligned apertures 46 of the sidewalls 32 and is retained by cap screws 48. In the forward segment 26 of the frame, a single horizontal brace 40 (not shown) is disposed between the first forward wheel 18a and the second forward wheel 18b. The rearward frame segment 28 similarly carries a first rearward wheel 18c and a second rearward wheel 18d journaled between its sidewalls 36 on axles 45. A first horizontal brace 40 is formed between the sidewalls 36 just forwardly of the first rearward wheel 18c, and a second horizontal brace (not shown) is formed between the first and second rearward wheels 18c and 18d. The top walls, sidewalls and lower horizontal braces of the forward and rearward segments 26, 28 thus complete for each frame segment a stiff elongate box-like structure having good torsional rigidity. The torsional rigidity provided by the horizontal braces 40 is desirable, but a frame constructed without crossbracing would also be within the scope of the present invention. Likewise, alternate crossbracing, such as diagonal internal crossbracing, or external braces extending down from the base 14 could be utilized. The frame segments 26, 28 can be formed from any suitable rigid material, such as aluminum, titanium, other metals and alloys, engineering thermoplastics, and fiber reinforced thermoplastics or thermosetting polymers.

[0033] Referring still to FIG. 3, the forward frame segment 26 includes left and right stabilizing flanges 50 secured to or integrally formed with the sidewalls 32 to form rearward extensions thereof. The stabilizing flanges 50 extend rearwardly of the innermost, i.e., second forward wheel 18b, towards the innermost, i.e., first rearward wheel 18c. The stabilizing flanges 50 can be welded (for metal materials), screwed, adhered or riveted to the sidewalls 32 of the forward frame segment 26. Alternately, the forward frame segment 26 including the stabilizing flanges 50 can be integrally cast, molded or machined. The stabilizing flanges 50 have an internal spacing separating the two flanges such that they closely and slidably receive the forward ends of the sidewalls 36 of the rearward frame segment 28. In the preferred embodiment, the spacing between the stabilizing flanges 50 of the forward frame segment 26 is greater than the spacing between the remainder of the sidewalls 32 of the forward frame segment 26. Thus the sidewalls effectively expand externally, bending first laterally outward and then rearwardly, to define the stabilizing flanges 50.

[0034] FIG. 1 illustrates the stabilizing flanges 50 overlapping the forward ends of the sidewalls 36 of the rearward frame segment 28. The overlap fit of the stabilizing flanges 50 and sidewalls 36 of the rearward frame segment 28 is close, with the width from the outer surface of the left sidewall 36 to the outer surface of the right sidewall 36 being just slightly less than the width between the inner surfaces of the stabilizing flanges 50. This close fit is desirable so that the rearward frame segment 28 is substantially prevented from pivoting laterally, i.e., off longitudinal axis, relative to the forward frame segment 26. Thus, the stabilizing flanges 50 serve to torsionally couple the independent frame segments 26 and 28, particularly where the base 14 is unflexed as illustrated in FIG. 1. The frame segments 26 and 28 are coupled only by this overlap, and by virtue of both being secured to the base 14, and are preferably otherwise independent. This stabilizing overlap continues at least partially during all stages of flexure of the base 14.

[0035] To further increase the torsional rigidity of the frame assembly 16, the stabilizing flanges 50 are reinforced by a transverse stabilizing pin 52 inserted through aligned apertures formed through lower edge portions of the flanges 50. The stabilizing pin 52 is retained in place by a head on one end, and a cap screw or a flare formed on the other end. The stabilizing pin 52 prevents the stabilizing flanges 50 from undesirably flaring outward or bending away from each other during use, maintaining them in spaced parallel disposition.

[0036] The forward ends of the sidewalls 36 of the rearward frame segment 28 each include a notch-like recess 54 that receives and accommodates the stabilizing pin 52 when the frame segments 26 and 28 are longitudinally aligned in the unflexed configuration, as shown in FIG. 1. This notch 54 allows the stabilizing pin 52 to be set rearwardly as far as possible for maximum transverse stabilization. In the preferred embodiment illustrated in FIG. 3, the rearward ends of the stabilizing flanges 50 taper downwardly in vertical width as they extend rearwardly. Conversely, the forward ends of the sidewalls 36 taper forwardly and upwardly in vertical width as they extend forwardly. This construction allows for maximum overlapping of the stabilizing flanges 50 and sidewalls 36. However, other configurations, including blunt ends on both the stabilizing flanges

50 and sidewalls 36, are possible. Further, rather than including distinct stabilizing flanges 50, as illustrated in FIG. 3, the sidewalls 32 of the forward frame segment 26 could simply have a greater width, or a rearward portion of the sidewalls 32 can be bent to define a greater width, to accommodate the rearward frame segment 28, all within the scope of the present invention.

[0037] Further, the stabilizing flanges could alternately be mounted on the rearward frame segment 38, and overlap the forward frame segment 26. Additionally, rather than side flanges, differing longitudinal projection(s) could be included on either the forward or rearward frame segment 26 or 28 to be closely and slidably received within a corresponding slot, recess or space in the other of the forward or rearward frame segments.

[0038] Other than the overlapping of the stabilizing flanges 50, the forward and rearward frame segments 26 and 28 are independent of each other. Thus, the forward and rearward segments 26 and 28 are free to pivot and slide relative to each other during flexure of the base 14, without restriction. To further facilitate this sliding pivotal movement of the forward and rearward frame segments 26 and 28, a low friction surface, such as a Teflon™ fluoride polymer pad 56, is preferably applied to the exterior of the forward ends of each of the sidewalls 36 of the rearward frame segment 28. Alternately, the low friction pads 56 can be applied to the interior of the stabilizing flanges 50, or to both the stabilizing flanges 50 and the rearward frame segment 28. Although low friction materials, such as nylon pads, or bearings, could also be utilized. Thus, frictional resistance between movement of the forward and rearward frame segments 26 and 28 is minimized. The flexure of the base 14 is limited only by the skater's foot positioning and activity, and the biasing of the base 14 (to be discussed below) rather than by the frame assembly 16.

[0039] Referring to FIGS. 1 and 3, the frame assembly 16 includes a mechanism for selectively locking the forward frame segment 26 to the rearward frame segment 28, so that the frame assembly 16 becomes rigid along its length. This may be desired, for instance, by beginning skaters who may be more comfortable on a rigid frame. In the preferred embodiment illustrated, a locking pin 58 having a head on one end and spring loaded detent ball on the opposing end, may be inserted if desired through aligned apertures 60 formed in each of the stabilizing flanges 50 and the forward ends of the sidewalls 36 of the rearward frame segment 28. When the base 14 is unflexed such that the forward and rearward frame segments are longitudinally aligned, as shown in FIG. 1, the locking pin may be inserted if desired. Removal of the locking pin 58, by pushing of the locking pin 58 with an alien wrench or other tool from the detent side, restores the skate to the flexing configuration.

[0040] Referring again to FIG. 3, each of the forward and rearward frame segments 26 and 28 is mounted to the base 14 for independent lateral and horizontal adjustment. For this purpose, the base 14 includes a spaced series of four transverse mounting slots 62. Each mounting slot 62 is bordered by a downwardly projecting boss. Each mounting slot 62 is reinforced by a corresponding slotted metal plate molded or adhered within the base 14, midway between the upper surface 30 and the lower surface 40. The reinforcing plates may be suitably formed of a metal such as aluminum,

and each defines a lip 63 projecting internally about the perimeter of the corresponding slot 62. The head of a stud 64 is received within each slot from the upper surface of the base 14, and rests on the lip 63 defined by the reinforcing plate. Each stud 64 includes an internally threaded stem that extends downwardly through the slot 62 and lip 63. The studs 64 can be slid laterally from side to side along the length of the slots 62.

[0041] The top wall 31 of the forward frame segment 26 includes two longitudinally oriented mounting slots 66. The top wall 34 of the rearward frame segment 28 includes two longitudinally oriented mounting slots 66 as well. The longitudinal mounting slots 66 at the forward frame segment 26 are alignable with the two forwardmost transverse mounting slots 62 formed in the base 14. These forwardmost mounting slots 62 are formed within the forefoot region 20 of the base 14, just below the toes and just forwardly of the metatarsal head portion 22. Mounting bolts 68 are inserted from the underside of the forward frame segment 26, through the longitudinal slots 66 into the corresponding studs 64 to mount the forward frame segment 26 to the forefoot region 20 of the base 14. When the bolts 28 are loosely received in the studs 64, the forward frame segment 26 can be slid forwardly and rearwardly along the length of the slot 66, and can also be slid transversely left or right along the length of the slots 62. When the desired forward and rearward location and side to side location, as well as angulation, is achieved, the bolts 68 are tightened into the studs 64 to retain the forward frame segment in this position.

[0042] Similarly, mounting bolts 68 are inserted through the longitudinal slots 66 in the rearward frame segment 28, and into the studs 64 retained in the two rearmost transverse slots 62 of the heel region 24 of the base 14. The two rearmost transverse slots 62 are defined immediately below the heel and below the arch of the base 14. The rearward frame segment 28 can be longitudinally, laterally and angularly adjusted just as can the forward frame segment 26. The forward and rearward frame segments 26 and 28 can be adjusted independently of each other.

[0043] The adjustable mounting of the forward and rearward frame segments 26 and 28 makes possible the lengthening and shortening of the frame assembly 16 of the skate 10. A longer frame may be desired for increased speed, while a shorter frame may be desired for increased maneuverability. Likewise, the left and right positioning of the frame segments may be desired for individual skating styles to facilitate straight tracking or turning.

[0044] Referring to FIGS. 1 and 2, the mounting of the forefoot region 20 of the base 14 to the forward frame section 26 provides for a stable platform from which to push off of during the thrust portion of a skating stroke. Specifically, the point of flexure of the base 14, at the metatarsal head portion 22, is disposed either just above or forwardly of the axis of rotation of the innermost forward wheel 18b of the forward frame segment 26. The axis of rotation of the innermost forward wheel 18b is defined by the corresponding axle 45, and corresponds to the point of contact of the innermost forward wheel 18b with the ground. Thus, during flexure of the skate, when the rearward frame segment 28 and rearward wheels 18c and 18d are lifted off of the ground, a stable platform is still provided because the rearwardmost contact point with the ground provided by the wheel 18b is

either immediately below or behind the point of flexure at the metatarsal head portion 22. This prevents the forward frame segment 26 from undesirably tipping upward, so that the forwardmost forward wheel 18a would raise off the ground, during the thrust portion of the stroke.

[0045] Referring to FIGS. 2 and 4, the flexing skate 10 of the present invention preferably includes a biasing member to urge the base 14 downwardly to the lower or unflexed configuration of FIG. 1, and away from the upper or flexed configuration of FIG. 2. Preferably, this biasing is provided by a spring incorporated into the base 14 that is coplanar with the base 14. For example, the base 14 can be constructed from a resilient composite material, such as a thermosetting or thermoplastic polymer reinforced by fibers. One suitable example of such a resilient composite material is an epoxy reinforced with plies of carbon fibers, woven at 45° angles relative to the longitudinal axis of the base 14. This construction results in the transverse metatarsal head portion 22 still retaining torsional stiffness, while also resiliently flexing longitudinally.

[0046] An alternate method of incorporating a spring into the base 14 is illustrated in FIG. 4. Specifically, a wide, elongate recess 70 is formed in the upper surface 30 of the base 14. The recess 70 extends across a majority of the width of the base 14, and from the forward end of the toe region 20 of the base 14, just behind the forwardmost mounting slot 64, to approximately midway along the length of the base 14, just forwardly of the third mounting slot 64. This shallow recess 70 receives a spring plate 72 which spans the width and most of the length of the recess. The spring plate 72 passes over and is centered on the metatarsal head portion 22. The spring plate 72 may be suitably formed as a strip of spring steel, or alternately may be a strip of other resilient material such as a reinforced composite. The spring plate 72 is suitably adhered in place, or may be retained by rivets. In the preferred embodiment, the spring plate is adhered between the base 14 and the upper shoe portion 12 on both the upper and lower surfaces during the lasting process. Additionally, four rivets 74 are inserted through the base 14 and each corner of the spring plate 72 through corresponding short longitudinal slots 76 formed in the spring plate 72. This allows some longitudinal shifting of the spring plate 72 relative to the base 14 during flexure of the base 14. The recess 70 may also include two transverse elastomeric strips 78 positioned forwardly and rearwardly of, and abutting, the forward and rearward ends of the spring plate 72. These elastomeric strips 78 compress and absorb the longitudinal movement of the spring 72, as permitted by the slots 76, during flexure of the base 14. Upon return of the base 14 to the unflexed configuration, the elastomeric strips 78 decompress, thereby further urging the spring 72 to its original configuration with additional force.

[0047] Referring to FIGS. 1 and 2, the spring plate 72 acts to urge the heel region 24 of the skate 10 downwardly to the unflexed configuration of FIG. 1. Moreover, the spring plate 72 is preferably preloaded such that it biases the heel region 24 of the base 14 downward sufficiently to introduce a negative camber to the longitudinal orientation of the wheels 18a, b, c, and d. Specifically, FIG. 1 illustrates a planar ground surface 76 across which a skater may traverse. Before the weight of the skater's body is introduced to the base 14, the skate 10 is biased by the spring plate 72 such that the intermediate wheels 18b and c are elevated slightly

relative to the forwardmost wheel **18a** and rearwardmost wheel **18d**. Thus, the bottom surfaces of the wheels define a plane arcing slightly downwardly, as illustrated by line **78** in **FIG. 1**. As soon as the user's weight is applied to the base **14**, the intermediate wheels **18b** and **18c** move downwardly as the preload of the spring plate **72** is overcome, until all wheels reside on the ground in an even planar configuration. The preloading of the spring plate **72** in this manner eliminates rockering of the skate **10**, and may be utilized when an anti-rockering skate is desired. During each stroke as the skate begins to touch the ground, the intermediate wheels **18b** and **18c** will not initially contact the ground, eliminating undesired tracking during that portion of the stroke. The initial cambering of the wheels **18** ensures that proper contact of the forward and rearward wheels with the ground remains at all time.

[**0048**] While the preferred embodiment in **FIG. 1** has been illustrated with four wheels, a differing number of wheels more or less could be utilized. For instance, a greater number of wheels, such as five wheels, may be desired for greater speed.

[**0049**] During skating on the flexing skate **10**, the base **14** flexes about a laterally extending axis defined transverse to the longitudinal axis of the split frame assembly **16**. However, the reduced thickness stress concentrating contour of the metatarsal head portion **22** may be oriented alternately, such as with a slight angle relative to the longitudinal axis of the frame assembly **16**. This would thereby define a slightly angled transverse rotational axis that still more closely follows the contour of the metatarsal head of the skater's foot. The center of rotation of the base **14** and skate **10** is at a plane immediately below the metatarsal head of the skater's foot, and is preferred because centering rotation at other locations may cause the skater's foot to cramp. During skating, as the skater enters the push off phase of the skating stroke, the skater utilizing the flexing skate **10** of the present invention may plantarflex his or her ankle, while flexing his or her foot above the metatarsal head portion **22** of the base **14**. The forward frame segment **26** remains firmly on the ground as the rearward frame segment **28** elevates off the ground. The weight of the skater's foot pivots off the metatarsal head of the foot, and the weight of the skater bears down on the forward frame segment **26**. A stable platform is provided by the two forwardmost wheels **18a**, **18b**, from which the skater is able to propel himself or herself forward. This skating action is more fully described in co-pending application Ser. No. 08/957,436, the disclosure of which is hereby expressly incorporated by reference.

[**0050**] During this push off or thrusting portion of the stroke, as the heel is lifted and the foot flexes, the spring plate **72** permits thrusting off of the forward end of the skate with greater power. The spring plate **72** bends at the metatarsal head portion **22** of the skate, and the skate front loads the metatarsal head forward onto the remainder of the forefoot region **20** of the base **14**. As soon as the stroke is completed and the user releases the tension from his or her foot, the spring **72** causes the heel region **24** of the base **14** to rebound to the unflexed configuration of **FIG. 1**, with energy being returned to the skate for a continued forward stride. Moreover, the preloading of the spring plate **72** causes the skate **10** to snap down firmly and positively into the aligned, unflexed configuration.

[**0051**] Utilization of the flexing base **14** of the skate **10** provides for greater control, particularly during longer strokes. The skate remains firmly under the weight of the user during the full length of a stroke, and the user is better able to maintain his or her center of gravity in a straight line. Thus longer strokes and greater speed are provided by use of the flexing skate **10** relative to a conventional rigid frame skate. Moreover, the split frame assembly **16** and flexing base **14** of the present invention provides the skater the ability to jump off of the forward frame segment **26**, utilizing the spring action of his or her legs and feet as the foot is flexed during upward jumping movement, and rebounding after weight is removed from the skate to the unflexed configuration. Thus, jumping in the skate **10** of the present invention is possible even without the utilization of a ramp or other elevating device. The user instead simply springs off of the forward frame segment **26**.

[**0052**] An additional benefit of the split frame configuration **16** and flexing base **14** is that the skate **10** thereby provides an integral suspension system. As the skate **10** passes over bumps and protrusions in the ground during skating, either of the forward frame segment **26** or rearward frame segment **28** can lift relative to the other, with the base **14** flexing as required accordingly, to dampen shock and impact to the skater's foot. Thus greater control and higher speeds are possible. The heel of the skater's foot is able to move up and down freely of the toe of the skater's foot. Full arcuate flexing of the foot is provided by the skate of the present invention, for enhanced maneuverability, speed, and jumping abilities.

[**0053**] **FIG. 5** provides a variation on the base **14** of the skate of **FIG. 10**. **FIG. 5** illustrates an alternate base **80** that is configured the same as the base **14** previously described in most respects. However, rather than a single longitudinal recess **70** and spring plate **72**, left and right narrow elongate spring strips **82** and **84** are mounted within corresponding elongate recesses along the left and right edges of the skate, again in the forefoot region **20** of the skate and centered over the metatarsal head portion **22**. The narrow spring strips **82** and **84** are inserted laterally into the base **80** through slots defined in the perimeter of the base **80**. To this end, each of the spring strips **82** and **84** may include a tab **86** that is manually grasped, or grasped with pliers, for removal and installation of the spring strips **82** and **84**. Once installed, the spring strips **82** and **84** are closely received within the recesses, and the preloading of the springs **82** and **84** retains them in this position. This construction enables the spring strips **82** and **84** to be removed and interchanged with differing spring strips having a higher or lower spring constant for more or less biasing force, as may be desired for particular users or applications. Other forms of interchangeable or adjustable biasing elements may be utilized, such as piezoelectric transducers, all within the scope of the present invention. Piezoelectric transducers would serve the functions of dampening vibration and controlling the amount of flexure and the amount of return flex or camber preload in response to varying surface conditions, providing a responsive suspension system.

[**0054**] An alternate embodiment of a flexing base skate **100** is illustrated in **FIGS. 6 and 7**. The skate **100** again includes an upper **102** secured along its underside to a base **104**. The upper **102** and the base **104** are constructed substantially similar to the upper **12** and base **14** of the

previously described embodiment of the skate **10**. In the skate illustrated in **FIGS. 6 and 7**, the upper **102** is configured as a racing skate boot; however other configurations of skate boots such as that illustrated in **FIG. 1** may alternately be utilized. The base **104** is constructed similarly to the base **14** illustrated in **FIG. 1**, and includes a forefoot region **106** having a metatarsal head portion **108** and a heel region **110**. The base **104** incorporates a spring, which may suitably be the same as the previously described spring plate **72** illustrated in regard to the embodiment of **FIGS. 1 through 4**. Alternately, a differing spring construction, such as the use of a resilient composite material is suitable for use in the embodiment of **FIG. 6** to form the base **104** and integral spring.

[0055] **FIG. 6** illustrates such a composite base and spring, suitably constructed from a composite with fibers oriented at 45° relative to the longitudinal axis of the skate. Thus, the base **104** is of one piece construction, with the contour of the base **104** at the metatarsal head portion **108** providing for flexure of the base below the metatarsal head of the foot, and the composite material utilized to form the base **104** providing the spring force for biasing of the base **104** to the unflexed configuration shown in **FIG. 6**. The base **104** is also preferably longitudinally reinforced so that it is rigid in front of and rearwardly of the flexible metatarsal head portion **108**. Longitudinal reinforcement may be had through the incorporation of ribs, as in the previously described embodiment. Alternately, syntactic foam reinforcing strips or other reinforcing members may be incorporated into the structure of the base **104** rearwardly and forwardly of the metatarsal head portion **108**.

[0056] Skate **100** also includes a rigid longitudinal frame **112**. Unlike the previously described embodiment, the frame **112** has a one piece construction and extends the full length of the skate. The frame **112** may suitably be formed from a composite material having a downwardly opening, U-shaped, elongate channel configuration to define opposing left and right sidewalls. Alternate frame constructions, such as a torsion box construction such as that previously described, but extending in one piece along the length of the skate, may be utilized. The skate **100** further includes a plurality of wheels **114** journaled on axles **116** between the opposing sidewalls of the frame.

[0057] The forefoot region **106** of the base **104** is secured to the forward end of the frame **112**. The securement may be by two bolts (not shown) that are longitudinally spaced, which pass through apertures defined in the upper wall of the frame **112** and which are received within threaded inserts molded into or captured above the upper surface of the base **104**. Alternate constructions, such as studs that extend downwardly from the base **104** and which receive nuts received within the frame **112**, or riveting, may be utilized. The base **104** is fixedly secured to the frame **112** only at the forefoot region **106**. The base **104** is not secured and is free of the frame **112** at the metatarsal head portion **108** and rearwardly behind the metatarsal head portion **108**, including the heel region **110** of the base **104**. Thus, the heel region **110** of the base **104** may be elevated or lifted above and away from the frame **112**, with the base **104** flexing at the metatarsal head portion **108**, as shown in the flexed configuration of **FIG. 7**. Just as in the previously described embodiment, the user may flex his or her foot to lift his or her heel during the skating stroke. However, the full length of the frame **112**

remains parallel to the ground, with all of the wheels **114** contacting and rolling on the ground.

[0058] Although the heel region **104** of the base is able to elevate from the frame **112** during skating, it is still desired to maintain the heel region **104** centered above the base **112**, and to avoid torsional twisting of the base **104** that would result in the heel region **110** being displaced laterally to either side of the frame **112**. Torsional rigidity is provided to the base **104** in part by the selection of materials utilized to construct the base **104**. Thus, in the preferred embodiment utilizing a composite material, the reinforcing fibers provide a high degree of torsional rigidity while permitting flexing at the metatarsal head portion **108**. Further lateral stability and alignment of the base **104** relative to the frame **112** is provided by a guide member **118** secured to the lower surface of the base **104**, immediately below the rear end of the heel region **110**.

[0059] The guide member **118** of the preferred embodiment illustrated has an elongate U-shaped configuration, including a center top portion **120** that is bolted, riveted, or otherwise secured to the base **104**. The guide **118** further includes first and second side flanges **122** that depend perpendicularly downwardly from the top portion **120**, on either side of the frame **112**. The frame **112** is slidably and closely received between the left and right side flanges **122**. The guide **118** is preferably constructed with a high degree of rigidity. The guide **118** may suitably be constructed from a laminate of syntactic foam surrounded and encapsulated within inner and outer layers of reinforced composite material. Other materials such as aluminum may alternately be utilized. Preferably, a low friction surface is formed on either the frame **112** sidewalls or the interior of the guide **118**, so that the two members slide easily relative to each other.

[0060] During flexure of the skate between the lower, unflexed configuration of **FIG. 6** and the upper, flexed configuration of **FIG. 7**, the frame **112** remains fully or partially between the opposing side flanges **122** of the guide **118**. The heel region **110** of the base **104** thus remains centered over the frame **112**, with a high degree of lateral stability. The ability to lift the heel of this flexing base skate **100** provides an unencumbered movement of the heel, due to the low weight carried by the heel. The spring incorporated into the base **104** provides the same benefits as in the previously described embodiment, serving to bias the base **104** downwardly to the lower position of **FIG. 6**. The spring incorporated into the base **104** is preferably preloaded such that the base **104** is biased positively against the frame **112**. The advantages provided by flexing the base **104** and skate upper **102** at the metatarsal head portion are also provided by this embodiment of the present invention. However, in the embodiment of **FIGS. 6-7** all wheels maintain contact with the ground until the very end of the skating stroke, for added power and stability, and which tracks well for fitness and racing applications.

[0061] **FIG. 8** illustrates the flexing base skate **100** that is provided with a brake assembly **130**. The brake assembly **130** includes a brake arm **132** having an upper end secured to the heel region **110** of the base **104**, and that extends rearwardly and downwardly therefrom, terminating rearwardly of the rearmost wheel **114**. An elastomeric brake pad **134** is mounted, such as by a screw, to the rear end of the brake arm **132**.

[0062] The construction and mounting of the brake arm 132 is illustrated in FIG. 9. The brake arm 132 has a flattened upper portion 136 that is secured by a bolt 138 to the heel region 110 of the base 104. The guide 118 is integrally formed with the brake arm 132. Thus the upper portion 136 of the brake arm 132 serves as the top surface 120 of the guide element 118. The side flanges 122 of the guide depend downwardly from the upper surface 136 on either side of the frame 112. To further guide the alignment of the base 104 relative to the frame 112 during the initial stages of flexure, the brake arm 132 also includes a tapered cylindrical guide boss 140 projecting centrally downward from the top surface 136. The guide boss 140 does not extend downwardly as far as the side flanges 122. The guide boss 140 is slidably received within a slotted aperture 142 defined in the upper wall of the frame 112. Thus, when the skate is in the unflexed configuration of FIG. 8, the guide boss 140 is received within the slotted aperture 142, and further laterally fixes the base 104 relative to the frame 112. In this configuration, as shown in FIG. 8, the brake pad 134 is adjacent the ground. By rocking back on the rearwardmost wheel 114, the user can bring the pad 134 into engagement with the ground for braking action. During flexing of the skate 100, the brake assembly 130 travels upwardly with the heel of the skate. This construction avoids the excessive lever arm effect that may alternately result if the brake assembly were instead mounted to the frame 112.

[0063] It should be readily apparent that the centered guide boss 140 could also be incorporated into the guide 118 of FIGS. 6 and 7, whether or not the brake arm 132 is incorporated.

[0064] The free heel flexing skate of FIGS. 6 through 9 provides a shock absorption system similarly to the first preferred embodiment described previously. Thus, the heel of the skate can pivot upwardly off of the frame 112 upon passing over protuberances in the ground. The biasing of the spring incorporated into the frame 104 however prevents undesirable chattering of the base 104 relative to the frame 112. Further shock absorption may be provided by an elastomeric dampening element mounted between the base 104 and the frame 112. Thus, FIG. 9 illustrates an elastomeric grommet 144 that is fitted about the perimeter of the slotted aperture 142, including an upper lip that projects above the frame 112. When the base 104 is pivoted downwardly to the lower position, it contacts the elastomeric grommet 144, which serves to cushion the two members and dampen vibrations and shock therebetween.

[0065] It should be readily apparent to those of ordinary skill in the art that alterations could be made to the above-described embodiment. For instance, an elastomeric member could be mounted to other locations of the frame or on the base 104. Further, the guide member could be mounted on the frame to extend downwardly on either side of the base, rather than the guide member projecting downwardly on either side of the frame. Also, a guide member could alternately project upwardly from the frame and engage an aperture defined in a rearward extension of the base.

[0066] While the preferred embodiments of the invention have been illustrated and described, it will be appreciated that various changes can be made therein without departing from the spirit and scope of the invention.

The embodiments of the invention in which an exclusive property or privilege is claimed are defined as follows:

1. A roller skate having a shoe portion for receiving a skater's foot and a plurality of wheels, comprising:

a base having an upper surface securable to an underside of the shoe portion for supporting the received skater's foot, the base including a heel region and a forefoot region, the forefoot region having a metatarsal head portion; and

a frame secured to an underside of the base at least below the forefoot region of the base such that the base can flex intermediate of the forefoot region and heel region during skating to permit elevation of the skater's heel, the frame extending below the base and rotatably receiving the plurality of wheels, with at least one forward wheel disposed below the forefoot region of the base and at least one rearward wheel disposed below the heel region of the base, wherein the metatarsal head portion of the base defines a stress concentrating contour that focuses flexure of the base at the metatarsal head portion.

2. The skate of claim 1, wherein the frame mounts at least first and second forward wheels below the forefoot region of the base, the second forward wheel being disposed between the first forward wheel and the rearward wheel, an axis of rotation of the second forward wheel being directly below or rearward of the stress concentrating contour of the metatarsal head portion of the base.

3. The skate of claim 1, wherein the stress concentrating contour comprises a reduced thickness section of the base extending transversely substantially across the metatarsal head portion of the base.

4. The skate of claim 3, wherein the stress concentrating contour further comprises an aperture defined through the metatarsal head portion of the base.

5. The skate of claim 1, wherein the stress concentrating contour of the base comprises an aperture defined through the metatarsal head portion of the base.

6. The skate of claim 1, further comprising a biasing member coupled to the base to bias the heel region of the base to a lower position, in which the heel region of the base bears on the frame, the rearward wheel and the ground.

7. The skate of claim 6, wherein the biasing member is incorporated into the forefoot region of the base.

8. The skate of claim 7, wherein the base is constructed of a resilient material and integrally defines the biasing member.

9. The skate of claim 6, wherein the biasing member comprises a strip of resilient material secured along the base.

10. The skate of claim 9, wherein the biasing member is removable from the base for interchangeability.

11. The skate of claim 6, wherein the biasing member exerts a downward preload on the heel region of the base when the heel region is in the lower position.

12. The skate of claim 1, wherein the frame comprises a rigid frame extending below the base from the toe region to the heel region, and flexure of the base during skating results in elevation of the skater's heel between a lower position in which the heel region of the base bears on the frame, and an upper position in which the heel region of the base is elevated relative to the frame.

13. The skate of claim 12, further comprising a guide secured to one of the frame and the heel region of the base

and projecting toward and slidably engaging the other of the frame and the heel region of the base during flexure of the base.

14. The skate of claim 13, wherein the guide depends downwardly from the base.

15. The skate of claim 14, wherein the guide is slidably received within an aperture defined in the frame.

16. The skate of claim 15, wherein the aperture defines a slot, further comprising an elastomeric cushion surrounding a perimeter of the slot and projecting upwardly above a surface of the frame for contacting the base when the base is in the lower position.

17. The skate of claim 14, wherein the guide comprises first and second flanges projecting downwardly from the base on opposing first and second sides of the frame.

18. The skate of claim 12, further comprising a shock absorption member secured to one of the frame or base to absorb shock between the frame and base when the heel region of the base is moved to the lower position.

19. The skate of claim 18, wherein the shock absorption member comprises an elastomeric material.

20. The skate of claim 12, further comprising a brake arm carrying a brake pad for selectively engaging against the ground or a wheel, wherein the brake arm is secured to the shoe portion or the base and is carried with the shoe portion or the base during flexure of the base.

21. The skate of claim 12, further comprising a biasing member coupled to the base to bias the heel region of the base to the lower position and against the frame.

22. The skate of claim 1, wherein the frame comprises an elongate frame having a forward segment secured to the underside of the base below the forefoot region of the base, and a rearward segment secured to the underside of the base below the heel region, the forward and rearward segments of the frame mounting the forward and rearward wheels, respectively, flexing of the base resulting in elevation of the heel region on the base and the rearward frame segment relative to the forefoot region of the base.

23. The skate of claim 22, further comprising a longitudinal projection extending from one of the forward or rearward frame segments toward and slidably engaging the other of the forward and rearward frame segments when the heel region of the base is lowered and the forward and rearward segments of the frame are substantially longitudinally aligned, the forward and rearward frame segments freely sliding and pivoting relative to each other during flexure of the base.

24. The skate of claim 23, wherein the longitudinal projection comprises first and second stabilizing flanges projecting from one of the forward or rearward frame segments toward and overlapping opposing first and second sides of the other of the forward and rearward frame segments.

25. The skate of claim 24, further comprising a low friction bearing surface defined on an exterior of each of the overlapped opposing first and second sides of the forward or rearward frame segment, or on an interior of the first and second stabilizing flanges.

26. The skate of claim 24, further comprising a transverse reinforcement spanning between and secured to the first and second stabilizing flanges.

27. The skate of claim 26, wherein the overlapped first and second sides of one of the forward or rearward frame segments each define a recess that accommodates the trans-

verse reinforcement of the stabilizing flanges when the forward and rearward frame segments are longitudinally aligned.

28. The skate of claim 24, further comprising a locking element selectively engageable with the forward and rearward frame segments when the forward and rearward frame segments are substantially longitudinally aligned to prevent flexure of the base.

29. The skate of claim 22, wherein at least one of the forward and rearward segments of the frame are mounted to the base for adjustable positioning in both the longitudinal and lateral directions.

30. The skate of claim 29, wherein the other of the forward and rearward segments of the frame is also mounted to the base for adjustable positioning in both the longitudinal and lateral directions.

31. The skate of claim 22, further comprising:

at least one intermediate wheel mounted on one of the rearward and forward frame segments between the forward and rearward wheels; and

a biasing member coupled to the base to bias the heel region of the base downwardly such that when the forward and rearward segments of the frame are substantially longitudinally aligned, the intermediate wheel is slightly elevated relative to the forward and rearward wheels before a skater's weight is applied to the base.

32. A roller skate having a shoe portion for receiving a skater's foot and a plurality of wheels for traversing the ground, comprising:

a base having an upper surface securable to an underside of the shoe portion for supporting the received skater's foot, the base including a heel region and a forefoot region, the forefoot region having a metatarsal head portion;

a frame secured to an underside of the base at least below the forefoot region of the base, the frame extending below the base and rotatably receiving the plurality of wheels with at least one forward wheel disposed below the forefoot region of the base and at least one rearward wheel disposed below the heel region of the base, wherein the frame is secured to the base such that the base can flex intermediate of the forefoot region and heel region during skating to permit elevation of the skater's heel between a lower position in which the heel region of the base bears on the frame, the rearward wheel and the ground, and an upper position in which the heel region of the base is elevated relative to the forefoot region of the base; and

a biasing member coupled to the base to bias the heel region of the base to the lower position and that exerts a downward preload on the heel region of the base when the heel region is in the lower position.

33. A roller skate having a shoe portion for receiving a skater's foot and a plurality of wheels, comprising:

a base having an upper surface securable to an underside of the shoe portion for supporting the received skater's foot, the base including a heel region and a forefoot region, the forefoot region having a metatarsal head portion;

- a frame secured to an underside of the base at least below the forefoot region of the base, the frame extending below the base and rotatably receiving the plurality of wheels with at least one forward wheel disposed below the forefoot region of the base and at least one rearward wheel disposed below the heel region of the base, wherein the frame is secured to the base such that the base flexes at the metatarsal head portion during skating to permit elevation of the skater's heel between a lower position in which the heel region of the base bears on the frame, the rearward wheel and the ground, and an upper position in which the heel region of the base is elevated relative to the forefoot region of the base; and
- a biasing member coupled to the base to bias the heel region of the base to the lower position.
- 34.** A skate having a shoe portion for receiving a skater's foot and a plurality of wheels, comprising:
- a base having an upper surface securable to an underside of the shoe portion for supporting the received skater's foot, the base including a heel region and a forefoot region, and being adapted to flex intermediate of the heel region and forefoot region to permit elevation of the heel region relative to the forefoot region during skating; and
- a frame having a forward segment secured to an underside of the base below the forefoot region of the base, and a rearward segment secured to the underside of the base below the heel region, the forward frame segment mounting at least one forward wheel below the forefoot region of the base and the rearward segment mounting at least one rearward wheel below the heel region of the base, wherein one of the forward or rearward frame segments includes first and second stabilizing flanges that extend toward and slidably overlap opposing first and second sides of the other of the forward and rearward frame segments, the forward and rearward frame segments freely sliding and pivoting relative to each other during flexure of the base.
- 35.** The skate of claim 34, wherein the one of the forward or rearward frame segments that includes the first and second stabilizing flanges includes first and second sidewalls, each sidewall having a first portion in which one or more wheels are journaled and a second portion extending laterally outward and then parallel to the first portion for overlapping the other of the forward or rearward frame segments.
- 36.** The skate of claim 34, further comprising a low friction bearing surface defined on an exterior of each of the overlapped opposing first and second sides of the forward or rearward frame segment, or on an interior of the first and second stabilizing flanges.
- 37.** The skate of claim 34, further comprising a transverse reinforcement spanning between and secured to the first and second stabilizing flanges.
- 38.** The skate of claim 37, wherein the overlapped first and second sides of the one of the forward or rearward frame segments each define a recess that accommodates the transverse reinforcement of the stabilizing flanges when the forward and rearward frame segments are longitudinally aligned.
- 39.** The skate of claim 34, further comprising a locking element selectively engageable with the forward and rearward frame segments when the forward and rearward frame segments are substantially longitudinally aligned to prevent flexure of the base.
- 40.** The skate of claim 34, further comprising:
- at least one intermediate wheel mounted on one of the rearward and forward frame segments between the forward and rearward wheels; and
- a biasing member coupled to the base to bias the heel region of the base downwardly such that when the forward and rearward segments of the frame are substantially longitudinally aligned, the intermediate wheel is slightly elevated relative to the forward and rearward wheels before a skater's weight is applied to the base.
- 41.** The skate of claim 34, wherein the forefoot region of the base includes a metatarsal head portion defining a stress concentrating contour that focuses flexure of the base at the metatarsal head portion.
- 42.** The skate of claim 41, wherein the forward frame segment mounts at least first and second forward wheels below the forefoot region of the base, the second forward wheel being disposed between the first forward wheel and the rearward wheel, an axis of rotation of the second forward wheel being directly below or rearward of the stress concentrating contour of the metatarsal head portion of the base.
- 43.** The skate of claim 34, wherein at least one of the forward and rearward segments of the frame are mounted to the base for adjustable positioning in both the longitudinal and lateral directions.
- 44.** The skate of claim 43, wherein the other of the forward and rearward segments of the frame is also mounted to the base for adjustable positioning in both the longitudinal and lateral directions.
- 45.** A skate having a shoe portion for receiving a skater's foot and a plurality of wheels, comprising:
- a base having an upper surface securable to an underside of the shoe portion for supporting the received skater's foot, the base including a heel region and a forefoot region, and being adapted to flex intermediate of the heel region and forefoot region to permit elevation of the heel region relative to the forefoot region during skating; and
- an elongate frame having a forward segment secured to an underside of the base below the forefoot region of the base, and a rearward segment secured to the underside of the base below the heel region, the forward frame segment mounting at least one forward wheel below the forefoot region of the base and the rearward segment mounting at least one rearward wheel below the heel region of the base, wherein one of the forward or rearward frame segments includes a longitudinal projection extending toward and slidably engaging the other of the forward and rearward frame segments when the heel region of the base is lowered and the forward and rearward segments of the frame are substantially longitudinally aligned, the forward and rearward frame segments freely sliding and pivoting relative to each other during flexure of the base.
- 46.** The skate of claim 45, further comprising:
- at least one intermediate wheel mounted on one of the rearward and forward frame segments between the forward and rearward wheels; and

- a biasing member coupled to the base to bias the heel region of the base downwardly such that when the forward and rearward segments of the frame are substantially longitudinally aligned, the intermediate wheel is slightly elevated relative to the forward and rearward wheels before a skater's weight is applied to the base.
- 47.** The skate of claim 45, wherein the forefoot region of the base includes a metatarsal head portion defining a stress concentrating contour that focuses flexure of the base at the metatarsal head portion.
- 48.** The skate of claim 47, wherein the forward frame segment mounts at least first and second forward wheels below the forefoot region of the base, the second forward wheel being disposed between the first forward wheel and the rearward wheel, an axis of rotation of the second forward wheel being directly below or rearward of the stress concentrating contour of the metatarsal head portion of the base.
- 49.** A skate having a shoe portion for receiving a skater's foot and a plurality of wheels for traversing the ground, comprising:
- a base having an upper surface securable to an underside of the shoe portion for supporting the received skater's foot, the base including a heel region and a forefoot region; and
 - an elongate frame having a forward segment secured to an underside of the base below the forefoot region of the base, and a rearward segment secured to the underside of the base below the heel region, the forward frame segment mounting at least one forward wheel below the forefoot region of the base and the rearward segment mounting at least one rearward wheel below the heel region of the base, and at least one of the rearward and forward frame segments mounting an intermediate wheel between the forward and rearward wheels, wherein the base is adapted to flex intermediate of the forefoot region and heel region during skating to permit elevation of the skater's heel between a lower position in which the heel region of the base bears on the rearward segment of the frame, the rearward wheel and the ground, and an upper position in which the heel region of the base and rearward segment of the frame is elevated relative to the forefoot region of the base;
 - a longitudinal member coupling the forward frame segment to the rearward frame segment for increased torsional stiffness of the frame; and
 - a biasing member coupled to the base to bias the heel region of the base to the lower position.
- 50.** A skate having a shoe portion for receiving a skater's foot and a plurality of wheels, comprising:
- a base having an upper surface securable to an underside of the shoe portion for supporting the received skater's foot, the base including a heel region and a forefoot region having a metatarsal head portion, the base being adapted to flex at the metatarsal head portion during skating;
 - a frame secured to an underside of the base at the forefoot region of the base and rotatably receiving the plurality of wheels, the heel region of the base bearing on the frame in a lower position and elevating away from the frame to an upper position upon flexure of the base during skating; and
- a guide secured to one of the frame and the heel region of the base and projecting toward and slidably engaging the other of the frame and the heel region of the base during flexure of the base.
- 51.** The skate of claim 50, wherein the guide depends downwardly from the base.
- 52.** The skate of claim 51, wherein the guide is slidably received within an aperture defined in the frame.
- 53.** The skate of claim 52, wherein the aperture defines a slot, further comprising an elastomeric cushion surrounding a perimeter of the slot and projecting upwardly above a surface of the frame for contacting the base when the base is in the lower position.
- 54.** The skate of claim 51, wherein the guide comprises first and second flanges projecting downwardly from the base on opposing first and second sides of the frame.
- 55.** The skate of claim 50, further comprising a shock absorption member secured to one of the frame or base to absorb shock between the frame and base when the heel region of the base is moved to the lower position.
- 56.** The skate of claim 55, wherein the shock absorption member comprises an elastomeric material.
- 57.** The skate of claim 50, further comprising a brake arm carrying a brake pad for selectively engaging against the ground or a wheel, wherein the brake arm is secured to the shoe portion or the base and is carried with the shoe portion or the base during flexure of the base.
- 58.** The skate of claim 50, further comprising a biasing member coupled to the base to bias the heel region of the base to the lower position and against the frame.
- 59.** The skate of claim 50, wherein the forefoot region of the base includes a metatarsal head portion defining a stress concentrating contour that focuses flexure of the base at the metatarsal head portion.
- 60.** A skate having a shoe portion for receiving a skater's foot and a plurality of wheels, comprising:
- a base having an upper surface securable to an underside of the shoe portion for supporting the received skater's foot, the base including a heel region and a forefoot region having a metatarsal head portion, the base being adapted to flex at the metatarsal head portion during skating;
 - a frame secured to an underside of the base at the forefoot region of the base and rotatably receiving the plurality of wheels, the heel region of the base bearing on the frame in a lower position and elevating away from the frame to an upper position upon flexure of the base during skating; and
 - a biasing member coupled to the base to bias the heel region of the base to the lower position and that preloads the heel region of the base against the frame when the heel region is in the lower position.
- 61.** A skate including a plurality of wheels for traversing the ground, comprising:
- a shoe portion for receiving a skater's foot;
 - a base having an upper surface securable to an underside of the shoe portion for supporting the received skater's foot, the base including a heel region and a forefoot region having a metatarsal head portion, the base being adapted to flex at the metatarsal head portion during skating;

- a frame secured to an underside of the base at the forefoot region of the base and rotatably receiving the plurality of wheels, the heel region of the base bearing on the frame in a lower position and elevating away from the frame to an upper position upon flexure of the base during skating; and
 - a brake arm carrying a brake pad for selectively engaging against the ground or a wheel, wherein the brake arm is secured to the shoe portion or the base and is carried with the shoe portion or the base during flexure of the base.
62. A skate having a shoe portion for receiving a skater's foot and a plurality of wheels, comprising:
- a base having an upper surface securable to an underside of the shoe portion for supporting the received skater's foot, the base including a heel region and a forefoot

- region having a metatarsal head portion, the base being adapted to flex at the metatarsal head portion during skating;
- a frame secured to an underside of the base at the forefoot region of the base and rotatably receiving the plurality of wheels, the heel region of the base bearing on the frame in a lower position and elevating away from the frame to an upper position upon flexure of the base during skating; and
 - a shock absorption member secured to one of the frame or base to absorb shock between the frame and base when the heel region of the base is moved to the lower position.

* * * * *