



Europäisches Patentamt  
European Patent Office  
Office européen des brevets



(11) **EP 1 586 523 A2**

(12) **EUROPEAN PATENT APPLICATION**

(43) Date of publication:  
**19.10.2005 Bulletin 2005/42**

(51) Int Cl.7: **B65H 19/28**

(21) Application number: **05252212.5**

(22) Date of filing: **08.04.2005**

(84) Designated Contracting States:  
**AT BE BG CH CY CZ DE DK EE ES FI FR GB GR  
HU IE IS IT LI LT LU MC NL PL PT RO SE SI SK TR**  
Designated Extension States:  
**AL BA HR LV MK YU**

(72) Inventor: **Hobart, Aaron  
Joplin, Missouri 64802 (US)**

(74) Representative: **Henderson, Wendy Agnes  
Fitzpatricks  
1 Blythswood Square  
Glasgow G2 4AD (GB)**

(30) Priority: **16.04.2004 US 826604**

(71) Applicant: **TAMKO ROOFING PRODUCTS, INC.  
Joplin, Missouri 64802-1404 (US)**

(54) **Automated waterproofing membrane winder**

(57) An automated membrane finishing winder (10) improves the process for generating waterproofing membrane rolls (14). The winder is fed a membrane through a plurality of motorized pull rolls (20,22). A mandrel adapted to receive a pair of cores is positioned proximal to an output region of a finishing product winding

machine. An adhesive applicator traverses the width of the cores automatically to apply an adhesive to the cores, and the automated finishing product winding machine guides a leading edge of adjacent membrane sections to the adhesive strip on the respective core to start rolls of waterproofing membrane.

*FIG. 1A.*

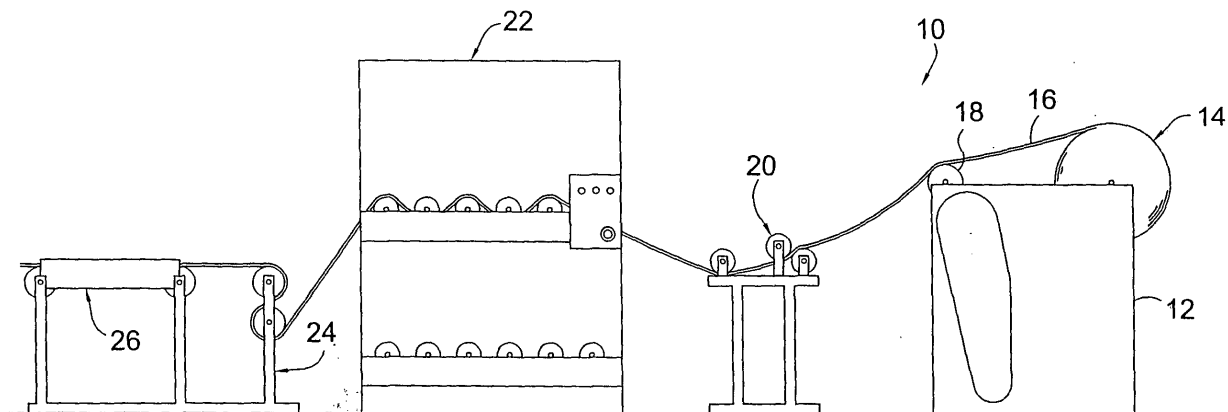

EP 1 586 523 A2

**Description**

## CROSS-REFERENCE TO RELATED APPLICATIONS

[0001] None.

## STATEMENT REGARDING FEDERALLY SPONSORED RESEARCH OR DEVELOPMENT

[0002] Not Applicable.

## BACKGROUND OF THE INVENTION

[0003] The present invention relates to an apparatus for winding membrane or other roll materials as they are produced. More particularly, the present invention relates to an apparatus and method for automating a portion of the winding process for a waterproofing membrane, thereby reducing the time and labor expense of creating the rolled membrane.

[0004] The production of waterproofing membranes is a multi-part process. In one particular process, a waterproofing membrane is manufactured on a polymer film base sheet. The polymer film base sheet may be polypropylene, polyethylene, or other polymeric sheets and is typically provided on a roll. As the term is used herein, the polymer film base sheet may also be interchangeably referred to as the base sheet or the bottom film when describing a waterproof membrane.

[0005] The polymer film base sheet is unwound continuously from the roll and fed through a waterproofing applicator. A waterproof material, such as an asphaltic material is applied to one side of the polymer film base sheet. A top film is then applied to the waterproof material layer, sandwiching the waterproof material between the top film and the base sheet. The top film is typically formed of polyethylene, polypropylene or polyester. The waterproof membrane product is cooled, accumulated and fed into a winder.

[0006] Typically in the large-width waterproof membrane production process (e.g., where a membrane of about 72 to 80 inches in width is fabricated), the membrane is cut in half longitudinally at a centerline thereof prior to being wound up for storage. The two parallel membrane sections are then wound onto adjacent paper cores, or a core of other suitable material. In current state of the art of large-width waterproofing membrane production systems, the paper cores, or other cores, are manually fitted onto the mandrel of the finished product winder. The leading edge of the membrane extending from the winder pull rolls is hand taped or otherwise secured to the core. Once the leading edge is secured to the core, the winder winds the membrane into rolls of various lengths depending on which product is being processed.

[0007] Upon completion of the roll, the trailing edge of the membrane is manually cut and the trailing edge may be taped to the roll to prevent unwinding of the fin-

ished rolled product. The roll is removed from the finished product winder and new cores are manually fitted onto the winder mandrel, and thus the process may begin again.

## BRIEF SUMMARY OF THE INVENTION

[0008] An apparatus and method for automating the process of winding a finished waterproofing membrane product is disclosed. By this apparatus and related method, downtime associated with manually cutting and taping the edges of the waterproofing membrane is reduced, while requiring one less operator for the winding process.

[0009] In one aspect, a process for manufacturing rolls of a waterproofing membrane first requires the unwinding of a roll of a first polymer film and accumulating a length of the first polymer film. The first polymer film is then fed through a waterproofing material applicator to apply a waterproofing layer on a first surface thereof. A second roll of a polymer film is unwound and combined with an exposed portion of the waterproofing layer, such that the waterproofing layer is sandwiched between the first polymer film and the second polymer film to create a waterproofing membrane. A length of the waterproofing membrane is accumulated, and is fed into a finishing winder. Cores, located on a mandrel adjacent an exit of the finishing winder and adapted to receive and wind two longitudinally divided parallel sections of the waterproofing membrane, automatically receive an adhesive glue strip. The waterproofing membrane is automatically indexed into adhesive contact with the cores, and the waterproofing membrane is wound to create adjacent rolls.

[0010] The invention of another aspect provides a process for automatically winding a waterproofing membrane, including the steps of (1) feeding the waterproofing membrane into a winding machine; (2) automatically controlling an adhesive dispenser located adjacent an output roller in the winding machine such that the adhesive dispenser places an adhesive strip on dual cores; (3) guiding a first edge of the waterproofing membrane to the adhesive strip on the core whereby the waterproofing membrane is coupled to the core; and (4) winding the waterproofing membrane onto the core. Additionally, the process may also include the steps of automatically controlling a cutting arm to laterally traverse the waterproofing membrane to make a continuous slit, and, prior to making the continuous slit, applying an adhesive strip to a width of the waterproofing membrane such that a slit edge thereof adheres to the adhesive strip.

[0011] According to another aspect, an automated membrane finishing winder is provided. The winder is fed a membrane through a plurality of motorized pull rolls. A mandrel is mounted on or adjacent to an output region of a finishing product winding machine. The mandrel is adapted to receive a core, such as a cylindrical

paper or cardboard core. An adhesive applicator traverses the width of the core automatically to apply an adhesive to the core, and the automated finishing product winding machine guides a first edge of the membrane to the adhesive strip on the core to start a roll of waterproofing.

**[0012]** An automated membrane finishing winder improves the process for generating waterproofing membrane rolls. The winder is fed a membrane through a plurality of motorized pull rolls. A mandrel adapted to receive a core is positioned proximal to an output region of a finishing product winding machine. An adhesive applicator traverses the width of the core automatically to apply an adhesive to the core, and the automated finishing product winding machine guides a leading edge of the membrane to the adhesive strip on the core to start a roll of waterproofing membrane.

**[0013]** The invention is particularly well suited for large width waterproofing membrane production. This is because it is a laborious and time-consuming process to manually apply adhesive to the expansive surface area presented by large width membranes.

#### BRIEF DESCRIPTION OF THE DRAWINGS

**[0014]** FIGS. 1A-1C schematically show an exemplary system for manufacturing waterproofing membrane.

**[0015]** FIG. 2 is a perspective view of a winding machine applying adhesive to a core.

**[0016]** FIG. 3 is a perspective view of the winding machine of FIG. 2 with a cutting device finishing the waterproofing membrane roll.

#### DESCRIPTION OF ILLUSTRATIVE EMBODIMENTS

**[0017]** One illustrative embodiment of a system for manufacturing and winding a waterproofing membrane product is shown in Figs. 1A-1C as 10. Bottom film unwind stand 12 includes a bottom film roll 14. The bottom film 16 or sheet present on the roll 14 is typically a polyethylene, polypropylene or polyester film. Bottom film 16 is unwound from bottom film roll 14 through feed rolls 18. After passing through the feed rolls 18, the bottom film 16 feeds through a splice table 20, which joins the trailing edge of a first roll of bottom film 16 with the leading edge of a second roll of bottom film (not shown) if a finished waterproofing membrane with a length longer than that of the film 16 on the bottom film roll 14 is desired.

**[0018]** The bottom film 16 is then wound through a storage looper 22, which also may be referenced as an accumulator. The storage looper 22 includes an S-wrap 24 controlling the tension in the bottom film 16 extended therethrough, and a fife guide 26 controlling the edge travel of the bottom film 16 and aligning the bottom film for passing through a coating section 28.

**[0019]** In the coating section 28 show in Fig. 1B, a heated waterproofing material 30 or coating (e.g., hot

flowable asphalt) is applied to an upper surface 32 of the bottom film 16. In embodiments where asphalt is the central waterproofing material 30, the asphalt used may be a polymer modified asphalt, such as SBS modified asphalt. Generally, polymer modified asphalts are preferred in waterproofing membrane production because of improved resistance to thermal cracking and fatigue over standard waterproofing materials typically used in similar applications. Polymer modified asphalts also possess more favorable mechanical properties over a broader temperature range of the membrane than many known waterproofing materials. However, those of skill in the art will appreciate that many other types of waterproofing materials 30 or coatings may be implemented in the design depending on the particular usage of the waterproofing membrane and desired characteristics thereof.

**[0020]** A layered film-asphalt sheet 34 formed of the waterproofing material 30 layered on the bottom film 16 is then passed through a cooling section 36, where a portion of the heat present in the waterproofing material (e.g., flowable asphalt) is transferred to cooling cylinders 38 through thermal conduction. The cooling cylinders 38 have a flow of water (or other material) maintained therein to provide a thermal sink.

**[0021]** A top film unwind stand 40, from which a web of top film 42 or sheet is paid out, is disposed generally above the layered film-asphalt sheet 34. The top film 42 may be of a material similar to that of the bottom film 16, such as a polyethylene, polypropylene or polyester. The top film 42 is continuously unwound and passed through splice rolls 44 and feed rolls 46, and subsequently the unwound film is bonded to an exposed surface 48 of the layer of waterproofing material 30 in a combining section 48. The top film 42 is pressed into the waterproofing material 30 (e.g., asphalt) by a roller after cooling. A completed waterproofing membrane section 50, in this embodiment, now includes a layer of waterproofing material 30, preferably a polymer modified asphalt, a first polymer film 16 layer located below the polymer modified asphalt, and a second polymer film 42 layer located above the polymer modified asphalt. Thus, the waterproofing material 30 is sandwiched between the film layers 16 and 42.

**[0022]** Continuing the manufacturing process, as shown in Fig. 1C, the waterproofing membrane 50 is then wound through another tension controlling S-wrap 52, and passed onto a finished product looper or accumulator 54. Downstream of the accumulator 54, the membrane 50 is pulled through exit pull rolls 56 that feed into a fife guide 58. Fife guide 58 controls the lateral edge travel of the membrane 50 and aligns it for entry into the finishing product winding machine 60.

**[0023]** If the waterproofing membrane 50 is of the large-width type (e.g., 72 to 80 inches wide), the membrane 50 is preferably cut longitudinally in half as it approaches the finishing product winding machine 60 such that two adjacent parallel membrane sections - having

a width that is about half of the original membrane 50 - are fed into the finishing product winding machine 60. Alternatively, the membrane 50, or the component layers thereof, may be cut longitudinally earlier in the manufacturing process.

**[0024]** Finishing product winding machine 60 includes motorized winder pull rolls 62 that pull the completed waterproofing membrane 50 sections into the machine 60. The finishing product winding machine 60 may also include a plurality of roller guides 64 that direct and carry the membrane sections to a pair of removable cores 66 mounted on a mandrel 68 adjacent the output region of the machine 60.

**[0025]** Cores 66 preferably are of the tubular or cylindrical type (e.g., circular or oval in cross-section) typically used in industry, such as paper, cardboard, or other commonly used materials, but may be formed of any material onto which waterproofing membrane 50 may be wound. In one embodiment, each core 66 is rotationally coupled to the mandrel 68 adjacent to one another by inflating the mandrel 68 within the enclosed area of each core, to create a tight friction fit that limits rotational misalignment. When roll sections of the waterproofing membrane 50 are completed with a desirable length of membrane, the mandrel 68 can be deflated allowing the pair of finished rolls to be removed. When new cores are installed, the mandrel 68 can be reinflated. However, no particular means of attaching the cores to the mandrel are required, and other means of attachment may be equally functional and suitable for use in the present system 10.

**[0026]** An adhesive dispenser 70, shown in Fig. 2, mounts to the finishing product winding machine 60, and may be automatically controlled to apply adhesive (1) to the cores 66 at the start of a waterproofing membrane roll, and (2) to a trailing or slit edge of the adjacent sections of the waterproofing membrane 50 after a section has been slit (as will be more fully explained herein and seen in Fig. 3) such that the edge can adhere to the membrane roll.

**[0027]** As shown in Fig. 2, an adhesive strip 72 may be applied to the outer surface 73 of the cores 66 along the axial length thereof using the adhesive dispenser 70 in continuous bead, or at specific intervals (e.g., every few inches). In a preferred embodiment, the adhesive strip 72 is a continuous glue strip applied for a length along each core 66 approximately equal to the lateral width of the waterproofing membrane 50 section being wound thereon. A fugitive adhesive glue is preferred to create the membrane-to-core seal because this type of glue maintains its tack and is removable.

**[0028]** After the adhesive strip 72 is applied to the core 66, the finishing product winding machine 60 guides a leading or first edge 74 of each completed waterproofing membrane 50 section to the adhesive strip 72. Accordingly, the first edge 74 of each waterproofing membrane 50 section is coupled to the corresponding core 66, and thus a new roll 76 of waterproofing membrane may be

wound thereon. The sequence for applying an adhesive to each core 66 (which is coupled to mandrel 68) in the finishing product winding machine 60 may be electronically controlled (e.g., by computer numeric control, etc.), and the control may be provided by logic circuits integral to the finishing winder's motor control, or by one or more ASICs, microprocessors, or computers.

**[0029]** Fig. 3 shows a cutting device 80 that may be attached to, or integral with, an arm 82 to laterally traverse the width of each completed membrane 50 section when the roll is at a desired size for the commercial use. The cutting device 80 may be mounted with a movable track within the arm 82, or the arm 82 itself may be movable with respect to the finishing product winding machine 60. The cutting device 80 slits the width of each completed membrane 50 section to create the final edge of the rolled membrane sections. In one embodiment, the cutting device 80 may be electronically controlled, and sequenced automatically, as discussed above with regard to the adhesive dispenser 70.

**[0030]** In an alternative embodiment, adhesive device 70 may be carried on the same arm 82 as cutting device 80. Further, the adhesive device 70 and cutting device 80 may be subject to joint electronic control, or may be separately controlled.

**[0031]** The system 10 and the process described herein provide a particular advantage in the manufacture of relatively wide rolls of waterproof membrane slit into half width sections. This is because of the labor and time necessary to apply the adhesive to the dual membrane rolls manually with any efficiency.

#### Example

**[0032]** In exemplary tests of the automated winder system, the cycle time from the start of a roll to finished product rolled membrane sections on dual cores was reduced approximately thirty percent as a result of using the automated system 10 versus manually applying adhesives to form the roll sections. Further, the automated system 10 required only a single operator, instead of the two operators that were previously required to adhere the waterproofing membrane to the cores and to finish the roll.

**[0033]** Since certain changes may be made in the above system and method without departing from the scope hereof, it is intended that all matter contained in the above description or shown in the accompanying drawing be interpreted as illustrative and not in a limiting sense. It is also to be understood that the following claims are to cover certain generic and specific features described herein.

#### 55 **Claims**

1. A apparatus (60) for automated finishing winding of a membrane section (50) having a leading edge and

a width, the apparatus comprising:

at least one motorized pull roll (62) for feeding the membrane section into a finishing product winding machine;

5

a mandrel (68) disposed proximal to an output region of the finishing product winding machine and adapted to receive a core (66);

10

an automated adhesive applicator (70) configured for traversing at least a portion of the length of the core parallel to the axis thereof to apply an adhesive material to the core; and

15

a guide to index the leading edge of the membrane section (50) to the core (66).

2. The apparatus of claim 1, wherein the automated adhesive applicator is electronically controlled.

20

3. The apparatus of claim 2, wherein electronic control is provided by one or more controllers selected from the group consisting of ASICs, microprocessors, and computers.

25

4. The apparatus of claim 1, further comprising:

a cutting device (80) attached to an arm (82) and configured for traversing the width of the membrane section; and

30

an electronic controller to control the cutting device.

35

5. The apparatus of claim 4, wherein the adhesive applicator is coupled to the arm.

6. The apparatus of claim 1, wherein the membrane section is a waterproofing membrane sheet having a width of at least 2 meters.

40

7. The apparatus of claim 6, wherein the waterproofing membrane sheet comprises:

45

- a) a layer of modified asphalt (30);
- b) a first polymer sheet (16) disposed below the layer of modified asphalt; and
- c) a second polymer sheet disposed above the layer of modified asphalt (42).

50

8. A process for automatically winding a waterproofing membrane section having a leading edge and a width, comprising:

55

feeding the waterproofing membrane section (50) into a finishing product winding machine (60);

automatically controlling an adhesive dispenser (70) located adjacent an output region of the finishing product winding machine such that the adhesive dispenser places an adhesive strip (72) on a core (66) along an axial length thereof;

guiding a first edge of the waterproofing membrane to the adhesive strip on the core to couple the waterproofing membrane section to the core; and

winding the waterproofing membrane section onto the core.

9. The process of claim 8, wherein the adhesive is a fugitive adhesive glue.

10. The process of claim 8, wherein the core is a cylindrical core.

11. The process of claim 8, wherein the adhesive strip is applied in a continuous line along the axial length of the core for approximately the width of the waterproofing membrane section.

12. The process of claim 8, wherein the waterproofing membrane section is a first waterproofing membrane section, the process further comprising:

automatically controlling a cutting arm to laterally traverse the first waterproofing membrane section to make a continuous slit to separate the first section from a subsequent second waterproofing membrane section and form the first section with a slit edge; and

applying an adhesive strip to a width of the first waterproofing membrane section prior to making the continuous slit, such that the slit edge of the first waterproofing membrane section has the adhesive strip disposed thereon.

13. A process for manufacturing rolls of a waterproofing membrane having a width, comprising:

unwinding a roll of a first polymer film;

accumulating a length of the first polymer film;

feeding the first polymer film through a waterproofing material applicator whereby a waterproofing layer is applied on a top surface of the first polymer film and presents an exposed surface;

unwinding a roll of a second polymer film;

applying the second polymer film onto the exposed surface of the waterproofing layer such that the waterproofing layer is sandwiched between the first polymer film and the second polymer film to create the waterproofing membrane; 5

accumulating a length of the waterproofing membrane; 10

feeding the waterproofing membrane into a finishing product winding machine;

automatically applying an adhesive strip to a core, the core disposed adjacent an output region of the finishing product winding machine and adapted to receive and wind the waterproofing membrane; 15

automatically indexing the waterproofing membrane into adhesive contact with the core; and 20

winding the waterproofing membrane on the core to create a roll. 25

14. The process of claim 13, wherein the waterproofing layer is an asphaltic layer.
15. The process of claim 14, wherein the asphalt layer comprises a polymer modified asphalt. 30
16. The process of claim 13, wherein the adhesive strip comprises a fugitive adhesive glue.
17. The process of claim 13, wherein the adhesive strip is applied along the core at a length that is approximately equal to the width of the waterproofing membrane. 35

40

45

50

55

FIG. 1A.

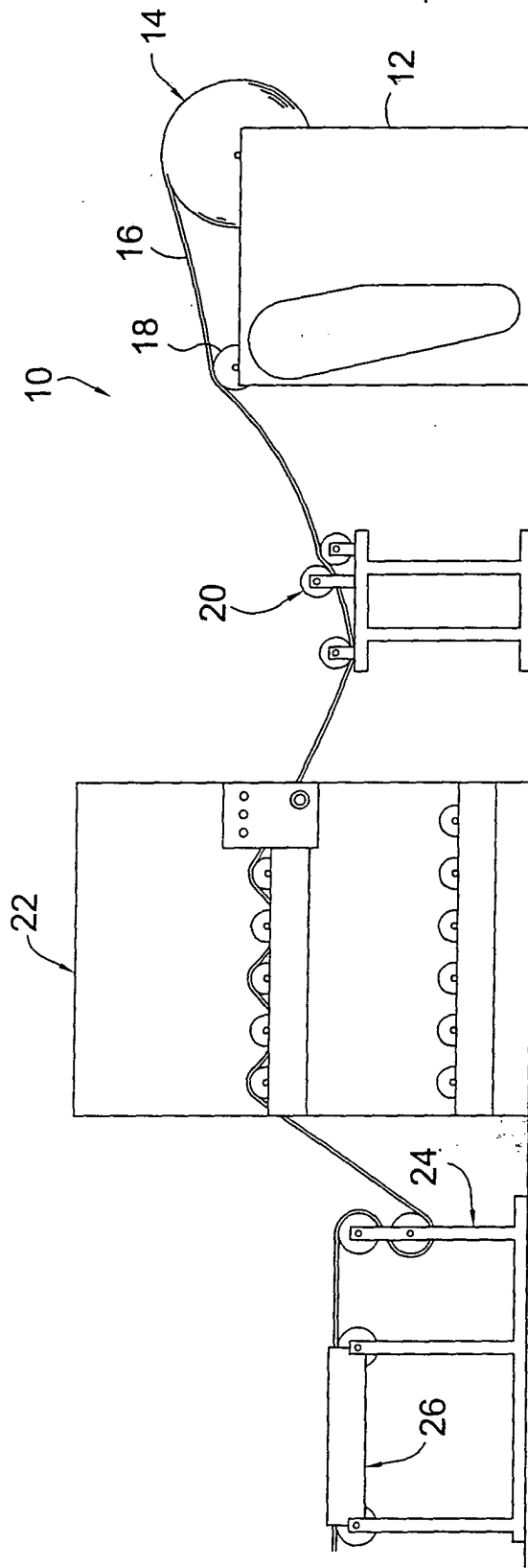
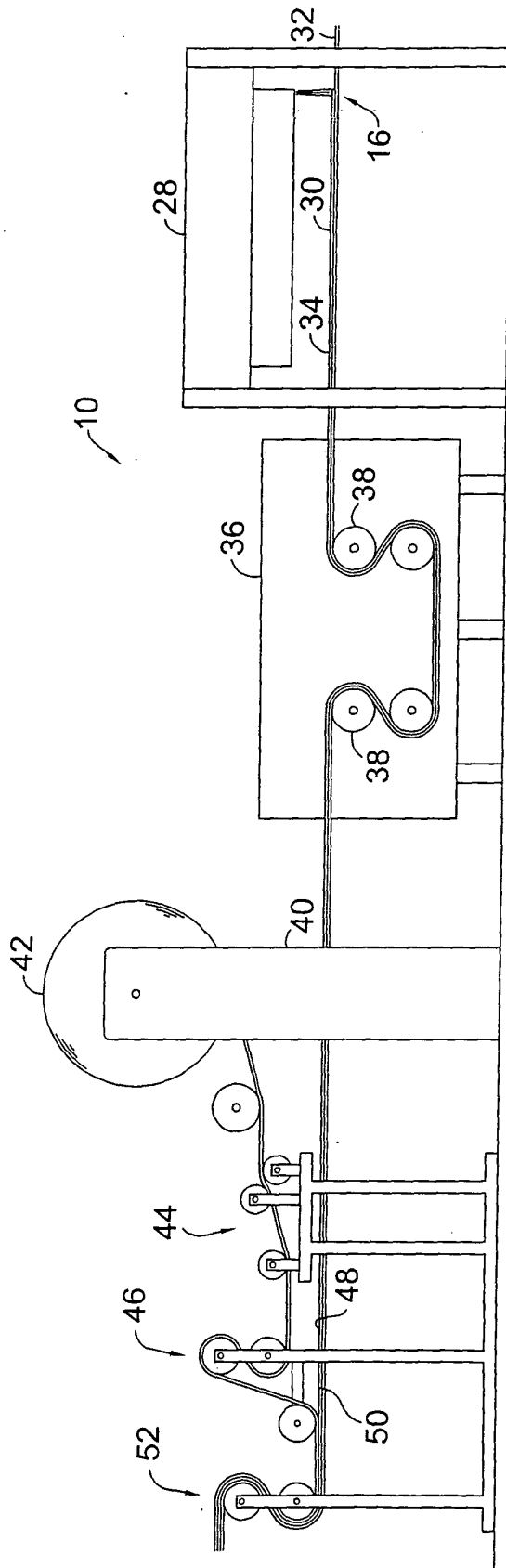

FIG. 1B.





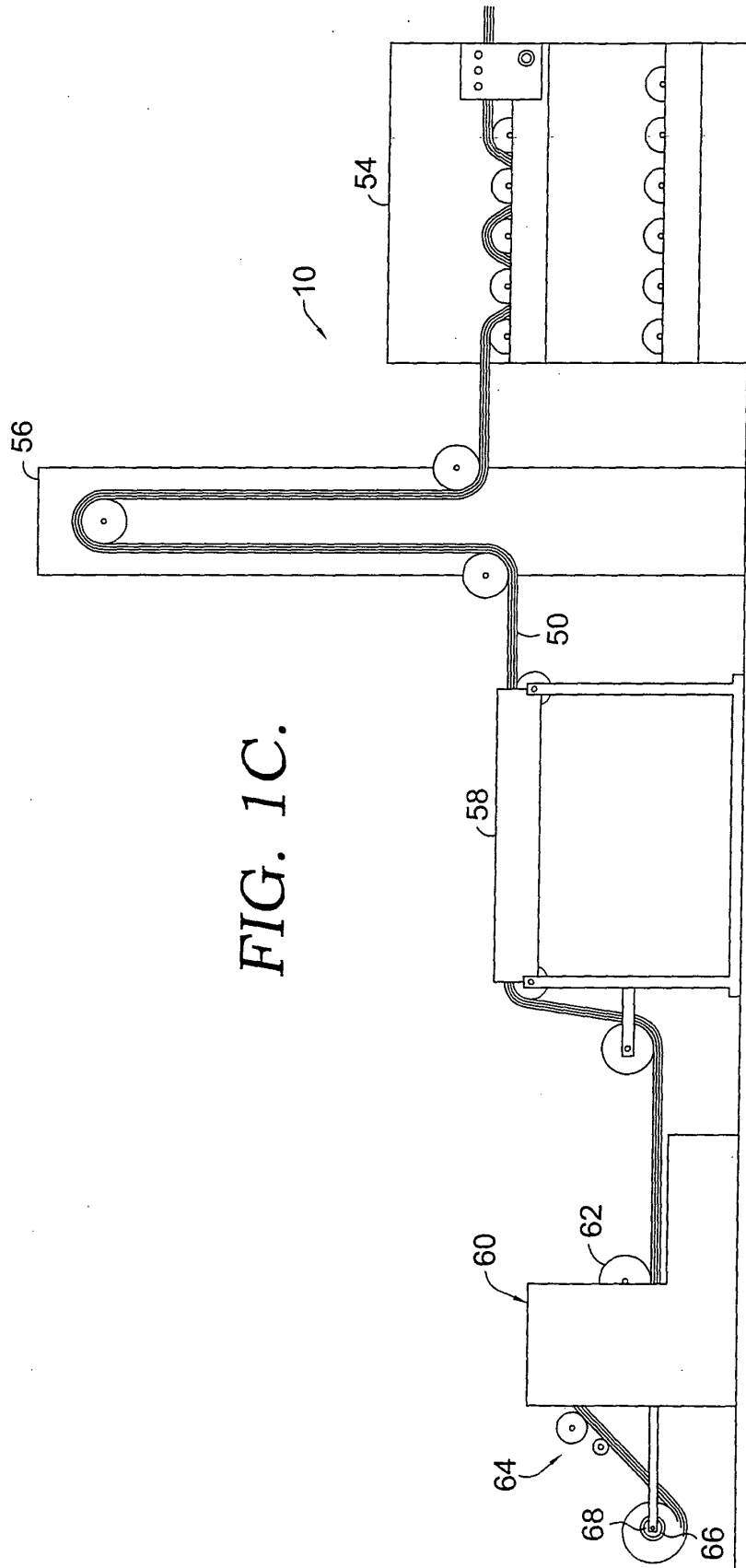

FIG. 1C.

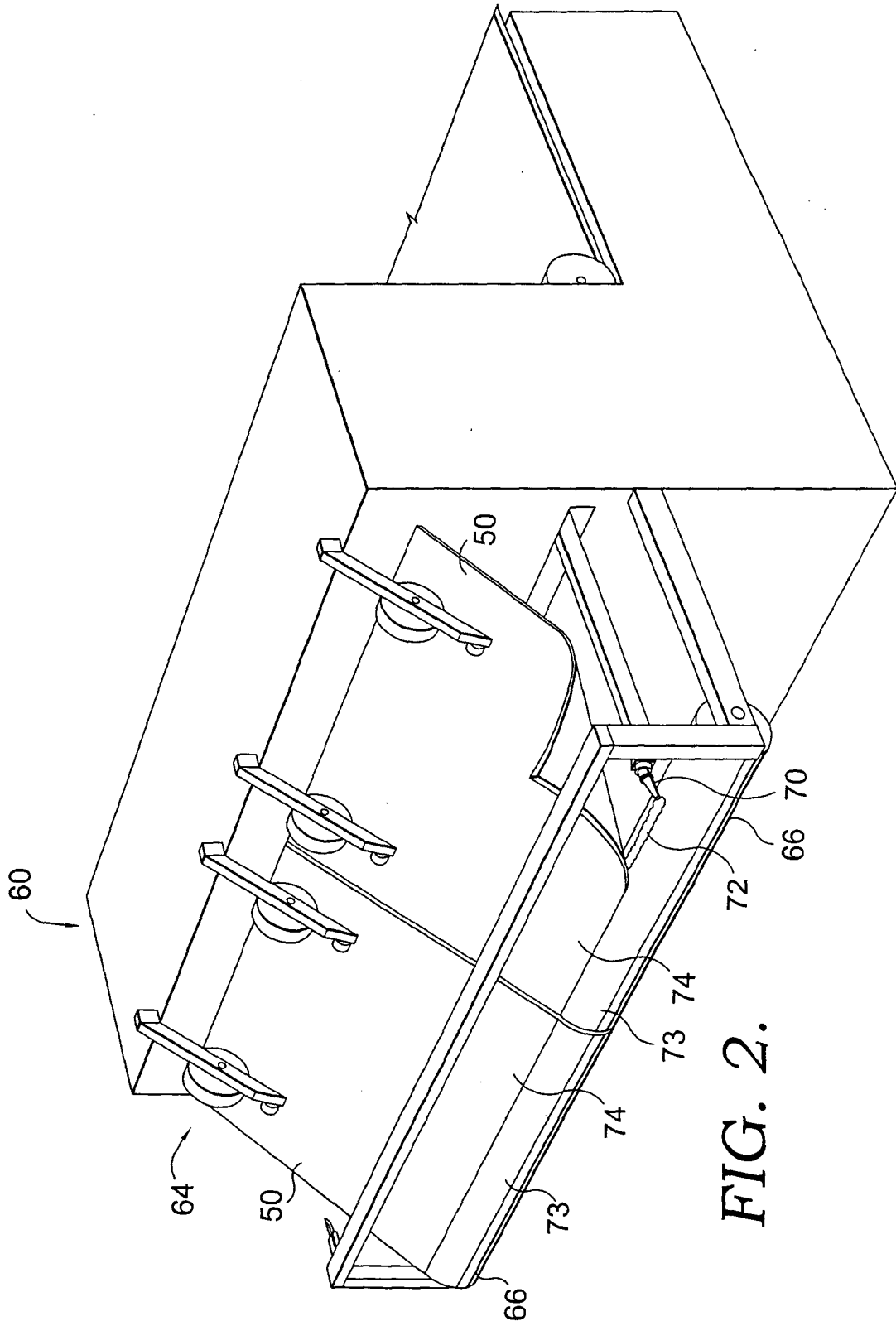

FIG. 2.

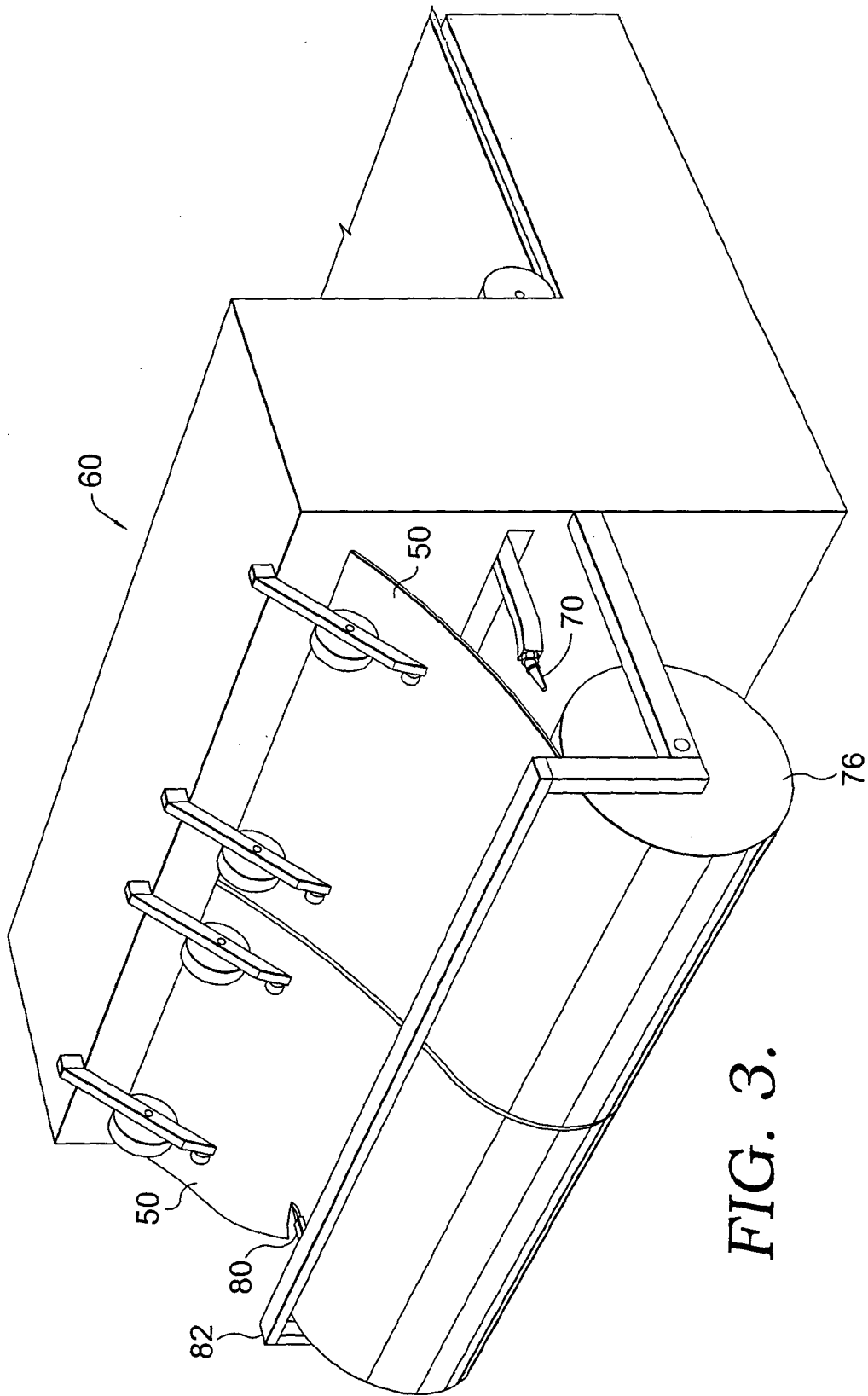

FIG. 3.