



- (51) International Patent Classification:  
*B60R 1/04* (2006.01)    *H01Q 1/32* (2006.01)  
*B60R 1/12* (2006.01)
- (21) International Application Number:  
PCT/US2015/061306
- (22) International Filing Date:  
18 November 2015 (18.11.2015)
- (25) Filing Language: English
- (26) Publication Language: English
- (30) Priority Data:  
62/081,101 18 November 2014 (18.11.2014) US
- (71) Applicant: GENTEX CORPORATION [US/US]; 600 North Centennial Street, Zeeland, Michigan 49464 (US).
- (72) Inventors: KRAUS, Andreas; Breslauer Strasse 5, Bad Friedrichshall, 74177 Baden-Wuerttemberg (DE). KOLESZAR, Christopher J.; 600 North Centennial Street, Zeeland, Michigan 49464 (US). JAEGER, Sebastian C.; 600 North Centennial Street, Zeeland, Michigan 49464 (US).

(74) Agent: CALLAGHAN, Terry S.; Price Heneveld LLP, 695 Kenmoor, S.E., P.O. Box 2567, Grand Rapids, Michigan 49501-2567 (US).

(81) Designated States (unless otherwise indicated, for every kind of national protection available): AE, AG, AL, AM, AO, AT, AU, AZ, BA, BB, BG, BH, BN, BR, BW, BY, BZ, CA, CH, CL, CN, CO, CR, CU, CZ, DE, DK, DM, DO, DZ, EC, EE, EG, ES, FI, GB, GD, GE, GH, GM, GT, HN, HR, HU, ID, IL, IN, IR, IS, JP, KE, KG, KN, KP, KR, KZ, LA, LC, LK, LR, LS, LU, LY, MA, MD, ME, MG, MK, MN, MW, MX, MY, MZ, NA, NG, NI, NO, NZ, OM, PA, PE, PG, PH, PL, PT, QA, RO, RS, RU, RW, SA, SC, SD, SE, SG, SK, SL, SM, ST, SV, SY, TH, TJ, TM, TN, TR, TT, TZ, UA, UG, US, UZ, VC, VN, ZA, ZM, ZW.

(84) Designated States (unless otherwise indicated, for every kind of regional protection available): ARIPO (BW, GH, GM, KE, LR, LS, MW, MZ, NA, RW, SD, SL, ST, SZ, TZ, UG, ZM, ZW), Eurasian (AM, AZ, BY, KG, KZ, RU, TJ, TM), European (AL, AT, BE, BG, CH, CY, CZ, DE, DK, EE, ES, FI, FR, GB, GR, HR, HU, IE, IS, IT, LT, LU, LV, MC, MK, MT, NL, NO, PL, PT, RO, RS, SE, SI, SK,

[Continued on next page]

(54) Title: REARVIEW MIRROR ASSEMBLY WITH ANTENNA

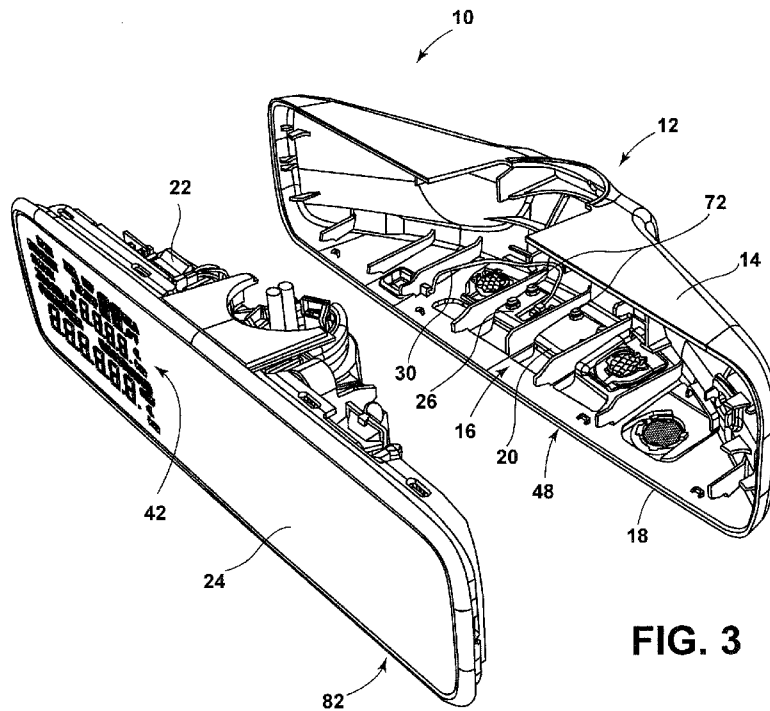


FIG. 3

(57) Abstract: A rearview mirror assembly includes a main housing defining an exterior surface, an interior, and an open side, the exterior surface having a recess therein. The assembly also includes a control module coupled within the interior of the housing, a mirror coupled over the open end of the housing, and a communication module. The communication module includes an antenna electrically coupled with the control module and an antenna housing at least partially enclosing the antenna and coupled within the recess of the exterior surface of the main housing.

WO 2016/081580 A1

SM, TR), OAPI (BF, BJ, CF, CG, CI, CM, GA, GN, GQ,  
GW, KM, ML, MR, NE, SN, TD, TG).

— *as to the applicant's entitlement to claim the priority of  
the earlier application (Rule 4.17(iii))*

**Declarations under Rule 4.17:**

— *as to applicant's entitlement to apply for and be granted  
a patent (Rule 4.17(ii))*

**Published:**

— *with international search report (Art. 21(3))*

**REARVIEW MIRROR ASSEMBLY WITH ANTENNA****TECHNOLOGICAL FIELD**

**[0001]** The present disclosure relates generally to a rearview mirror assembly for a vehicle. In particular, the rearview mirror assembly includes a communication module including an antenna coupled with a housing thereof.

**BACKGROUND**

**[0002]** Various rearview mirror assemblies have been adapted to implement at least some functionality of a metering system useable in taxis, livery vehicles, and other “for-hire” driven vehicles. Such function may include metering and the corresponding calculation of a total fee due based on, for example, distance driven in light of a predetermined fare and, potentially, including various fees, taxes, and tips. Accordingly, further improvements may be desired to facilitate the payment of such fees using an adapted rearview mirror assembly.

**SUMMARY**

**[0003]** According to one aspect of the present invention, a rearview mirror assembly includes a main housing defining an exterior surface, an interior, and an open side, the exterior surface having a recess therein. The assembly also includes a control module coupled within the interior of the housing, a mirror coupled over the open end of the housing, and a communication module. The communication module includes an antenna electrically coupled with the control module and an antenna housing at least partially enclosing the antenna and coupled within the recess of the exterior surface of the main housing.

**[0004]** According to another aspect of the present invention, a near-field communication module includes an antenna unit having a substrate defining a perimeter sidewall extending between a first face and a second face. The substrate further defines a plurality of apertures extending between the first face and the second face. The module further includes a housing comprising an elastomeric material. The housing includes a body defining an interior cavity. The substrate of the antenna unit is received within the cavity with the body extending over the first face, the perimeter sidewall, and an edge

defined between the perimeter sidewall and the second face. The housing also includes a plurality of mounting posts that extend from the cavity of the body and further through respective ones of the plurality of apertures.

[0005] These and other features, advantages, and objects of the present device will be further understood and appreciated by those skilled in the art upon studying the following specification, claims, and appended drawings.

#### **BRIEF DESCRIPTION OF THE DRAWINGS**

- [0006] FIG. 1 is a front-top perspective view of a rearview mirror assembly;
- [0007] FIG. 2 is a rear-bottom perspective view of the rearview mirror assembly of FIG. 1;
- [0008] FIG. 3 is an exploded view of the rearview mirror assembly of FIG. 1;
- [0009] FIG. 4 is a partial view of an interior of a vehicle including the rearview mirror assembly of FIG. 1;
- [0010] FIG. 5 is a detail view of an interior of the rearview mirror assembly of FIG. 1 showing the coupling of a communication module with a main housing thereof;
- [0011] FIG. 6 is front-perspective view of an antenna included in the rearview mirror assembly of FIG. 1;
- [0012] FIG. 7 is a front-perspective view of a communication module including the antenna of FIG 6 and an antenna housing;
- [0013] FIG. 8 is a detail view of the interior of the rearview mirror assembly of FIG. 1 during a step in assembly of the communication module with the main housing;
- [0014] FIG. 9 is a front-perspective view of an alternative antenna housing useable in a variation of a rearview mirror assembly;
- [0015] FIG. 10 is a detail view of an interior of a rearview mirror assembly showing the coupling of a communication module, including the antenna housing of FIG. 10, with a main housing;
- [0016] FIG. 11 is a front-perspective view of an alternative antenna housing useable in a variation of a rearview mirror assembly;
- [0017] FIG. 12 is a detail view of an interior of a rearview mirror assembly showing the coupling of a communication module, including the antenna housing of FIG. 11, with a main housing;

- [0018] FIG. 13 is a front-perspective view of an alternative antenna housing useable in a variation of a rearview mirror assembly;
- [0019] FIG. 14 is a detail view of an interior of a rearview mirror assembly showing the coupling of a communication module, including the antenna housing of FIG. 13, with a main housing;
- [0020] FIG. 15 is a front-perspective view of an alternative antenna housing useable in a variation of a rearview mirror assembly; and
- [0021] FIG. 16 is a detail view of an interior of a rearview mirror assembly showing the coupling of a communication module, including the antenna housing of FIG. 15, with a main housing.

#### DETAILED DESCRIPTION OF EMBODIMENTS

- [0022] For purposes of description herein the terms “upper,” “lower,” “right,” “left,” “rear,” “front,” “vertical,” “horizontal,” and derivatives thereof shall relate to the device as oriented in FIG. 1. However, it is to be understood that the device may assume various alternative orientations and step sequences, except where expressly specified to the contrary. It is also to be understood that the specific devices and processes illustrated in the attached drawings, and described in the following specification are simply exemplary embodiments of the inventive concepts defined in the appended claims. Hence, specific dimensions and other physical characteristics relating to the embodiments disclosed herein are not to be considered as limiting, unless the claims expressly state otherwise.
- [0023] Referring now to FIGS. 1-3, reference numeral 10 generally designates a rearview mirror assembly. Rearview mirror assembly 10 includes a main housing 12 defining an exterior surface 14, an interior 16 (as shown in FIG. 3) and an open side 18 (FIG. 3). Exterior surface 14 defines a recess 20 therein. Assembly 10 further includes a control module 22 (FIG. 3) coupled within the interior 16 of main housing 12 and a mirror 24 coupled over open end 18 of main housing 12. Assembly 10 also includes a communication module 26 having an antenna 28 electrically coupled with control module 22 (such as by wires 30) and an antenna housing 32 at least partially enclosing antenna 28 and coupled within recess 20 of exterior surface 14 of main housing 12.
- [0024] As shown in FIG. 4, rearview mirror assembly 10 can be used in an automobile interior 34 such as by coupling thereof with a headliner 36 in a position adjacent an

upper portion of windshield 38 (or by being coupled with windshield 38 itself) by way of a mounting arm 40. In an example, rearview mirror assembly 10 can be in the form of a display mirror assembly, such as by incorporation of a full or partial display 42 into mirror 24. In a further example, rearview mirror assembly 10 can be specifically adapted for use within a taxi or other livery or "for-hire" vehicle. In this respect, display 42 can be configured to present relevant information for such use, including fare information and the like. In such an example, control module 22 can be adapted to receive and/or determine information to be presented on display 42, as well as to control display 42 so as to present such information thereon. In a further embodiment, the control module 22 can further be adapted to calculate or otherwise determine such information, including by determining a distance traveled by the associated vehicle and using such information in a fee or fare calculation model. Control module 22 can receive power, data, or the like by means of cables 44 passing through a mounting aperture 46 in main housing 12, which may further pass through mounting arm 40 to couple with power and/or control systems (not shown) of the vehicle associated with interior 34.

**[0025]** In an embodiment, communication module 26 can facilitate the use of rearview mirror assembly 10 as a stand-alone metering and payment module such that incorporation of rearview mirror assembly 10 alone into vehicle interior 34 can facilitate the use of the associated vehicle as a taxi or other similar vehicle. As such, communication module 26 can house an antenna 28 in the form of a near-field communication ("NFC") antenna that is capable of communicating directly with, or facilitating communication by another component (e.g. control module 22) with, an external device that includes a compatible NFC chip. Such an "NFC enabled" device may include a specifically-adapted cellular or mobile telephone (such as a smart phone or the like), various other electronic devices, or a specifically-adapted credit card. Accordingly, a payment due, as calculated by control module 22 for example, and presented on display 42 can be made by a passenger or the like by positioning an NFC-enabled payment device within a sufficient distance (e.g. about 0.5 cm in to about 30 cm), of antenna 28, whereupon control module 22, as facilitated by communication module 26 and antenna 28, can communicate with the NFC-enabled payment device (not shown) to make such a payment, according to various processes known in the art.

**[0026]** The positioning of antenna 28 of communication module 26 in the location depicted in FIG. 2, including within an antenna housing 32 that is mounted on exterior surface 14 of main housing 12, may help provide for advantageous functioning of communication module 26. This advantageous functioning may include a desired range of communication with an external device, and may further allow for an antenna 28 that is of an appropriate size to fit within an available space on exterior surface 14 of main housing 12. As further shown in FIG. 2, positioning of antenna 28 on the bottom side of exterior surface 14 may provide a convenient location for the positioning of an external device during a payment action due to, for example, the available space under side 48 when positioned within vehicle interior 34 as shown in FIG. 4. As shown in FIG. 2, rearview mirror assembly 10 may include a plurality of buttons 50 and lenses 52 within side 48 of exterior surface 14, which may be related to other functions of rearview mirror assembly 10. The presence of such buttons 50 and lenses 52 can reduce the available space within side 48 of exterior surface 14, thereby making optimization of the function of antenna 28 desirable.

**[0027]** Referring now to FIGS. 5-7, antenna 28 is shown as including an antenna body 54 in the form of a substrate of, for example, metal or other conductive material. As such, antenna body 54 generally defines a perimeter side wall 56 extending between a first face 58 and a second face 60 (either of which can be considered a major surface of antenna body 54). A communication chip 62 can be mounted on the substrate of antenna body 54 with at least portions thereof being electrically coupled with antenna body 54 such that antenna body 54 can receive electrical signals according to an appropriate protocol. Wires 30 can be coupled with chip 62 to facilitate electrical connection between communication module 26 and control module 22. As shown in FIG. 6, antenna housing 32 includes a body 64 defining an interior cavity 66 sized to receive antenna body 54 therein. When antenna body 54 is positioned within interior cavity 66, body 64 of antenna housing 32 extends over so as to cover first face 58 and perimeter side wall 56 of antenna body 54. Further, a lip 70 of a body 64 extends inwardly with respect to interior cavity 66 so as to encapsulate an edge 68 defined between perimeter side wall 56 and second face 60 of antenna body 54. This arrangement helps to secure antenna body 54 within antenna housing 32.

**[0028]** In an embodiment, antenna housing 32 can be integrally made of an elastomer material such as thermoplastic elastomer (“TPE”), silicon rubber, or the like. In an example, antenna housing 32 can be of an elastomer having a hardness durometer of between 60 and 80, Shore A, although other materials of varying durometer hardness levels may be used, such as for the purpose of appearance or the like. The use of an elastomeric material for antenna housing 32 may facilitate a secure coupling of antenna body 54 within interior cavity 66, and may be further advantageous for preventing audible vibration and/or rattling of antenna housing 32 against main housing 12 when the two are coupled together.

**[0029]** As further shown in FIG. 6, antenna body 54 may sit within interior cavity 66 such that second face 60 is positioned within interior cavity 66. In the example shown in FIG. 7, this is achieved by configuring cavity 66 with a depth greater than the thickness of antenna body 54 (i.e. the distance between first face 58 and second face 60.) Such an arrangement may help maintain antenna body 54 in a position away from main housing 12, such as away from a portion of exterior surface 14 comprising a mounting area for antenna housing 32 to prevent rattling or other interference therebetween. In the example shown, for example in FIG. 2, the mounting area can be within and generally defined by or the same as recess 20. In other examples, the mounting area may be a portion of a generally flat exterior surface 14 of adequate size for antenna housing 32 to be mounted along such portion in a manner similar to the examples shown including a recess 20. As further shown in FIG. 7, antenna housing 32 can include a plurality of retaining features in the form of mounting posts 72 extending from body 64 within interior cavity 66 and outwardly therefrom. Further, as shown in FIG. 5, antenna body 54 can include a plurality of apertures 74 that are positioned to generally align with mounting posts 72 so that when antenna body 54 is received within interior 66, mounting posts 72 extend through apertures 74 to a position opposite antenna body 54 from the portions of antenna housing 32 from which they extend.

**[0030]** As shown in FIG. 7, communication module 26 can be assembled with main housing 12 by engagement of mounting posts 72 within a corresponding plurality of apertures of 76 within main housing 12. As shown in FIG. 7, apertures 76 can extend through main housing 12 within the area of recess 20, which is shown in FIG. 7 as extending into interior 16 of main housing 12. Accordingly, mounting posts 72 can be



configured as generally cylindrical forms with enlarged portions 78 that can be compressed so as to be press-fit through apertures 76 but are of sufficient size so as to retain mounting posts 72 in an engaged relationship with apertures 76, thereby retaining antenna housing 32 in a coupled relationship with main housing 12. As such the mounting posts 72 can have respective heights that are greater than the depth of the cavity 66 to space apart the enlarged portions 78 from the rest of antenna housing 32 and from antenna body 54. The use of an elastomeric material, as discussed above, for antenna housing 32 (which may be integrally molded of a single piece of elastomeric material) can facilitate such engagement and retention of tabs 72 with apertures 76 and can allow retention tabs 72 to be put under tension when assembled with apertures 76 such that antenna housing 32 is maintained in contact with the mounting area (e.g. within recess 20).

**[0031]** Further, as shown in FIG. 8, mounting posts 72 can be formed in an initial state with a corresponding plurality of pull tabs 80 extending therefrom. Pull tabs 80 may be present to facilitate assembly of antenna housing 32 with main housing 12 by providing material that may be grasped by an installer or by an instrument to pull mounting posts 72 through the corresponding apertures 76 in main housing 12. After installation as such, pull tabs 80 can be removed from mounting posts 72, such as by cutting or the like, which may leave corresponding portions 81 present on mounting posts 72.

**[0032]** Returning to FIG. 3, the above-described mirror 24 (including display 42) and control module 22 can be coupled together in an assembly 82 such that communication module 26 can be initially assembled with main housing 12 from within interior 60, as accessed through open side 18 of main housing 12. Subsequently, wire 30 can be appropriately coupled with control module 22 prior to coupling of assembly 82 with main housing 12. After such connection, assembly 82 can be coupled with main housing 12, such as by a snap-fit arrangement, adhesive, or other fasteners. The entire resulting rearview mirror assembly 10 can then be assembled into a vehicle interior 34, as discussed above.

**[0033]** In the various embodiments discussed herein, communication module 26 may be of a thickness approximately equal to the depth of recess 20 within exterior surface 14 of main housing 12, such that communication module 26 is generally flush with respect to the adjacent areas of exterior surface 14. In other examples, body 64 of antenna housing

32 may be somewhat thicker than the corresponding depth of recess 20 such that communication module 26 extends slightly beyond exterior surface 14 (e.g. between 0.5 and 3 mm) in still further examples, communication module 26 may be assembled on a generally planar exterior surface 14 such that no recess is present therein (at least within the area or assembly of communication module 26 thereto) such that communication module 26 extends away from exterior surface 14 by a distance generally equal to the thickness of body 64 of antenna housing 32.

**[0034]** Referring to FIGS. 9 and 10, a further embodiment of a rearview mirror assembly 110 can include an antenna housing 132 of a plastic material, which may be more rigid than the elastomeric material used in an example of antenna housing 32, described above. In such an example, antenna housing 132 may include a plurality of resiliently flexible mounting tabs 172 extending from body 164 within an interior cavity 166 thereof to one or more engagement ends 173. A corresponding antenna body (which is generally similar to antenna body 54, discussed above, other features not specifically discussed herein also being similar to other features with reference numbers having the same final two digits) may include apertures (similar to apertures 74, discussed above, but repositioned appropriately) to allow mounting tabs 172 to pass therethrough and into a snap-fit arrangement therewith. As shown in FIG. 10, main housing 112 can include corresponding apertures 176 configured to allow mounting tabs 172 to deflect inwardly to pass therethrough and to resiliently snap back into an extended position to engage with main housing 112, thereby retaining communication module 126 with main housing 12. FIGS. 11 and 12 as well as FIGS. 13 and 14, show similar arrangements with respective mounting tabs 172 and 372 extending from respective antenna housings 232 and 332 to engagement ends 273 and 373 that appropriately engage with corresponding main housings 212 and 312 in varying locations and with varying features thereof. As shown in FIGS. 12 and 14, such features may include ribs 284 and 384, which are present within main housing 212 and 312 to give structural support therefor.

**[0035]** As shown in FIGS. 15 and 16 a further embodiment of antenna housing 432 may include a plurality of posts 472 extending from within interior cavity 466 of body 464 of antenna housing 432. Posts 472 may be positionable within corresponding holes (not shown, similar to apertures 76 shown in FIG. 7) with control module 22 appropriately

positioned against exterior surface 414 of main housing 412. A corresponding plurality of spring fasteners 486 can be slid into engagement with posts 472 to engage therewith, thereby coupling communication module 426 with main housing 412. In an example, spring fasteners 486 can be made of a relatively thin, resilient metal material that forms a press fit with posts 472, which may be of plastic or the like. In such an arrangement, spring fasteners 486 may at least partially dig into posts 472 to secure the relative positioning therewith.

**[0036]** It will be understood that any described processes or steps within described processes may be combined with other disclosed processes or steps to form structures within the scope of the present device. The exemplary structures and processes disclosed herein are for illustrative purposes and are not to be construed as limiting.

**[0037]** It is also to be understood that variations and modifications can be made on the aforementioned structures and methods without departing from the concepts of the present device, and further it is to be understood that such concepts are intended to be covered by the following claims unless these claims by their language expressly state otherwise.

**[0038]** The above description is considered that of the illustrated embodiments only. Modifications of the device will occur to those skilled in the art and to those who make or use the device. Therefore, it is understood that the embodiments shown in the drawings and described above is merely for illustrative purposes and not intended to limit the scope of the device, which is defined by the following claims as interpreted according to the principles of patent law, including the Doctrine of Equivalents.

What is claimed is:

1. A rearview mirror assembly, comprising:
  - a housing defining an exterior surface, an interior, and an open side, the exterior surface having a mounting area thereon;
  - a control module coupled within the interior of the housing;
  - a mirror coupled over the open side of the housing;
  - a communication module including:
    - an antenna electrically coupled with the control module; and
    - an antenna housing at least partially enclosing the antenna and coupled within the housing along the mounting area of the exterior surface.
2. The rearview mirror assembly of claim 1, wherein:
  - the exterior surface of the housing defines a recess, the mounting area being positioned within the recess; and
  - the antenna housing is coupled within the mounting area so as to be at least partially within recess.
3. The rearview mirror assembly of claims 1 or 2, wherein:
  - the antenna comprises a substrate defining a major surface and having a thickness; and
  - the antenna housing has a first side overlying the major surface of the antenna and having a body extending from the first side, contacting the mounting area of the housing, and defining a cavity therein within which the antenna body is at least partially enclosed, the cavity having a depth greater than the thickness of the substrate.
4. The rearview mirror assembly of any of the preceding claims, wherein:
  - the housing includes a plurality of apertures extending from the exterior surface to the interior; and
  - the antenna housing includes a plurality of retaining features coupled therewith and engaging with respective ones of the apertures.

5. The rearview mirror of claim 4, wherein:
  - the antenna housing comprises an elastomeric material; and
  - the retaining features are generally cylindrical posts with enlarged portions that engage with the apertures within the interior of the housing with the posts under tension, the retaining features being integral with the antenna housing.
  
6. The rearview mirror of claim 4, wherein:
  - the antenna housing comprises a plastic material; and
  - the retaining features are flexible tabs in a snap fit with a feature of the interior of the housing.
  
7. The rearview mirror of claim 6, wherein the feature of the interior of the housing is one of an edge of the aperture or a structural rib of the housing.
  
8. The rearview mirror of any of claims 1 to 3, wherein:
  - the housing includes a plurality of apertures extending from the exterior surface to the interior;
  - the antenna housing includes a plurality of retaining posts extending through respective ones of the apertures; and
  - the rearview mirror further includes a plurality of spring tabs engaged between respective ones of the plurality of retaining posts and portions of the housing adjacent the apertures.
  
9. A near-field communication module for coupling with a body, comprising:
  - an antenna unit including a substrate defining a perimeter sidewall extending between a first face and a second face, the substrate further defining a plurality of apertures extending between the first face and the second face; and
  - a housing comprising an elastomeric material and including:
    - a body defining an interior cavity, the substrate of the antenna unit being received within the cavity with the body extending over the first face, the perimeter sidewall, and an edge defined between the perimeter sidewall and the second face; and

a plurality of retaining features extending from the cavity of the body and further through respective ones of the plurality of apertures.

10. The near-field communication module of claim 9, wherein:
  - the substrate defines a major surface and has a thickness;
  - the housing has a first side overlying the major surface of the antenna unit and having a body extending from the first side and defining a cavity therein within which the antenna body is at least partially enclosed, the cavity having a depth greater than the thickness of the substrate.
11. The near-field communication module of either of claims 9 or 10, wherein each of the plurality of retaining features has a height that is greater than a depth of the cavity.
12. The near-field communication module of any of claims 9 to 11, wherein:
  - the housing comprises an elastomeric material; and
  - the retaining features are generally cylindrical posts with enlarged portions spaced apart from the body and the substrate, the retaining features being integral with the housing.
13. The near-field communication module of any of claims 9 to 11, wherein:
  - the housing comprises a plastic material; and
  - the retaining features are flexible tabs.
14. The near-field communication module of any of claims 9 to 11, wherein:
  - the retaining features comprise a plurality of retaining posts; and
  - the near-field communication module further includes a plurality of spring tabs engageable with respective ones of the plurality of retaining posts opposite the substrate from the body.
15. The near-field communication module of any of claims 9 to 14, wherein the body further defines a lip extending inwardly from the edge to at least partially retain the substrate within the cavity.

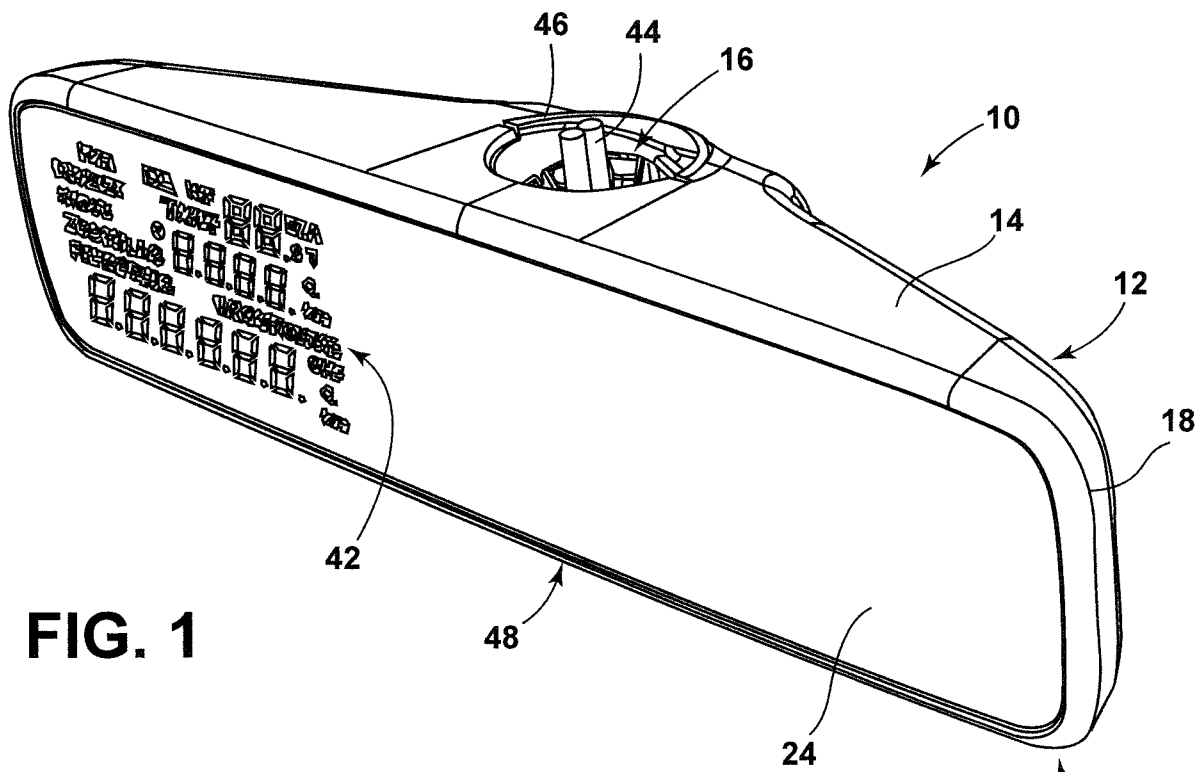


FIG. 1

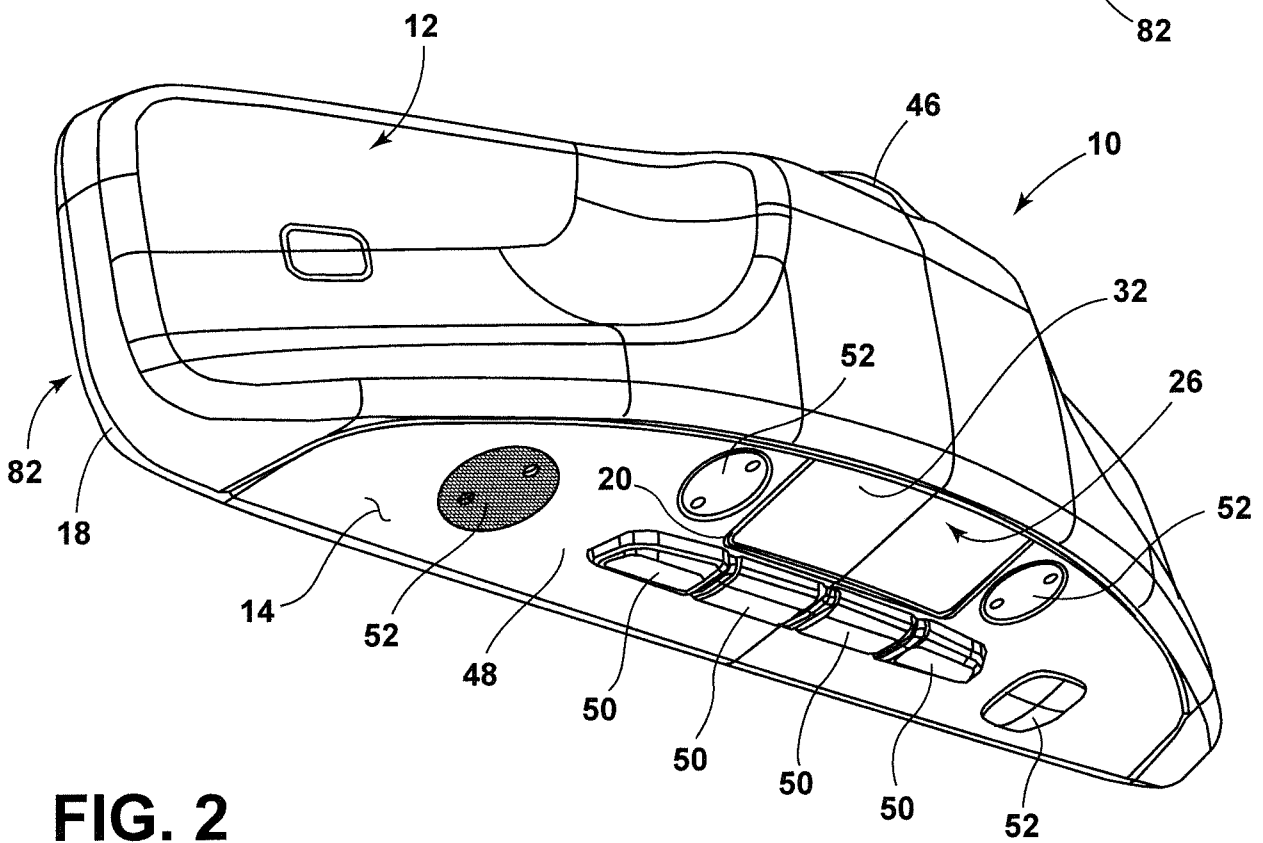


FIG. 2

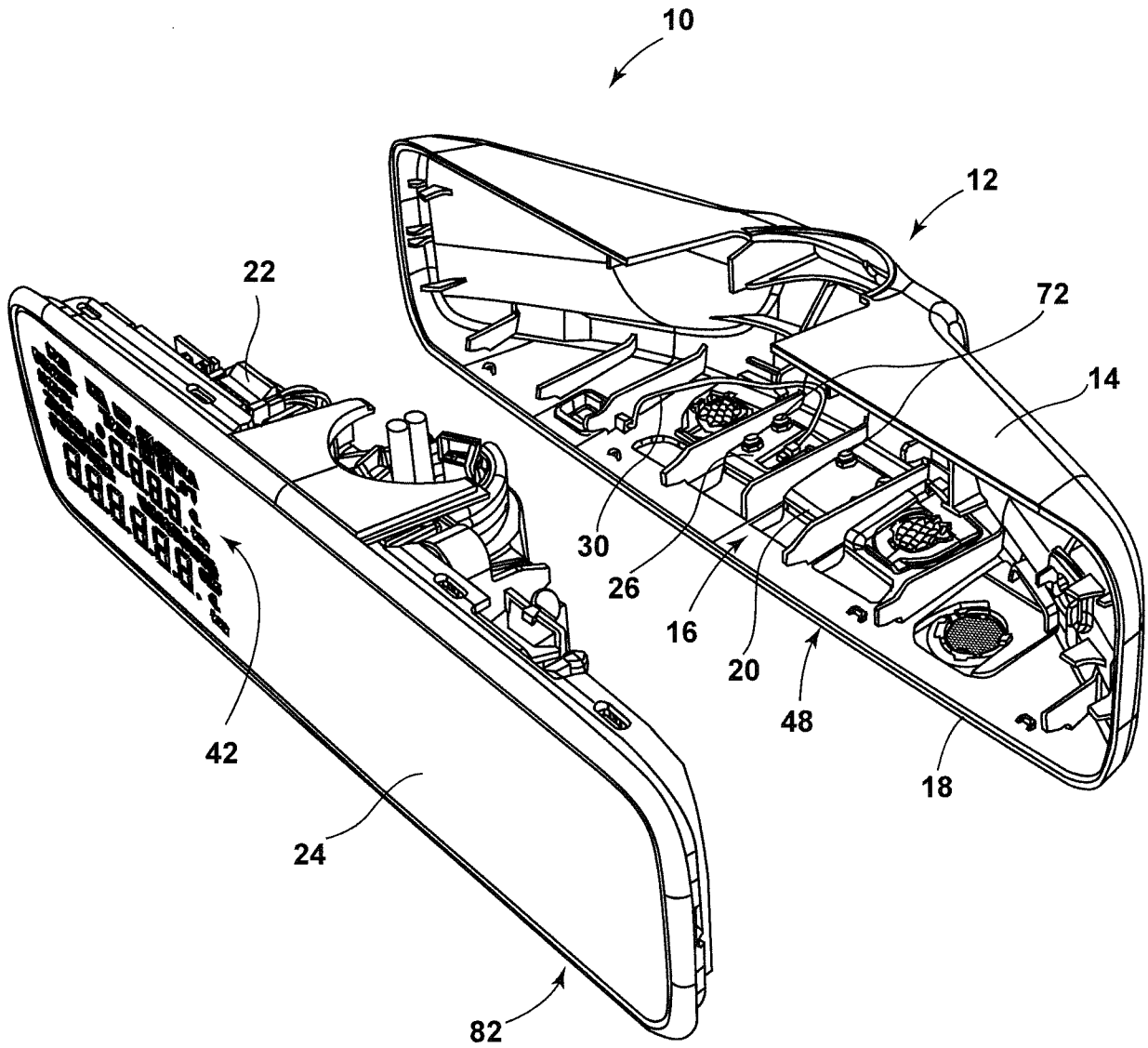
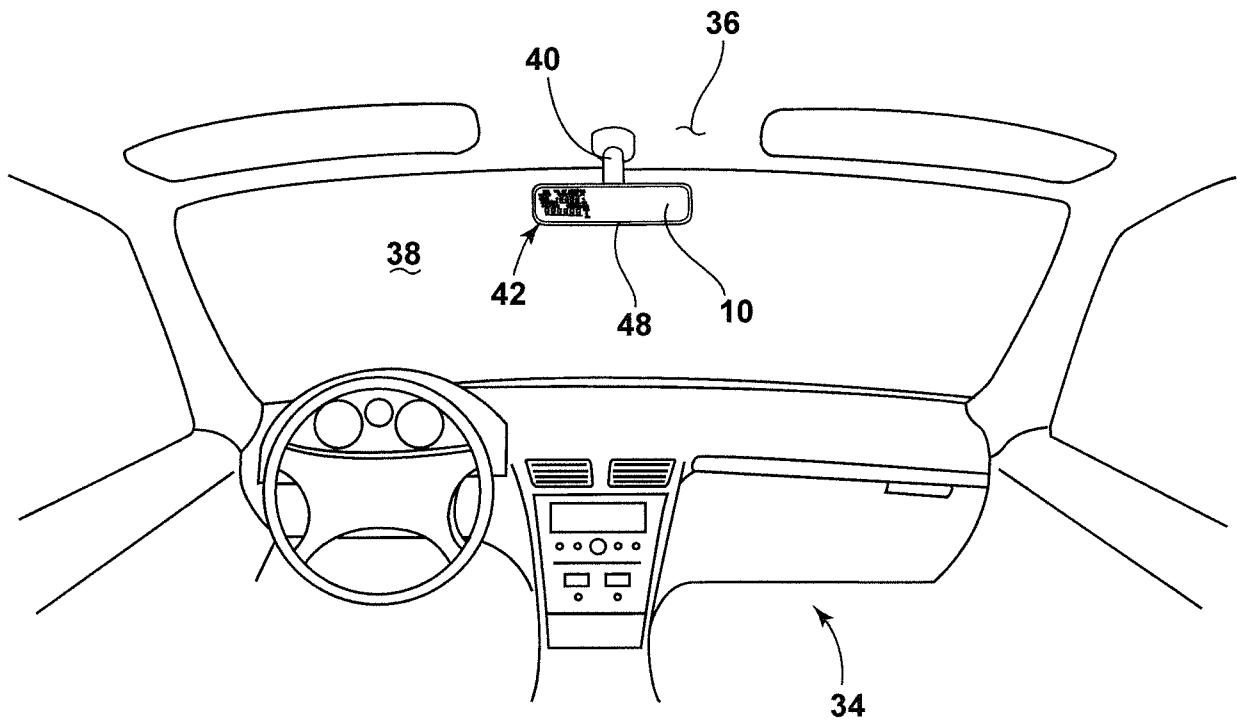
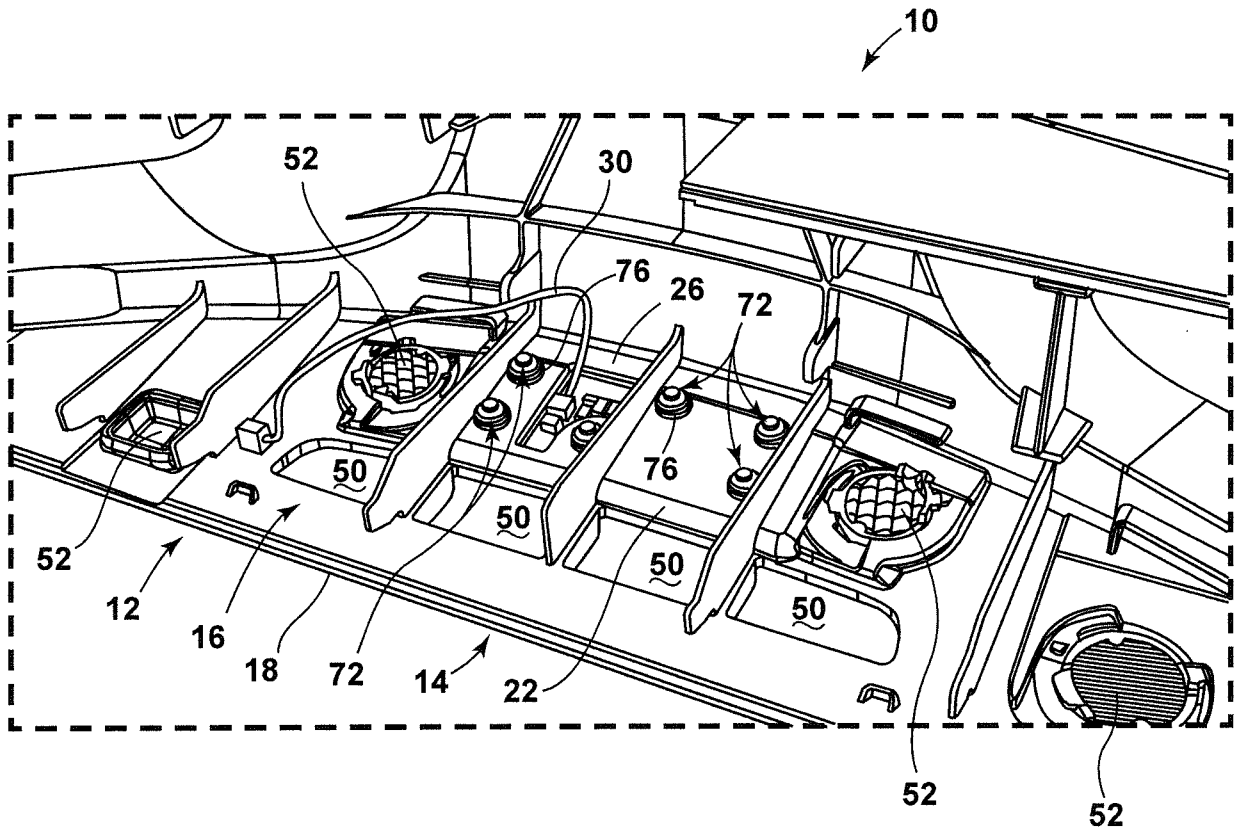


FIG. 3





**FIG. 4**



**FIG. 5**

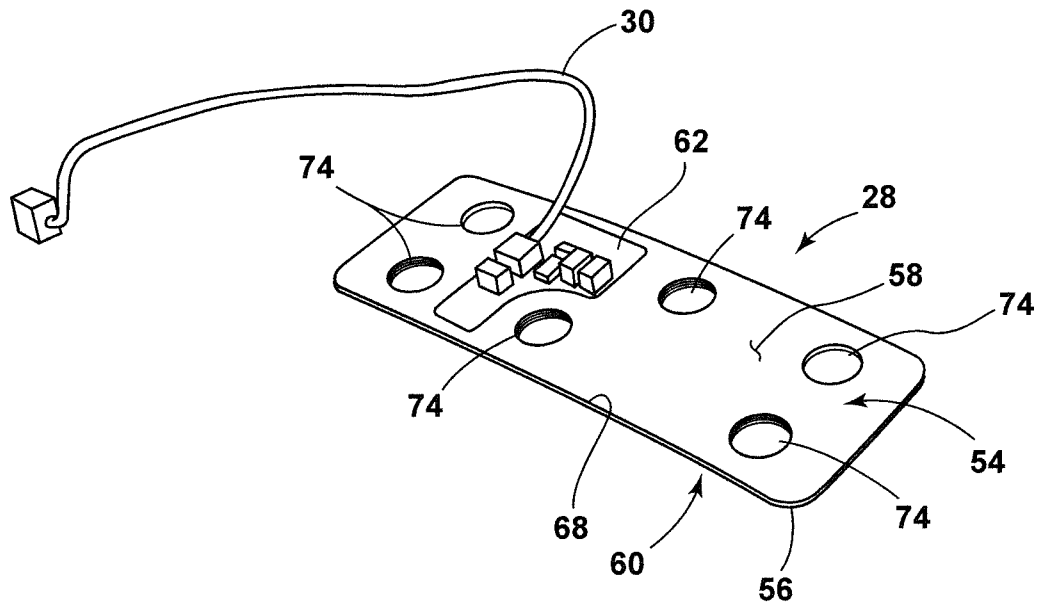


FIG. 6

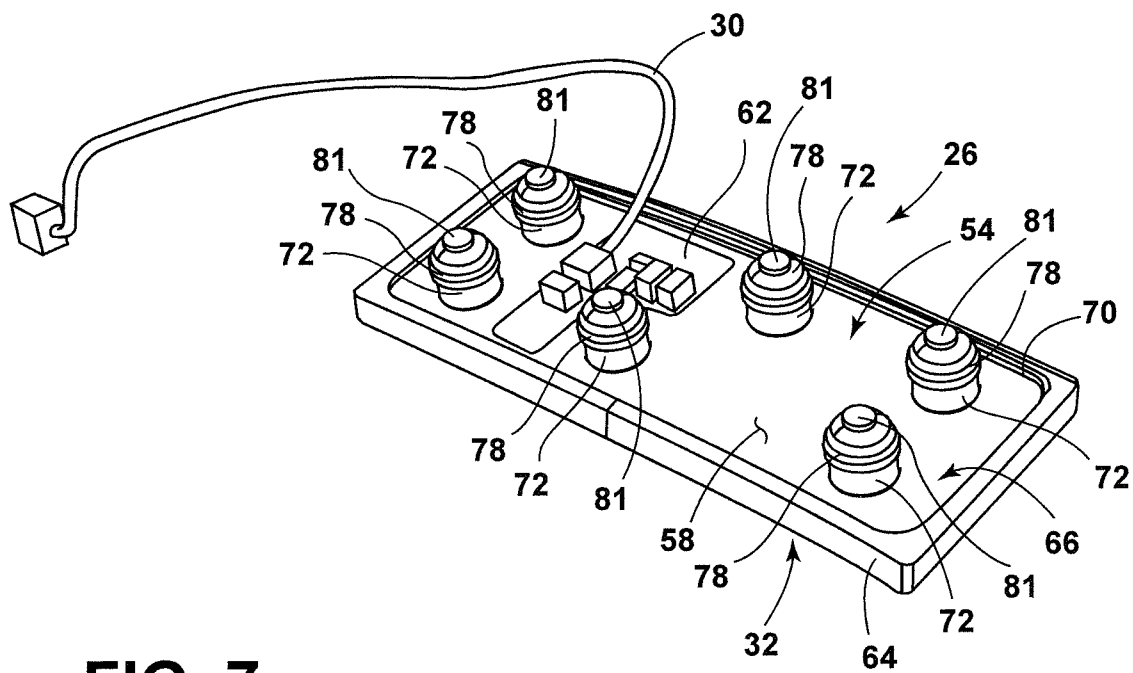
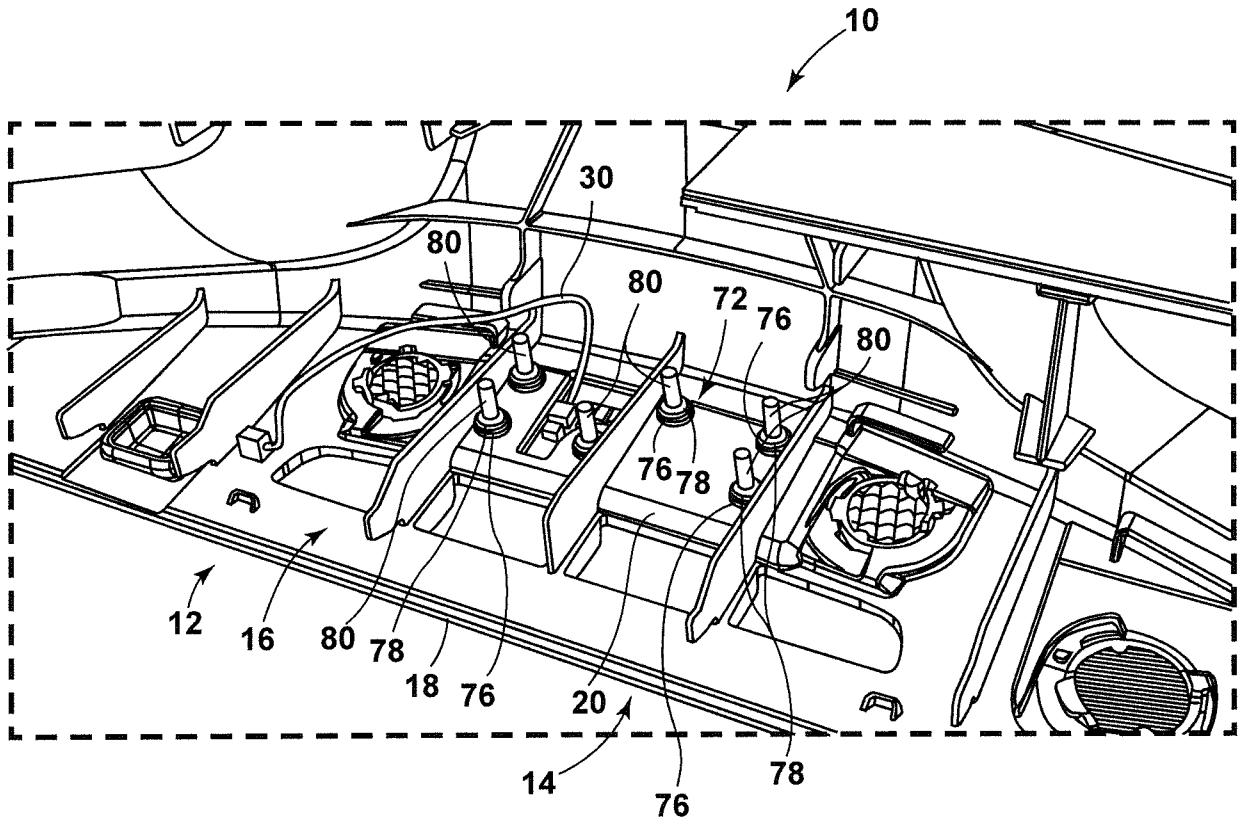
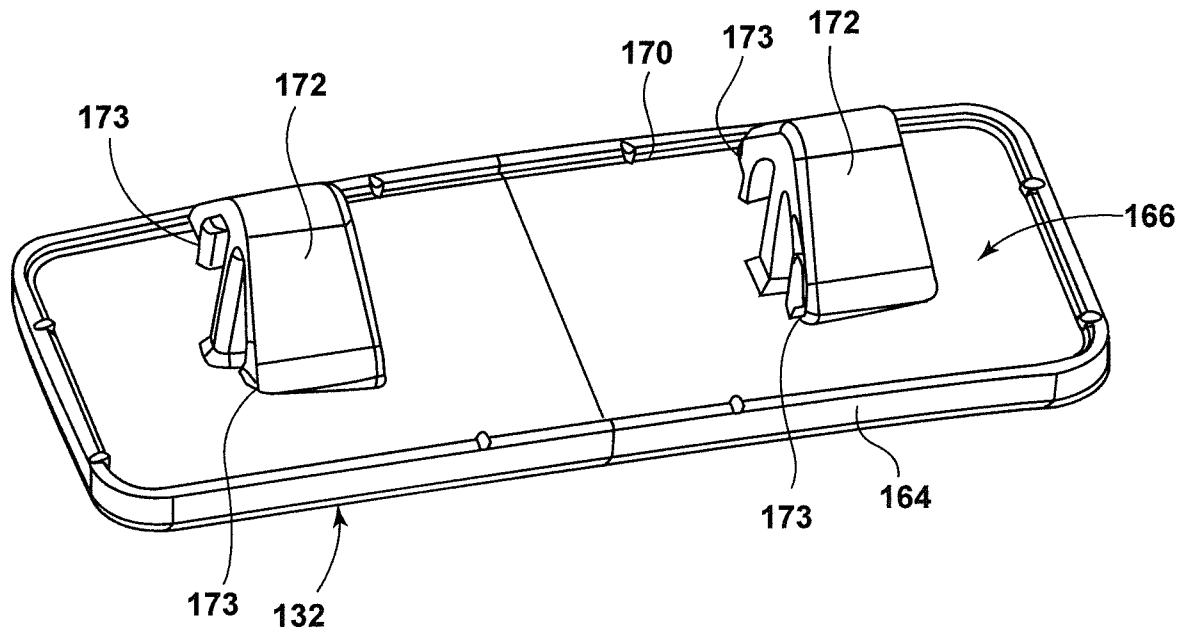


FIG. 7

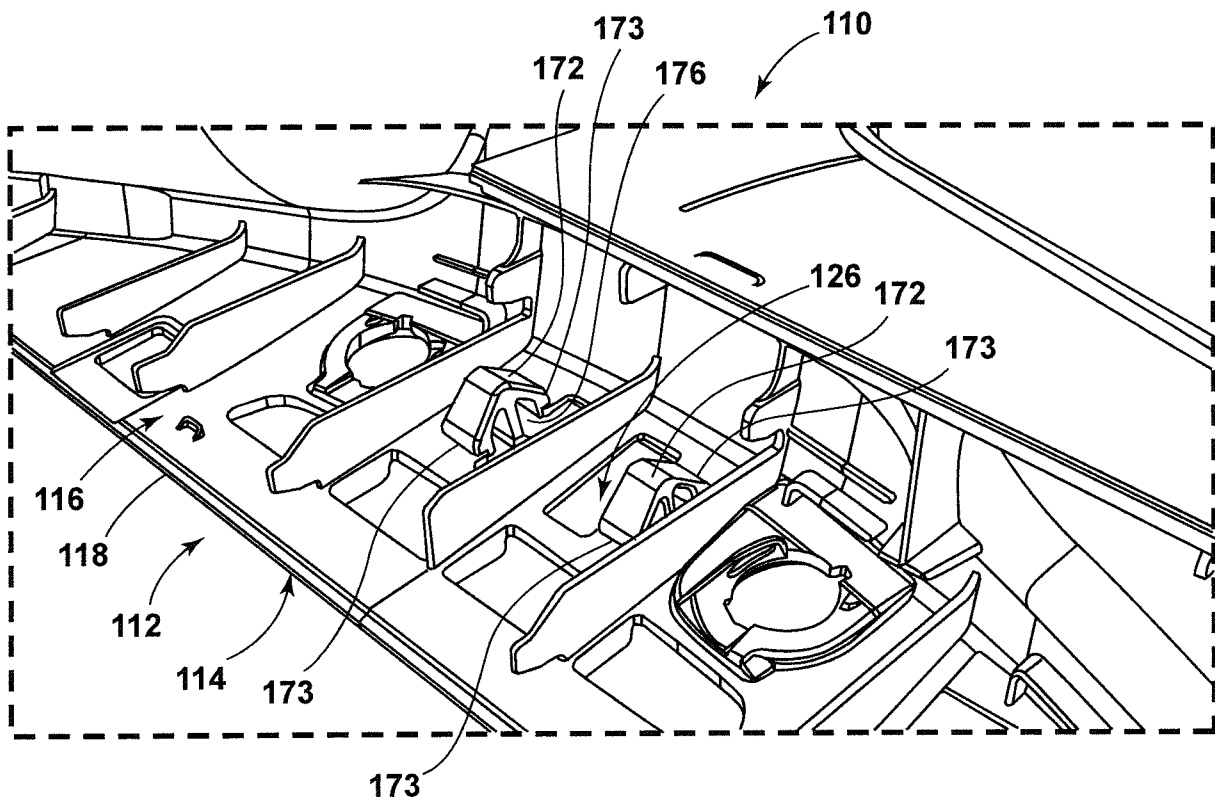


**FIG. 8**

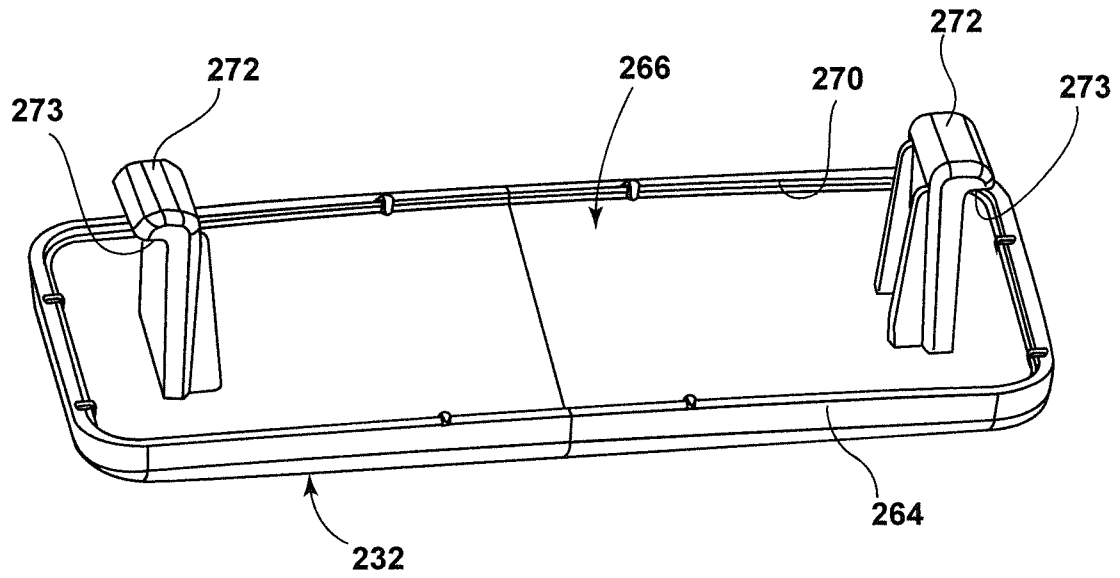
7/10



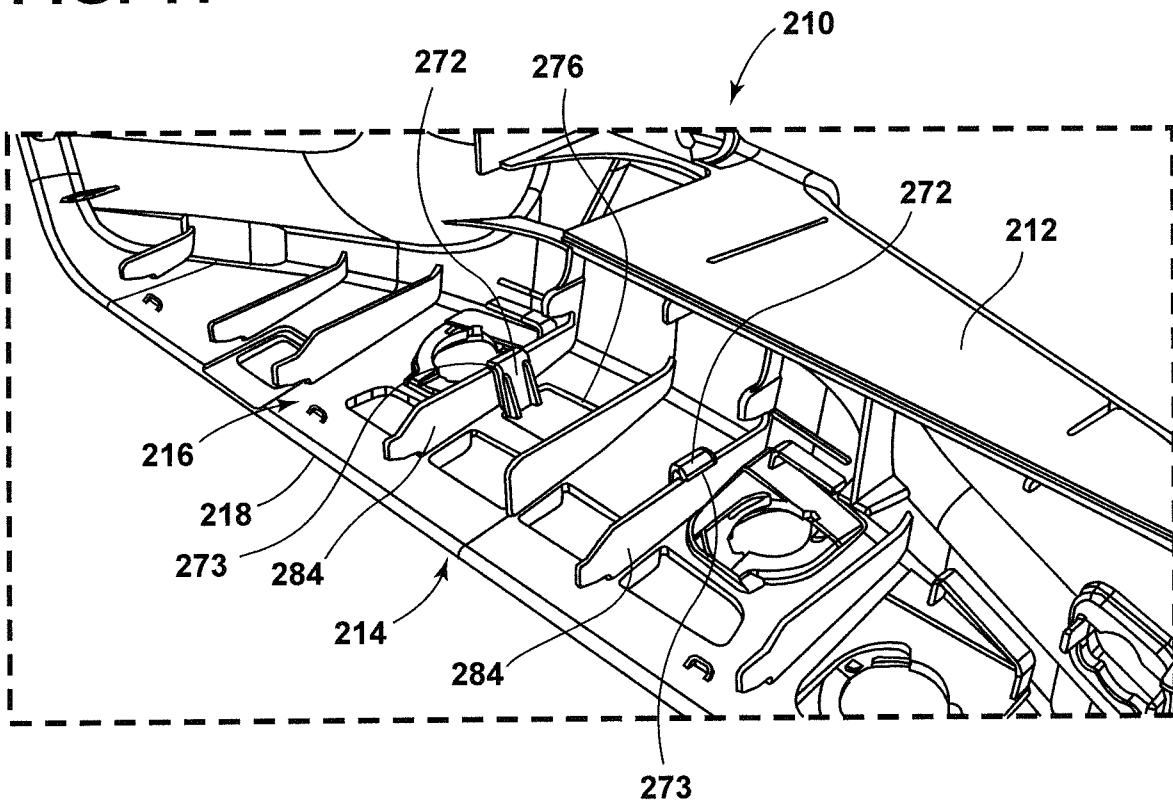
**FIG. 9**



**FIG. 10**

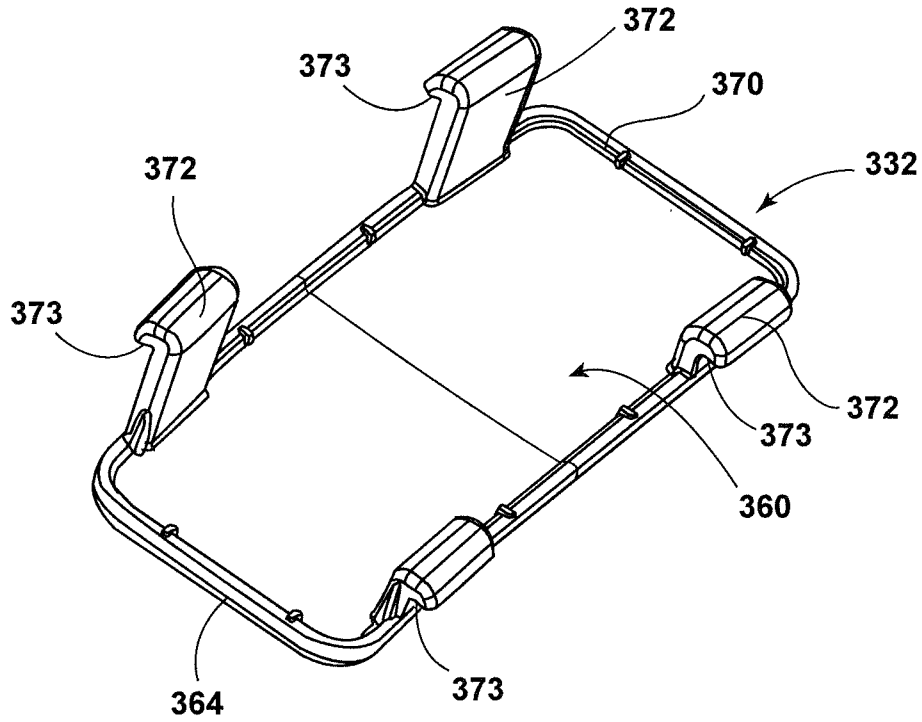


**FIG. 11**

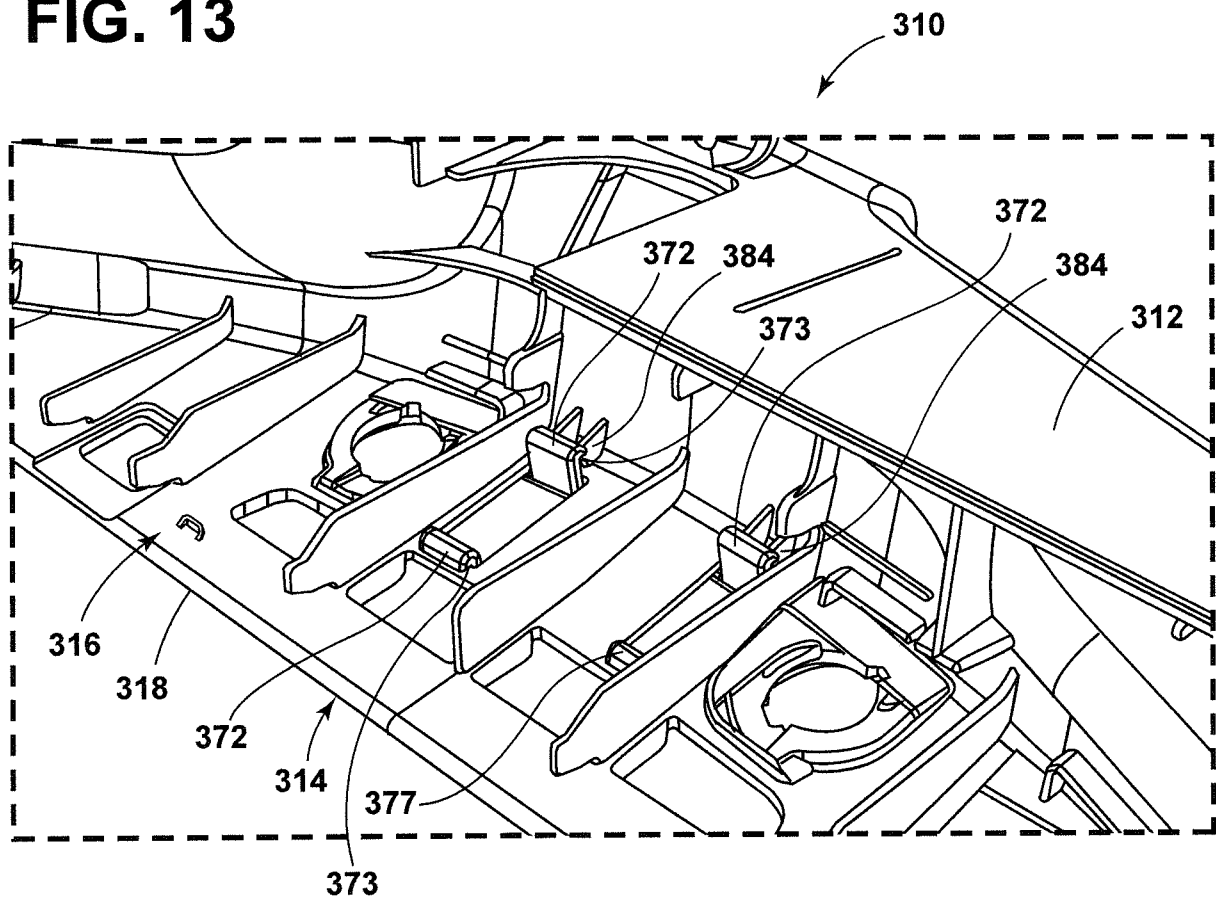


**FIG. 12**

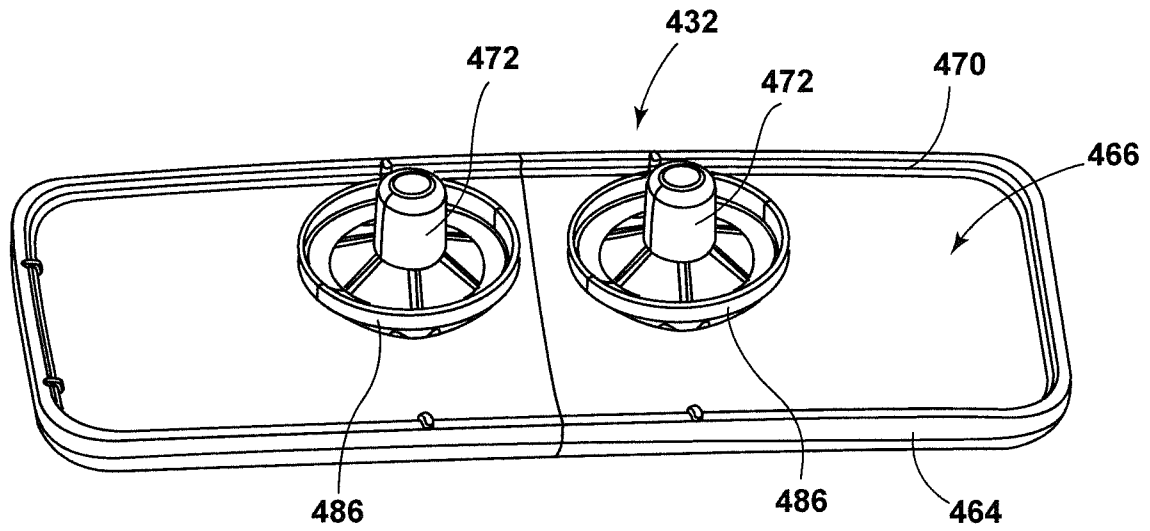
9/10



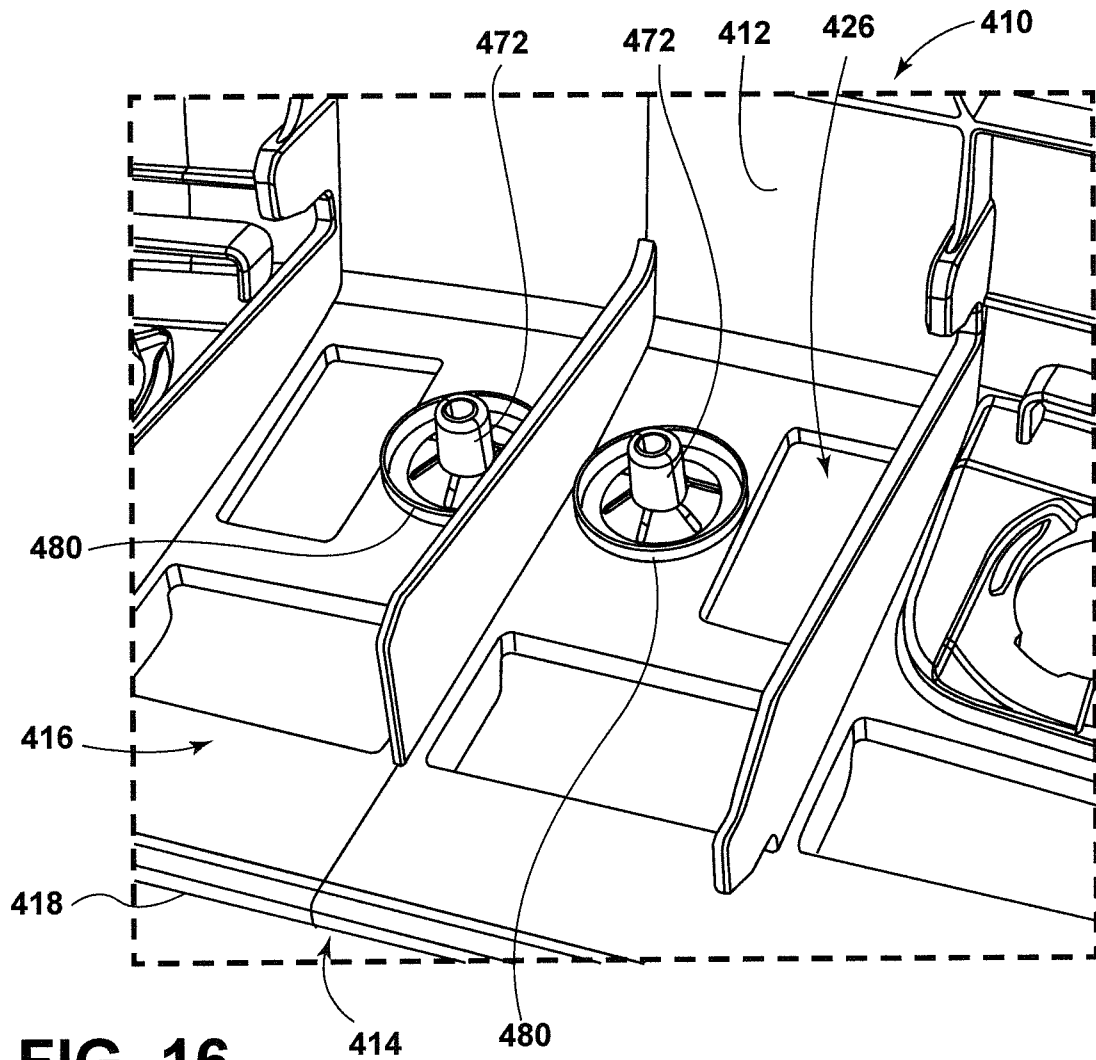
**FIG. 13**



**FIG. 14**



**FIG. 15**



**FIG. 16**



## INTERNATIONAL SEARCH REPORT

International application No.

PCT/US 2015/061306

A. CLASSIFICATION OF SUBJECT MATTER		
<i>B60R 1/04 (2006.01)</i> <i>B60R 1/12 (2006.01)</i> <i>H01Q 1/32 (2006.01)</i>		
According to International Patent Classification (IPC) or to both national classification and IPC		
B. FIELDS SEARCHED		
Minimum documentation searched (classification system followed by classification symbols)		
B60R 1/00-1/12, 21/00-21/08, H01Q 1/00-1/32, H04M 1/00		
Documentation searched other than minimum documentation to the extent that such documents are included in the fields searched		
Electronic data base consulted during the international search (name of data base and, where practicable, search terms used)		
PatSearch (RUPTO internal), USPTO, PAJ, Esp@cenet, DWPI, EAPATIS, PATENTSCOPE		
C. DOCUMENTS CONSIDERED TO BE RELEVANT		
Category*	Citation of document, with indication, where appropriate, of the relevant passages	Relevant to claim No.
X	US 7327226 B2 (GENTEX CORPORATION) 05.02.2008, abstract, col. 15, line 30-col. 17, line 17, line 49, fig. 1-18	1-3
Y		9-11
Y	EP 0860325 B1 (DONNELLY CORPORATION) 27.11.2002, abstract, [0012]-[0015], fig. 1-4	9-11
A	EP 2340966 B1 (SMR PATENTS S.A.R.L.) 25.12.2013	1-3, 9-11
<input type="checkbox"/> Further documents are listed in the continuation of Box C. <input type="checkbox"/> See patent family annex.		
*	Special categories of cited documents:	“T” later document published after the international filing date or priority date and not in conflict with the application but cited to understand the principle or theory underlying the invention
“A”	document defining the general state of the art which is not considered to be of particular relevance	“X” document of particular relevance; the claimed invention cannot be considered novel or cannot be considered to involve an inventive step when the document is taken alone
“E”	earlier document but published on or after the international filing date	“Y” document of particular relevance; the claimed invention cannot be considered to involve an inventive step when the document is combined with one or more other such documents, such combination being obvious to a person skilled in the art
“L”	document which may throw doubts on priority claim(s) or which is cited to establish the publication date of another citation or other special reason (as specified)	“&” document member of the same patent family
“O”	document referring to an oral disclosure, use, exhibition or other means	
“P”	document published prior to the international filing date but later than the priority date claimed	
Date of the actual completion of the international search		Date of mailing of the international search report
19 January 2016 (19.01.2016)		11 February 2016 (11.02.2016)
Name and mailing address of the ISA/RU: Federal Institute of Industrial Property, Berezhkovskaya nab., 30-1, Moscow, G-59, GSP-3, Russia, 125993 Facsimile No: (8-495) 531-63-18, (8-499) 243-33-37		Authorized officer  N. Bedretdinov  Telephone No. 499-240-25-91

**Box No. II Observations where certain claims were found unsearchable (Continuation of item 2 of first sheet)**

This international search report has not been established in respect of certain claims under Article 17(2)(a) for the following reasons:

1.  Claims Nos.:  
because they relate to subject matter not required to be searched by this Authority, namely:
  
2.  Claims Nos.:  
because they relate to parts of the international application that do not comply with the prescribed requirements to such an extent that no meaningful international search can be carried out, specifically:
  
3.  Claims Nos.: 4-8, 12-15  
because they are dependent claims and are not drafted in accordance with the second and third sentences of Rule 6.4(a).

**Box No. III Observations where unity of invention is lacking (Continuation of item 3 of first sheet)**

This International Searching Authority found multiple inventions in this international application, as follows:

1.  As all required additional search fees were timely paid by the applicant, this international search report covers all searchable claims.
2.  As all searchable claims could be searched without effort justifying additional fees, this Authority did not invite payment of additional fees.
3.  As only some of the required additional search fees were timely paid by the applicant, this international search report covers only those claims for which fees were paid, specifically claims Nos.:
4.  No required additional search fees were timely paid by the applicant. Consequently, this international search report is restricted to the invention first mentioned in the claims; it is covered by claims Nos.:

**Remark on Protest**

- The additional search fees were accompanied by the applicant's protest and, where applicable, the payment of a protest fee.
- The additional search fees were accompanied by the applicant's protest but the applicable protest fee was not paid within the time limit specified in the invitation.
- No protest accompanied the payment of additional search fees.